



INSTALLATION GUIDE



Lakewood Waterfall Single Lever

Bathroom Faucet

PB-L02

RECOMMENDED TOOLS AND MATERIALS

- ◆ Plumbers Putty
- ◆ Adjustable Wrench
- ◆ Tape Measure
- ◆ Basin Wrench
- ◆ Phillips Screwdriver
- ◆ Pencil
- ◆ Masking Tape

BEFORE YOU BEGIN

There are a variety of things to do before installing any new plumbing system into your home or residence. Before you begin work make sure you:

- ◆ Shut off the main water supply
- ◆ Observed any local plumbing codes
- ◆ If possible, install the faucet before the sink
- ◆ Inspect tubing for damage - Replace as necessary

Pacific Bay reserves the right to make any revisions in the design of faucets without notice.

MAINTENANCE AND CLEANING

Cleaning Tips: The finish on your faucet is designed to retain its beautiful sheen for years. To maintain the original look of the finish, a little care and caution should be used. We recommend the use of mild soap and water to clean the faucet. **THE USE OF ABRASIVE CLEANERS MAY SCRATCH THE FINISH OR CAUSE OTHER DAMAGE.**

INSTALLATION OF THE FAUCET

Before starting turn off both the hot and cold water supply lines and remove the old faucet. Clean around all areas of attachment before placing new faucet on sink to help prevent corrosion after installation.

Parts List

Screw



Lock-nut



Washer



1 Secure Faucet

Remove both the lock-nut and washer provided. Place faucet on sink by feeding hoses down through the center hole in sink. From below secure faucet by re-attaching lock-nut and washer and screwing down until tight. Make sure you tighten lock nut before screws.

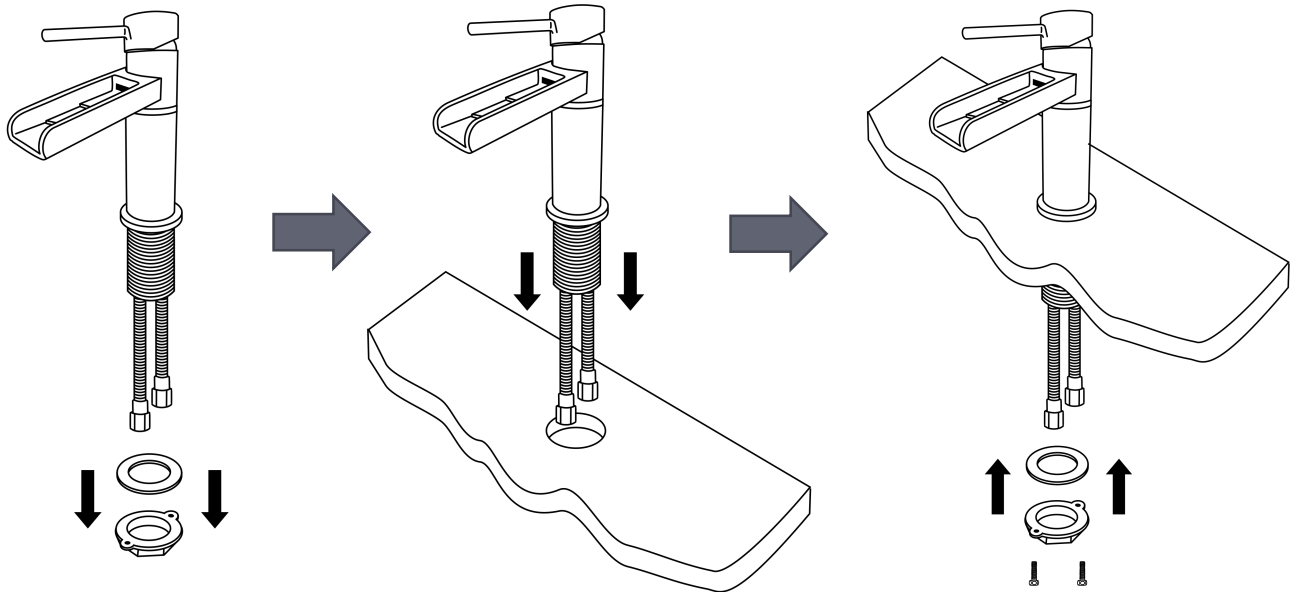

2 Connect Supplies & Flush Lines

Securely attach marked supply lines with corresponding hot and cold tubes from faucet. Tighten all connections with wrench to ensure that no leaking occurs. With all pipe attachments plumbers tape can be utilized to help reduce the risk of leaking. Once attached Turn on the hot and cold water supply lines. Turn the faucet handle to the cold side and lift the handle to the “on” position. Run the water for one minute to remove any potential debris. Rotate handle to the warm side and run for a minute. During this process watch for any water leaks in the pipes.

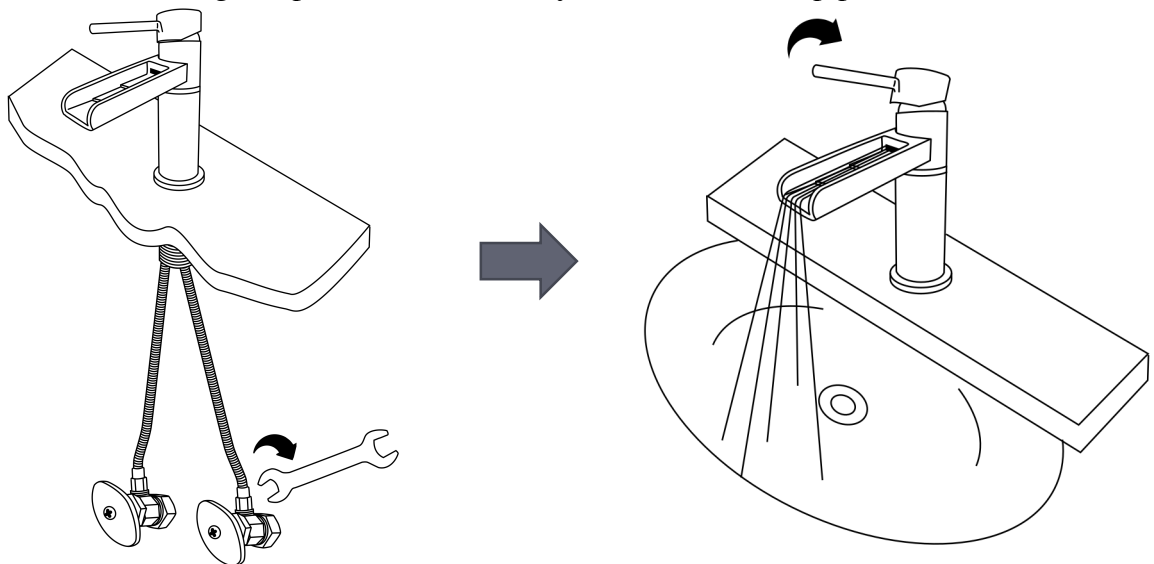



Limited Lifetime Warranty

Pacific Bay products have been manufactured under the highest standards of quality and workmanship. Pacific Bay warrants to the original purchaser for as long as the original purchaser owns their home that this faucet will be leak- and drip-free during normal use and that all parts and finishes of this faucet will be free from defects in material and manufacturing workmanship. If the faucet is used commercially Pacific Bay warrants the faucet to be free from defects in material and workmanship for (5) years from the date the faucet was purchased. Plated metal and plated plastic finishes are warranted for (1) year.

If the faucet should develop a leak or drip during the warranty period, Pacific Bay will, free of charge, provide the parts necessary to put the faucet back into good working condition by you. They may also replace any part or finish that proves defective in material and manufacturing workmanship, under normal installation, use and service free of charge. Proof of purchase (original sales receipt) from the original purchaser must accompany all warranty claims. Defects or damages caused by the use of other products or parts is not covered by this warranty. If repair or replacement is not practical, Pacific Bay may elect to refund the purchase price in exchange for the return of the product.

This warranty covers replacement of all defective parts and finishes. However, damage due to product abuse, product misuse, installation error, or the use of cleaners containing alcohol, abrasives, or other solvents, whether performed by a contractor, service company, or yourself will void this warranty. Pacific Bay will not be responsible for labor charges and/or damages incurred in installation, repair or replacement, nor any indirect, incidental or consequential damages, losses, injury costs of any nature relating to this faucet. Except as provided by law, this warranty is in lieu of and excludes all other warranties, conditions and guarantees, whether expressed or implied, statutory or otherwise, including without restriction those of merchantability or of fitness for use.

Pacific Bay will advise you on how to proceed in making warranty claims. To begin a warranty claim, write to Pacific Bay explaining the defect and include proof of purchase and your name, address and telephone number. Email is info@pacificbayfaucets.com.