

ASSEMBLY INSTRUCTIONS

FABRIC 150CM 4 DRAWER BED

Approximate Assembly Time



People Required to Assemble



Tools Required

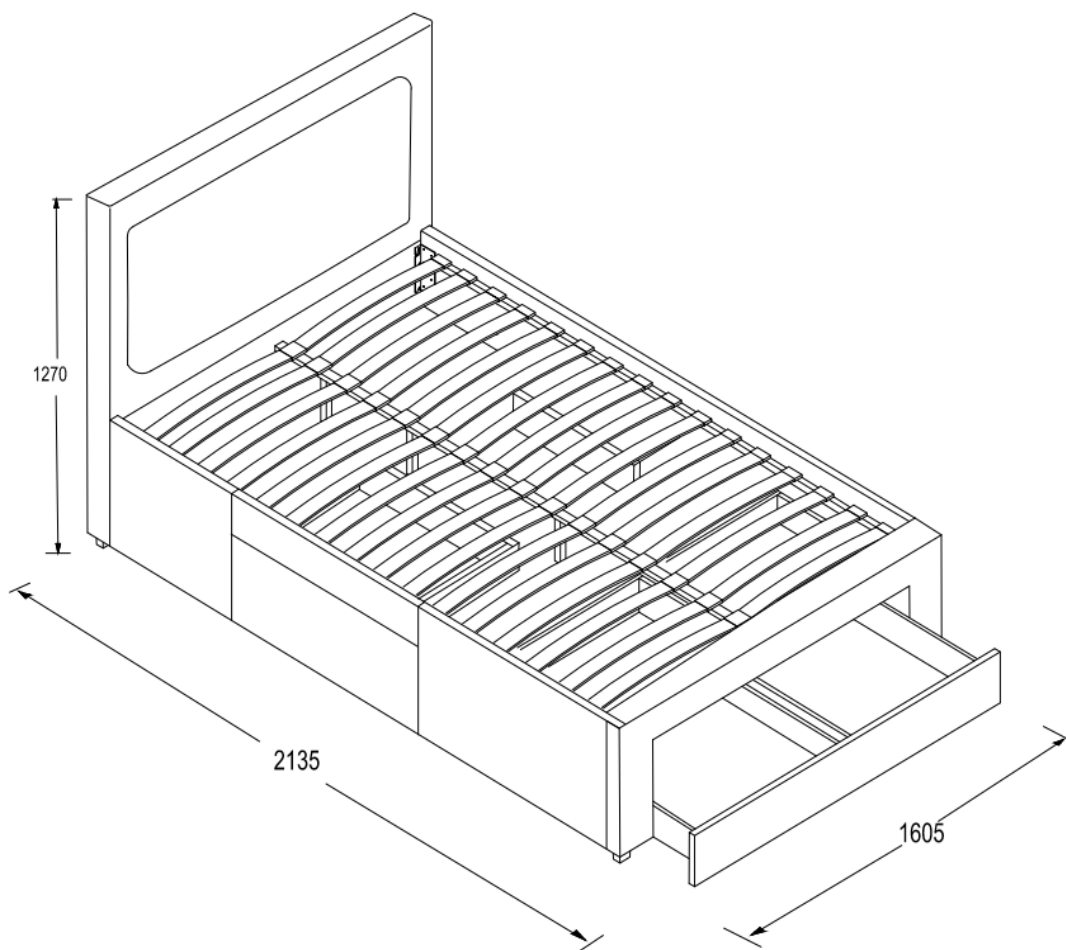

Before you Start

Please carefully unpack and lay out all of the component parts to ensure nothing is missing and to check each component for any obvious damage.

Should you identify any concerns at this stage please contact the retailer from whom this product was purchased. Please quote your order number, details of your issue, the product code, and the batch number from the cartons which will help to resolve your issue as quickly as possible.

Version Number - 1.0

Product Code: MAY002

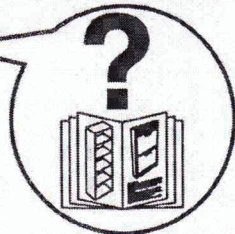
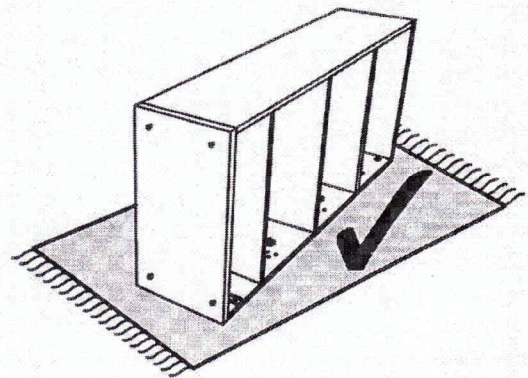
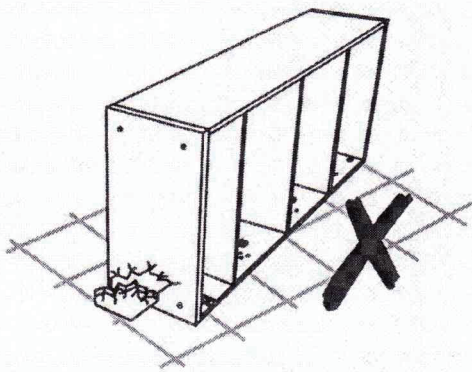
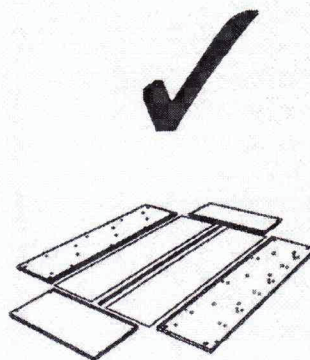
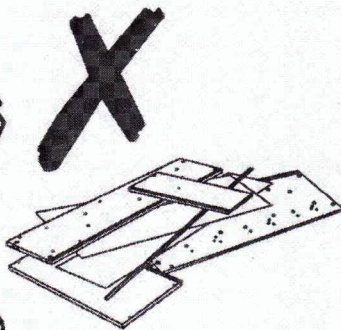
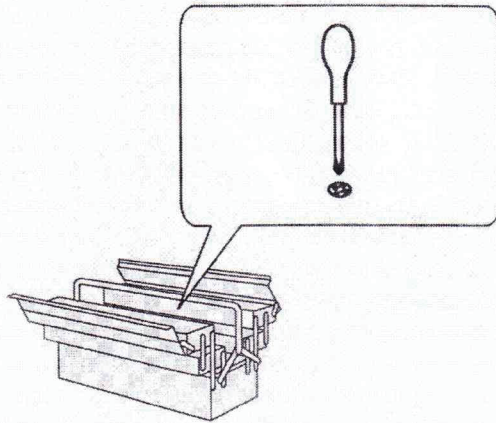
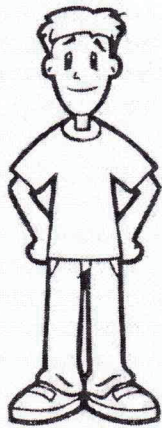

Contact Retailer

Hardware

1

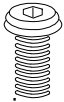

Already inserted into
Head & Foot Ends
Bolt M8 x 30mm
- 12 X

2

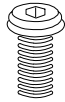

Bolt M8 x 20mm
- 2 X

3

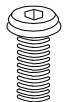

Bolt M6 x 30mm
- 8 X

4

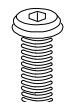

Bolt M6 x 45mm
- 8 X

5

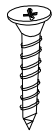

Screw M4 x 20mm
- 64 X

6

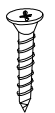

Screw M4 x 16mm
- 1 X

7



Screw M4 x 50mm
- 8 X

8

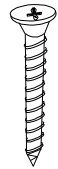

Screw M5 x 50mm
- 48 X

9



Screw M5 x 70mm
- 3 X

10



Nut - 48 X

11



Allen Key (M5)
- 1 X

12



Allen Key (M4)
- 1 X

13



Slat Cap - 32 X

14



Middle Cap For
Sprung Base - 16 X

15



Non-Slip Pads
- 4 X

16



Non-Slip Pads
30 x 60mm - 4 X

Parts

A

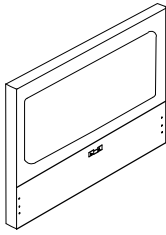

Headboard - 1 X

B

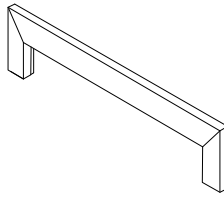

Footboard - 1 X

C

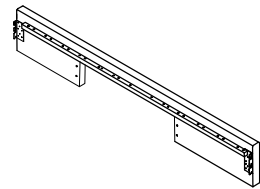

Side Rail - 2 X

D

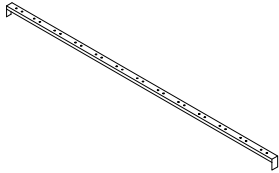

Centre Rail - 1 X

E



Centre Support Legs
- 3 X

F



Support Legs I. 4 X

G



Wooden Foot - 4 X

H

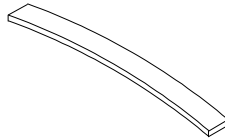

Sprung Slat - 32 X

I

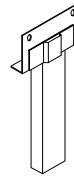

Support Legs II. 1 X

J

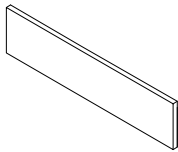

Drawer Front Panel SI I
- 2 X

K

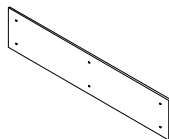

Drawer Front SI I-2 X

L

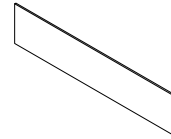

Drawer Back Panel SI
I - 2 X

M

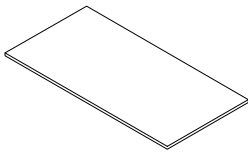

Drawer Bottom Panel SI
I - 2 X

N

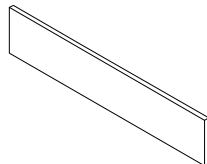

Drawer Front Panel FB II
- 1 X

O

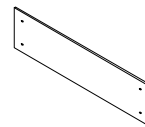

Drawer Front FB II
2 X

P

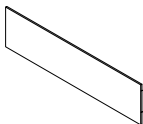

Drawer Back Panel FB
II - 2 X

Q

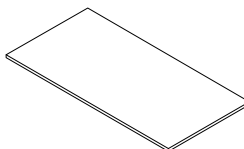

Drawer Bottom Panel FB
II - 2 X

R

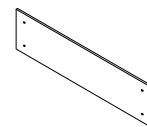

Drawer Side Panel
- 8 X

S

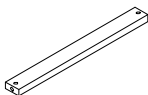

Bottom Support Rail
- 8 X

T



Wheel - 16 X

Safety Advice

Please take the time to carefully read through the whole of these instructions before you commence.

Keep these instructions for future reference.

Unpack, inspect and check off all of the contents.

Please dispose of all packaging safely.

Small component parts could choke a child if swallowed.

We strongly recommend that you keep children well away from the work area.

It would be sensible to lay a sheet or blanket on the floor where you intend to work to avoid scratching this product and to protect your floor.

This product is heavy. Take extreme care when lifting to avoid personal injury or damage to the product.

Assemble the product as close to its intended final position in the room as possible.

HANDY HINT: If you keep the hardware in a bowl during assembly you will be less likely to lose them

STEP 1

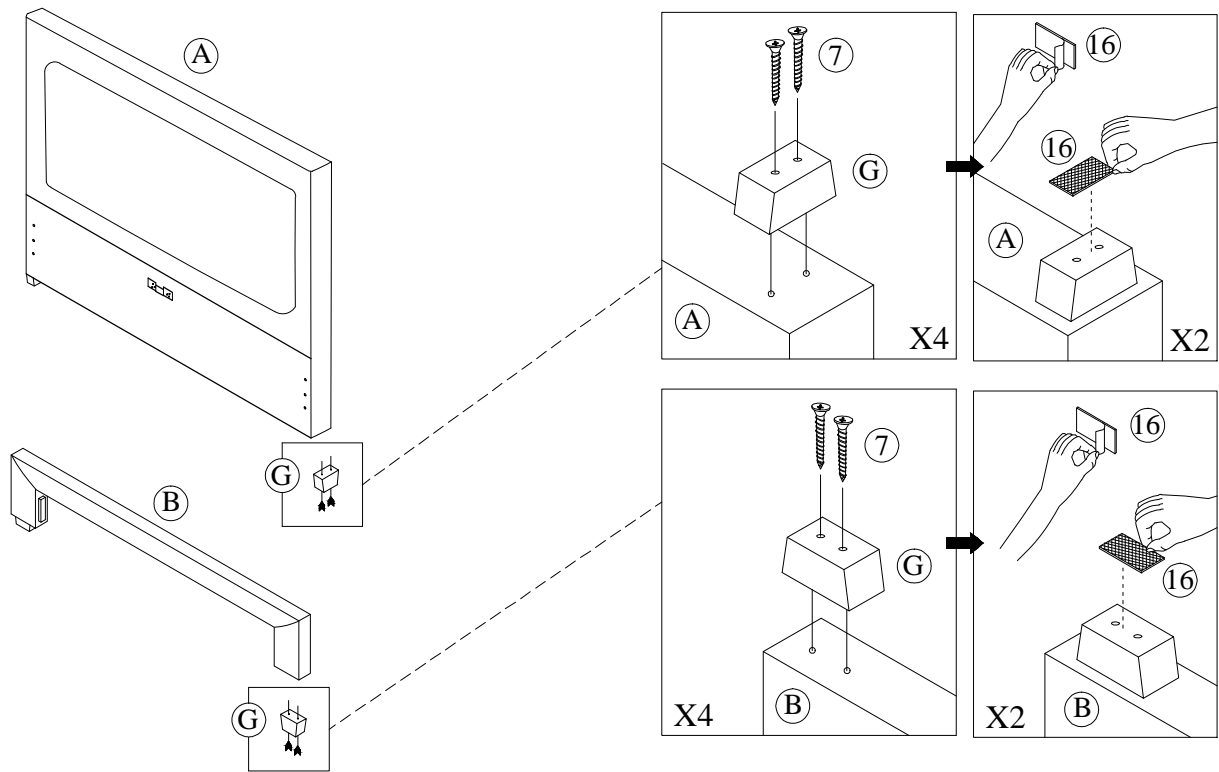

STEP 2

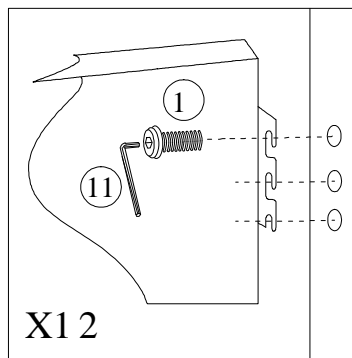

Please note that the Bolt (1) x 12 are prefixed into parts A & B

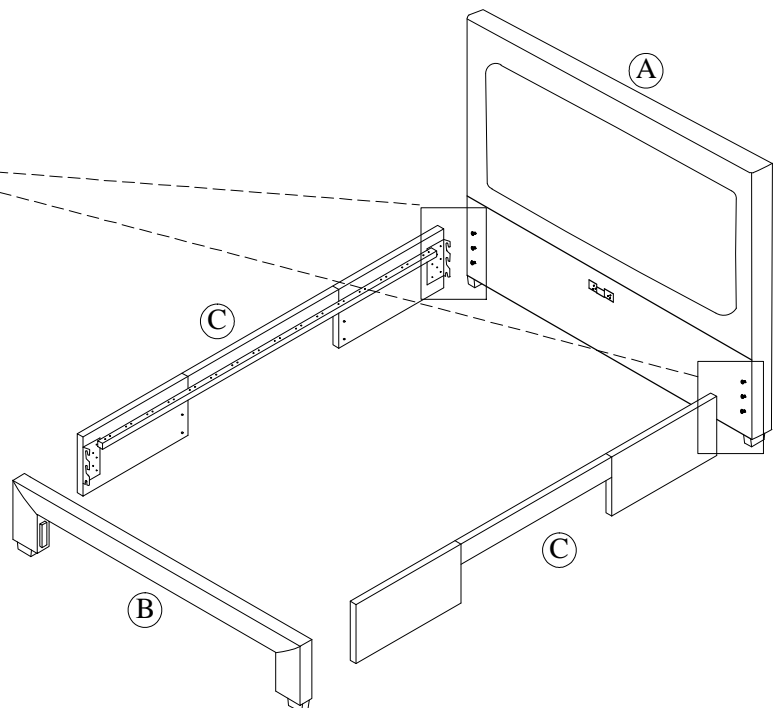

STEP 3

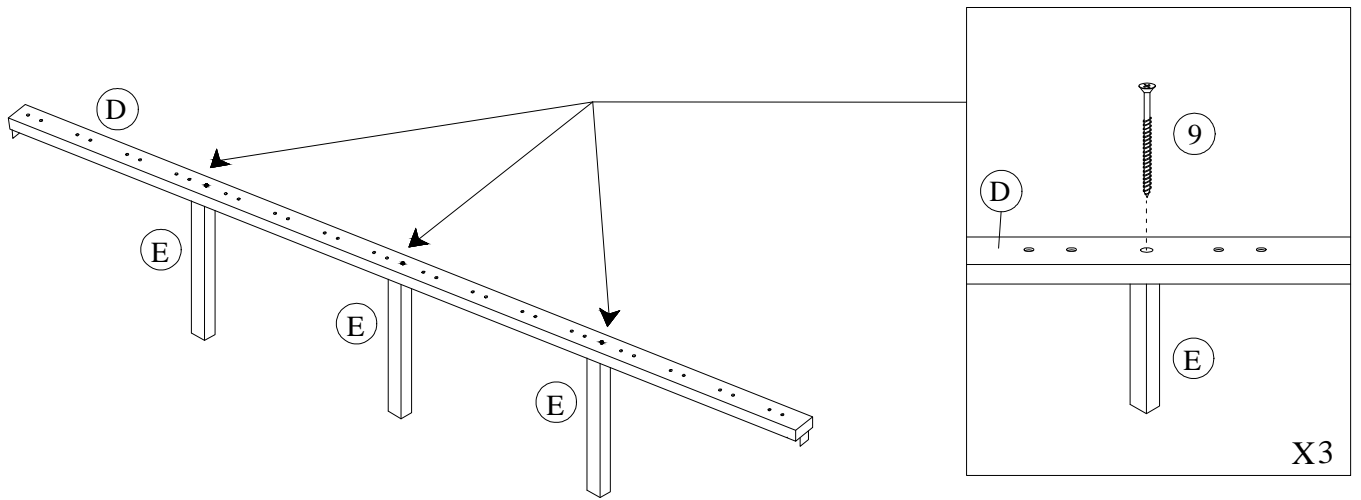

STEP 4

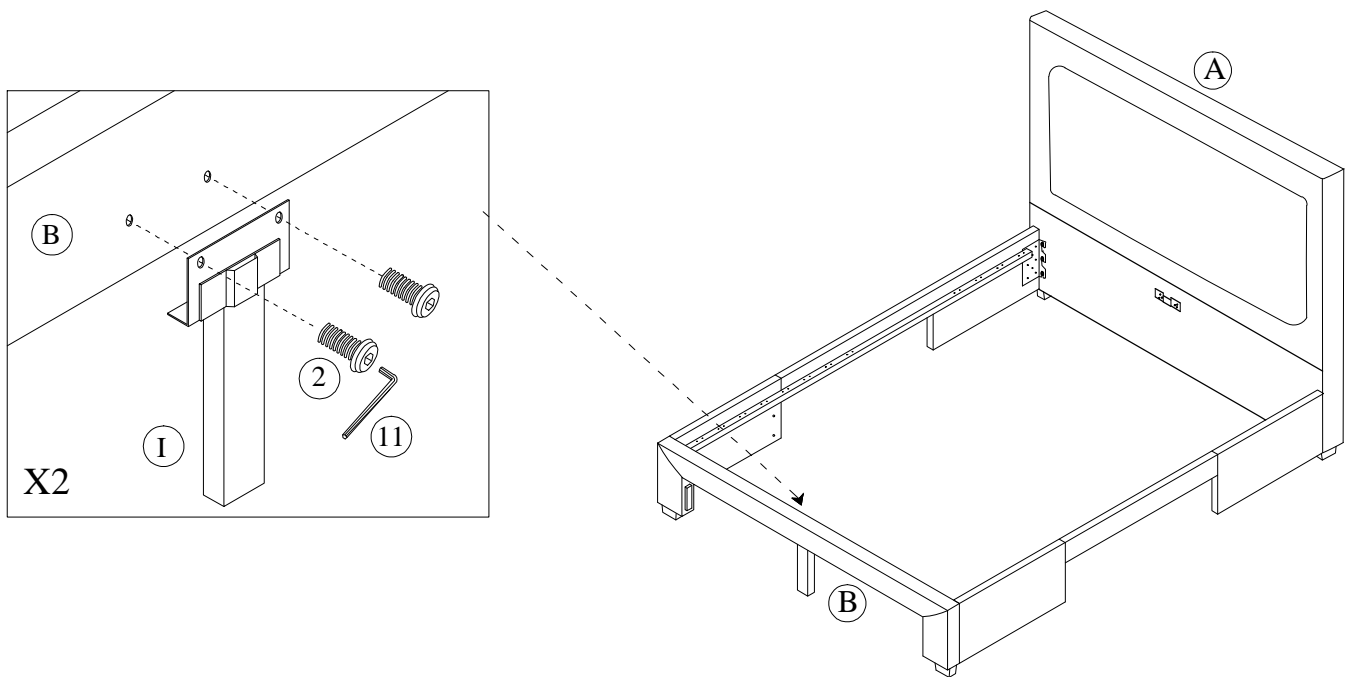

STEP 5

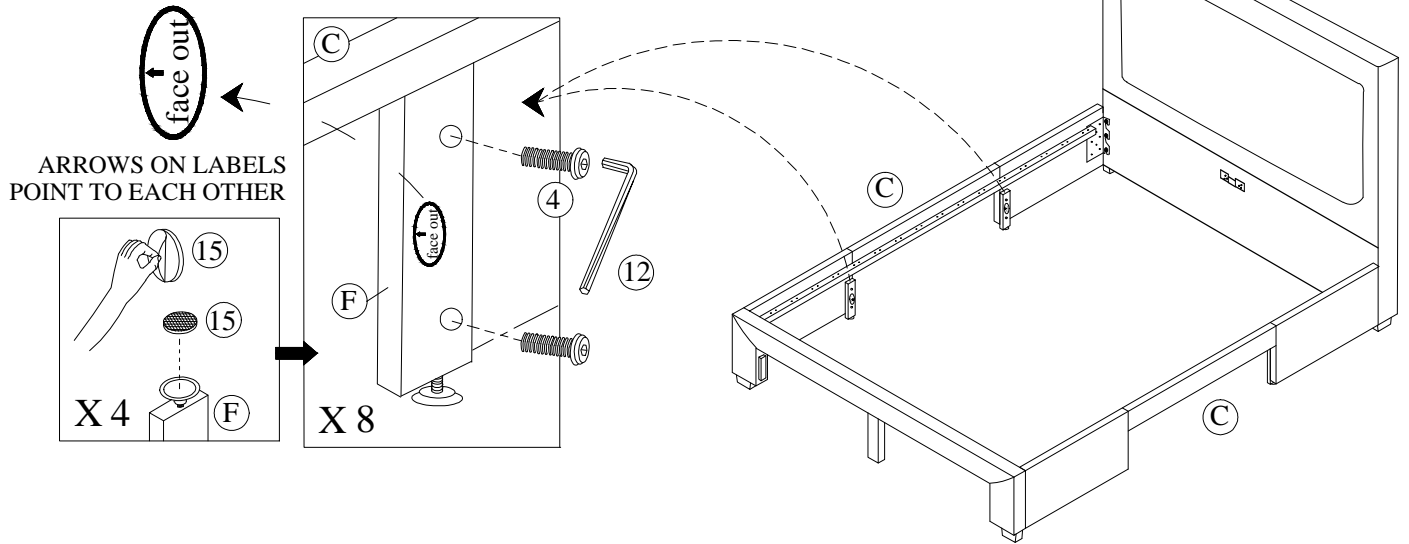

STEP 6

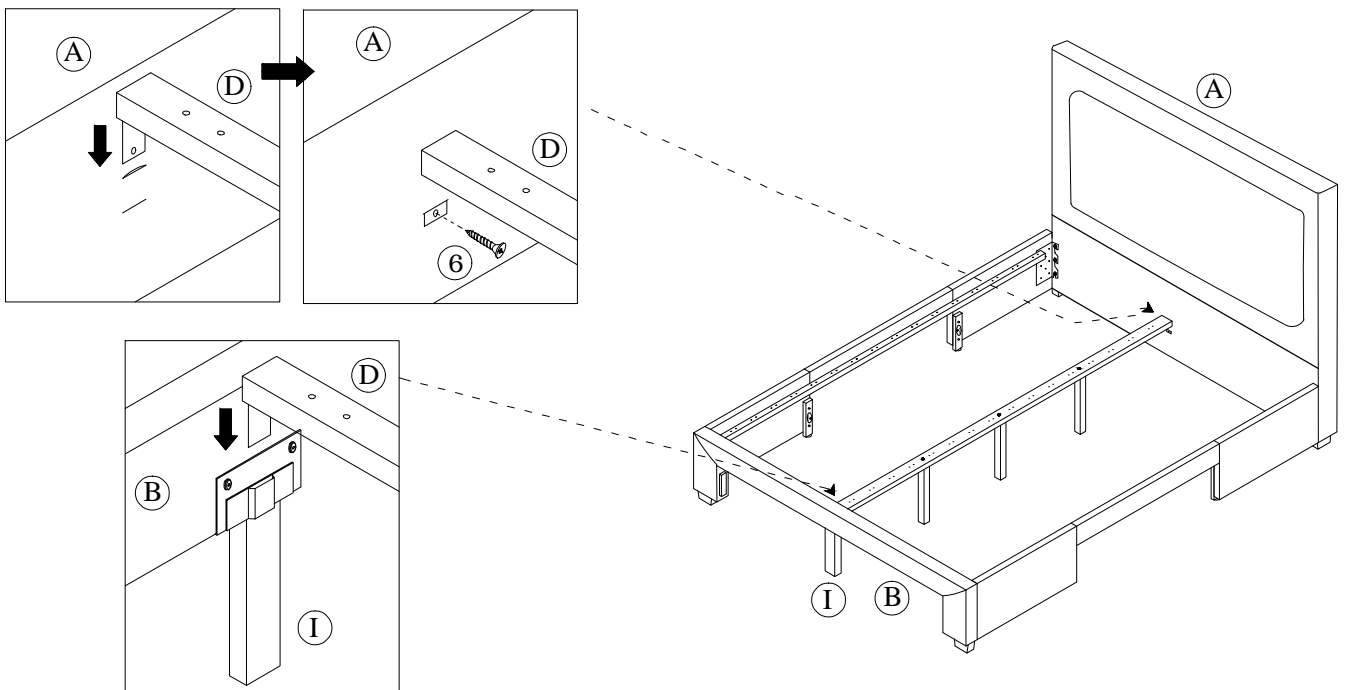

STEP 7

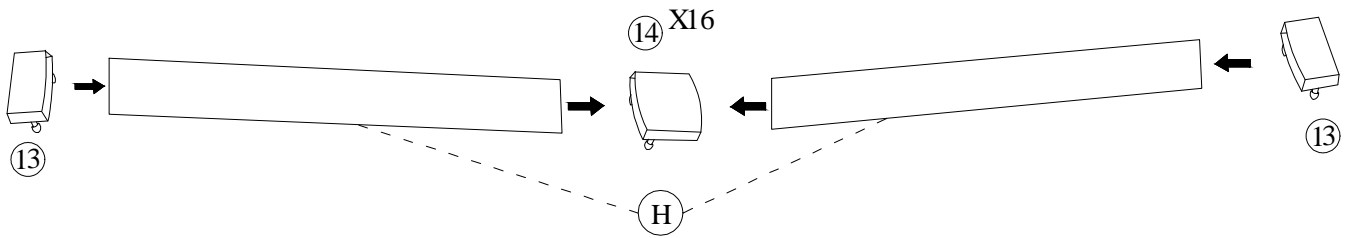

STEP 8

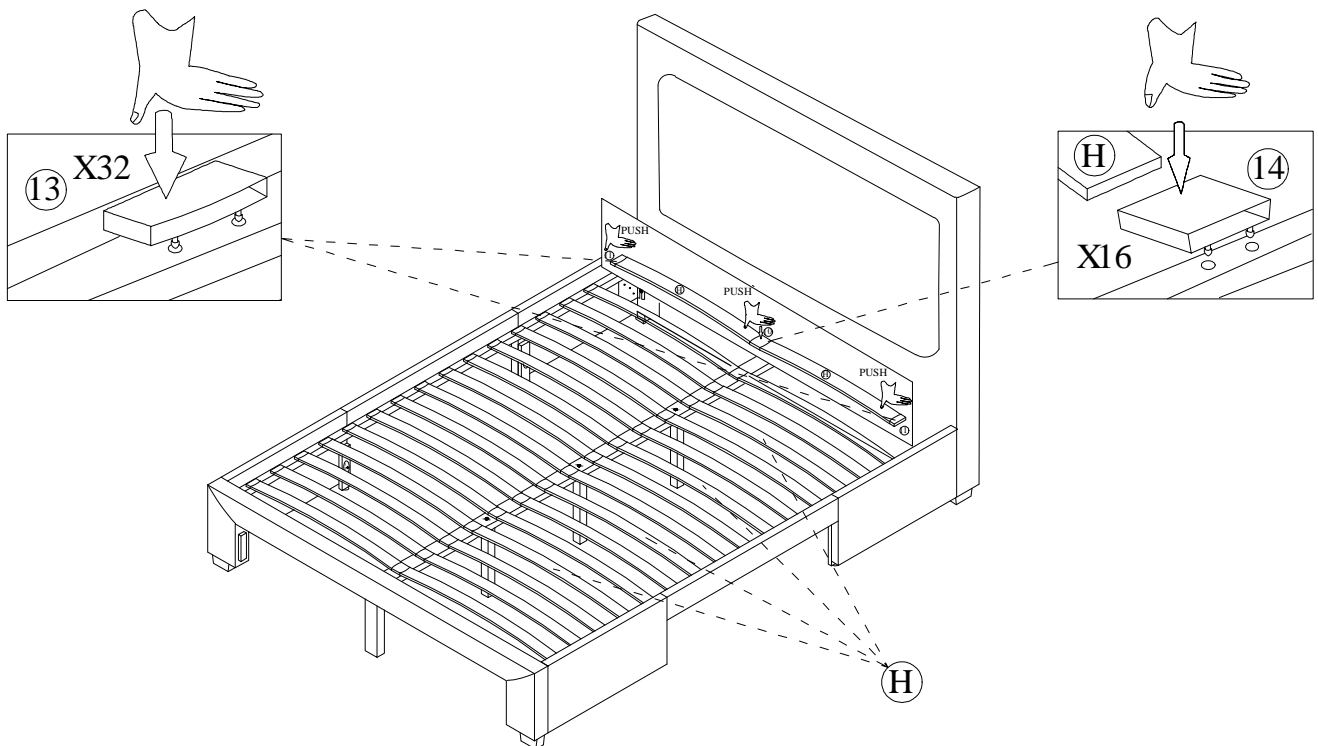

STEP 9 side Drawer Assembly

Important:
Make sure when you fit the nuts
that the hole is in the correct
alignment.

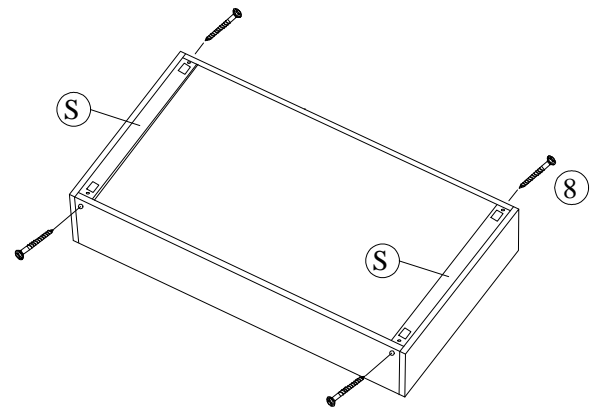
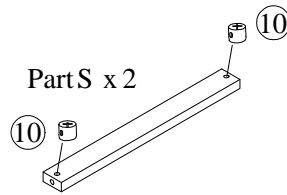
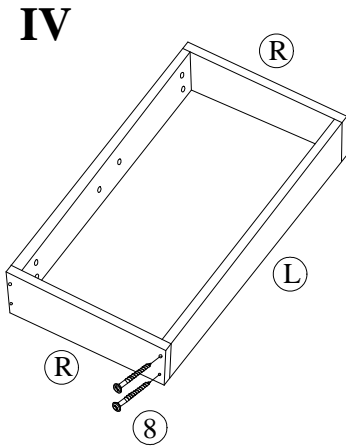
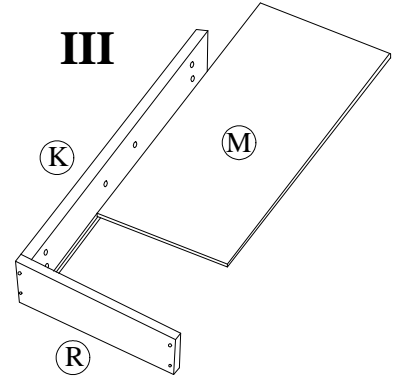
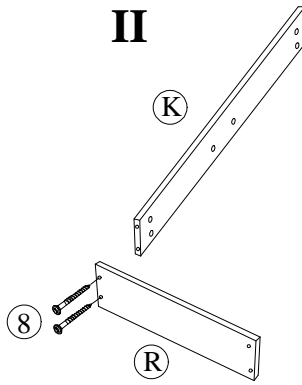
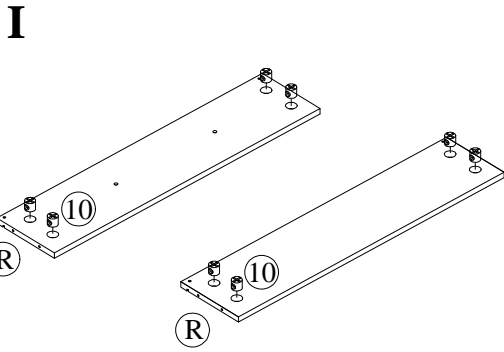
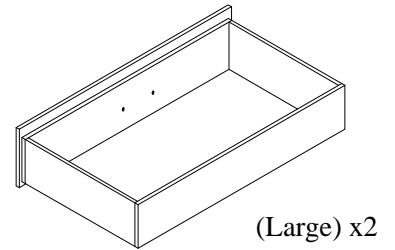
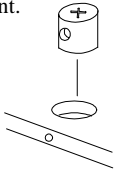

STEP 10 Positions For Castors.

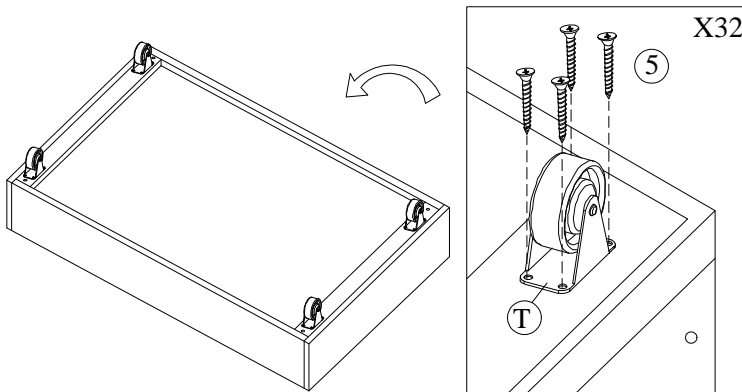

FOLLOW LINE ON BACK OF
DRAWER FACE PANEL

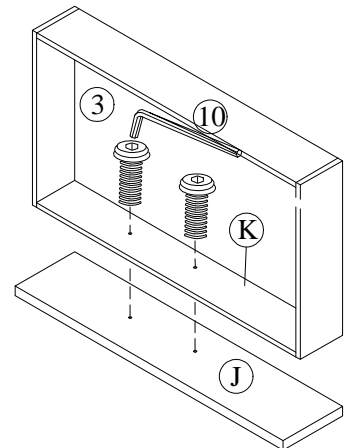

STEP 11 Footend Drawer Assembly

Important:
Make sure when you fit the nuts
that the hole is in the correct
alignment.

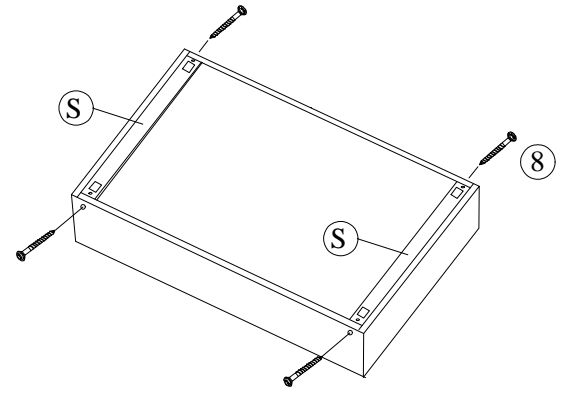
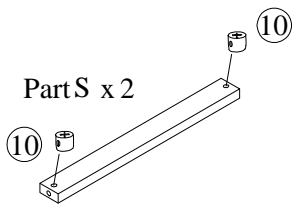
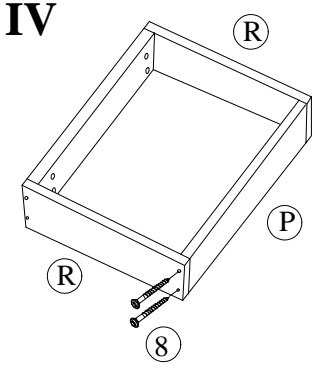
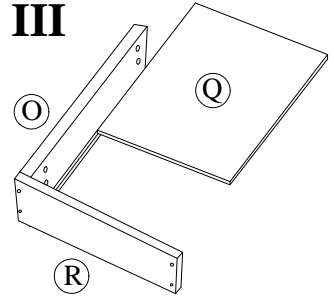
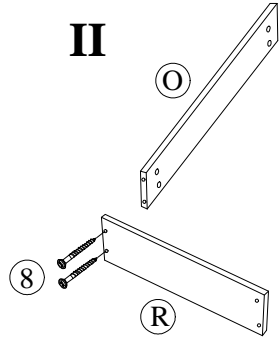
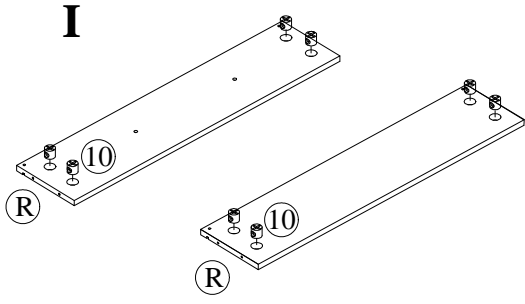
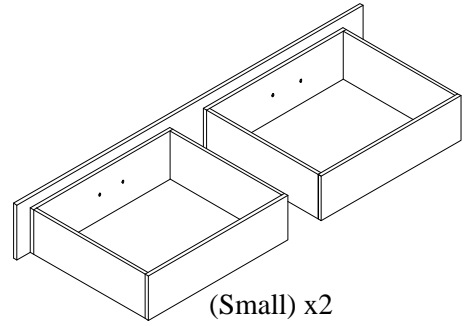
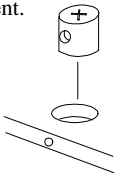

STEP 12 Positions For Castors.

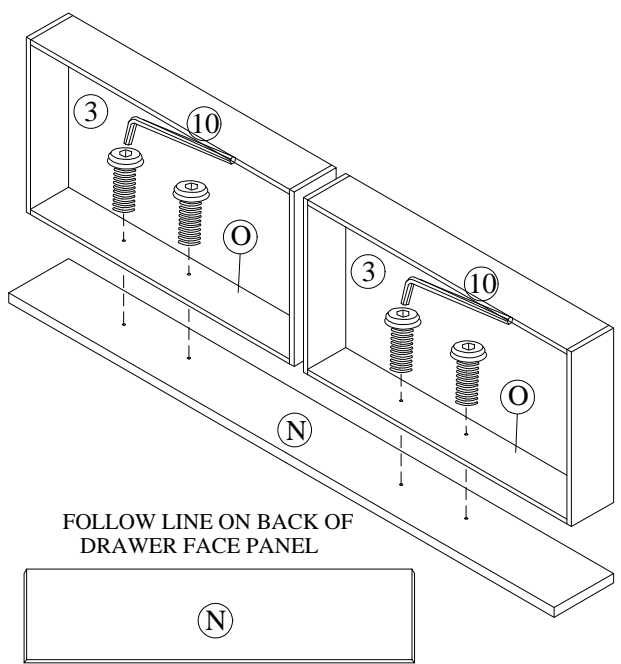
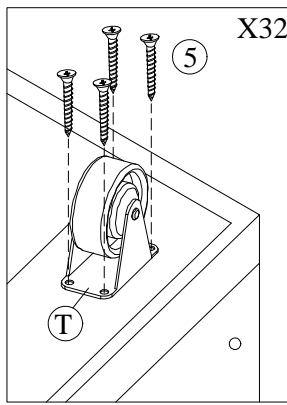
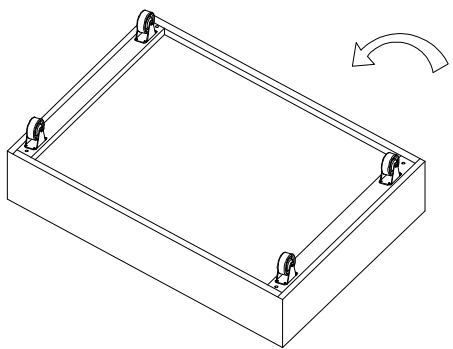

FOLLOW LINE ON BACK OF
DRAWER FACE PANEL

STEP 13

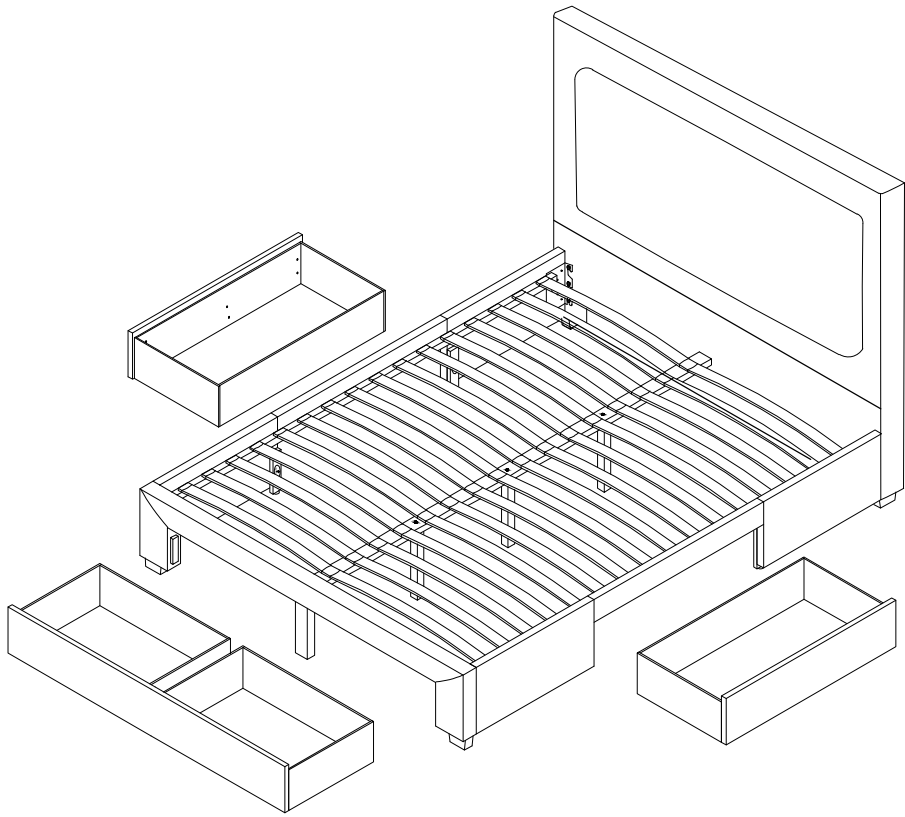

General Care

Wipe clean with a slightly damp soft cloth.

Avoid the use of all household cleaners and abrasives.

When moving your furniture, carefully lift into place. Never drag or push the pieces across the floor as this will cause damage to the joints and could result in failure to the product that will invalidate the warranty.

Recommendations

Periodical re-tightening of fixings.

Warning

The centre support legs on this product should be raised by 5mm from the floor with the added weight of the mattress and bedding. If the bed is to be moved, carefully lift the product rather than dragging to ensure that the centre legs do not become twisted and buckle.

Notes

We've tried to make this piece of furniture as easy to assemble as possible. In the unlikely event that you have problems putting it together or have damaged or missing pieces, please contact our customer services on 01623 727374

JULIAN BOWEN

Bentinck House, Park Lane Business Park, Kirkby-in-Ashfield, Notts NG17 9LE
Tel: (01623) 727374 Fax: (01623) 754555 Email: sales@julian-bowen.co.uk Web:julian-bowen.co.uk

EN:

In compliance with the EU General Product Safety Regulation (2023), Julian Bowen Limited has authorised the person named below to perform the tasks specified in the Regulation.

Name: Aris Christos Botsios Engineering Office

Address: V. Botsiou 3 Street, Eleousa, Ioannina, 45500, Greece

Email: acsbotsios82@gmail.com

Telephone: 00302651063075 (landline)

DE:

In Übereinstimmung mit der EU-Verordnung über die allgemeine Produktsicherheit (2023) hat Julian Bowen Limited die unten genannte Person ermächtigt, die in der Verordnung genannten Aufgaben wahrzunehmen.

Name: Aris Christos Botsios Ingenieurbüro

Adresse: V. Botsiou 3, Eleousa, Ioannina, 45500, Griechenland

E-Mail: acsbotsios82@gmail.com

Telefon: 00302651063075 (festnetz)

IT:

In conformità con il Regolamento Generale Sulla Sicurezza dei Prodotti dell'UE (2023), Julian Bowen Limited ha autorizzato la persona indicata di seguito a svolgere i compiti specificati nel Regolamento.

Nome: Aris Christos Botsios Ufficio tecnico

Indirizzo: V. Botsiou 3, Eleousa, Ioannina, 45500, Grecia

Email: acsbotsios82@gmail.com

Telefono: 00302651063075 (linea fissa)

FR:

Conformément au règlement de l'UE sur la Sécurité Générale des Produits (2023), Julian Bowen Limited a autorisé la personne nommée ci-dessous à effectuer les tâches spécifiées dans le règlement.

Nom: Aris Christos Botsios Bureau d'études

Adresse: V. Botsiou, Eleousa, Ioannina, 45500, Grèce

Courriel: acsbotsios82@gmail.com

Téléphone: 00302651063075 (ligne fixe)

ES:

En cumplimiento del Reglamento de la UE relativo a La Seguridad General de Los Productos (2023), Julian Bowen Limited ha autorizado a la persona nombrada a continuación a realizar las tareas especificadas en el Reglamento.

Nombre: Aris Christos Botsios Oficina de Ingeniería

Dirección: V. Botsiou 3, Eleousa, Ioannina, 45500, Grecia

Correo electrónico: acsbotsios82@gmail.com

Teléfono: 00302651063075 (teléfono fijo)

SE:

I enlighet med EU förordning om allmän produktsäkerhet (2023) har Julian Bowen Limited bemyndigat den person som anges nedan att utföra de uppgifter som anges i förordningen.

Namn: Aris Christos Botsios Ingenjörbyrå

Adress: V. Botsiou 3 Street, Eleousa, Ioannina, 45500, Grekland

E-post: acsbotsios82@gmail.com

Telefon: 00302651063075 (fast telefon)

NL:

In overeenstemming met de EU-verordening inzake algemene productveiligheid (2023) heeft Julian Bowen Limited de hieronder vermelde persoon gemachtigd om de in de verordening gespecificeerde taken uit te voeren.

Naam: Aris Christos Botsios Ingenieursbureau

Adres: V. Botsiou 3 Street, Eleousa, Ioannina, 45500, Griekenland

E-mail: acsbotsios82@gmail.com

Telefoon: 00302651063075 (vaste lijn)