

Fitting with mantle set 2

Step 1

Open the fire carton and take out the product (retain all packaging) Unscrew the wall mounting bracket that is fixed on the upper left and right side of the fire by 2 screws.

Step 2

Locate position of mounting bracket by measuring up from the floor 750 mm to it's lower edge. Mark the position of 5 screw holes (2 either side and 1 centre) and drill them using a suitable sized drill bit for the raw plugs supplied.

Step 3

Push the plastic raw plugs into the five holes, or use a suitable fixing for plasterboard walls. Then use the ST5*40 screws to attach the bracket onto the wall.

Step 4

Hook the fire back on the bracket, and using the ST4*8 screws (put to a side in step one) and attach the bracket to the fire.

Assembly of lower mantle:

Unpack the mantle and retain the packaging.

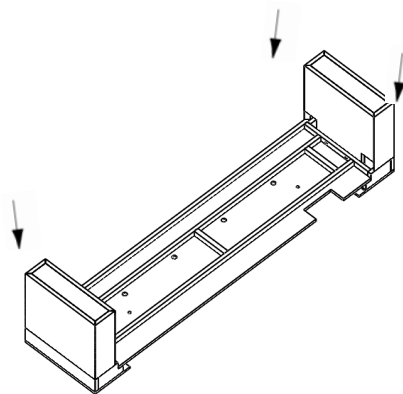

Step1. slot the lower leg sections onto the base of the fire This is best done placing the lower wooden section upside down on a soft clean surface.

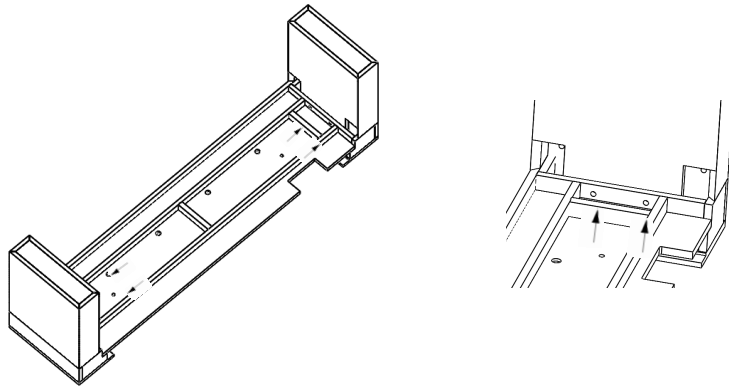

Step 2. Fix two screws on both sides .

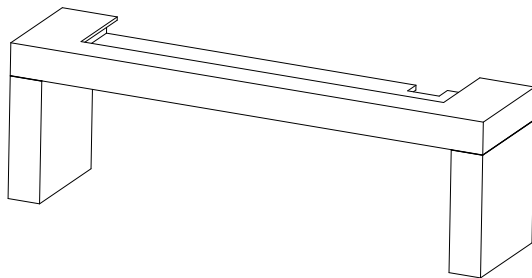

Step 3. Finish the assembly of the lower wood mantle set.

Step 4

Slide the lower mantle assembly onto the fire. Connecting the LED fly lead from the mantle to the fire. (please not: this cable sits between the fire and mantle base) Secure to fire using the two M5*25 screws and washers. (Note: Location of fix points are on underside of the lower mantle towards the rear of the fire)

Located

Note: Do not attempt to slide the lower mantle into position before the fire is firmly secured to the wall.

Step 5 Upper mantle

Take out the top panel and slide into position on the fire and secure with the thumb screws provided.