

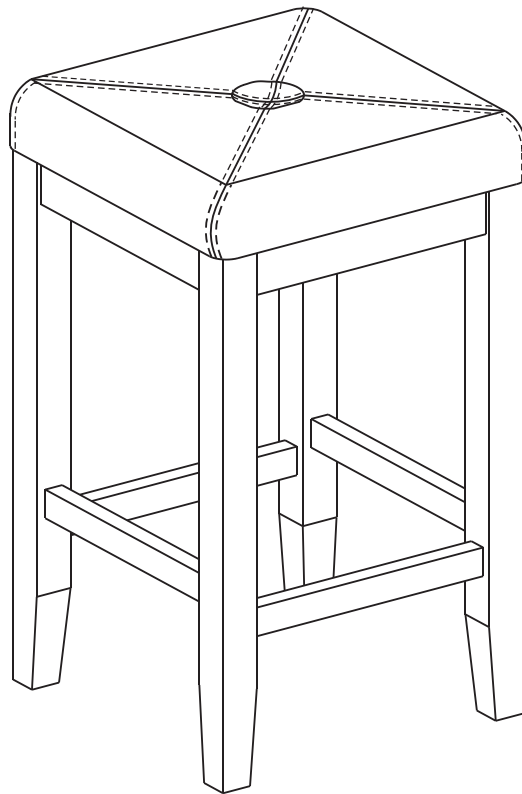

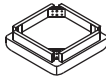





Bar Stool



ASSEMBLY INSTRUCTIONS

DESCRIPTION: 24 "/29" Bar Stool

Part Lists			
No.	Description	Sketch	Q'ty
A	SEAT FRAME		1 PC
B	LEG (RIGHT AND LEFT)		2 PAIR
C	SIDE STRETCHER		4 PCS

Hardware Lists			
No.	Description	Sketch	Q'ty
a	BOLT (5/16 x 60")		8 PCS
b	SPRING WASHER		8 PCS
c	FLAT WASHER		8 PCS
d	ALLEN WRENCH		1 PC
e	SCREW(#8X1-1/2")		8 PCS

Step 1

Attach left and right legs (B) to the seat frame (A) using the bolts (a), spring washers (b) and flat washers (c) as shown in Figure 1. **Do not tighten bolts at this time.**

Note: The left and right legs (B) are marked "R" & "L".

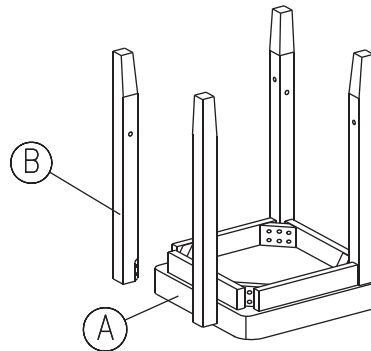

Step 3

Insert the side stretchers (C) into the left and right legs (B) as shown in Figure 2.

Note: If you have trouble inserting the stretchers, loosen the bolts (a) slightly to allow for extra space.

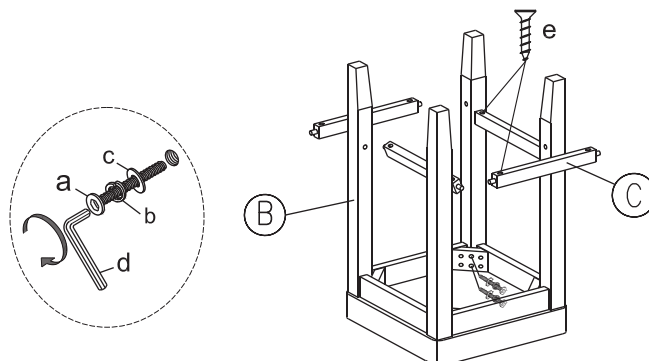

Step 4

Ensure that the side stretchers (C) are flush with legs (B). Secure with screws (e) using Phillips head screw driver. Finger-tighten the bolts (a).

Step 5

Turn stool upright on its legs and place on a flat, level floor. Make sure that the stool is level and square. Tighten all bolts (a) completely with supplied Allen wrench (d).