





ASSEMBLY INSTRUCTIONS & PARTS IDENTIFICATION

TABLE

Thank you for purchasing this quality product. Be sure to check all packing material carefully for small parts that may have come loose inside the carton during shipment.

Hardware kit (1838 - 72P01)				Parts Key			
No	Description	Q'Ty		No	Code	Description	Q'Ty
A	 Bolt 1/4" x 1-1/2"	8 pcs		1	1838-72P24	Table Top	1 Pc
B	 Lock washer	8 pcs		2	1838-72P53	Leg Assembly	2 Pcs
C	 Flat washer	8 pcs		3	1838-72P44	Side Stretcher	2 Pcs
D	 Allen Key	1 pc		4	1838 P01FT	Table Floor Glide	4 Pcs

STEP 1

- Carefully place the Table Top on the smooth surface.
- Insert the two Leg Assemblies to Table Top with Bolts (A), Lock Washers (B) & Flat Washer (C) using Allen key (D). Do not tighten the bolts at this step. (See Detail A).

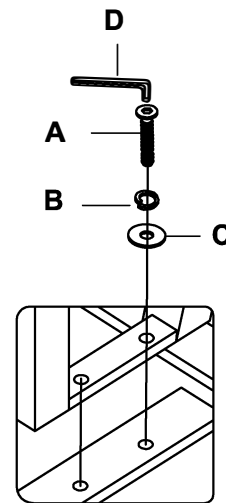
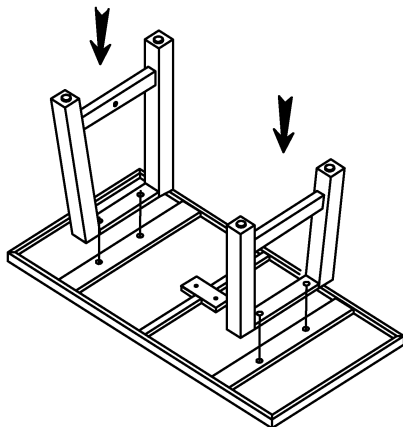

DETAIL A

STEP 2

- Attach the Side Stretcher to between the Leg Assembly and the Table Top with Bolts (A), Lock Washers (B) & Flat Washer (C) using Allen key (D). Tighten all bolts at this step. (See Detail B) & (See Detail C).

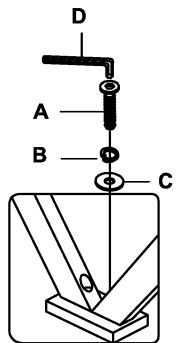

DETAIL C

DETAIL B

