

TWIN FULLY UPHOLSTERED BED

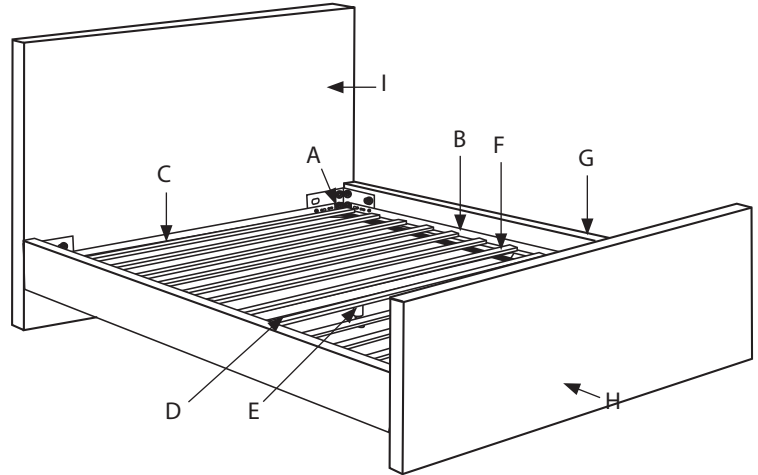







Components

ITEM	DESCRIPTION	QTY
A	Metal Corners	4
B	Metal Side Rail	2
C	Metal End Rail	2
D	Center Support Rail	1
E	Center Support Leg	1
F	Wooden Slat Roll	1
G	Upholstered Side Rail	2
H	Upholstered Foot Rail	1
I	Upholstered Headboard	1



Please note: actual product may look different than illustration.

HARDWARE

(H1) x 10	— 1/4" bolt		(H9) x 1	— wrench	
(H2) x 20	— 1/4" nut				
(H3) x 5	— 1" x 1/4" bolt				
(H4) x 4	— 3/4" washer smaller hole				
(H5) x 12	— 1" x 5/16" bolt				
(H6) x 10	— 2 1/2" x 5/16" bolt				
(H7) x 22	— 1 1/4" washer				
(H8) x 1	— smaller L wrench				

Please note: assembly is recommended with two people. You will need a flat head and phillips head screwdriver to assemble your bed frame.

Step 1

1.1

Place (A) metal corners in a rectangular shape roughly the size of your mattress.

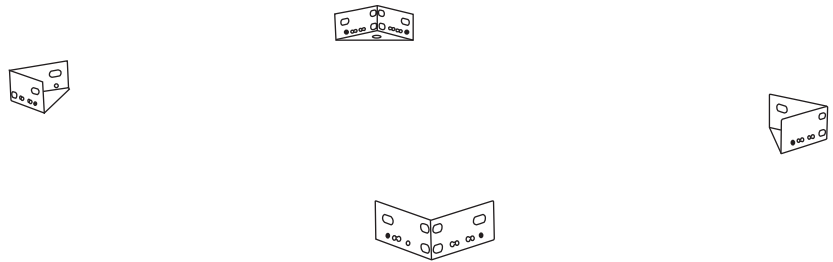

1.2

Lay (B) and (C) metal rails into (A) metal corners to create the shape of your bed frame. Snap into place.

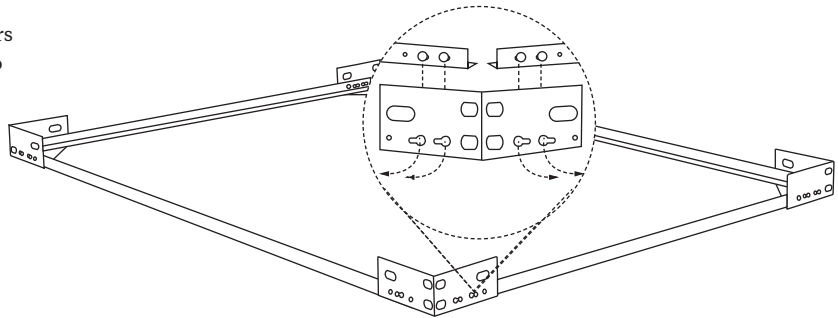

1.3

Secure (B, C) metal rails to (A) metal corners using (H1) bolts and (H2) nuts. Tighten using (H8) L wrench and (H9) wrench.

Please note: (H2) nuts should be on the inside of the frame.

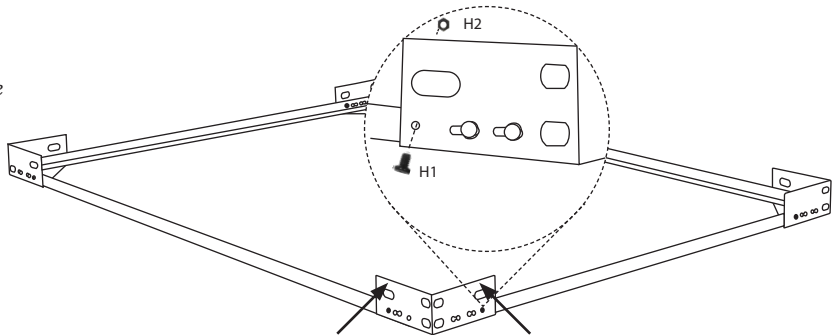

Step 2

2.1

Loosely attach (I) headboard using (H6) bolts, (H7) washers and a flat head screwdriver.

Please note: We recommend one person attaches the headboard while another holds the metal bed frame.

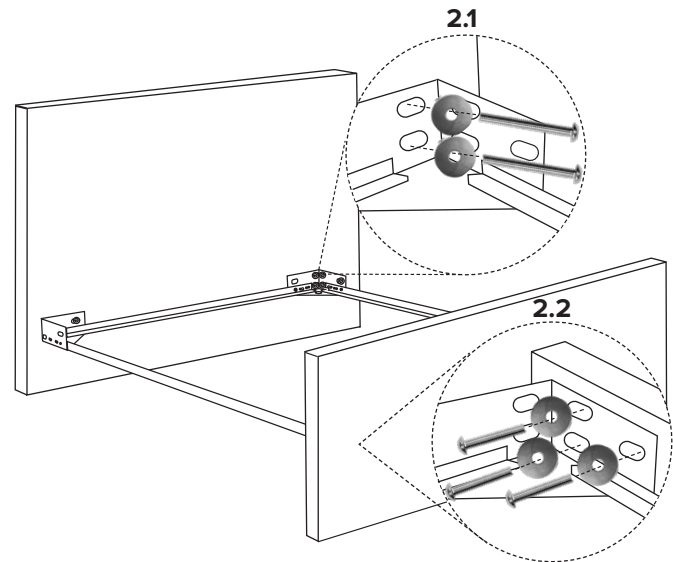

2.2

Loosely attach (H) upholstered footrail to the metal bed frame using (H6) bolts, (H7) washers and a flat head screwdriver.

Please note: We recommend one person attaches the headboard while another holds the metal bed frame.

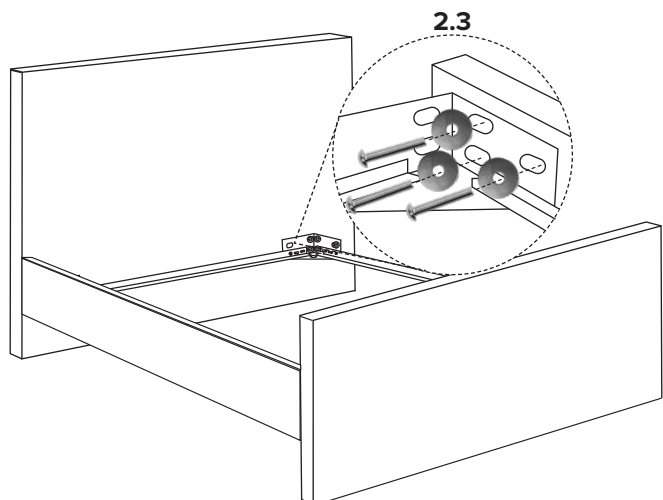

2.3

Loosely attach (G) upholstered side rails to the metal bed frame using (H5) bolts, (H7) washers and a flat head screwdriver.

Please note: we recommend one person hold the frame and upholstered pieces in place while a second person attaches the hardware.

Step 3

3.1

Align holes of (D) center support rail with holes on (B) metal side rails. Attach using (H1) bolts and (H2) nut. Tighten using (H8, H9) wrenches.

Please note: (D) center support rail attaches underneath (B) metal side rails.

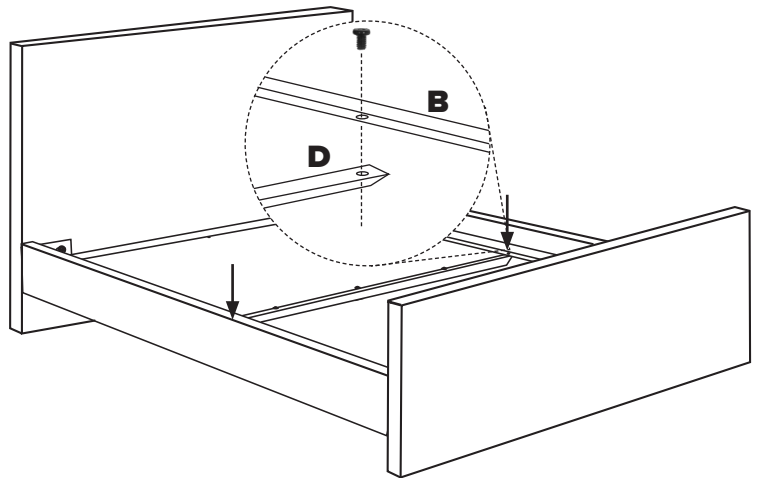

3.2

Attach (E) center support leg to (D) support rail using (H3) bolts and (H4) washer. Tighten using (H8) L wrench.

Please note: (F) center support legs can be adjusted in height by twisting the foot at the bottom of the leg. Ensure (D) center support rail is level.

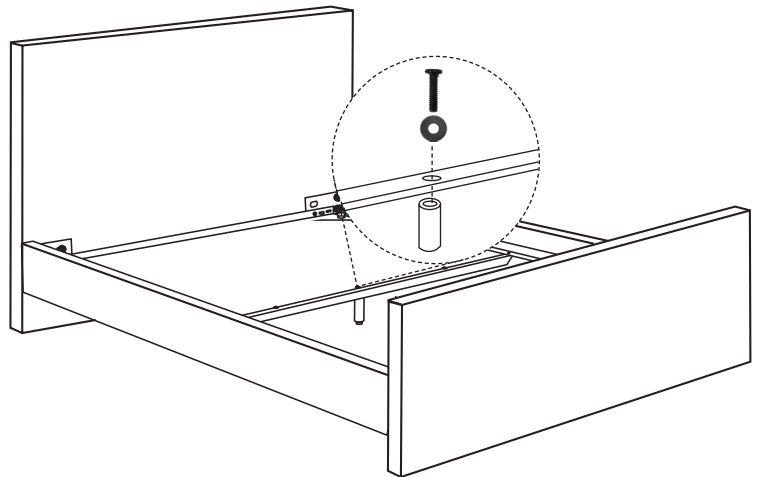

Step 4

4.1

Carefully place the (F) wooden slat rolls onto the bed frame. Attach using (H3) bolts and (H2) nuts. Tighten with (H8, H9) wrenches.

Please note: The black band that holds the slats together should face the floor.

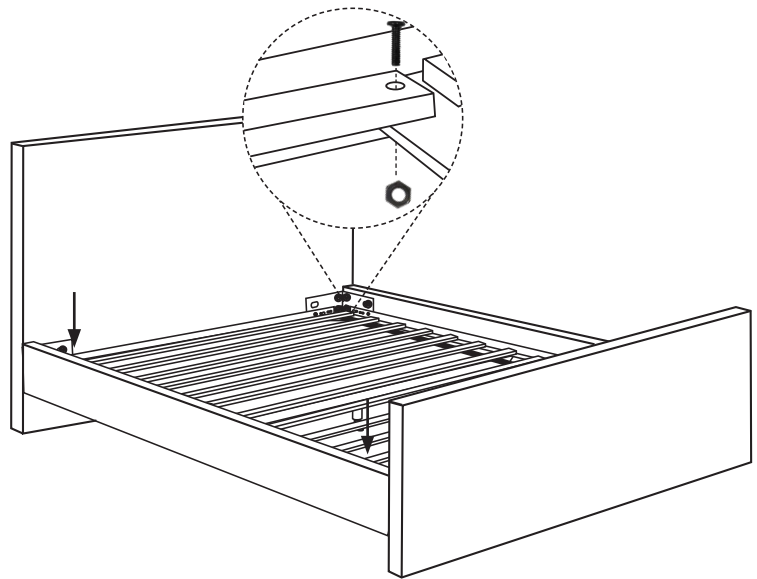

4.2

Fasten all hardware tightly on (I) headboard, (H) footrail, and (G) side rails.

Please note: (G) side rails should line up flush with (H) foot rail.

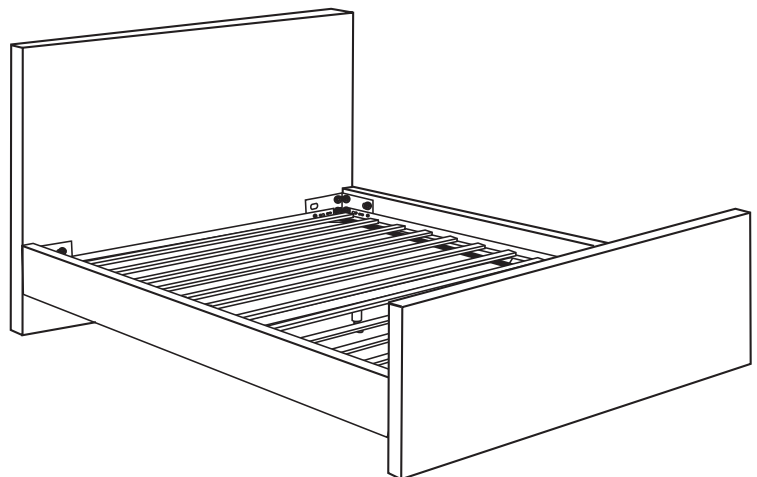

Warranty

LIMITED WARRANTY

Skyline Furniture Inc. guarantees its upholstered furniture against defects in construction for a period of one (1) year. When a structural defect is brought to our attention, we will repair or replace it at our option at no charge to the customer (includes parts and labor, not transportation costs). Fabric wearability for upholstered furniture is not covered by the warranty. Vacuum for regular cleaning.

Please dispose of plastic bag(s) and carton(s) responsibly.

LIMITE DE GARANTIA

Skyline Furniture Inc. garantiza sus muebles tapizados contra defectos en construcción por un período de un (1) año. Cuando un problema de estructura es traído a nuestra atención, nosotros repararemos o remplazaremos sin ningún cargo a nuestro cliente (incluye partes y trabajo, no costo en transportación). Descoloramiento del material de muebles tapizados no es cubierto por la garantía. Regularmente puede aspirar.

Por favor tirar bolsa(s) y caja(s) responsablemente.

GARANTIE LIMITÉE

Skyline Furniture Inc. garantiza sus muebles tapizados contra defectos en construcción por un período de un (1) año. Cuando un problema de estructura es traído a nuestra atención, nosotros repararemos o remplazaremos sin ningún cargo a nuestro cliente (incluye partes y trabajo, no costo en transportación). Descoloramiento del material de muebles tapizados no es cubierto por la garantía. Regularmente puede aspirar.

Por favor tirar bolsa(s) y caja(s) responsablemente.