

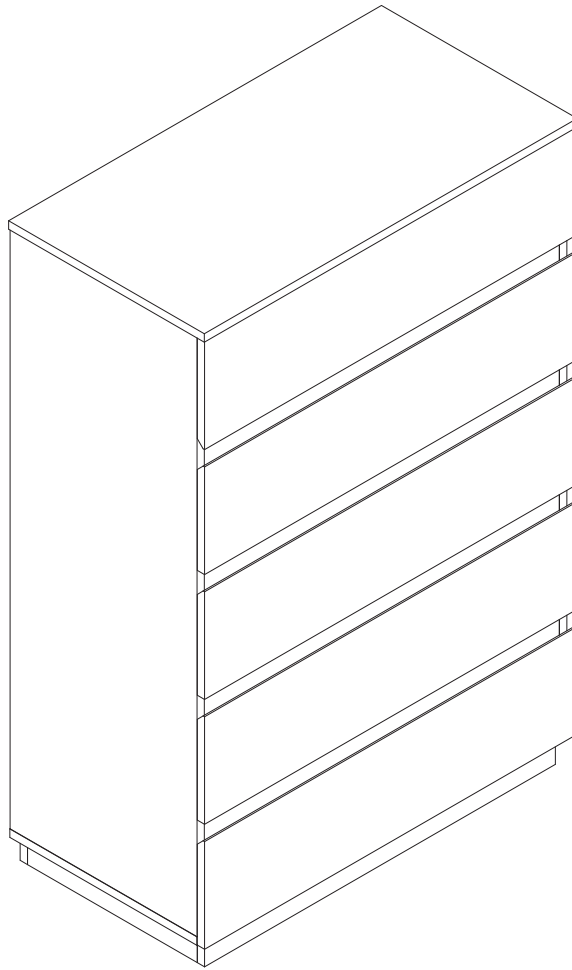

# VINGLI 5 DRAWER DRESSER

ASSEMBLY INSTRUCTION



Thank you for purchasing from VINGLI!  
Please contact us via email if parts are missing or damaged, we will gladly ship your replacement parts free of charge

**⚠ IMPORTANT**

THIS INSTRUCTION BOOKLET CONTAINS IMPORTANT SAFETY INFORMATION.  
PLEASE READ AND KEEP FOR FUTURE REFERENCE.

# RETURN & WARRANTY

## Thank you for choosing our product!

We would like to take this opportunity to thank you for choosing VINGLI.

We hope that you are completely satisfied with your purchase, and enjoy it for years to come.

## Your satisfaction is our highest pursuit.

## Return policy

VINGLI believes you will absolutely love your furniture, but if for some reason you want to return the product, please contact us directly before you decide to return your product to the retailer. Our Customer Service organization can answer most concerns and can assist you with any questions you may have about your new product.

The item must be returned in good condition, in original box, with all original proof of purchase, parts and accessories, within the time frame specified by the retailer it was purchased from.

## Warranty

VINGLI warrants this product to be free from defects in material and workmanship agrees to remedy any such defect. This warranty covers one year from the date of original purchase. This is solely limited to be repair or replacement of defective parts and no assembly labor is included.

This warranty does not apply to any product which has been improperly assembled, subjected to misuse or abuse or which has been altered or repaired in any way.

Components repaired or replaced warranted through the remainder of the original warranty period only. The defective components will be repaired or replaced without charge, subject to the terms and conditions described above.

For help with assembly, identifying parts, product information or to order parts, please contact us freely.

# BEFORE STARTING

## Before Using Product



- Read each step carefully before starting. It is very important that each step is performed in the correct order. If these steps are not followed in sequence, assembly difficulties will occur.



- Make sure all parts are included. Most board parts are labeled or stamped on the raw edge.

- Prepare a flat and Philips screwdriver (not included)  
A Power Screwdriver is recommended.



- Work in a spacious area and near where the unit will be used, preferably on a carpet, or use a piece of the cardboard packaging to protect your floor and product.



- For a smooth assembly process, we suggest you keep a lite tightness for all the screws during assembly. After the whole product is assembled, firmly tighten all the screws.

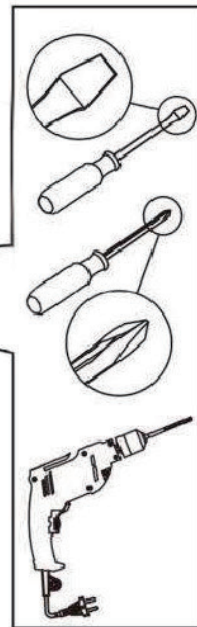

Estimated People for Assembly

2

## WARNING:

- Do not allow children to climb on unit
- Serious or fatal crushing injuries can occur from furniture tip-over. To prevent this furniture from tipping over, it must be permanently fixed to the wall. Fixing devices for the wall are not included since different wall materials require different types of fixing devices. Use fixing devices suitable for the walls in your home. For advice on suitable fixing systems, contact your local specialized dealer
- Avoid sharp objects or corrosive chemicals to prevent damage to the product
- During assembly, keep parts and packaging materials away from children and pets as there could be potential injury and choking hazards

# IDENTIFY PARTS

One unit

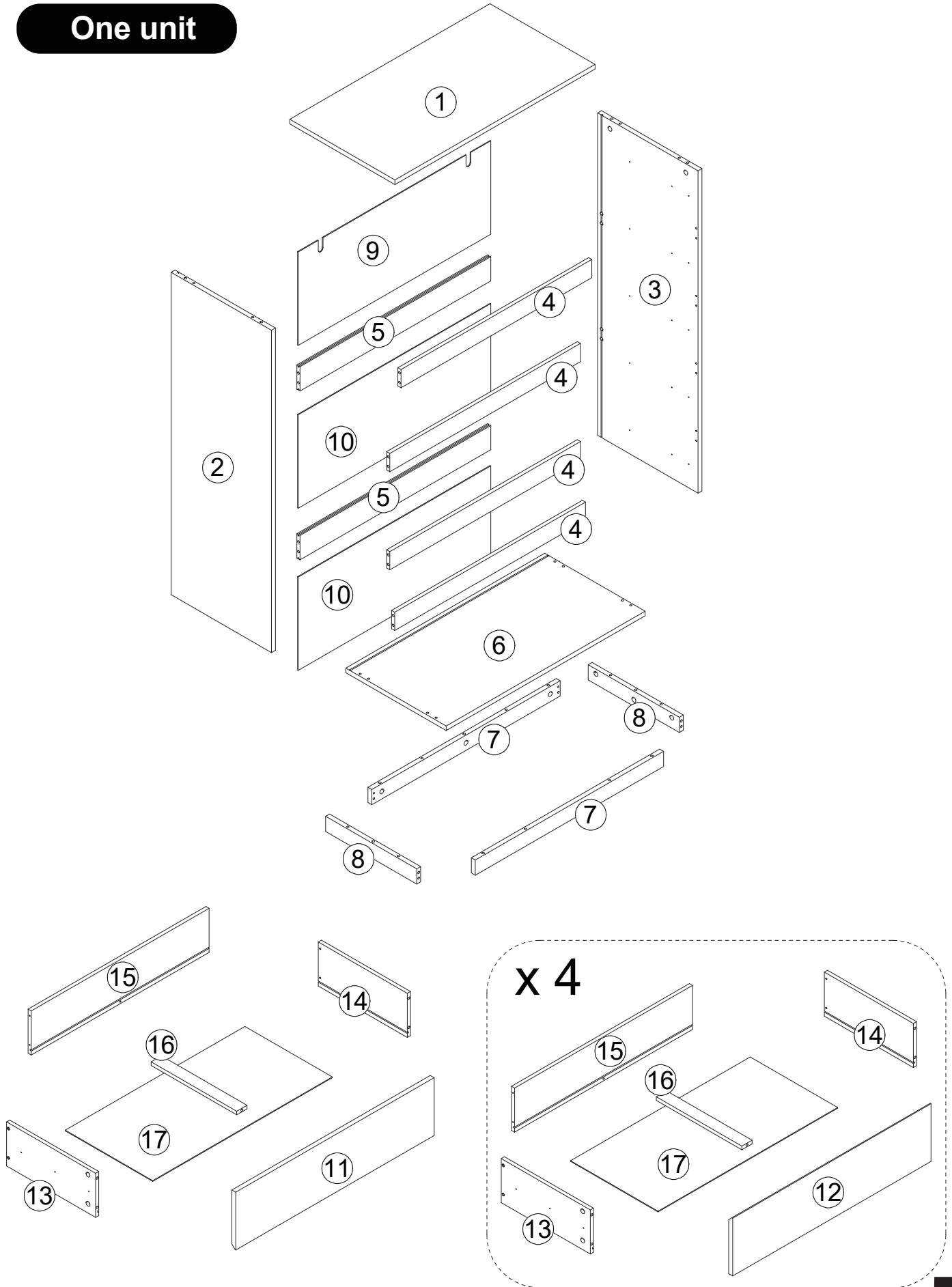

# COMPONENTS

1

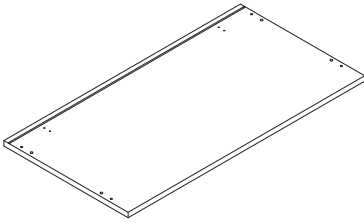

760×399×15mm

Top Panel x1

2

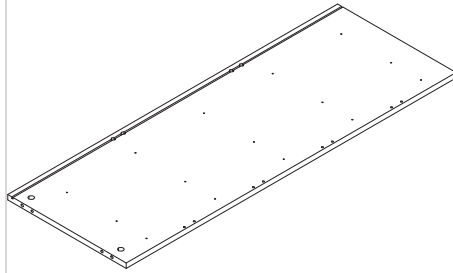

1060×381×15mm

Left Side Panel x1

3

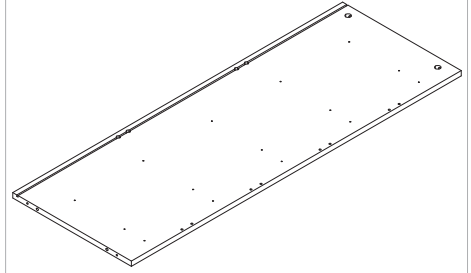

1060×381×15mm

Right Side Panel x1

4

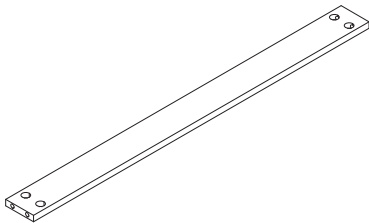

724×60×12mm

Front Wood Strip x4

5

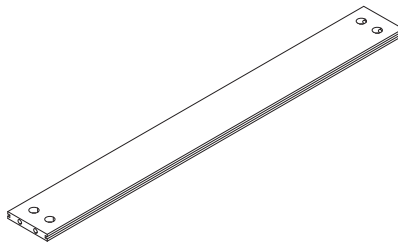

724×80×12mm

Rear Wood Strip x2

6

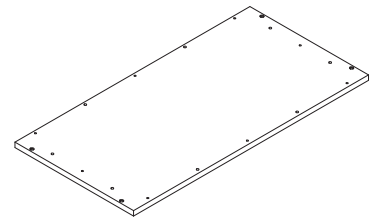

755×381×15mm

Bottom Panel x1

7

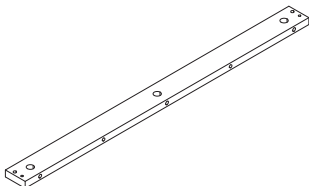

715×50×15mm

Bottom Brace Panel I x2

8

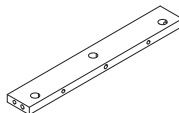

346×50×15mm

Bottom Brace Panel II x2

9

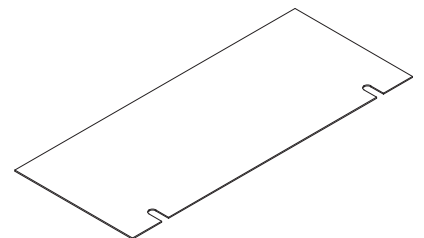

731×307mm

Upper Back Panel x1

# COMPONENTS

10

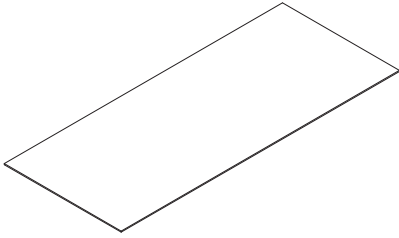

731×307mm

Lower Back Panel x2

11

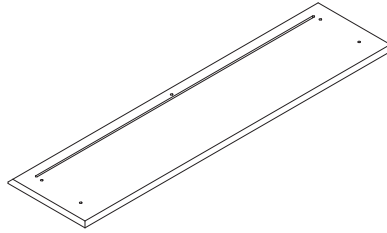

753×190×15mm

Upper Drawer Front Panel x1

12

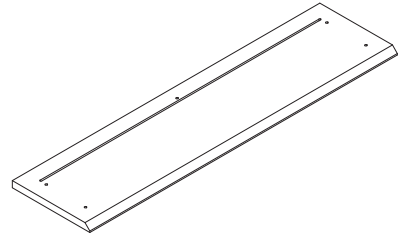

753×190×15mm

Lower Drawer Front Panel x4

13

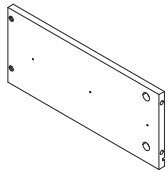

338×145×12mm

Drawer Left Panel x5

14

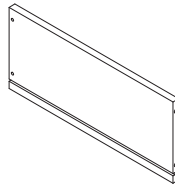

338×145×12mm

Drawer Right Panel x5

15

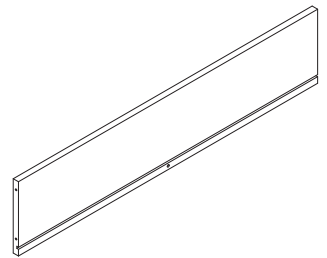

675×145×12mm

Drawer Back Panel x5

16

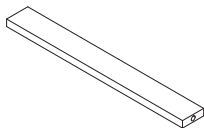

325×39×12mm

Drawer Wood Strip x5

17

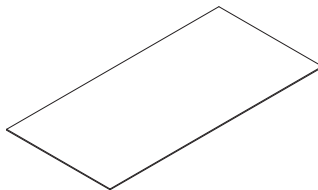

682×332mm

Drawer Bottom Panel x5

# COMPONENTS

**A**

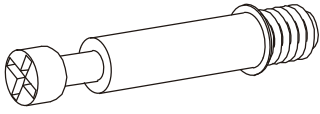

+6(spare)

Φ6X35mm

Cam Bolt x65

**B**

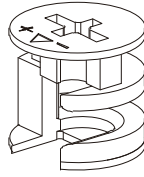

+6(spare)

Φ15X10mm

Cam Lock x65

**C**

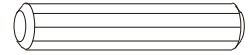

+2(spare)

Φ6X30mm

Wood Dowel x20

**D**



+2(spare)

Φ4X35mm

Screw x25

**E**



+6(spare)

Φ3X12mm

Screw x60

**F**



Φ5X40mm

Screw x4

**G**

G-1

G-2

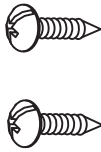
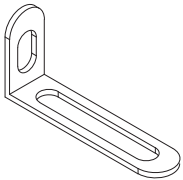

Φ4X12mm

L-shaped Bracket & Screw x2

**H**

H-1

H-2



Φ4X45mm

Plastic Anchor & Screw x 2

**I**

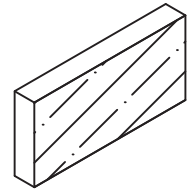

25x12mm

Foot Pad x4

**J**

J-1

J-2

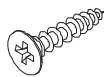
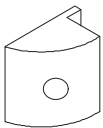

+1(spare)

Φ3X16mm

Back Panel Wedge & Screw x12

**K**

K-1

K-2

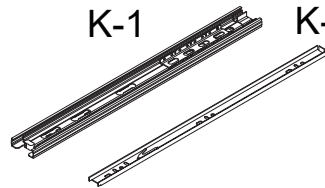

L350mm

Three-section Drawer Slide x10

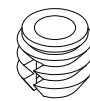

(spare)

Plastic Anchor x4

# ASSEMBLY STEPS

\* Before assembling the drawer slide, it needs to be disassembled first. As shown in the figure, press the detaching button on the side of the drawer slide to separate it into two parts, K-1 and K-2.

\* Please grip the K-1 part while sliding the K-2 part.

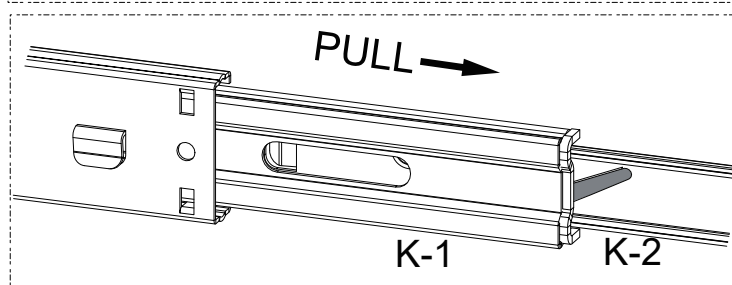
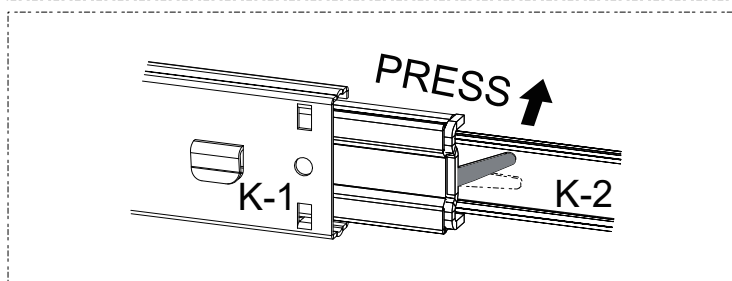
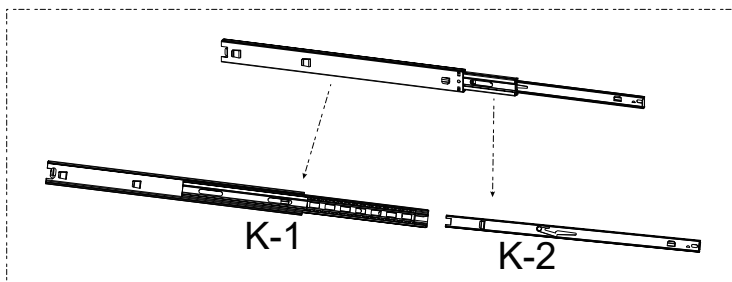

Please scan this QR code to access the video instructions on how to install the three-section slide rail.

## "A & B" Hardware installation example

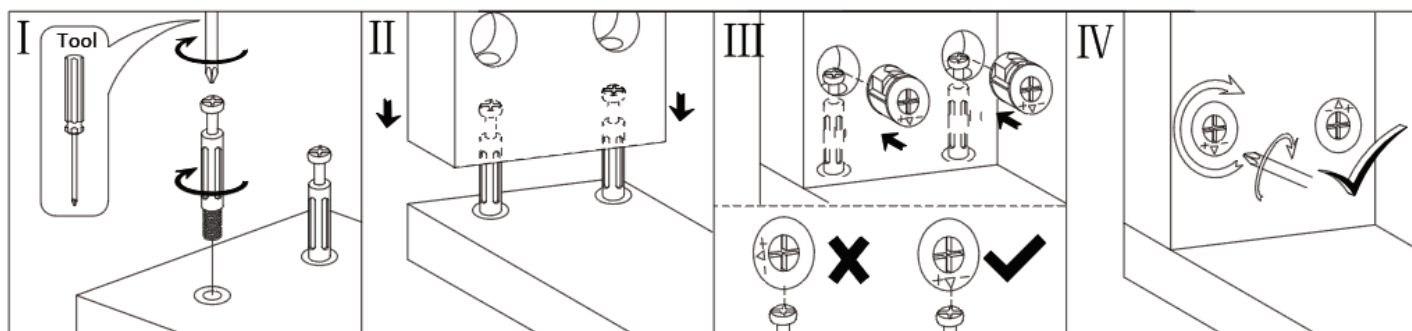

# ASSEMBLY STEPS

A x 8	 $\Phi 6 \times 35 \text{mm}$	G x 2	 $\Phi 4 \times 12 \text{mm}$ 
-------	--	-------	---

## STEP 1

1. Fix the cam bolt (A) into panels (1), (7).
2. Fix the L-shaped bracket (G-1) to panel (1) with screw (G-2).



Please scan this QR code to access the video instructions on how to install components such as the cam lock and the cam bolt.

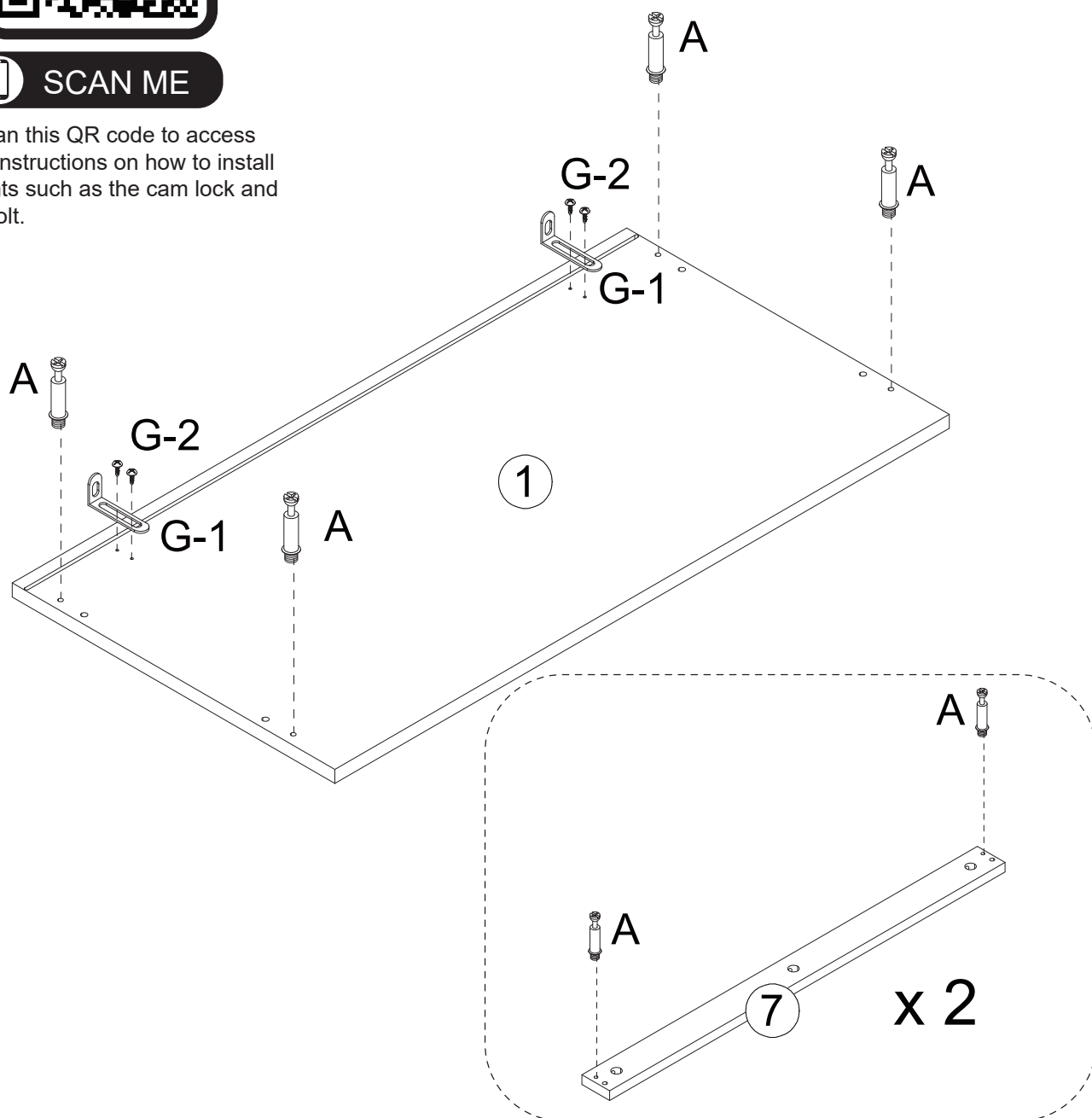

# ASSEMBLY STEPS

A x 12	$\Phi 6 \times 35 \text{mm}$ 	E x 15	$\Phi 3 \times 12 \text{mm}$ 	K x 5	K-1 	L350mm
--------	---	--------	---	-------	---	--------

## STEP 2

1. Fix the three-section drawer slide (K-1) to the panel (2) with screw (E).
2. Fix the cam bolt (A) to the panel (2).

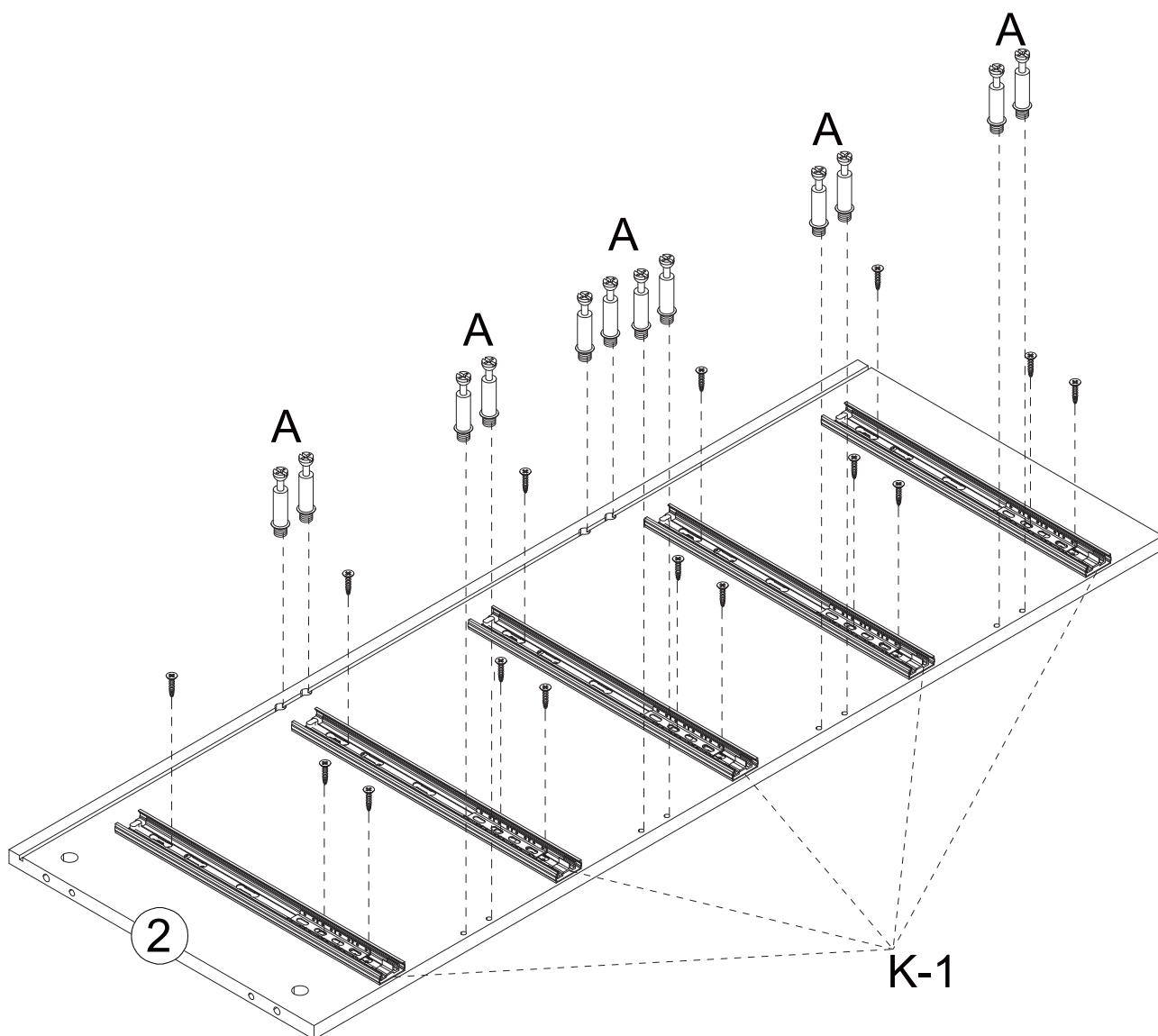
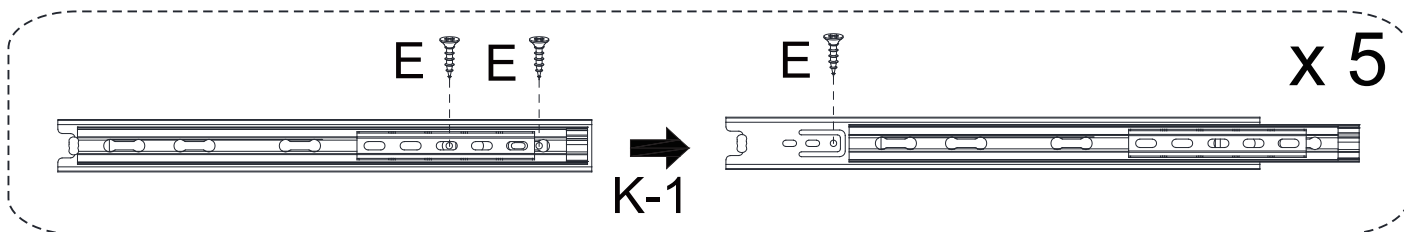

# ASSEMBLY STEPS

A x 12	$\Phi 6 \times 35 \text{mm}$ 	E x 15	$\Phi 3 \times 12 \text{mm}$ 	K x 5	K-1 
--------	---	--------	---	-------	---

## STEP 3

1. Fix the three-section drawer slide (K-1) to the panel (3) with screw (E).
2. Fix the cam bolt (A) to the panel (3).

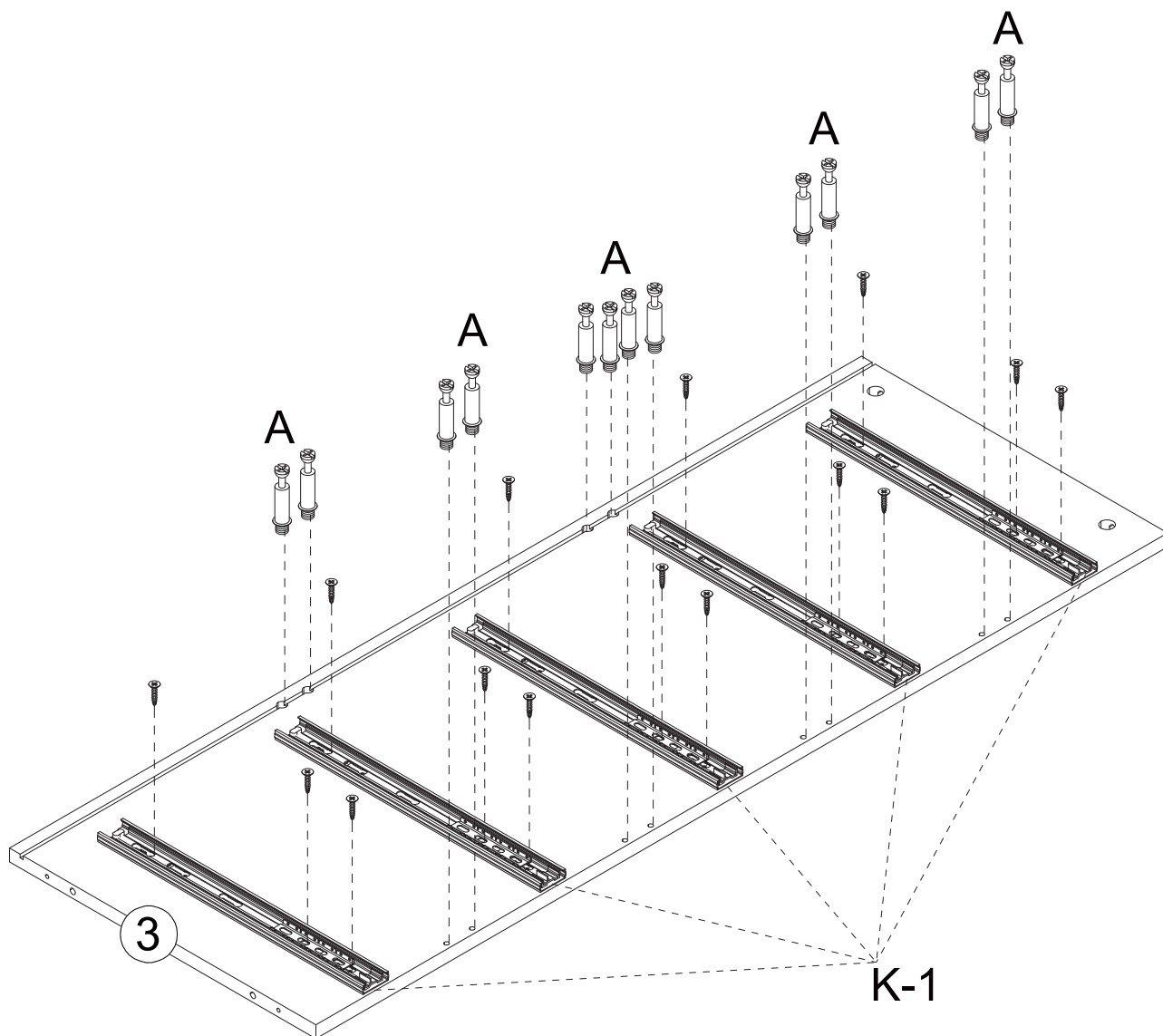
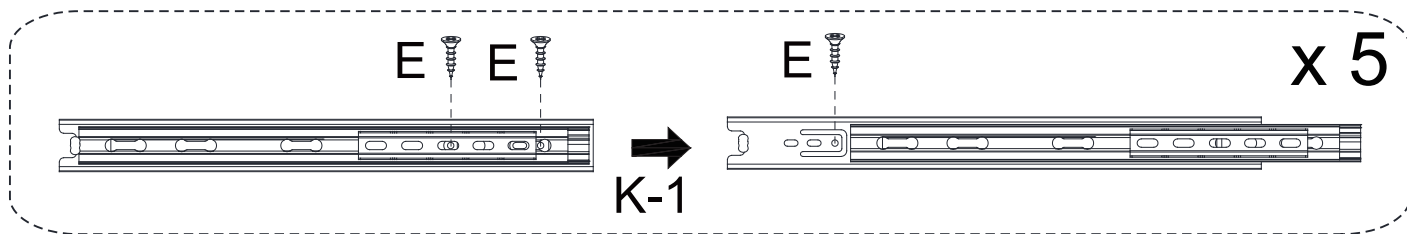

# ASSEMBLY STEPS

A x 33

Φ6X35mm



## STEP 4

Fix the cam bolt (A) to the panels (6), (11), (12).

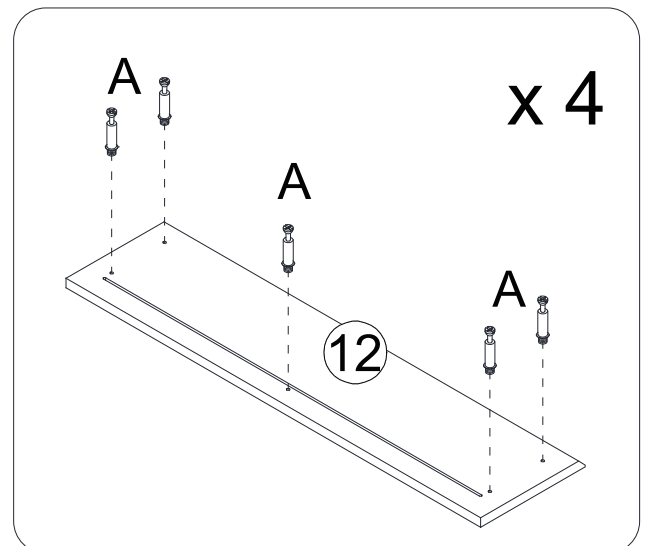
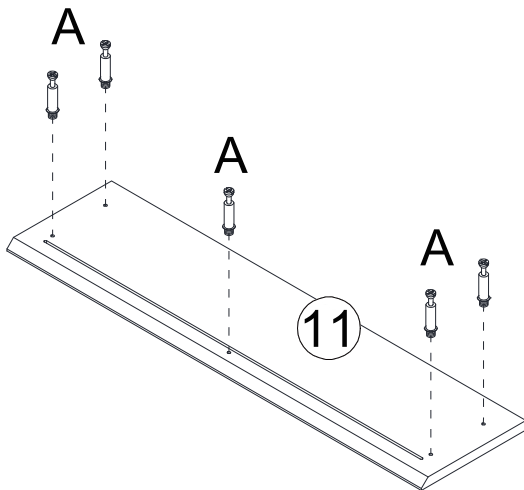
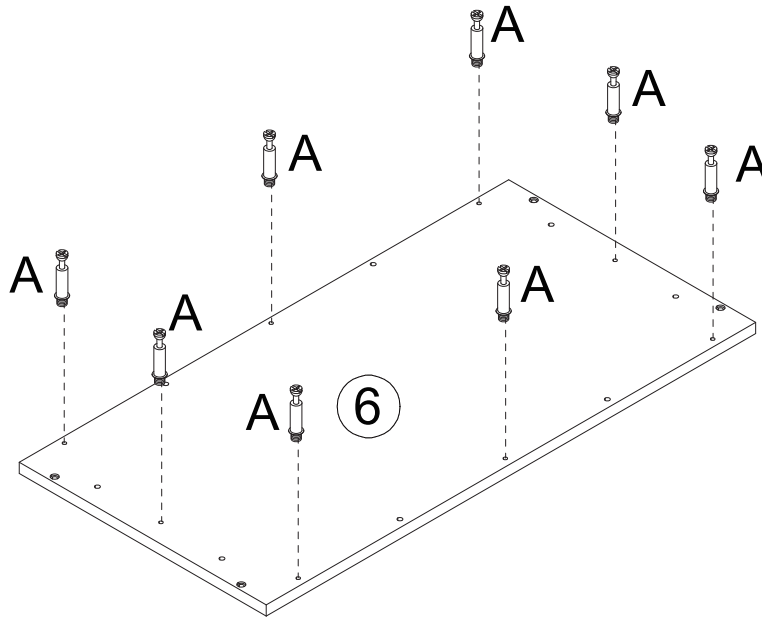

# ASSEMBLY STEPS

B x 12



## STEP 5

Connect panel (2) and wood strips (4), (5), then tighten with cam lock (B).

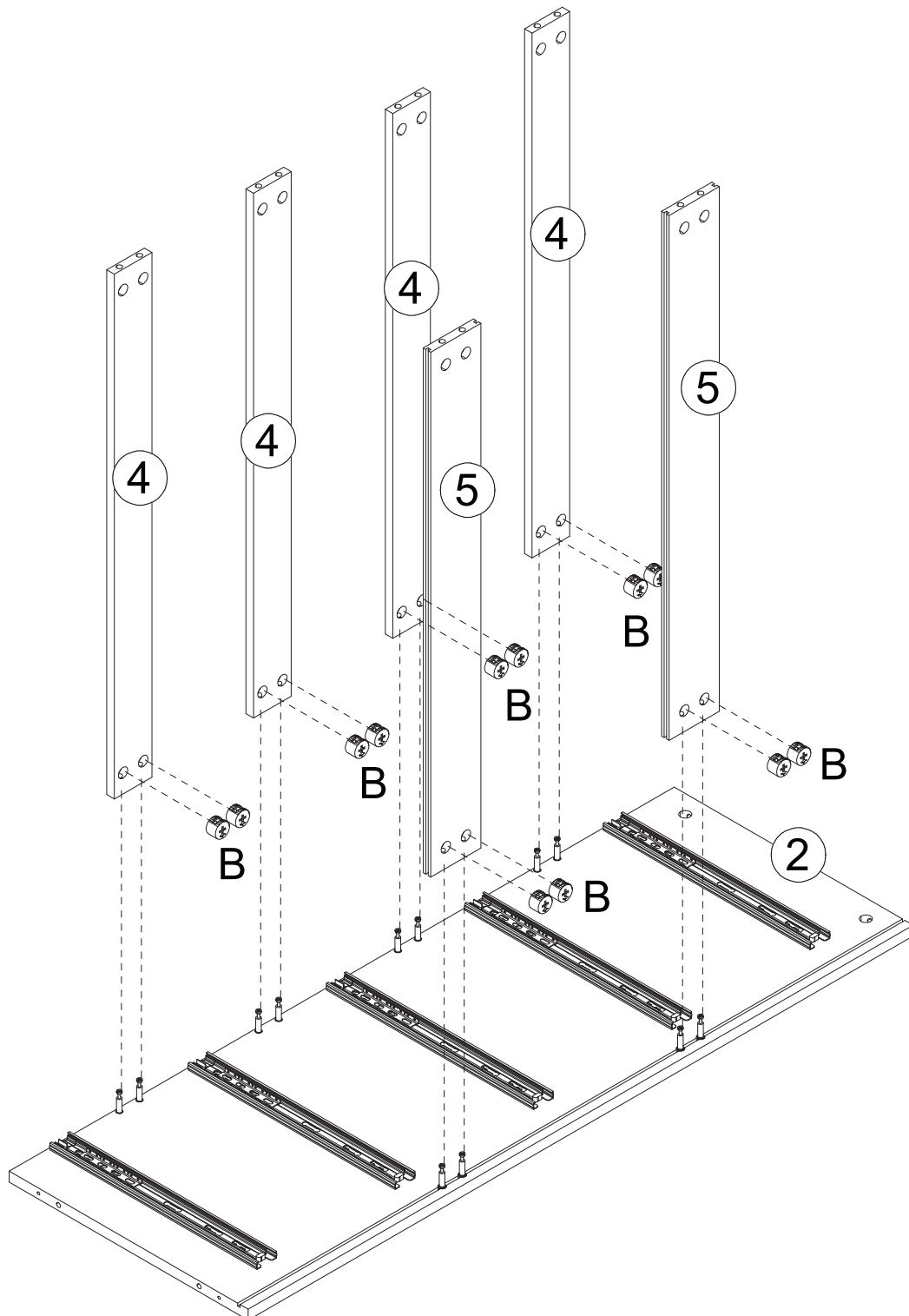

# ASSEMBLY STEPS

B x 12



## STEP 6

1. Insert panel (10) into the grooves of wood strips (5).
2. Connect panel (3) to the assembled frame (STEP 5), then tighten them with cam lock (B).

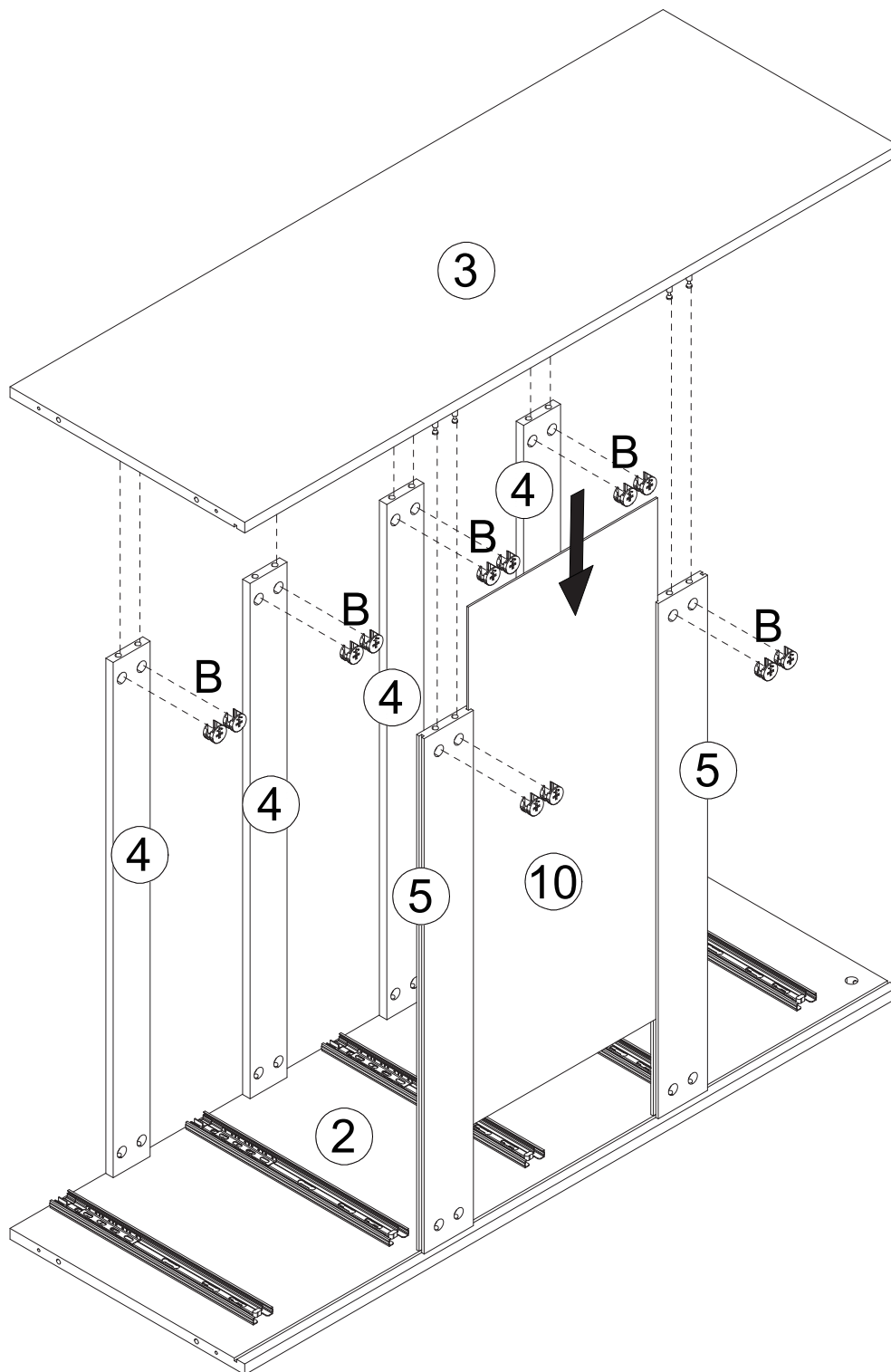

# ASSEMBLY STEPS

## STEP 7

Insert panels (9), (10) along the grooves of panels (2), (3).

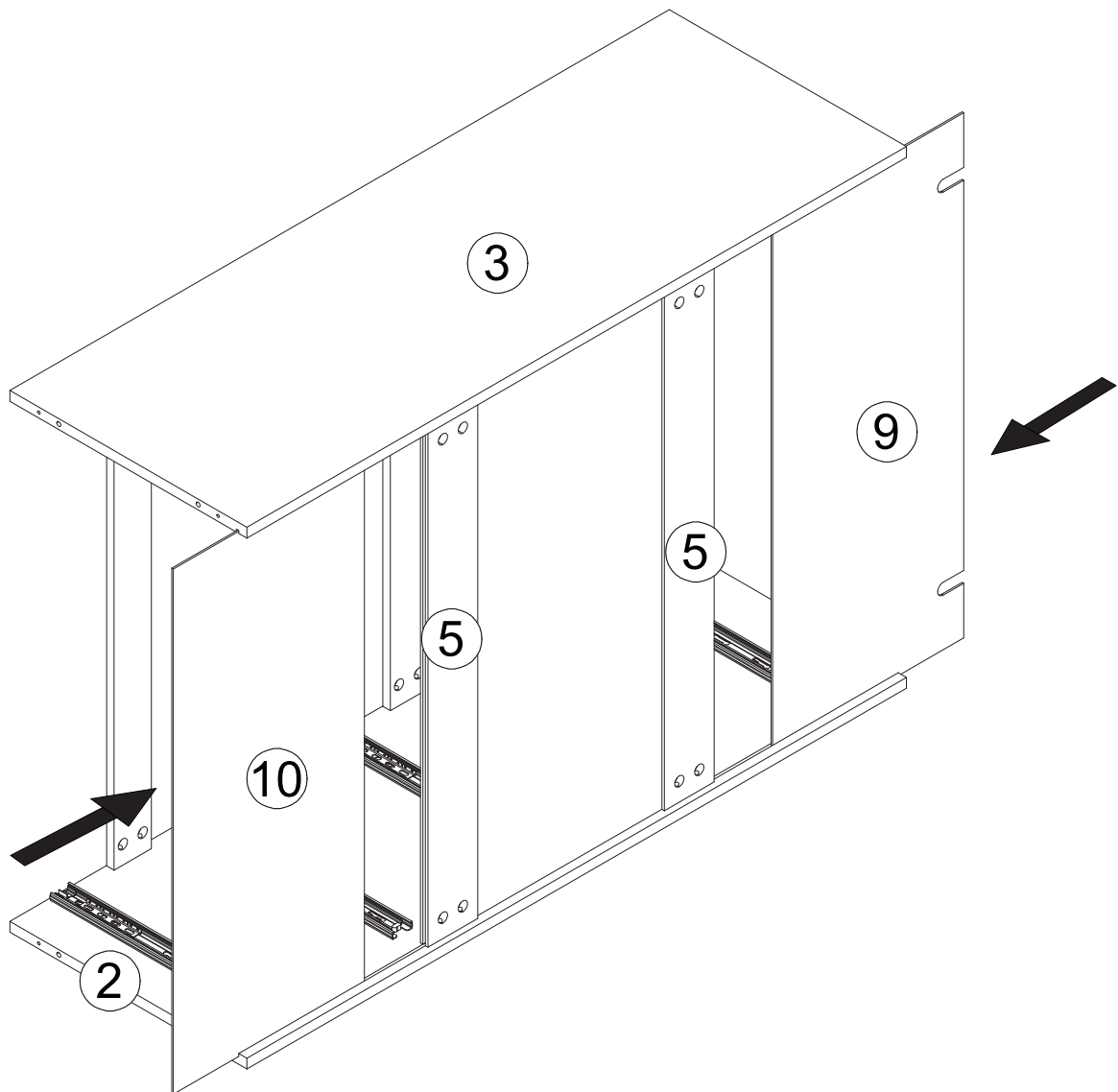

# ASSEMBLY STEPS



C x 4	$\Phi 6 \times 30 \text{mm}$ 	F x 4	$\Phi 5 \times 40 \text{mm}$ 
-------	---	-------	---

## STEP 8

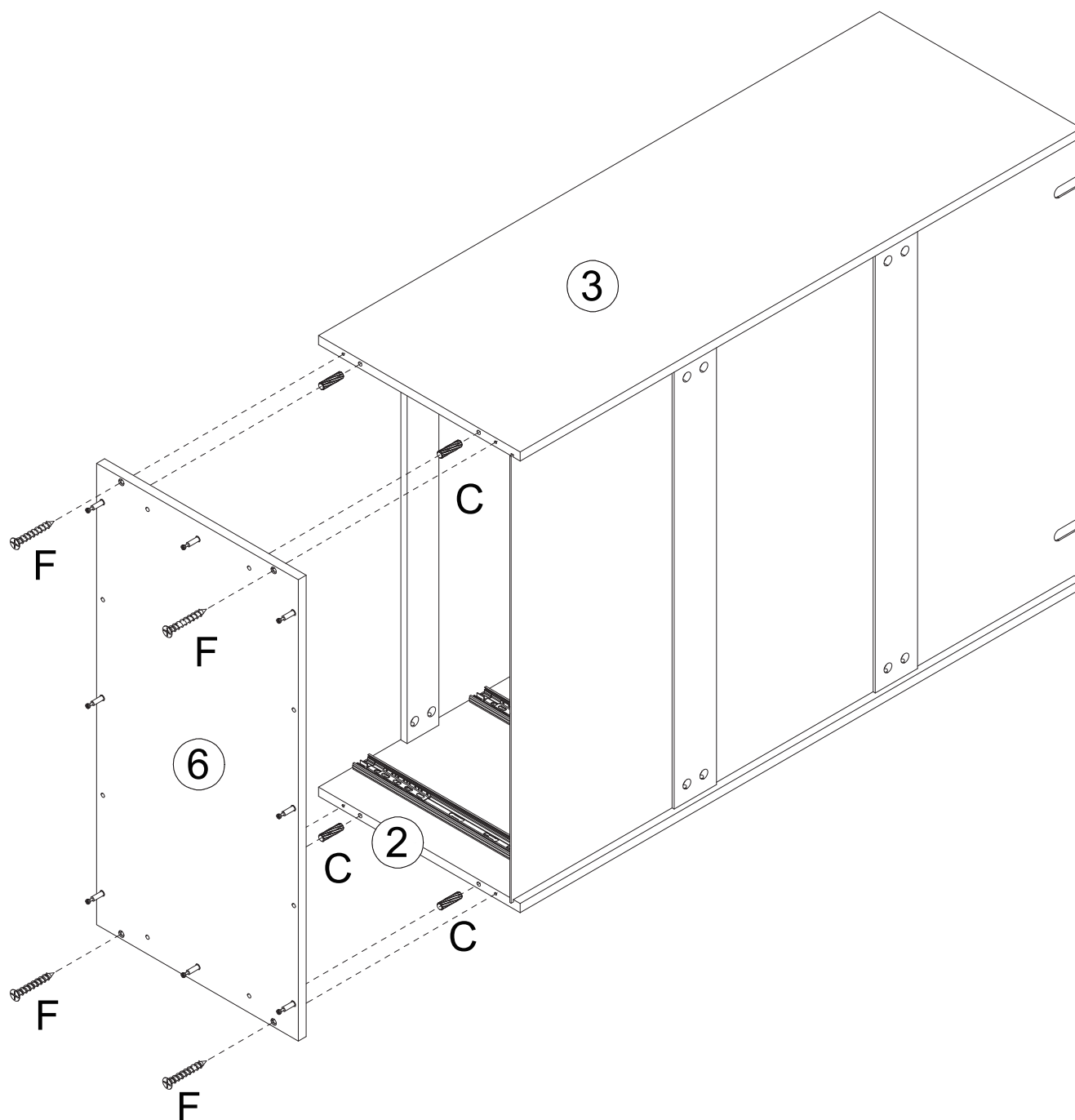
Connect the panel (6) to the assembled frame (STEP 7) with the wood dowel (C), then tighten with screw (F).

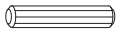

# ASSEMBLY STEPS

B x 4	 $\Phi 15 \times 10 \text{mm}$	C x 4	 $\Phi 6 \times 30 \text{mm}$	I x 4	
-------	---	-------	--	-------	--

## STEP 9

1. Connect panel (7), (8) with wood dowel (C), then tighten them with cam lock (B).
2. Stick the foot pad (I) onto the top of panel (7).

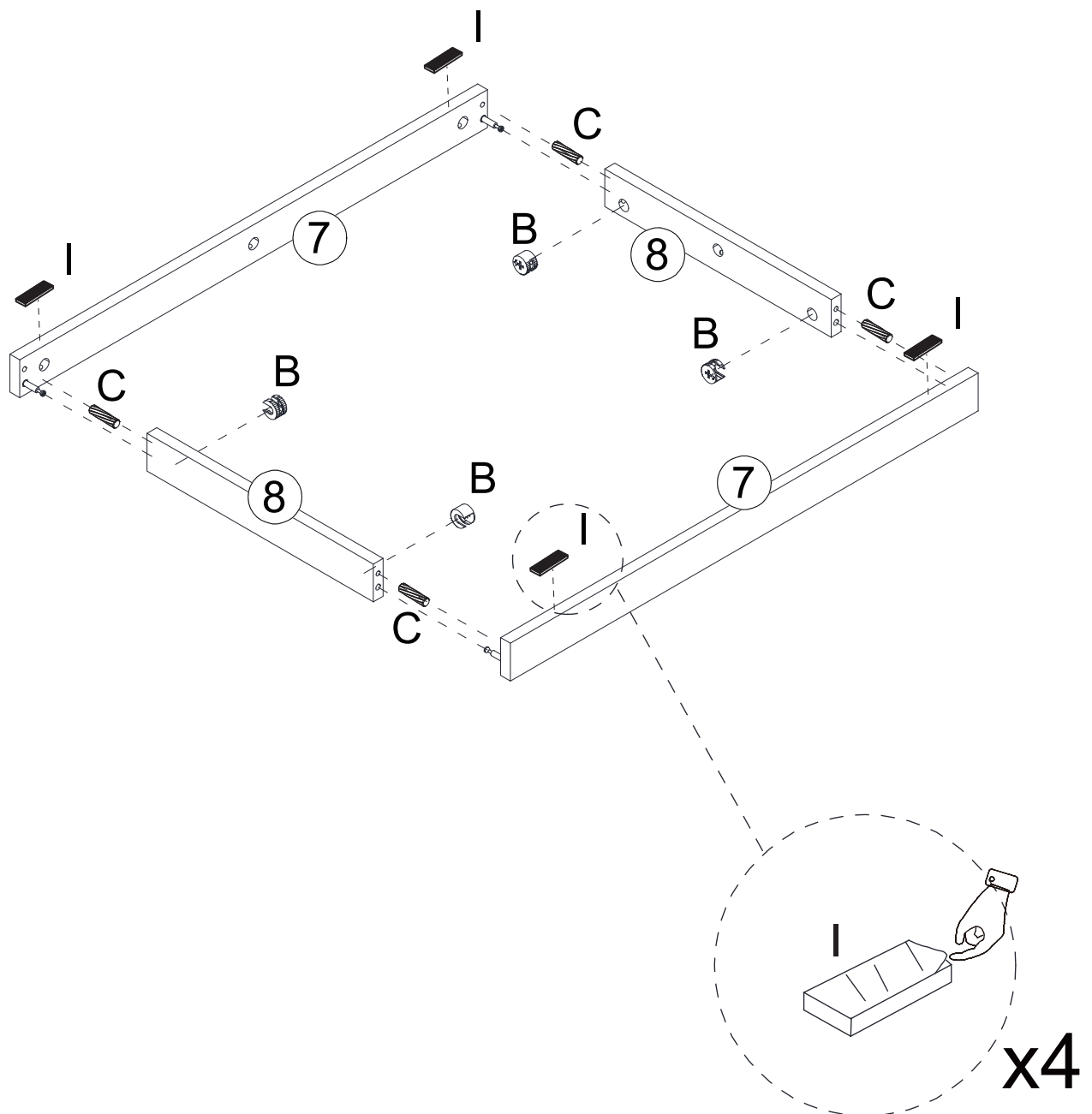

# ASSEMBLY STEPS

B x 8

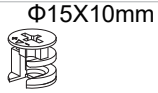

C x 8

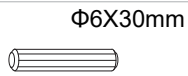

## STEP 10

Connect two assembled frames (STEP 8 & STEP 9) with the wood dowel (C), then tighten with cam lock (B).

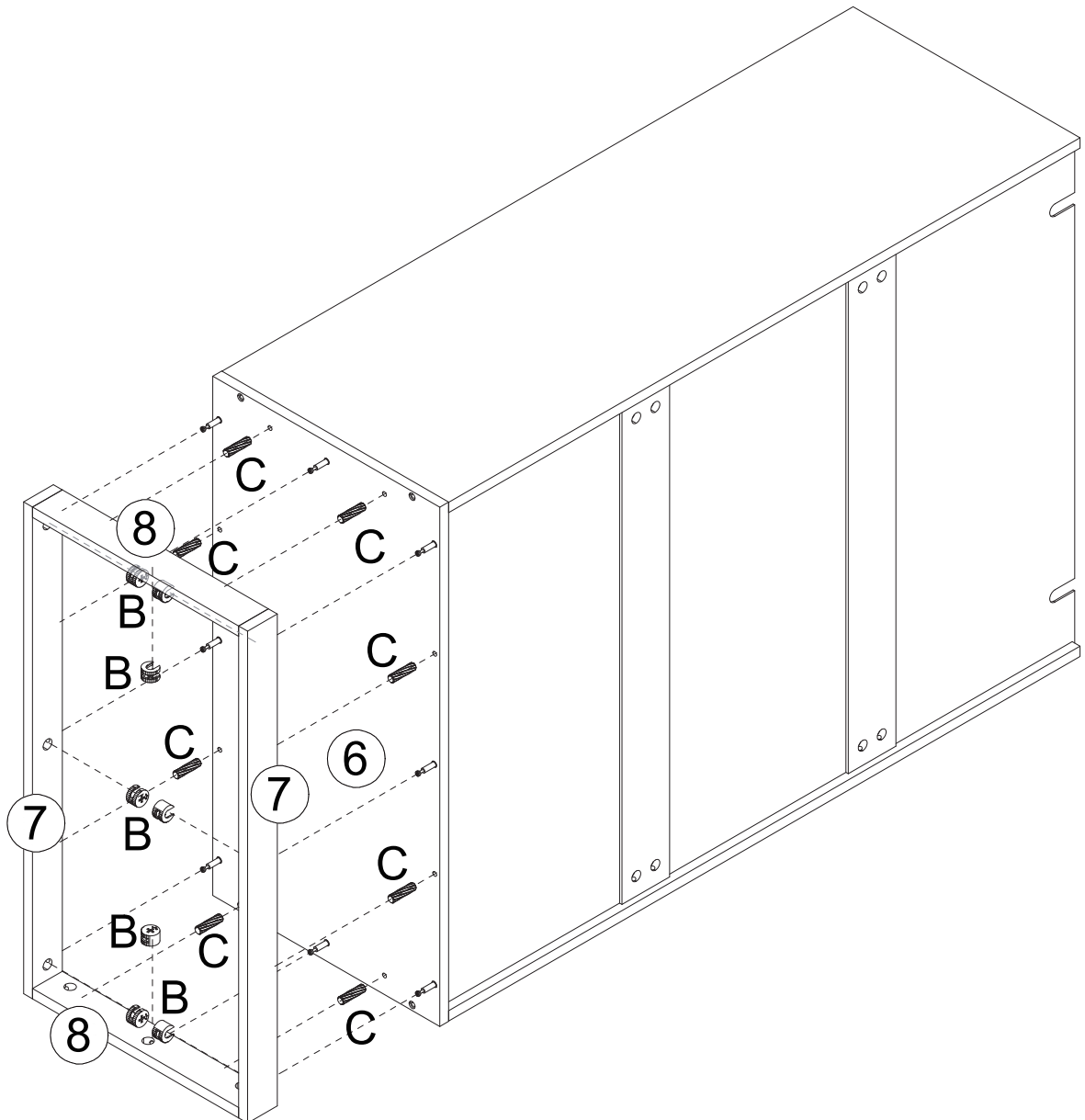

# ASSEMBLY STEPS

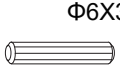
B x 4	 $\Phi 15 \times 10 \text{mm}$	C x 4	 $\Phi 6 \times 30 \text{mm}$
-------	---	-------	--

## STEP 11

Connect the panel (1) to the assembled frame (STEP 10) with the wood dowel (C), then tighten with cam lock (B).

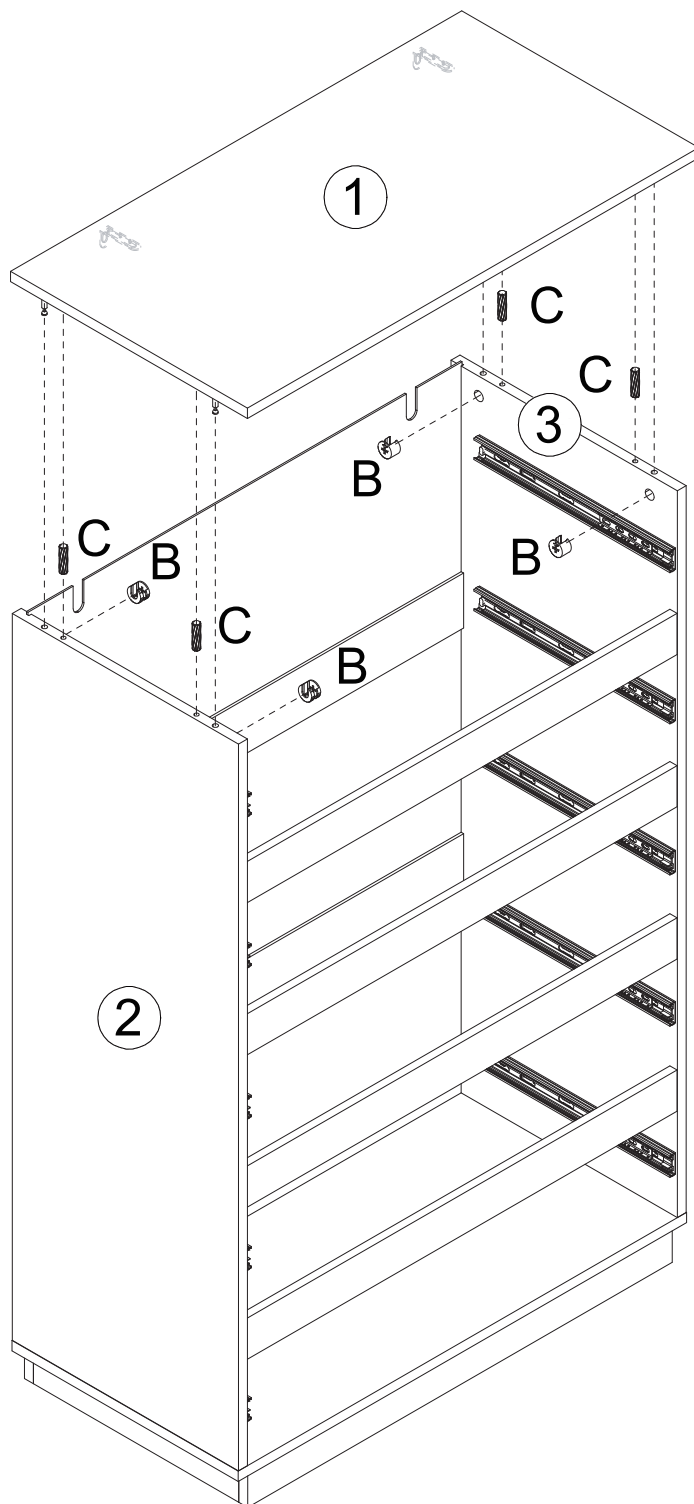

# ASSEMBLY STEPS

D x 25



## STEP 12

1. Connect panels (13), (14), (15) and wood strips (16), then tighten them with screw (D).
2. Insert panel (17) into the grooves of panels (13), (14), (15).

This step is repeated five times.

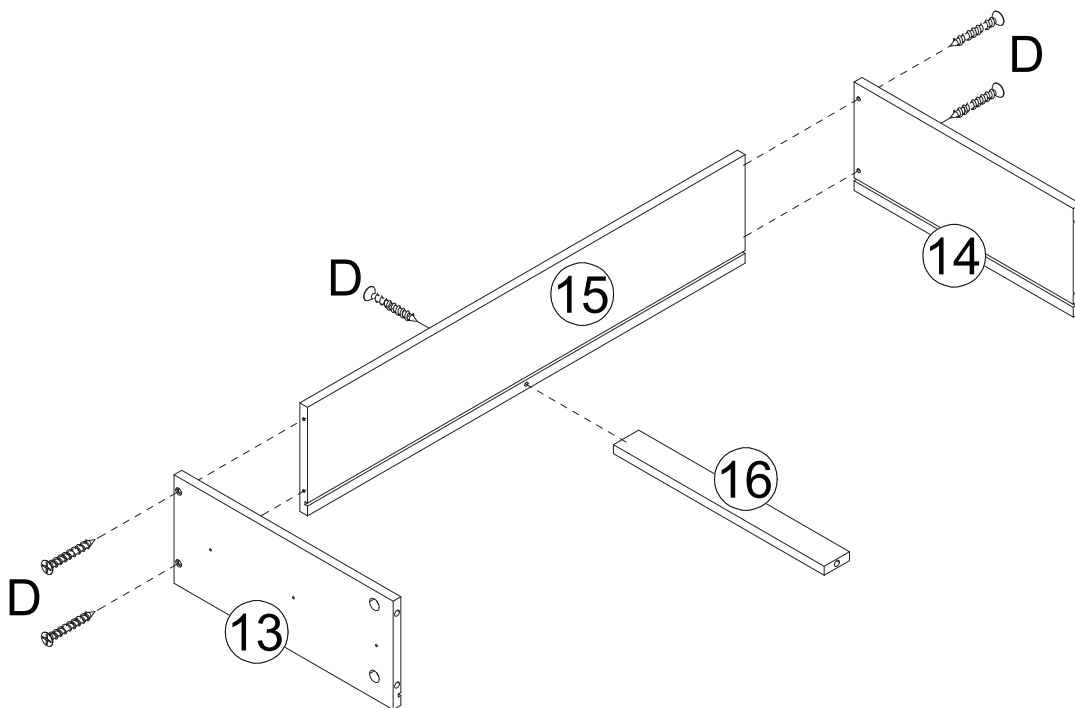

x 5

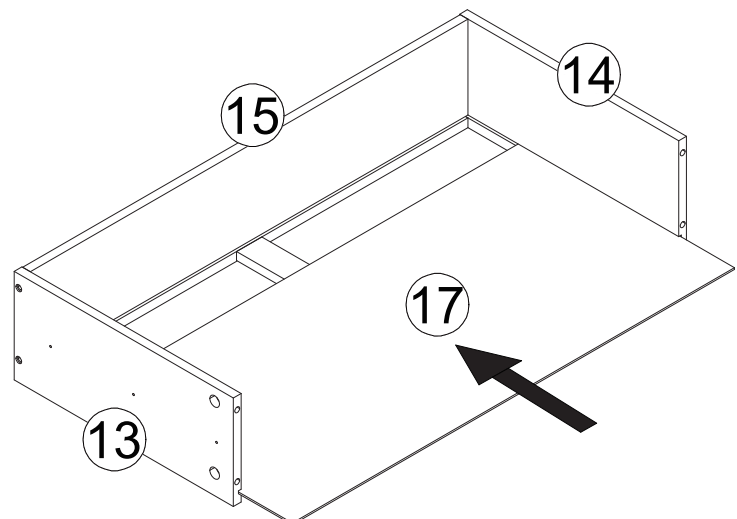

# ASSEMBLY STEPS

B x 25



## STEP 13

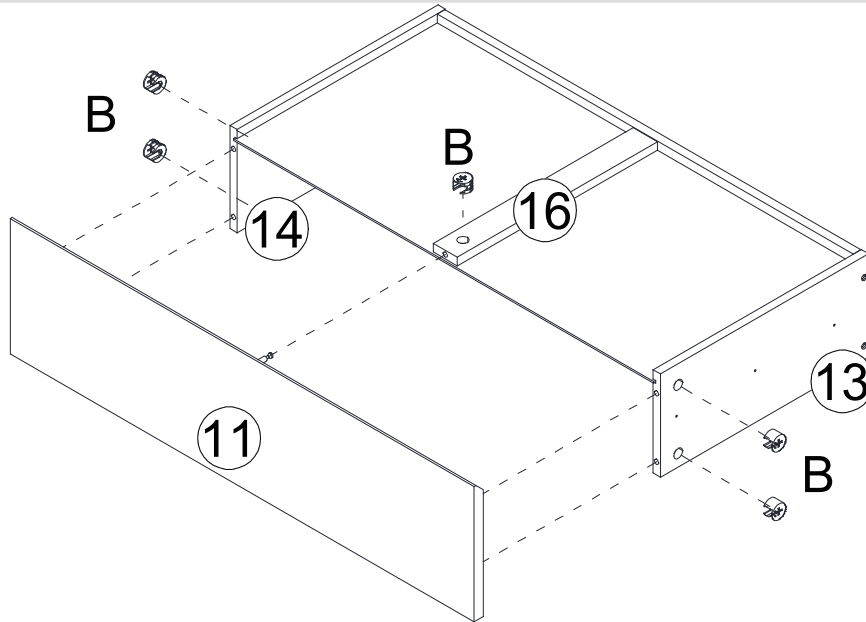

1. Connect panels (11), (13), (14) and wood strip (16), then tighten them with cam lock (B).
2. Connect panels (12), (13), (14) and wood strip (16), then tighten them with cam lock (B).

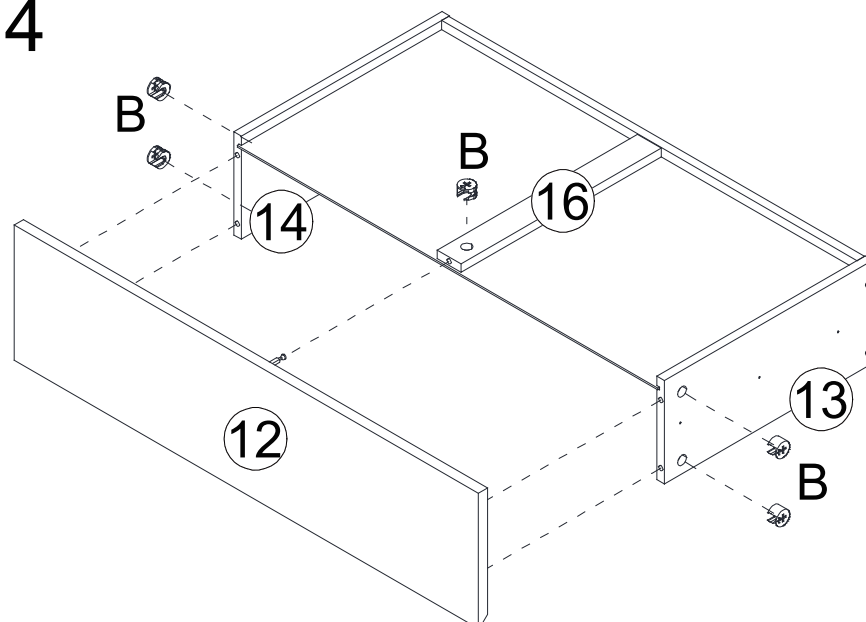

x 4



# ASSEMBLY STEPS

E x 30	$\Phi 3 \times 12 \text{mm}$ 	K x 10	K-2 
--------	---	--------	--

## STEP 14

Fix the three-section drawer slide (K-2) to the panels (13), (14) with screw (E).

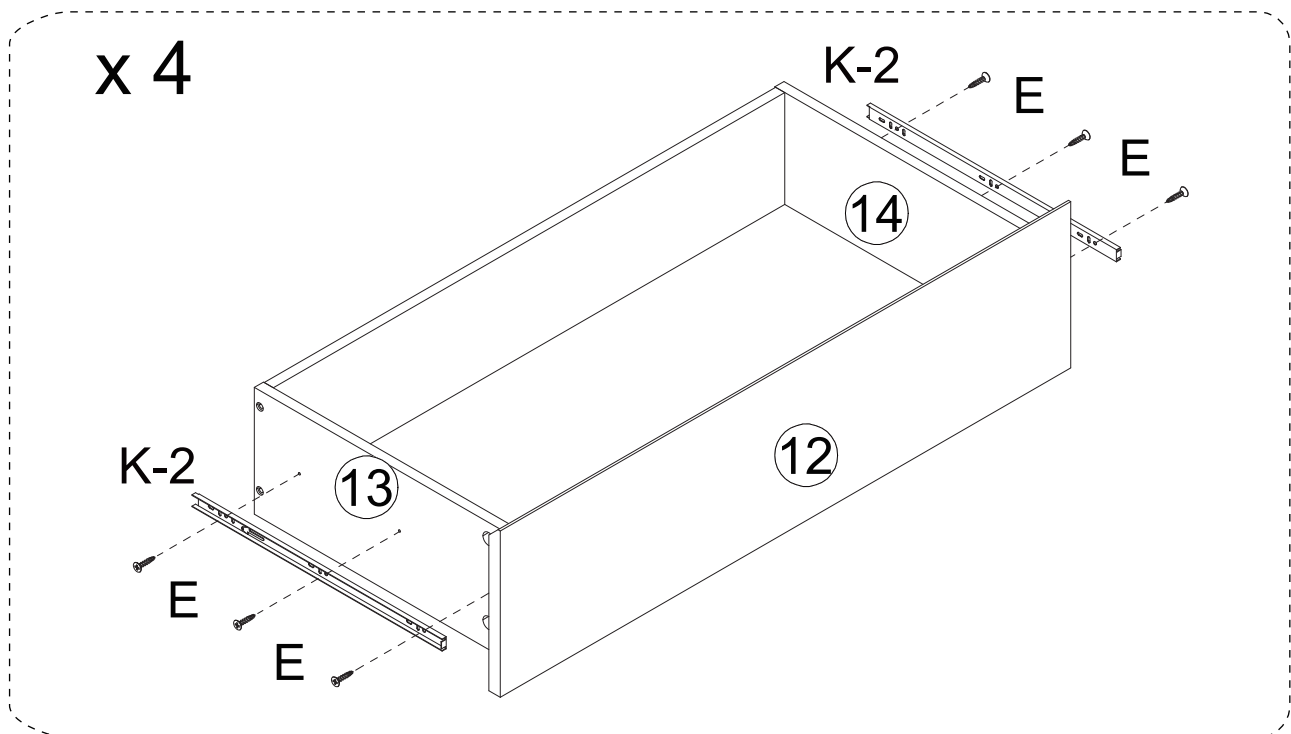
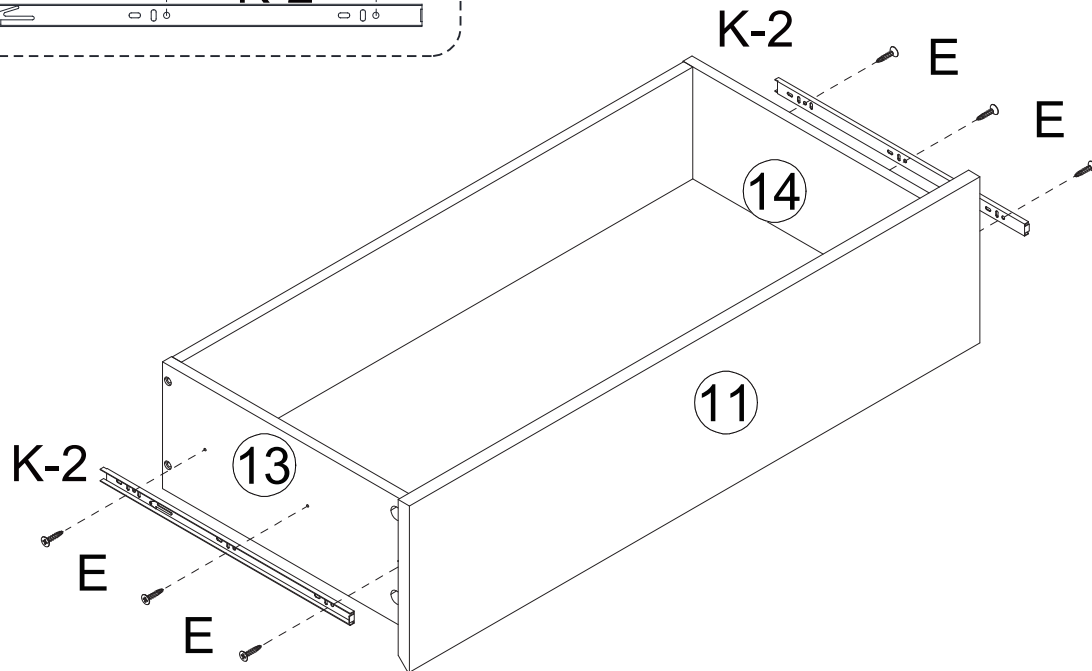
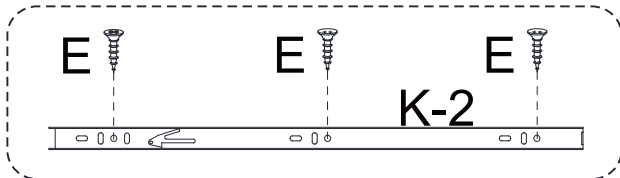

# ASSEMBLY STEPS



## STEP 15

Insert the back panel wedge (J-1) into the gap of cabinet back panel (9), (10) and tighten them with screw (J-2).

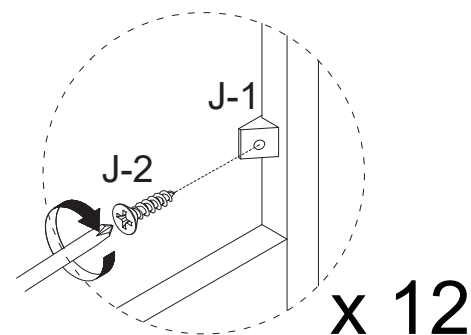
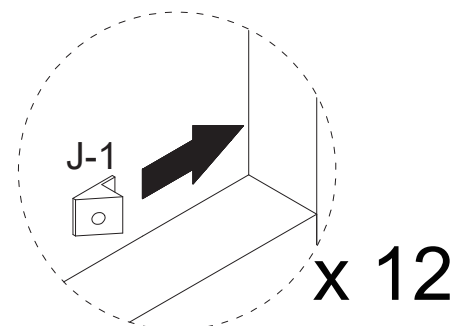
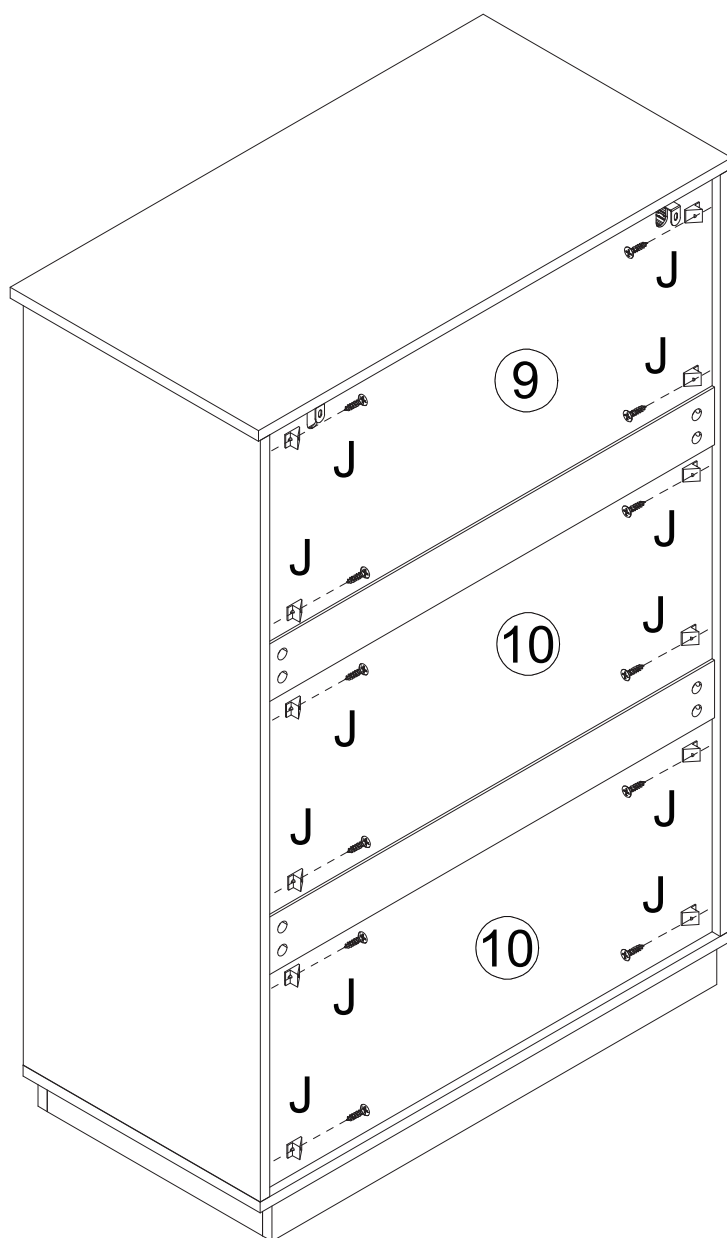

# ASSEMBLY STEPS

H x 2

H-1 

H-2 

Φ4X45mm

## STEP 16

Drill two holes in the wall, embed the plastic anchor (H-1) and then use screw (H-2) to pass through the L-shaped bracket (G-1) to fix the cabinet on the wall.

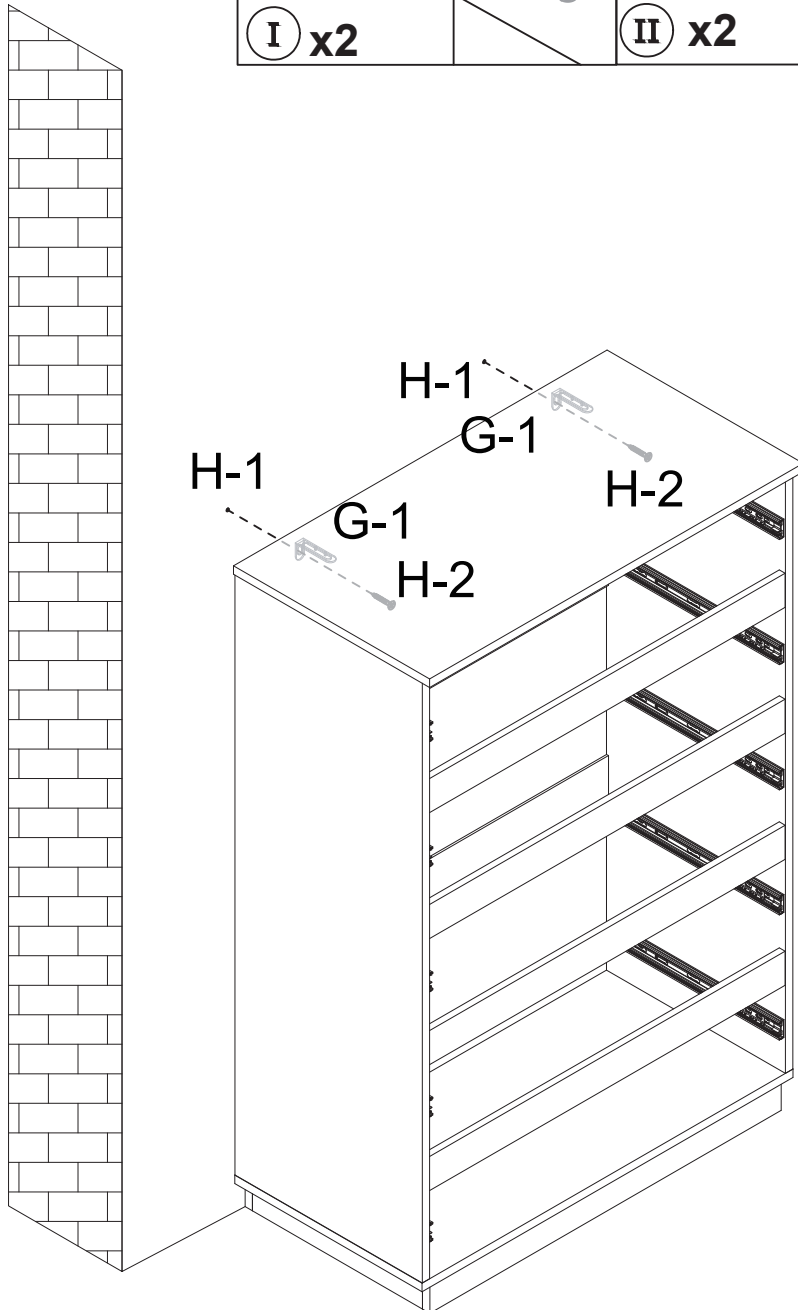
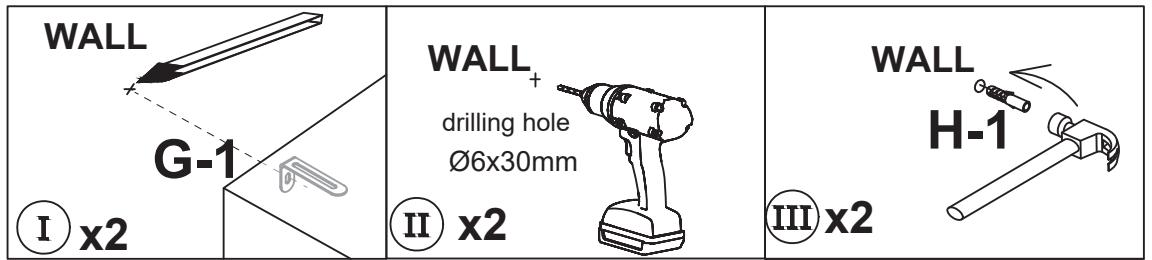

 **SCAN ME**

Please scan this QR code to access the video instructions on how to install the wall-mounting hardware

# ASSEMBLY STEPS

## STEP 17

Align the slides on the drawer and cabinet, and then gently push the drawer into the cabinet.

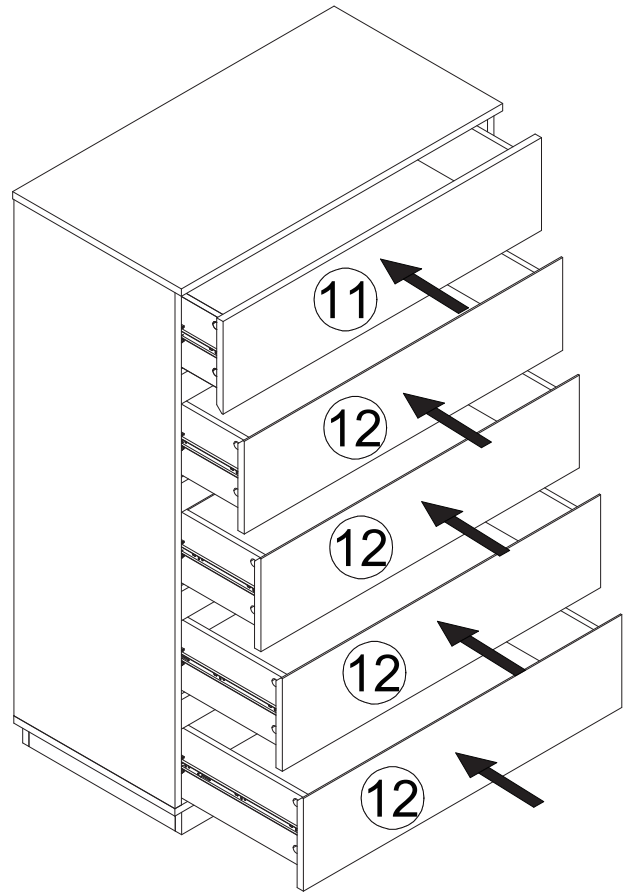
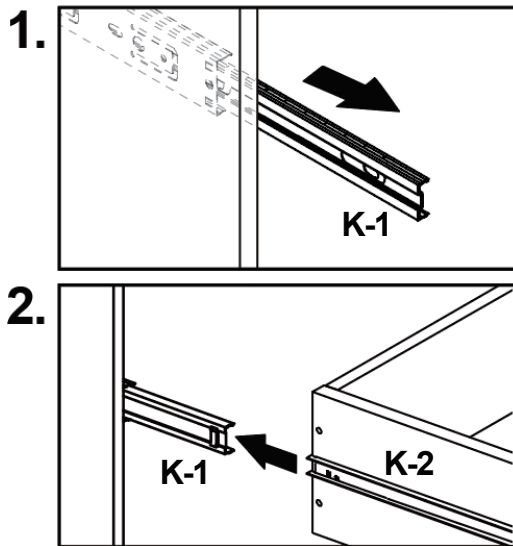

## Drawer Disassembly

If you need to remove the drawer, lift the lever on the left side slide upward and push down the lever on the right side slide, then slowly pull out the drawer.

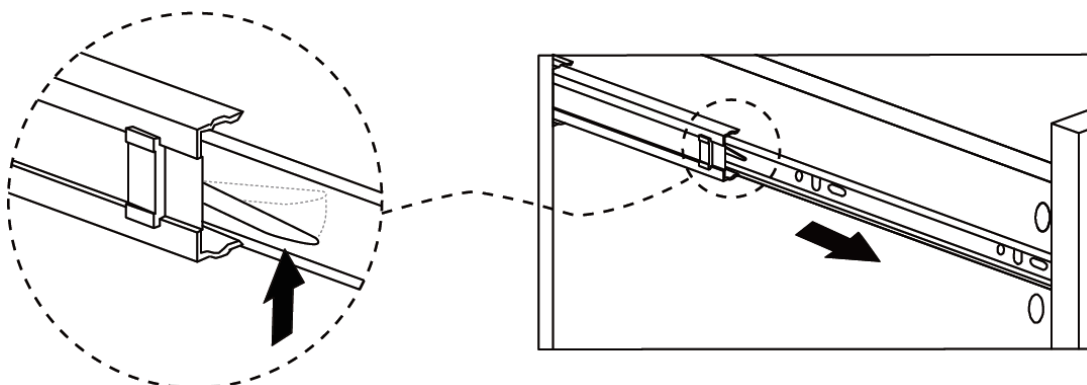

## 1. What should I do when I received a defected item?

Please feel free to contact VINGLI customer service via the link where you purchased this item with your order ID, pictures of the defective areas to us. We are eager to help you to make it right.

---

## 2. Is it easy to put the screws to the panels?

Yes. As long as you follow the instruction and use the correct screws and put it in correct holes, it is easy to screw it into pre-drilled holes.

---

## 3. What should I do if I have a problem with the drawers not closing flush?

The problem with the drawers not closing flush is usually caused by the assembly of the drawer slides. Here are the solutions as below:

1) Please check whether the slide rail is damaged, for example, the ball of the slide rail has fallen out, if so, please ask us for replacements of the drawer slides;

2) Refer to the assembly manual to check if the holes for the slide rail are assembled correctly. If there is no problem with the assembly, but the slide rail is stuck in the process of pushing in, please release the entire drawer as you did the first time you removed the drawer slides, and then push it back in again.

Any query, please contact us directly.

# Supplementary Instructions for Safe Use

## English

### **WARNING**



Children have died from furniture tipover. To reduce the risk of furniture tipover:

- ALWAYS install tipover restraint provided.
- NEVER put a TV on this product.
- NEVER allow children to stand, climb or hang on drawers, doors, or shelves.
- NEVER open more than one drawer at a time.
- Place heaviest items in the lowest drawers.
- Do not defeat or remove the drawer interlock system.

This is a permanent label.

Do not remove!

## French

### **ATTENTION**



Des enfants sont morts du basculement des meubles. Pour réduire le risque de basculement des meubles:

- TOUJOURS installer la retenue de basculement fournie.
- NE JAMAIS mettre de téléviseur sur ce produit.
- NE JAMAIS permettre aux enfants de se tenir debout, de grimper, ou de s'accrocher à des tiroirs, des portes ou des étagères.
- N'ouvrez JAMAIS plus d'un tiroir à la fois.
- Placez les objets les plus lourds dans les tiroirs les plus bas.
- Ne désactivez pas et ne retirez pas le système de verrouillage du tiroir.

Ceci est une étiquette permanente.

Ne pas enlever!

## German

### **WARNUNG**



Kinder sind an einem Möbelkipp gestorben. So verringern Sie das Risiko eines Umkippens von Möbeln:

- Installieren Sie **IMMER** die mitgelieferte Kipprückhaltevorrichtung.
- Stellen Sie **NIEMALS** einen Fernseher an dieses Produkt.
- Lassen Sie Kinder **NIEMALS** an Schubladen, Türen oder Regalen stehen klettern oder hängen.
- Öffnen Sie **NIEMALS** mehr als eine Schublade gleichzeitig.
- Legen Sie schwerste Gegenstände in die untersten Schubladen.
- Besiegen oder entfernen Sie das Schubladenverriegelungssystem nicht.

Dies ist ein dauerhaftes Etikett.

Nicht entfernen!



## **WARNING**

This product can expose you to chemicals including Formaldehyde (gas), which is known to the State of California to cause cancer. For more information go to [www.P65Warnings.ca.gov](http://www.P65Warnings.ca.gov).