

ASSEMBLY INSTRUCTIONS

EASTERN KING HEADBOARD

- A** Upper Part of Headboard **B** Middle Part of Headboard **C** Lower Part of Headboard **D** Left Side Panel **E** Right Side Panel

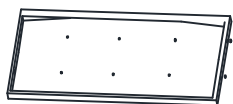

1pc



1pc

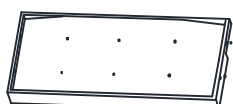

1pc

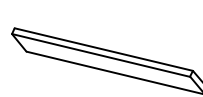

1pc

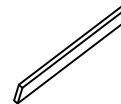

1pc

- F** Single-Sided Cover (In other carton) **G** Slat **H** Bolt 1/4" x 50 mm **I** Lock Washer 1/4" **J** Flat Washer 1/4"



1pc



3 pcs



30 pcs



30 pcs



30 pcs

- K** Allen Wrench 1/4"



1pc

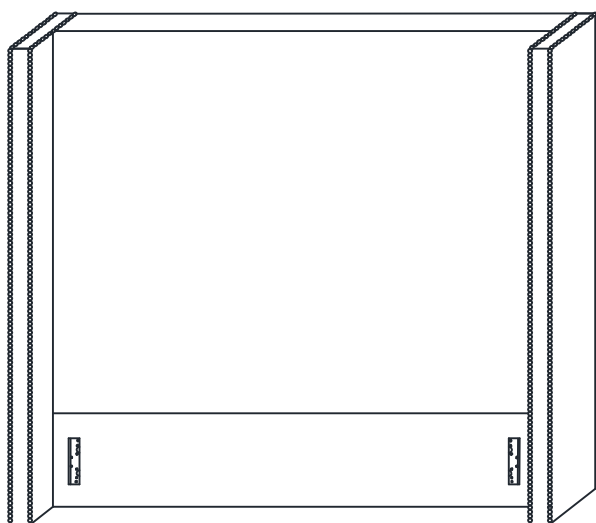

This page lists all the contents included in the box. Please take the time to identify the hardware as well as the individual components to this product. As you unpack and prepare for assembly, place the contents on a carpeted or padded area to protect them from damage.

Notice: This product requires more than two people for assembly.

- 1 Attach Slat (G) to Upper & Middle & Lower Part of Headboard (A, B, C) using Bolt (H), Lock Washer (I) and Flat Washer (J) with Allen Wrench (K).

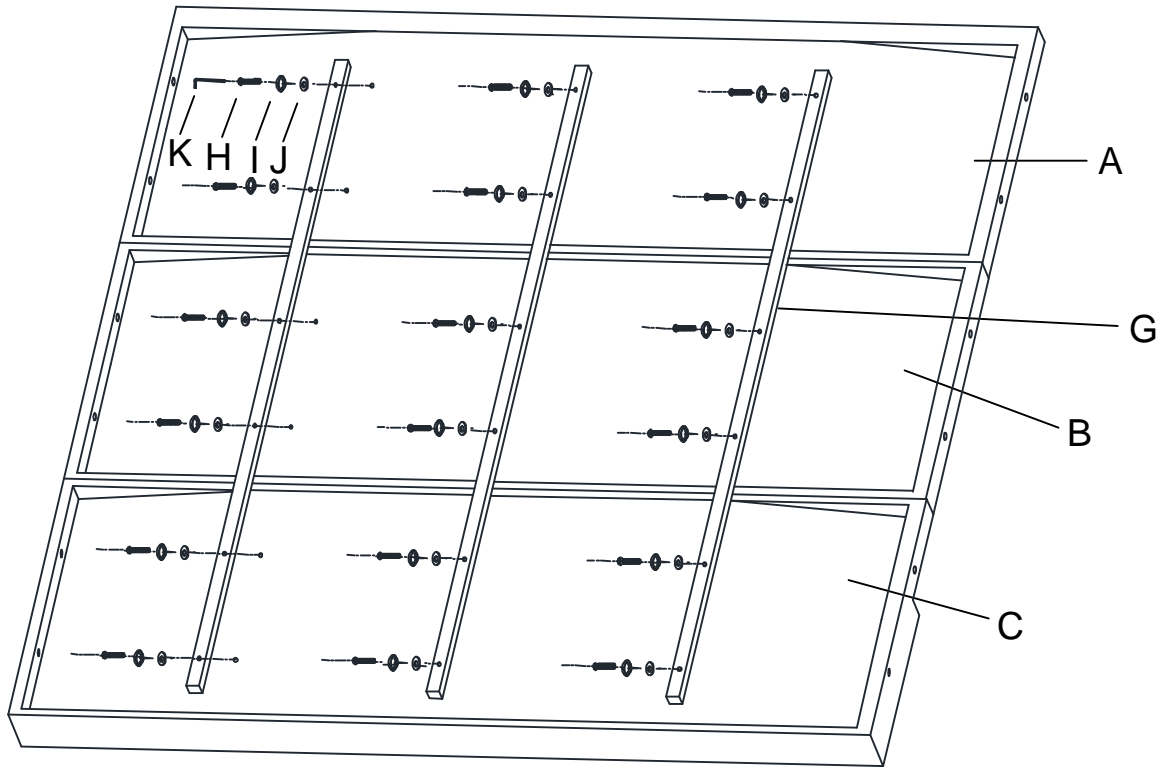

- 2 Place Single-Sided Cover (F) on the front of Headboard (A, B, C), then attach the Velcro at the back of Headboard (A, B, C).

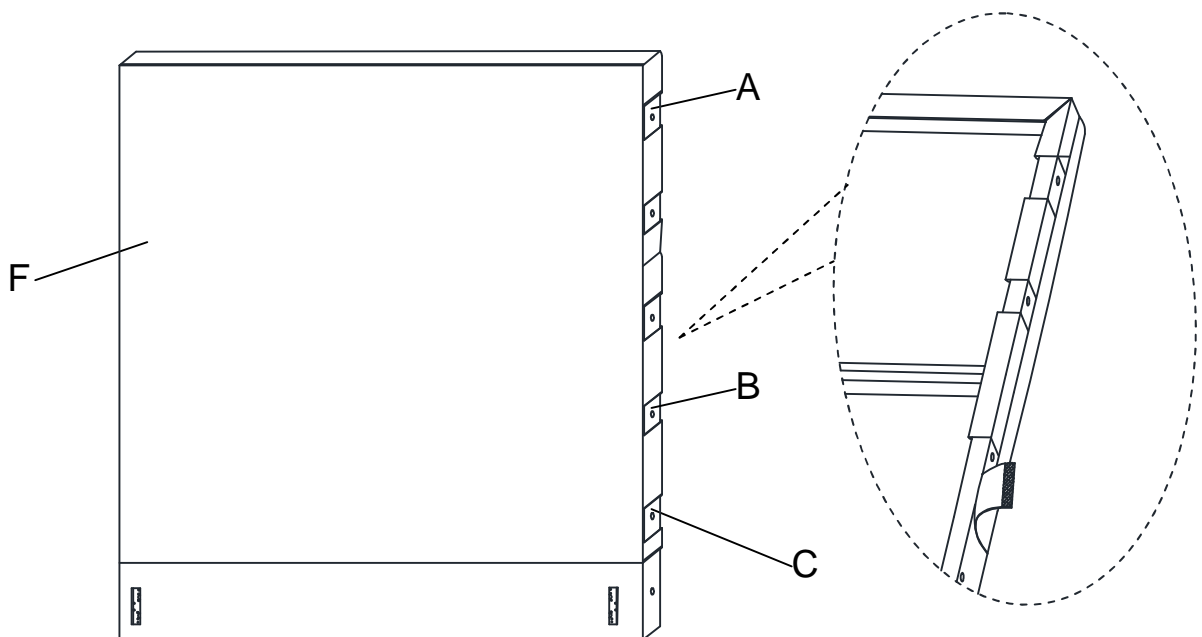

-
- 3** Attach Left & Right Side Panel (D & E) to Headboard (A, B, C) using Bolt (H), Lock Washer (I) and Flat Washer (J) with Allen Wrench (K).

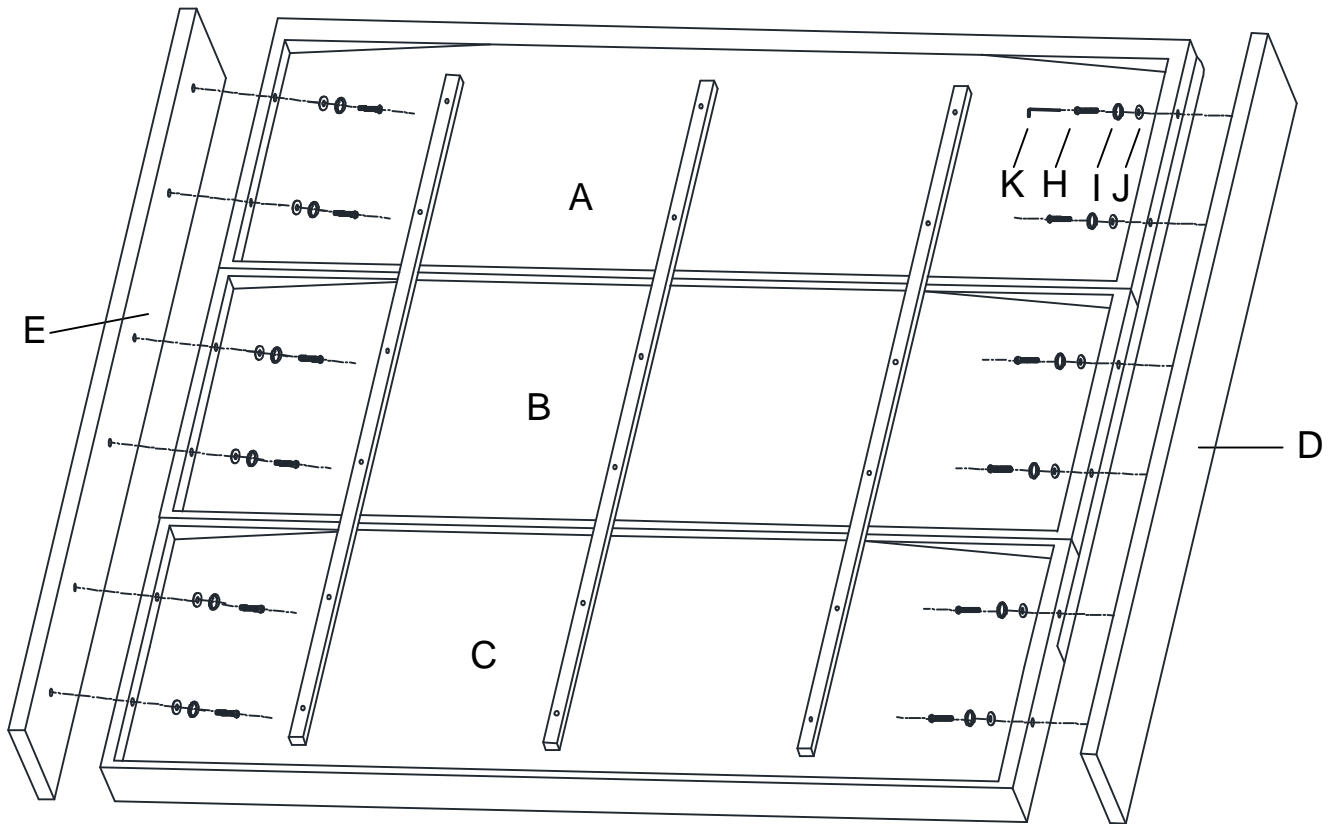

Helpful Tip:

- After assembly, if fabric is not smooth or wrinkled, please iron it.

Cleaning & Care

Treat surfaces with care. Surfaces are resistant to scratches but are not scratch resistant. Clean surfaces with a dry or damp soft cloth. Do not use abrasive cleaners. Hardware may loosen over time. Periodically check that all connections are tight.

ASSEMBLY INSTRUCTION

WINGBACK KING BED WITH REGULAR SLATS

A Footboard



1 pc

B Side Rails

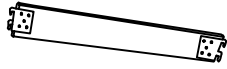

2 pcs

C Wooden Leg

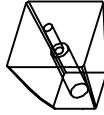

2 pcs

D Support Leg



15 pcs

E Wooden Slat

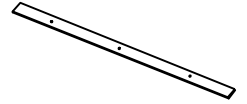

5 pcs

F Screw



20 pcs

G Bolt
1/4" x 75mm



2 pcs

H Bolt
1/4" x 50mm



15 pcs

I Flat Washer



17 pcs

J Lock Washer



17 pcs

K Allen Wrench



1 pc

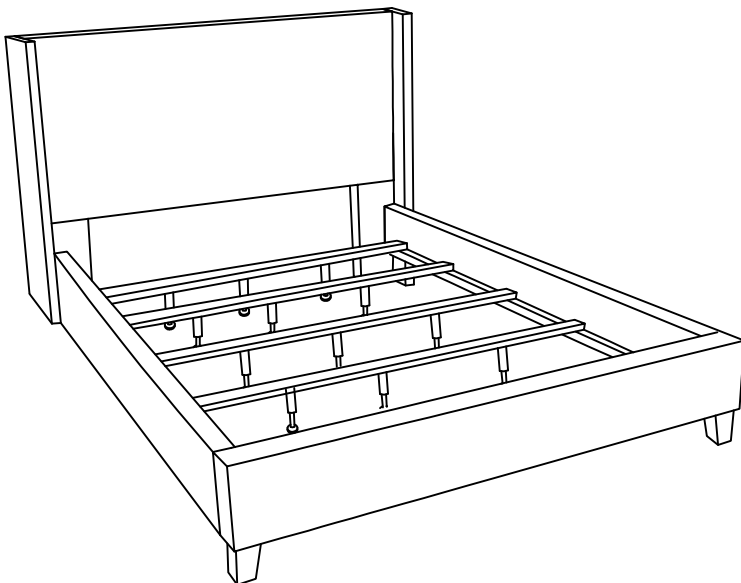

This page lists all the contents included in the box. Please take the time to identify the hardware as well as the individual components to this product. As you unpack and prepare for assembly, place the contents on a carpeted or padded area to protect them from damage.

- 1** Attached Wooden Leg (C) to the Footboard (A) use Bolt (G), Lock Washer (J) and Flat Washer (I) on both of holes. Turn the Allen Wrench (K) in Bolt (G).

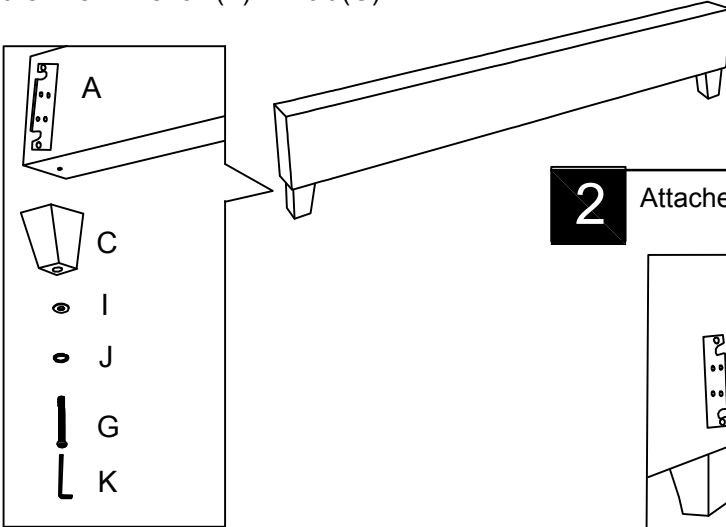

- 2** Attached Side Rail (B) to the Headboard and Footboard (A).

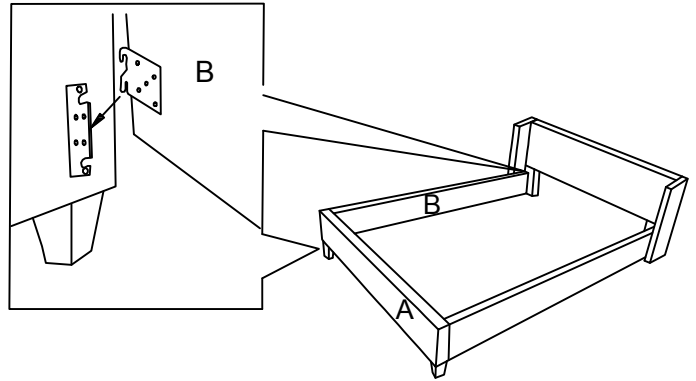

- 3** Assembly Wooden Slats (E) and Support Leg (D) use Flat Washer (I), Lock Washer (J) and Bolt (H), Turn the Allen Wrench (K) in Bolt (H).

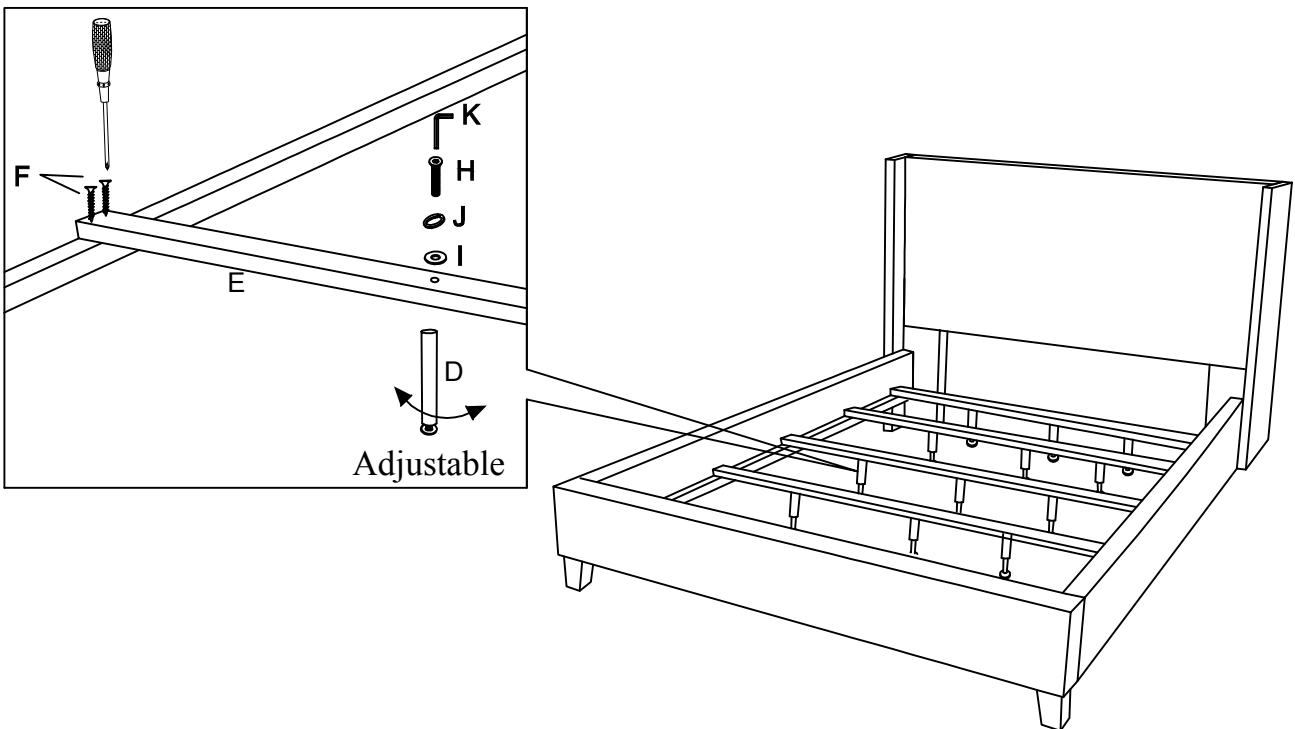

Cleaning & Care

Treat surface with care. Surface is resistant to scratches but is not scratch resistant. Clean surfaces with a dry or damp soft cloth. Do not use abrasive cleaners. Hardware may loosen over time. Periodically check that all connections are tight.