

ASSEMBLY INSTRUCTION

We believe you will absolutely love your new furniture. Please immediately examine this product carefully. Any request for missing part or damage replacement must be received within 90 days of your receipt of the product. For some reason you want to return the product, please contact us directly before you decide to return your product to the retailer. Our Customer Service team can answer most concerns and can assist you with any questions you may have about your new product.

Have these ready when you email:

- Item Number**
- PO #**
- Purchaser Name**
- Proof of Purchase**

- Description of the problem and/or the Part Number needed**

Replacements for missing or damaged parts or hardware are normally shipped within 3 to 5 business days and we thank you for your patient.

The item must be returned in good condition, in original box, with all original proof of purchase, parts and accessories, within the time frame specified by the retailer it was purchased from.

90-Day Limited Warranty Statement for Manufacturing Defects

Please read this Limited Warranty carefully. To maintain your Warranty, you will need to comply with the conditions stated here.

This warranty is for manufacturing defects only and does not cover damages as a result of misuse.

1. Our products sold comply with the description contained in this Warranty. All parts and products are warranted 90-Day from the original date of delivery except: parts and products used for commercial, contract, rental trade, institutional, or any other non-residential purposes; parts and products that have not been maintained in accordance with the care recommendations provided; parts and products damaged resulting from the consumer's improper assembly; or parts and products that are damaged or defective due to normal wear and tear.





2. To exercise rights under this warranty, proper documentation, i.e., photography, purchase order number, manufacturer's bar code label, and or any other pertinent information upon request is required. We reserve the right to repair or replace the product within the warranty period based upon the documentation received as support of a claim for consideration. We will not replace or repair any product if improper maintenance, improper handling, or improper use caused the damage. Any product sold from or modified by a Non-Authorized Dealer, Seller or Consumer will void the Warranty.

3. Cost of packaging and shipping to and from us is not covered by the warranty unless expressly arranged by us. This warranty does not extend to furniture that has been exchanged or replaced by us as settlement of an original claim of defective merchandise. This warranty does not extend to furniture that has been moved from delivery location on original purchase order.

We appreciate your business!

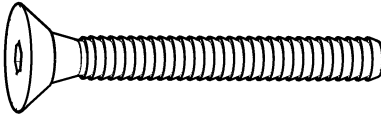
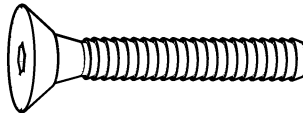
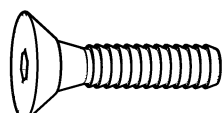
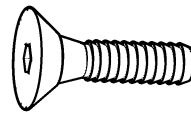
ASSEMBLY INSTRUCTION

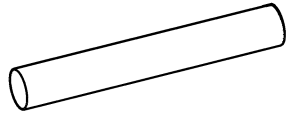
HARDWARES LIST

ITEM	DESCRIPTION	DRAWING	QTY
A	JCBC SCREW M6 x 90 MM		38 PCS
B	JCBC SCREW M6 x 50 MM		22 PCS
C	JCBC SCREW M6 x 30 MM		6 PCS
D	JCBC SCREW M6 x 25 MM		12 PCS
E	BARREL NUT M6 x 13 MM		44 PCS
F	WOOD DOWEL 10 x 40 MM		46 PCS
G	METAL DOWER 10 X 100 MM		4 PCS
H	CSK SCREW M4 x 25 MM		16 PCS
I	M4 ALLEN KEY		1 PC

ASSEMBLY TOOLS REQUIRED

1. SCREWDRIVER (NOT PROVIDE)

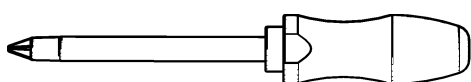

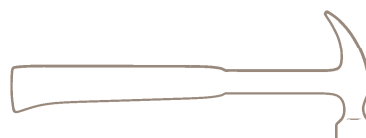

2. HAMMER (NOT PROVIDE)





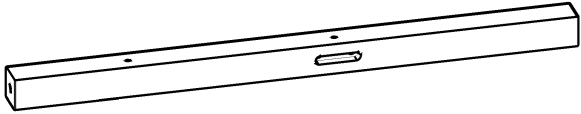
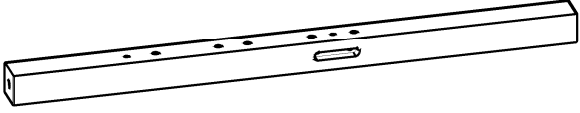
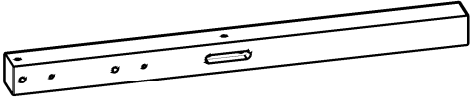
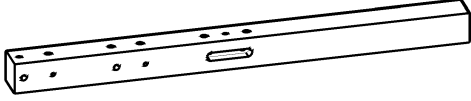

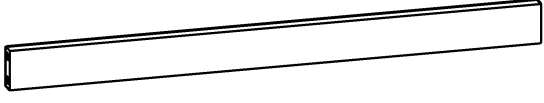
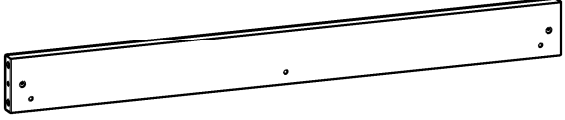
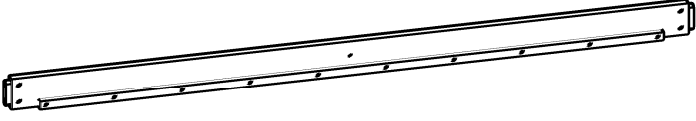
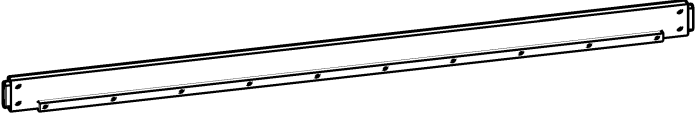
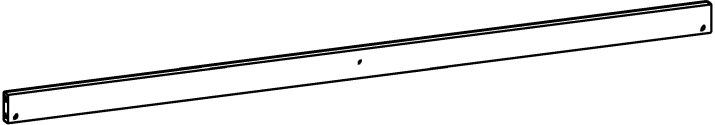
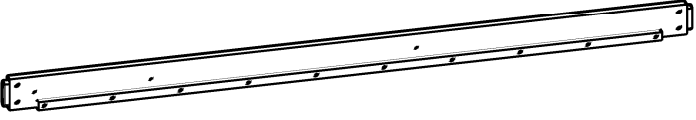
ASSEMBLY INSTRUCTION

PARTS LIST

ITEM	DESCRIPTION	DRAWING	QTY
1	BOTTOM POST (i)		2 PCS
2	BOTTOM POST (ii)		2 PCS
3	TOP POST (i)		2 PCS
4	TOP POST (ii)		2 PCS
5	CROSS (i)		4 PCS
6	CROSS (ii)		4 PCS
7	CROSS (iii)		4 PCS
8	TOP BACK SIDE RAIL		1 PC
9	BOTTOM BACK SIDE RAIL		1 PC
10	LONG GUARDRAIL		2 PCS
11	TOP FRONT SIDE RAIL		1 PC

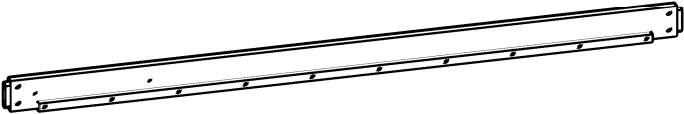
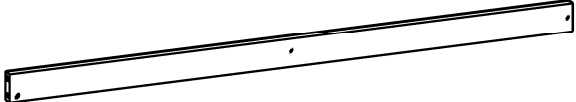
ASSEMBLY INSTRUCTION

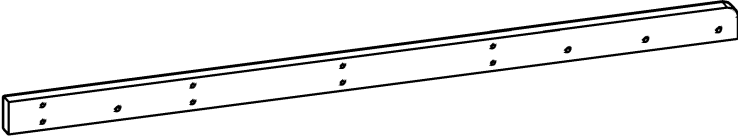
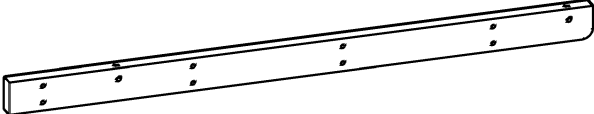
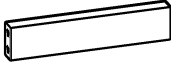
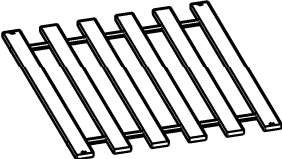
PARTS LIST

ITEM	DESCRIPTION	DRAWING	QTY
12	BOTTOM FRONT SIDE RAIL		1 PC
13	SHORT GUARDRAIL		2 PCS
14	SAFETY RAIL CLEAT		2 PCS
15	LADDER LONG		1 PC
16	LADDER SHORT		1 PC
17	LADDER STEP		4 PCS
18	SLAT		4 SET
19	WOODEN SUPPORT		4 PCS

ASSEMBLY INSTRUCTION

IMPORTANT NOTICE

- Use only Mattresses - 74" - 75" long and 37 1/2" - 38 1/2" wide on the upper bunk.
- Use only Mattresses - 74" - 75" long and 38" - 38 1/2" wide on the lower bunk.
- Ensure thickness of mattresses does not exceed 7" and mattresses is at least 5" below upper edge of guardrails.
- Check that you have all parts and hardware before assembly. Parts apparently missing are often found in the packing materials.
- Replacement parts, including additional guardrails, may be obtained from any of retailers purchased from.

SAFETY WARNING

- Follow the information on the warnings appearing on the upper bunk end structure and on the carton. Do not remove warning label from bed.
- Always use the recommended size mattresses or mattress support, or both, to help prevent the likelihood of entrapment or falls.
- Surface of mattress must be at least 5 in. (127 mm) below the upper edge of guardrails.
- Do not allow children under 6 years of age to use the upper bunk.
- Periodically check and ensure that the guardrail, ladder, and other components are in their proper position, free from damage, and that all connectors are tight.
- Do not allow horseplay on or under the bed and prohibit jumping on the bed.
- Always use ladder for entering and leaving upper bunk.
- Do not use substitute parts. Contact the retailer or dealer for replacement parts.
- Use of a night light may provide added safety precaution for a child using the upper bunk.
- Always use guardrails on both long sides of the upper bunk. If the bunk bed will be placed next to the wall, the guardrail that runs the full length of the bed should be placed against the wall to prevent entrapment between the bed and wall.
- The use of water or sleep flotation mattresses is prohibited.

STRANGULATION HAZARD :

- Do not attach or hang items to any part of the bunk bed that are not designed for use with the bed; for example, but not limited to, hooks, belts, and jump ropes.
Keep these instructions for future reference.

PROHIBIT MORE THAN ONE PERSON ON UPPER BUNK.

ASSEMBLY INSTRUCTION

PARTS LOCATION

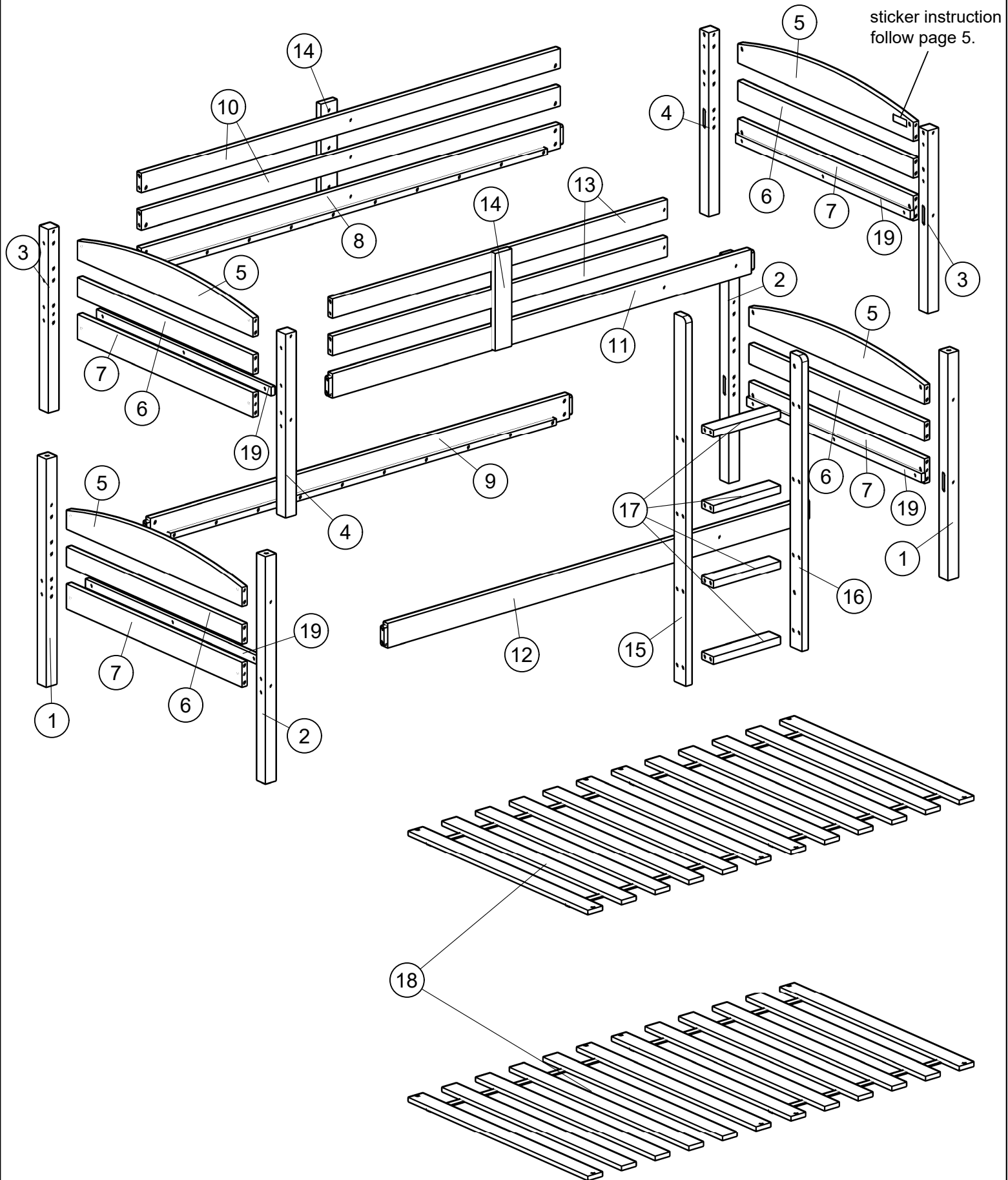

ASSEMBLY INSTRUCTION

STEP 1

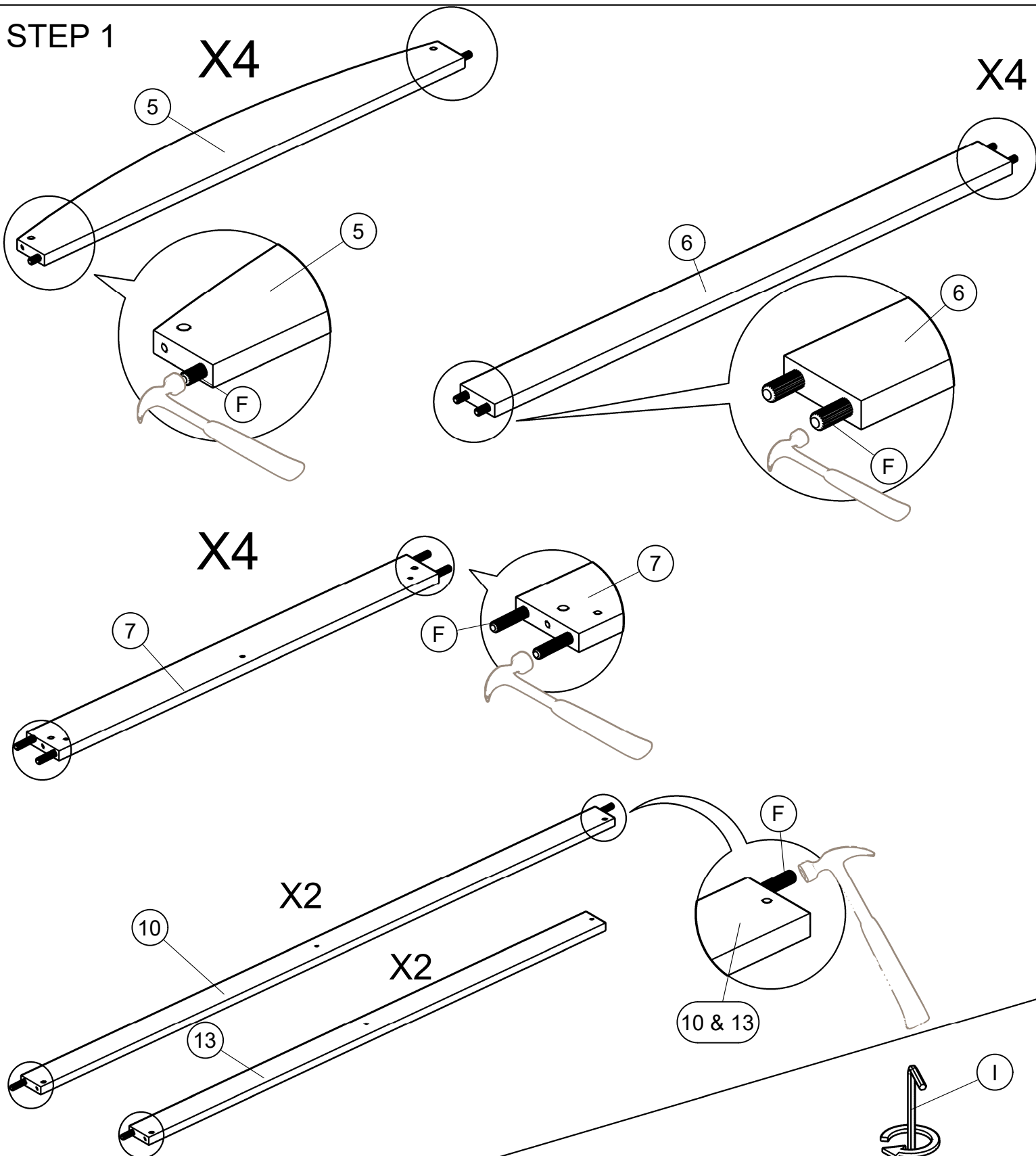

STEP 2

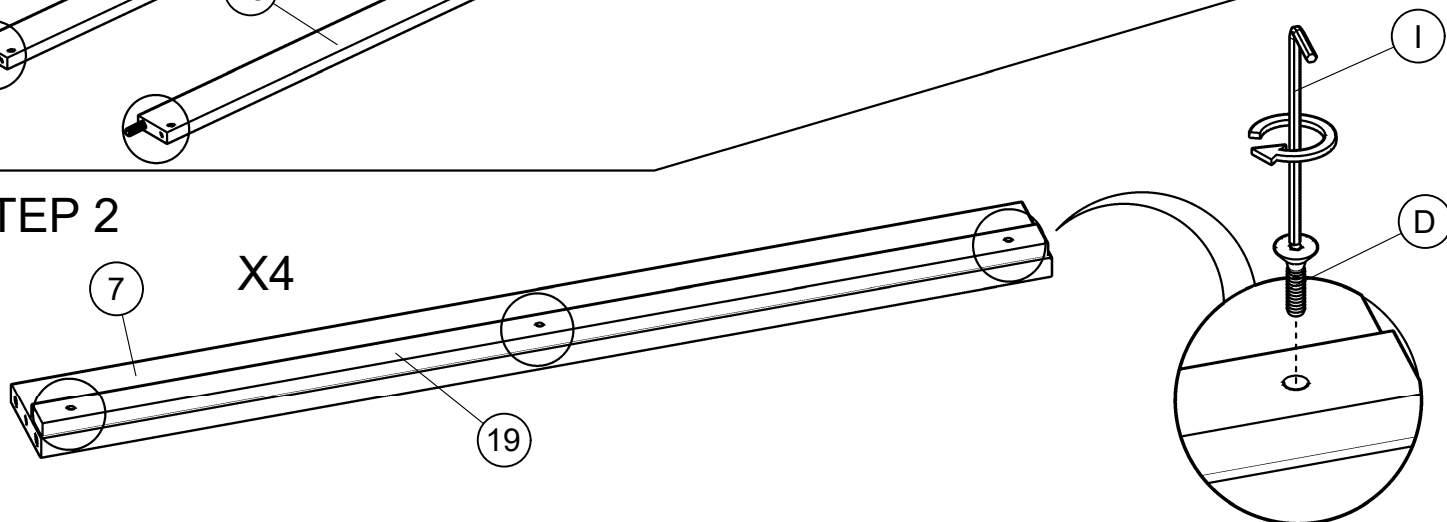

ASSEMBLY INSTRUCTION

STEP 3

X2

STEP 3.1

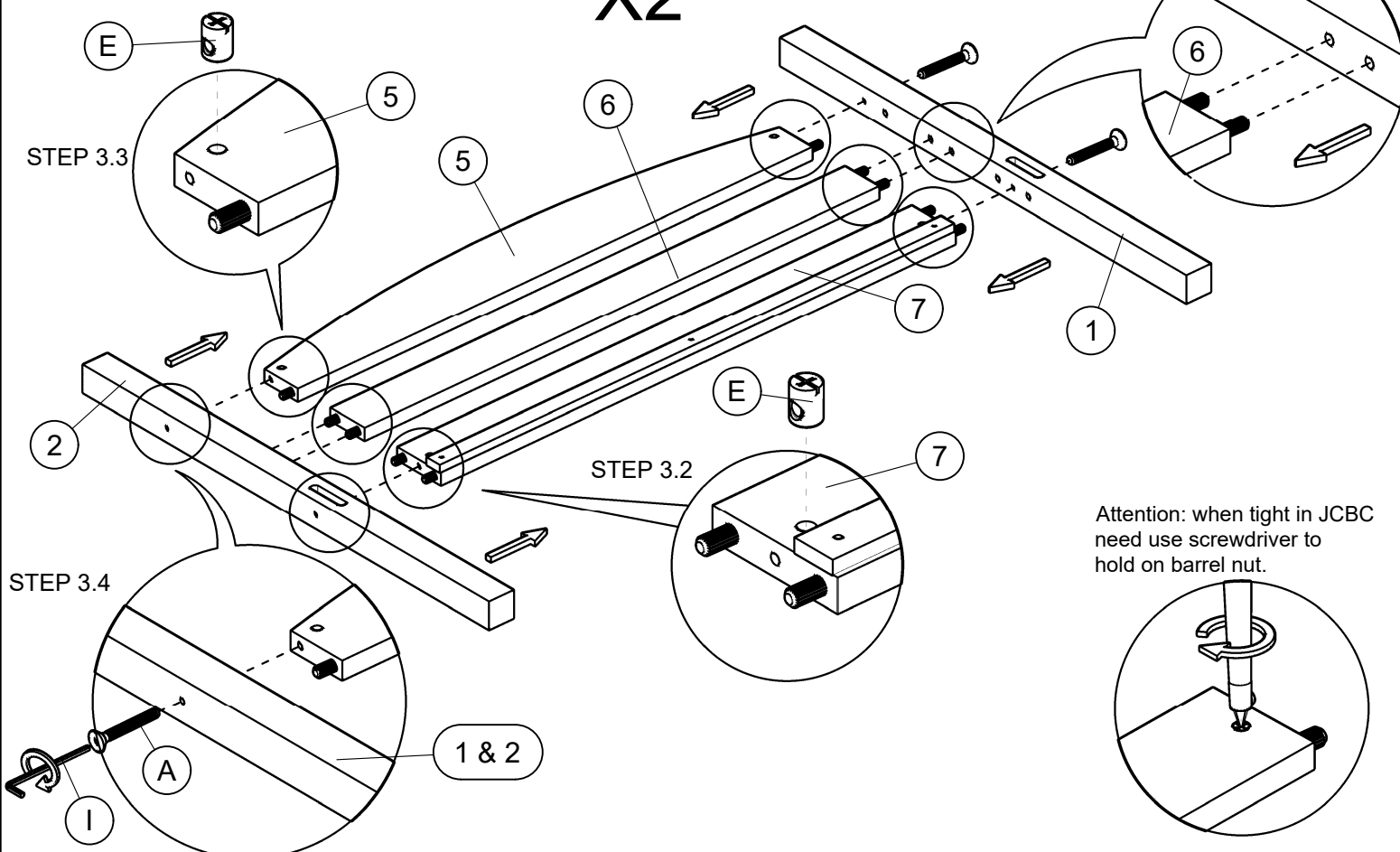

STEP 4

X2

STEP 4.1

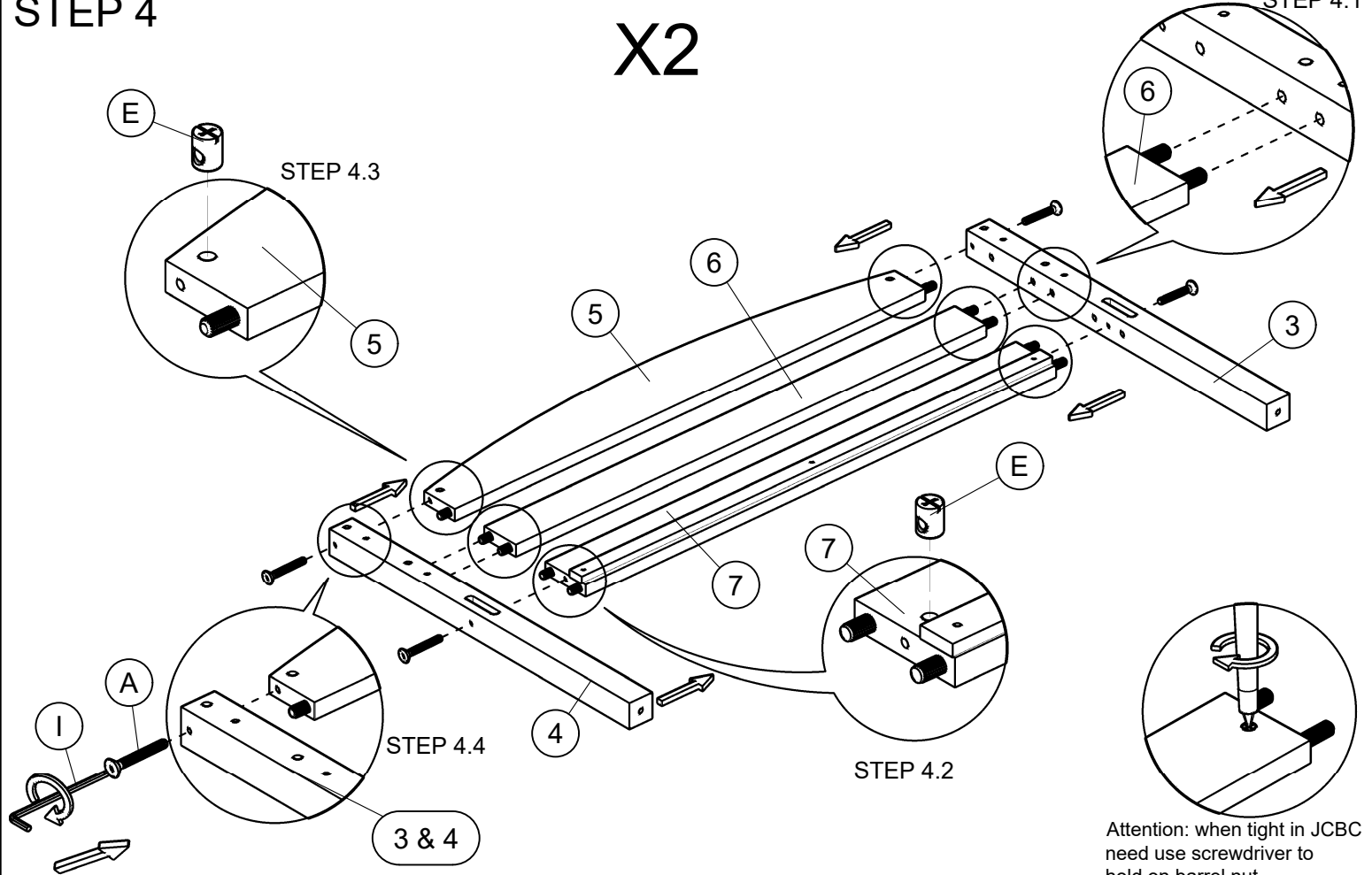

ASSEMBLY INSTRUCTION

STEP 5

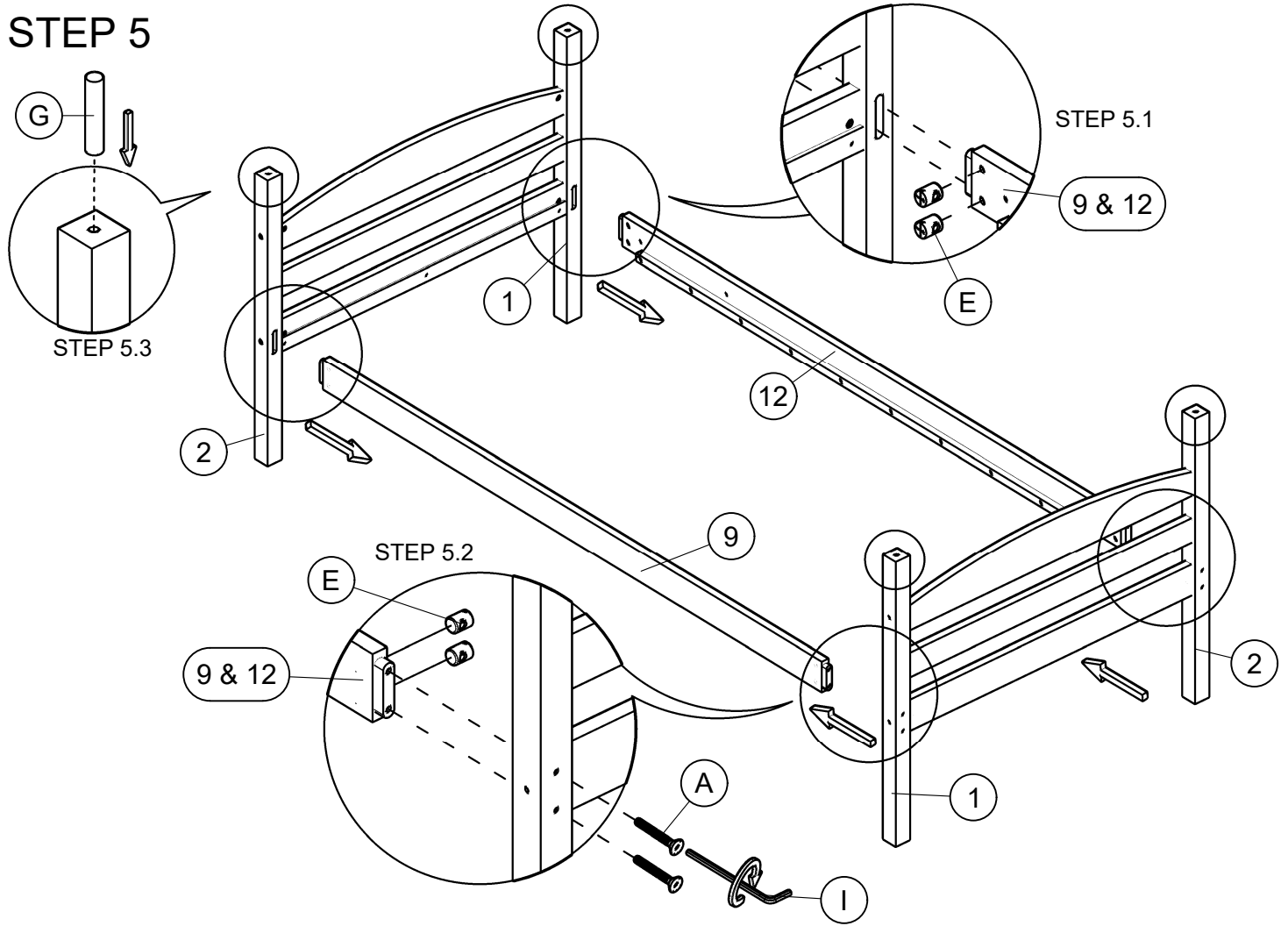

STEP 6

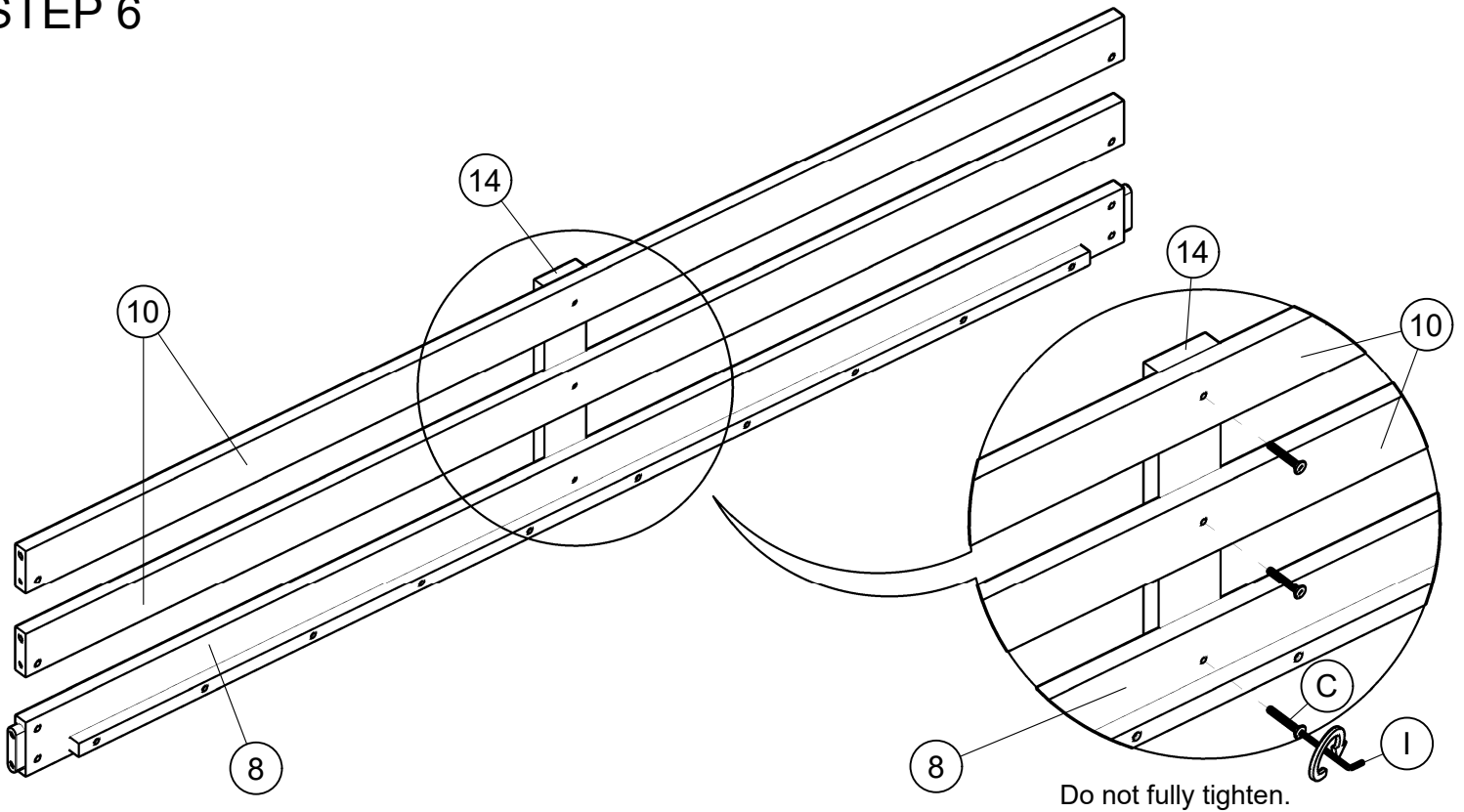

ASSEMBLY INSTRUCTION

STEP 7

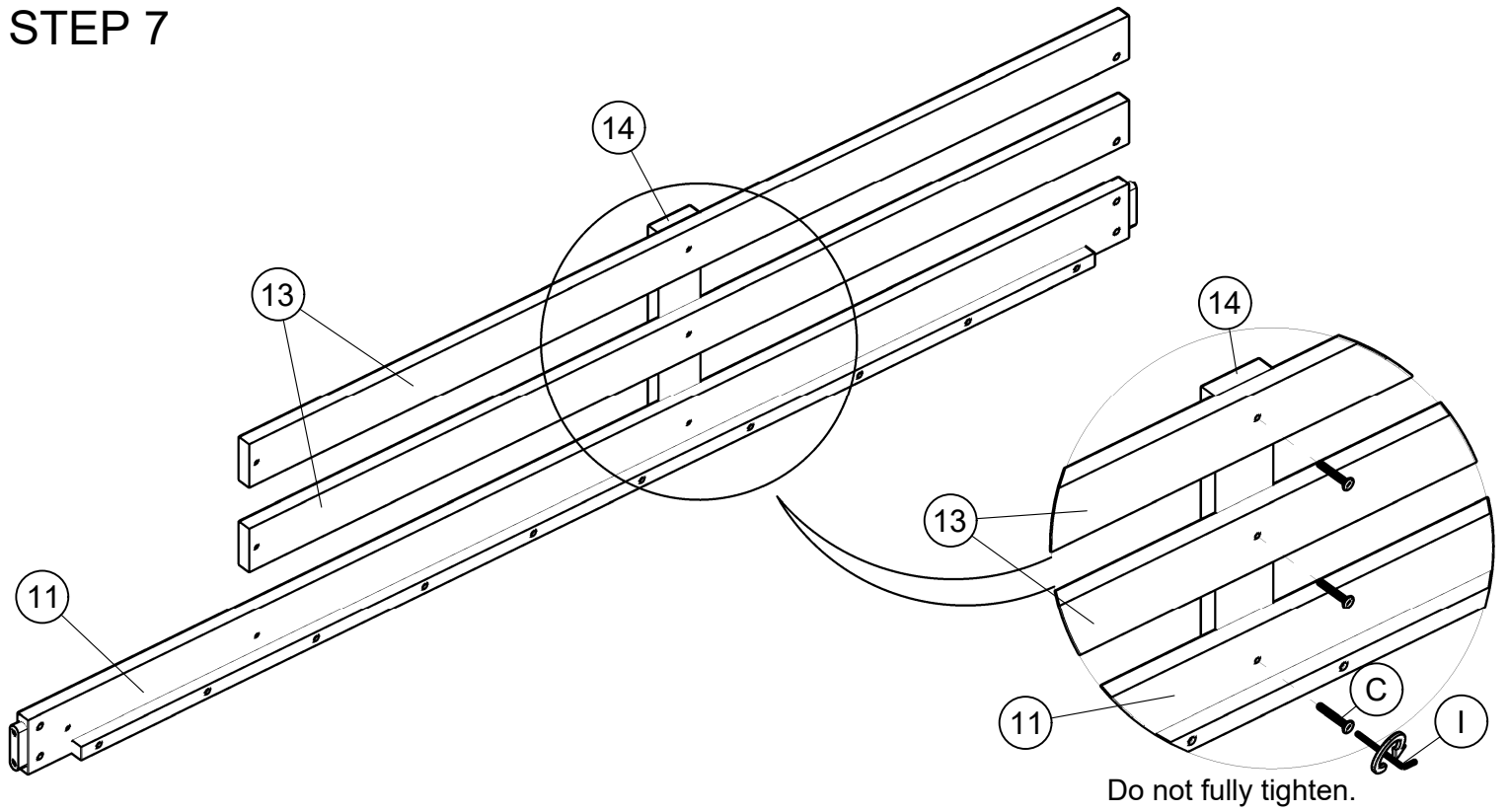

STEP 8

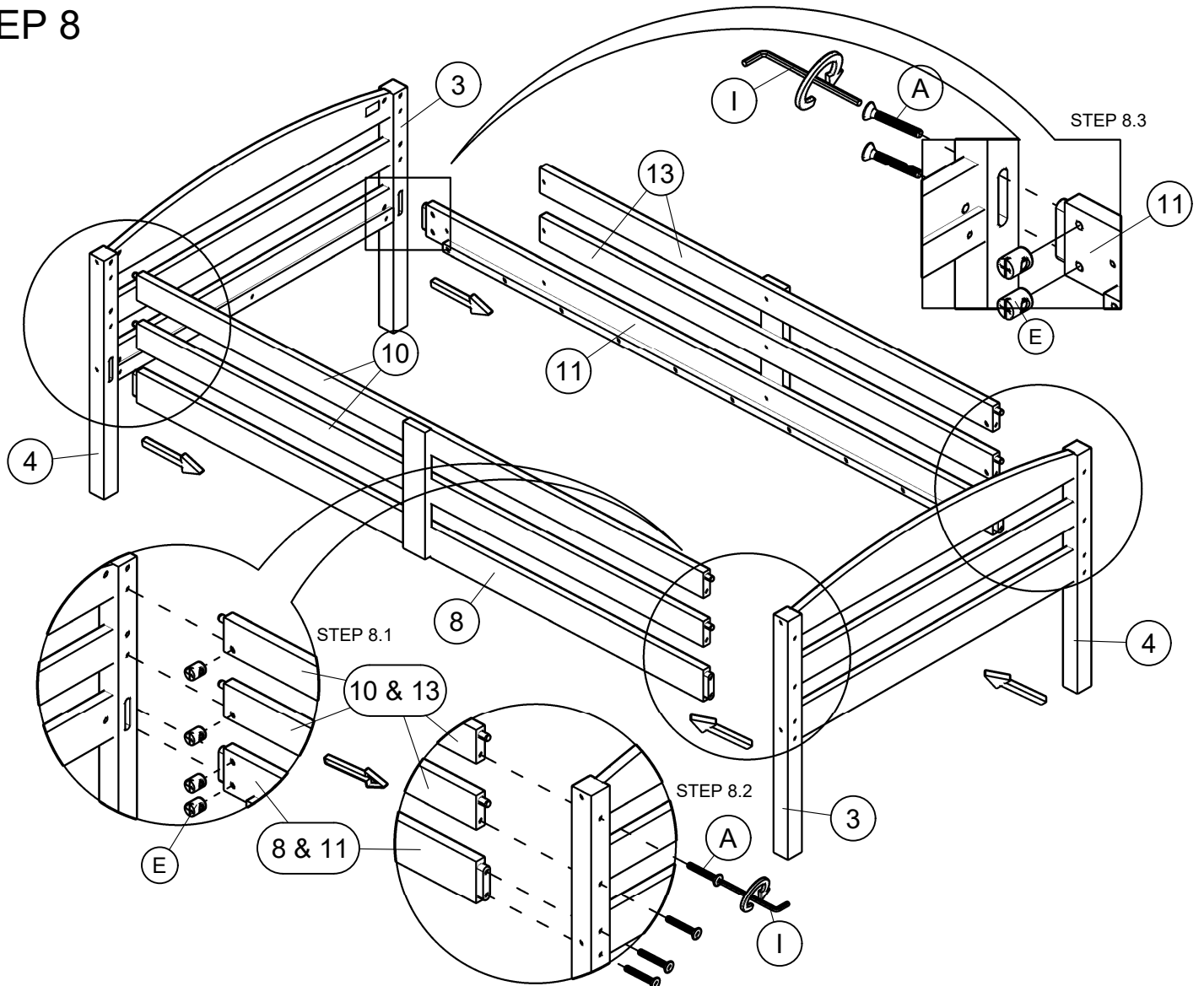

ASSEMBLY INSTRUCTION

STEP 9

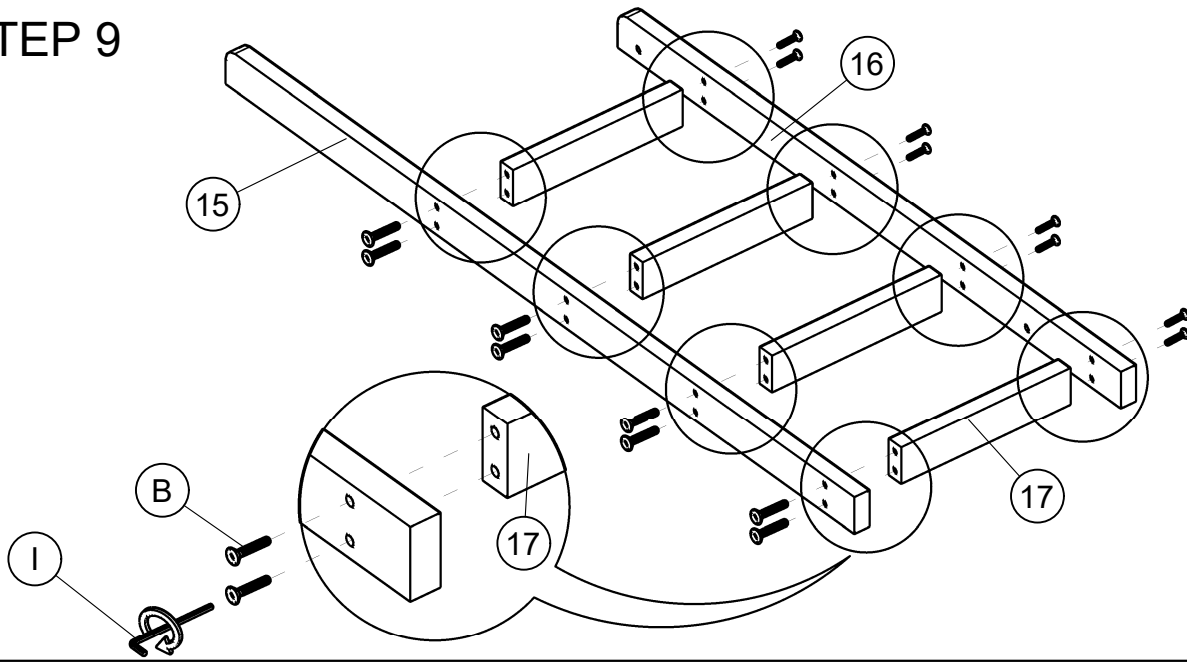

STEP 10

INSIDE VIEW

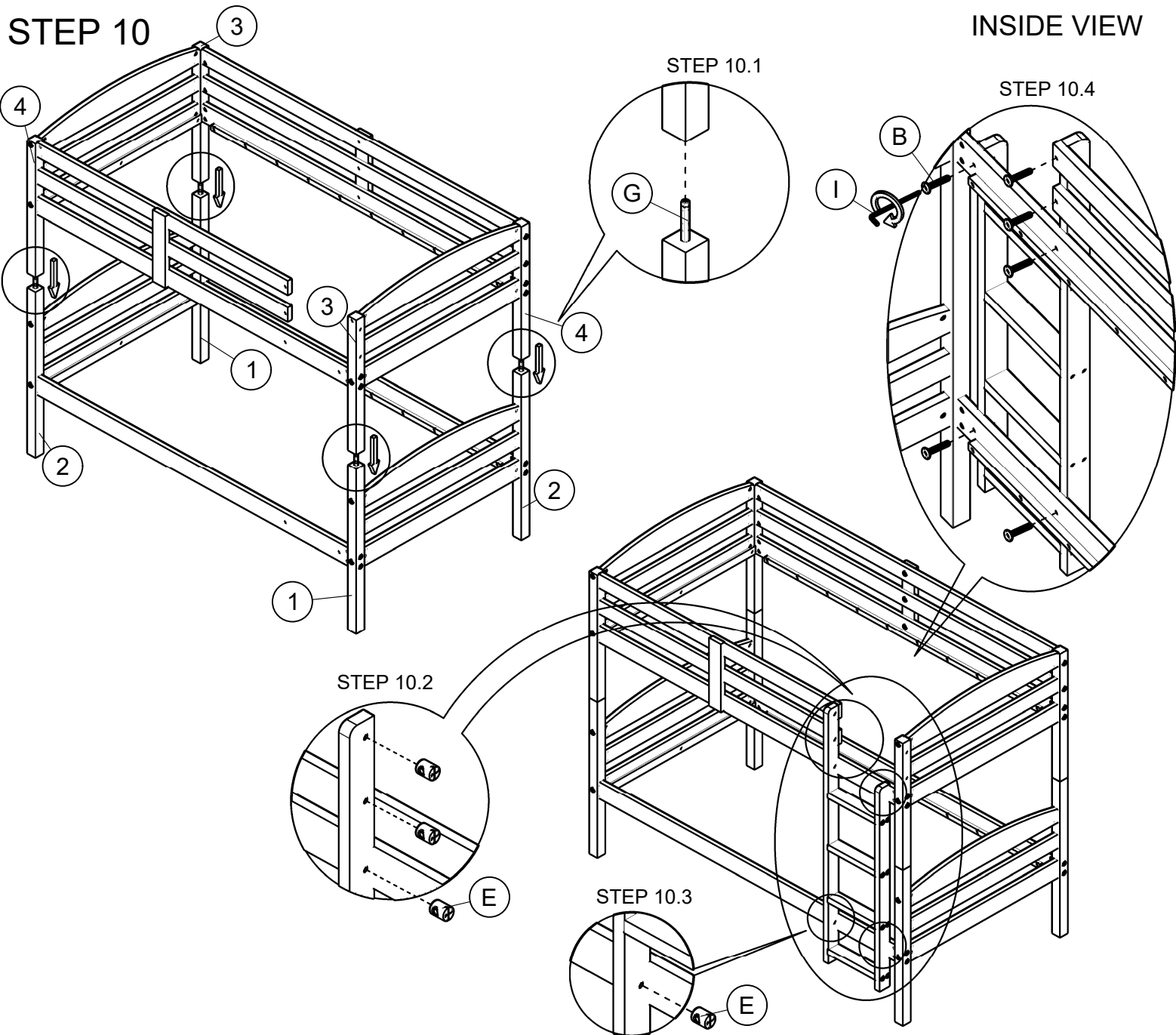

ASSEMBLY INSTRUCTION

STEP 11

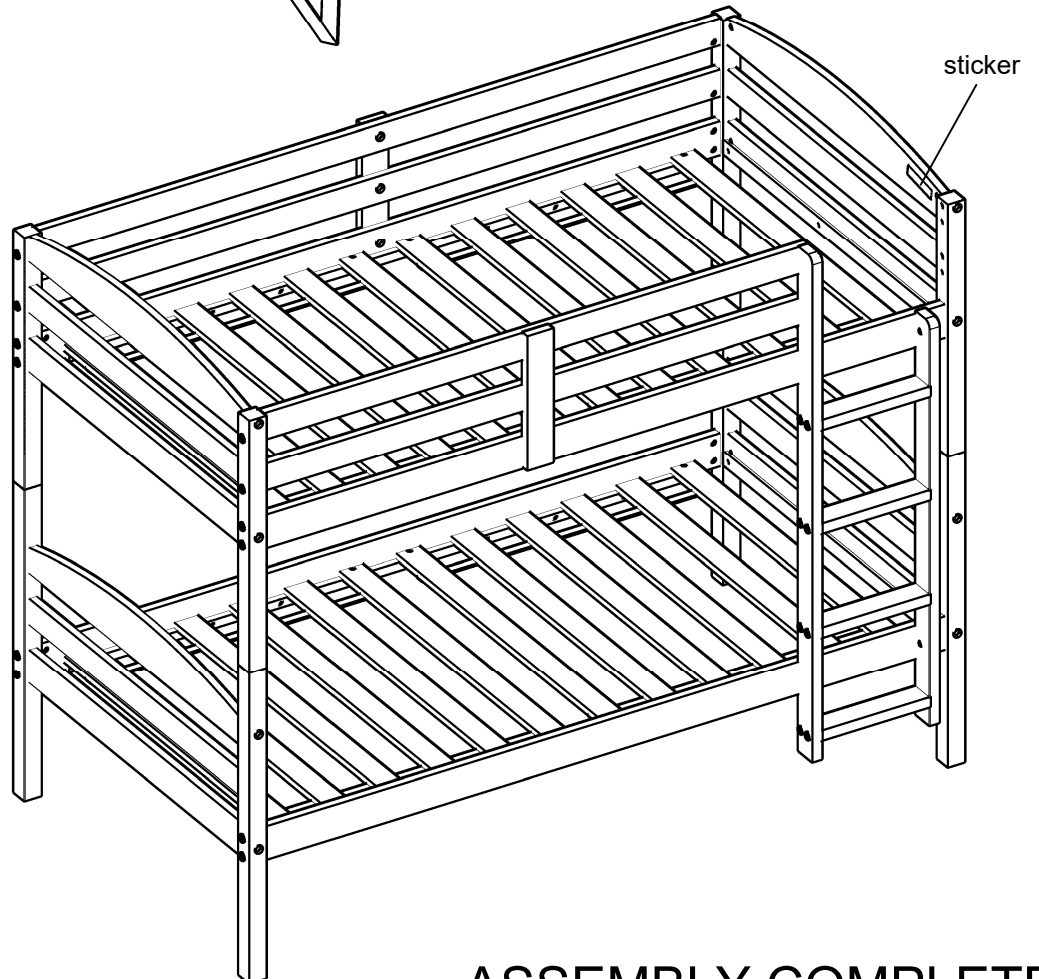
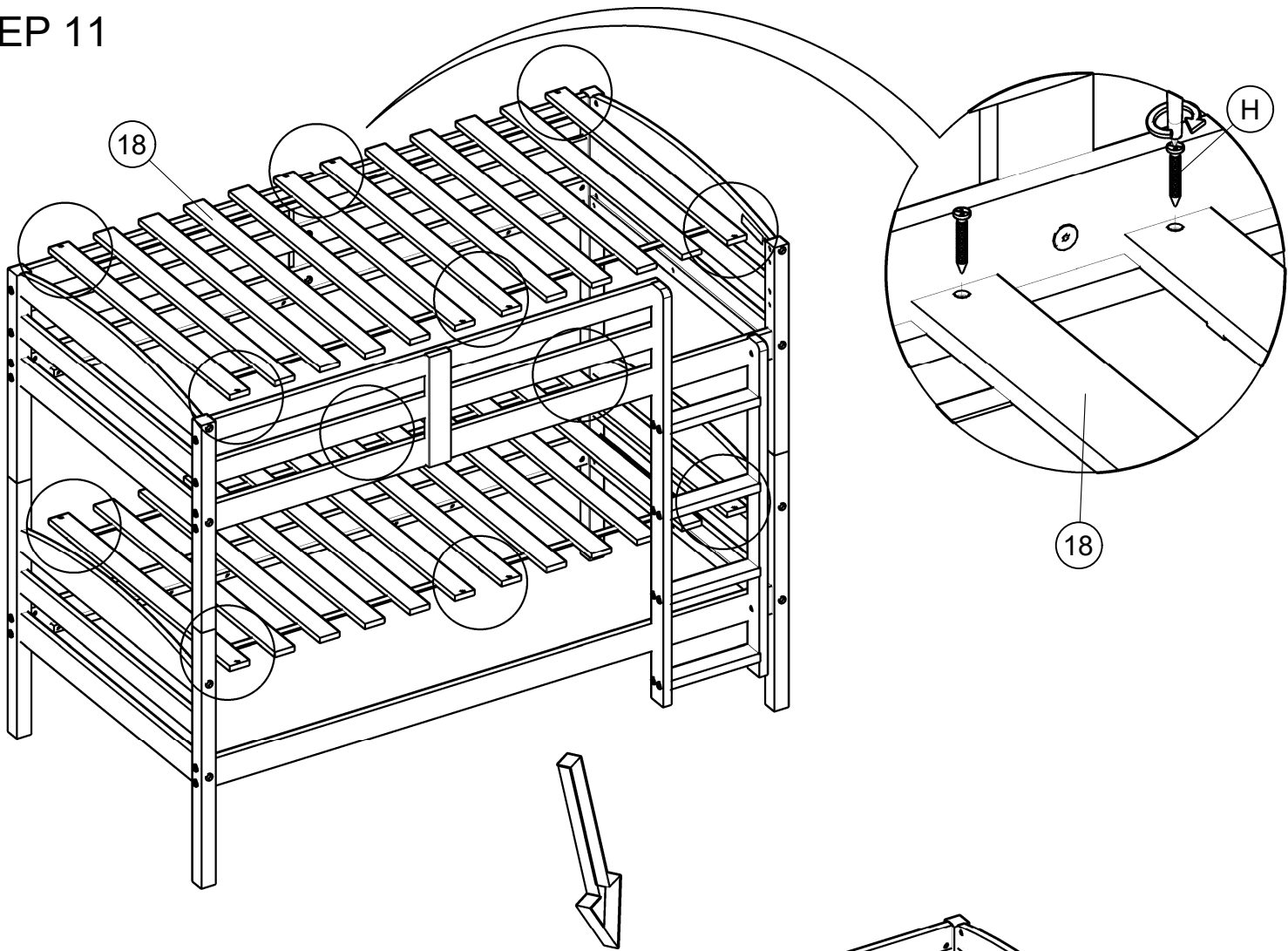

ASSEMBLY COMPLETED

ASSEMBLY INSTRUCTION

To be used as the
footboard for single bed

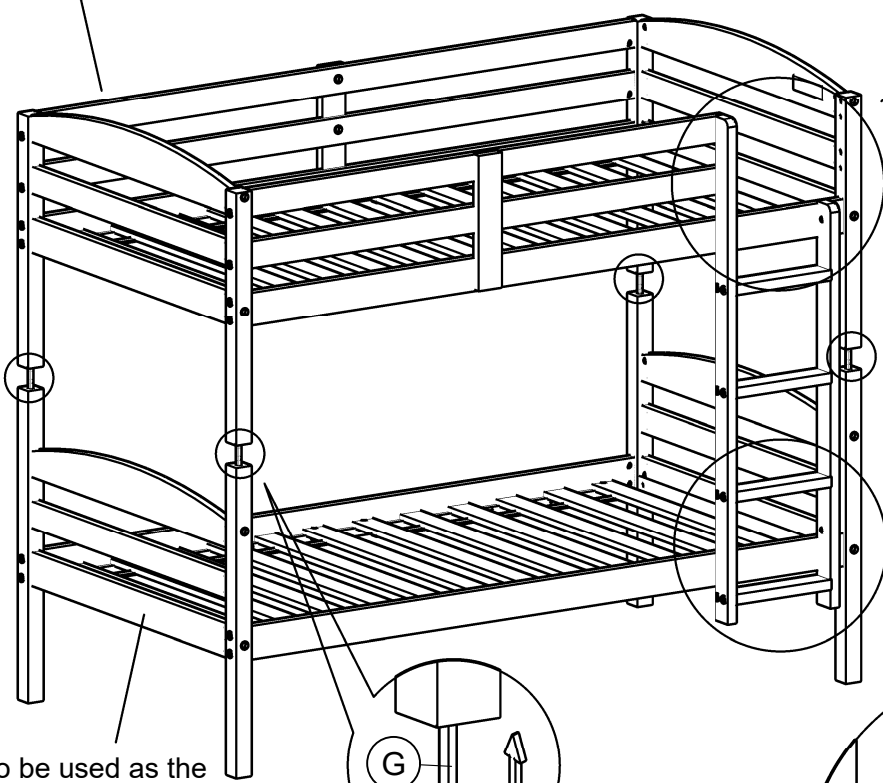

To be used as the
headboard for single bed

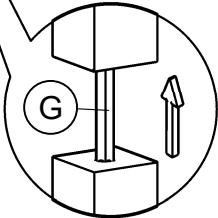

After remove Top bed,
take out metal dowel 4 pcs.

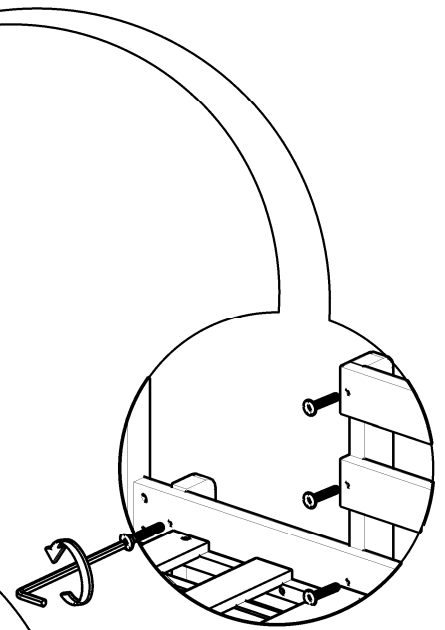

Remove JCBC
to take out ladder.

Foot Board

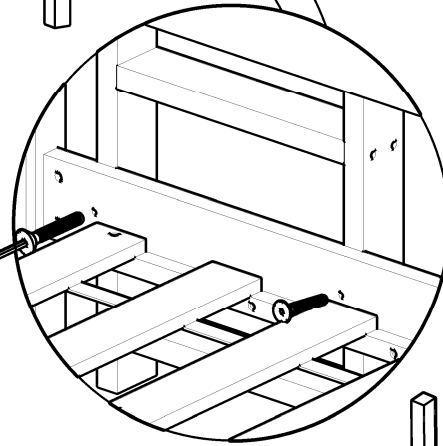

UPPER BED

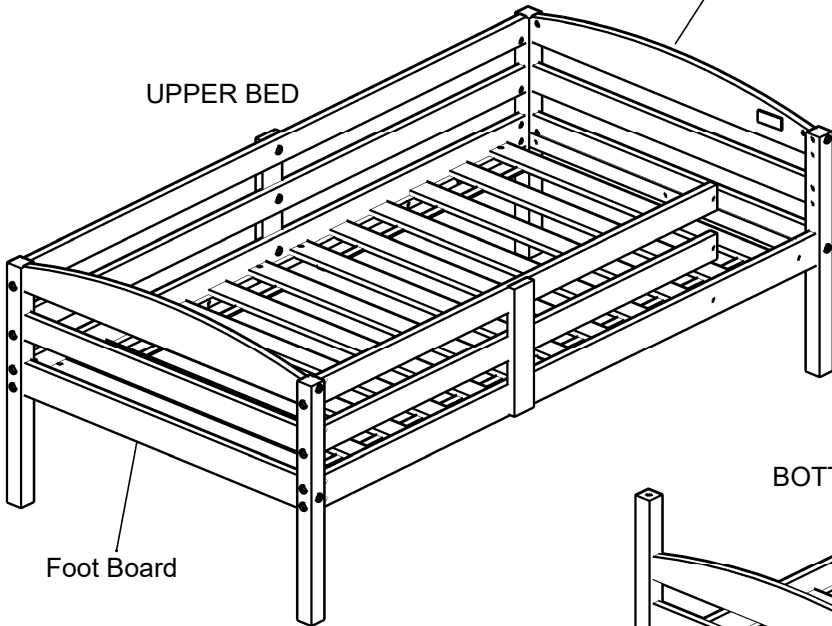

Foot Board

BOTTOM BED

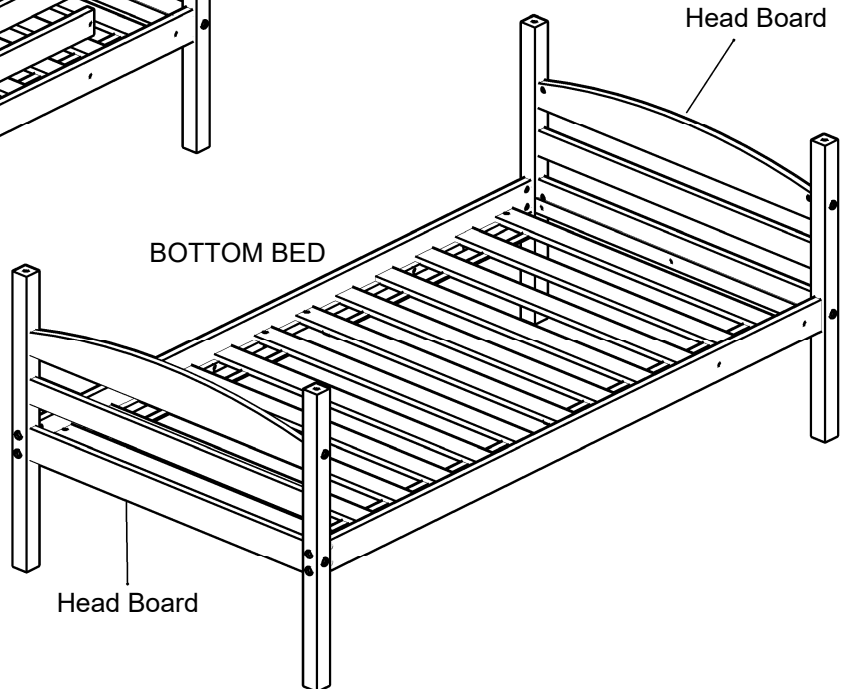

Head Board

Head Board

ASSEMBLY INSTRUCTION

Remove JCBC to
take out part (10,13,14)

Foot Board

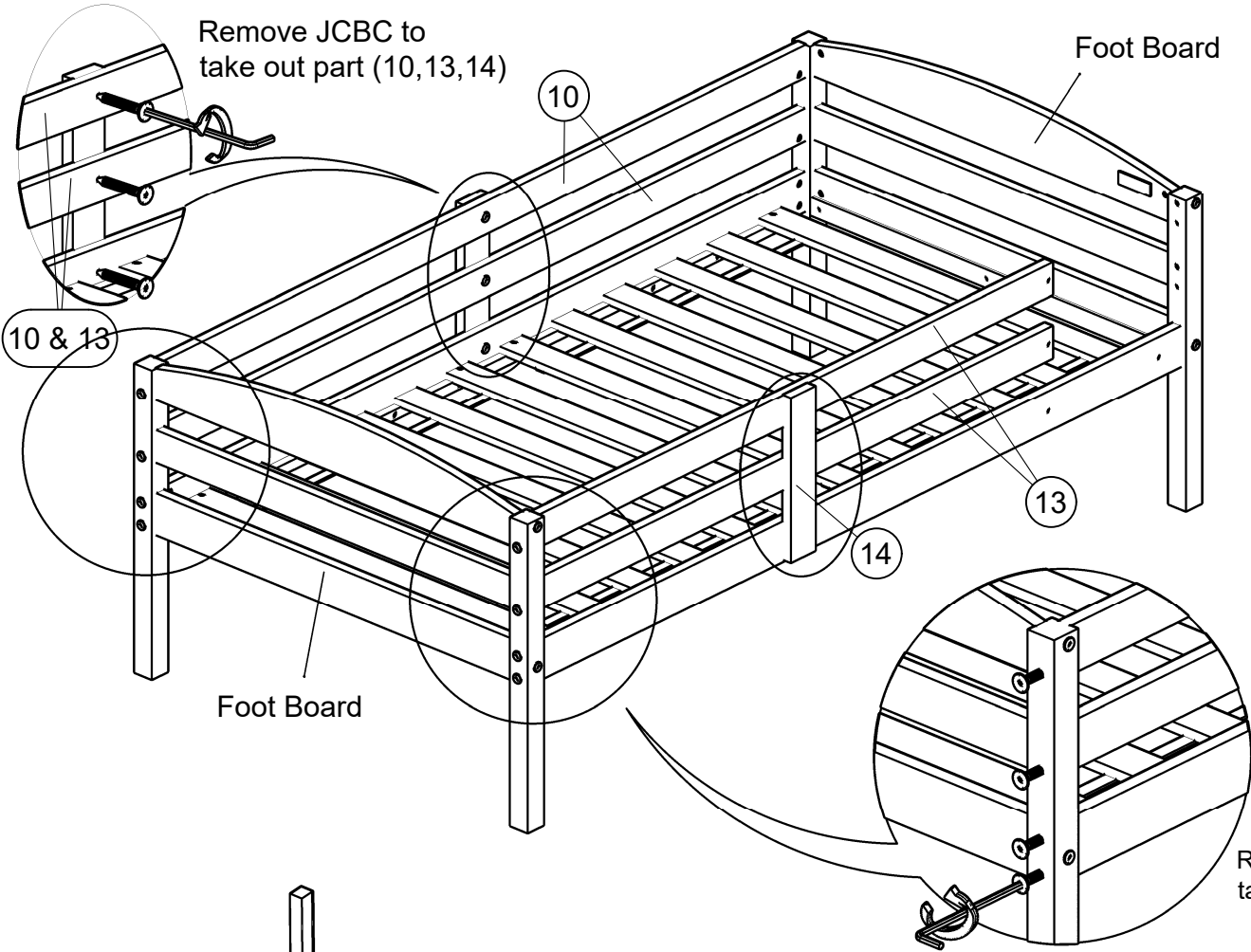

4

8

UPPER BED

Foot Board

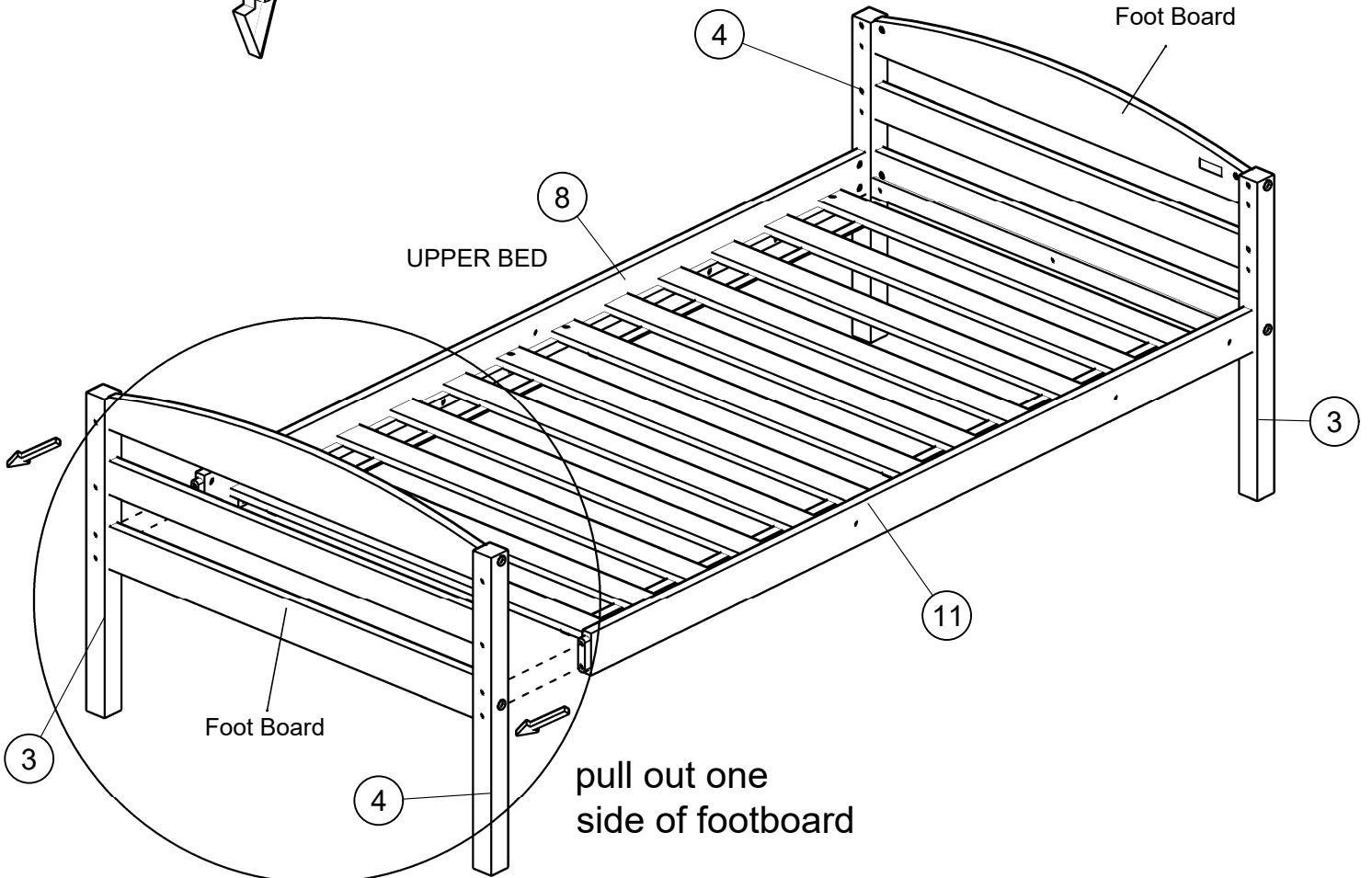

ASSEMBLY INSTRUCTION

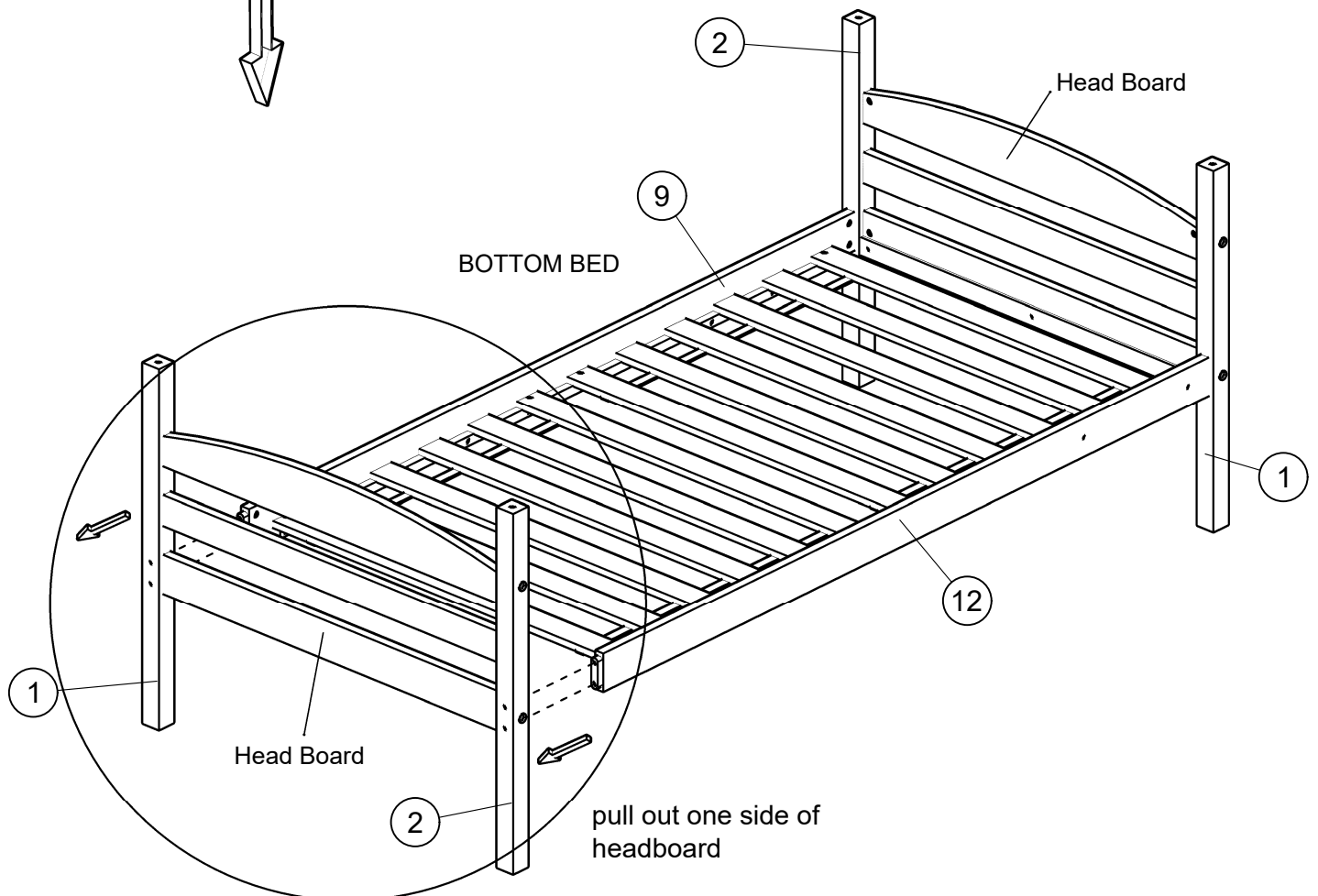
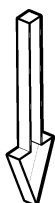
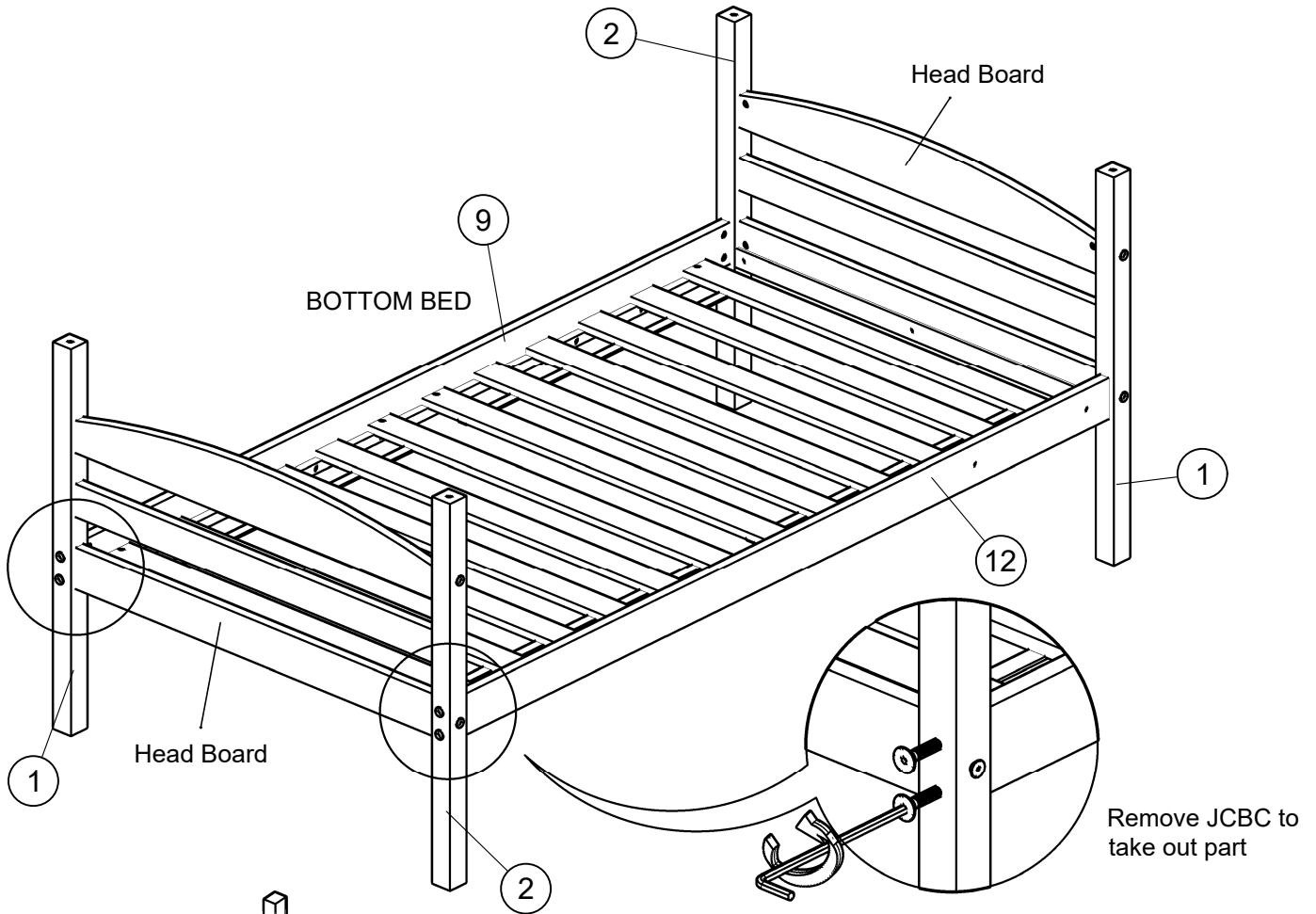

ASSEMBLY INSTRUCTION

Assemble the footboard you just pulled out into the headboard

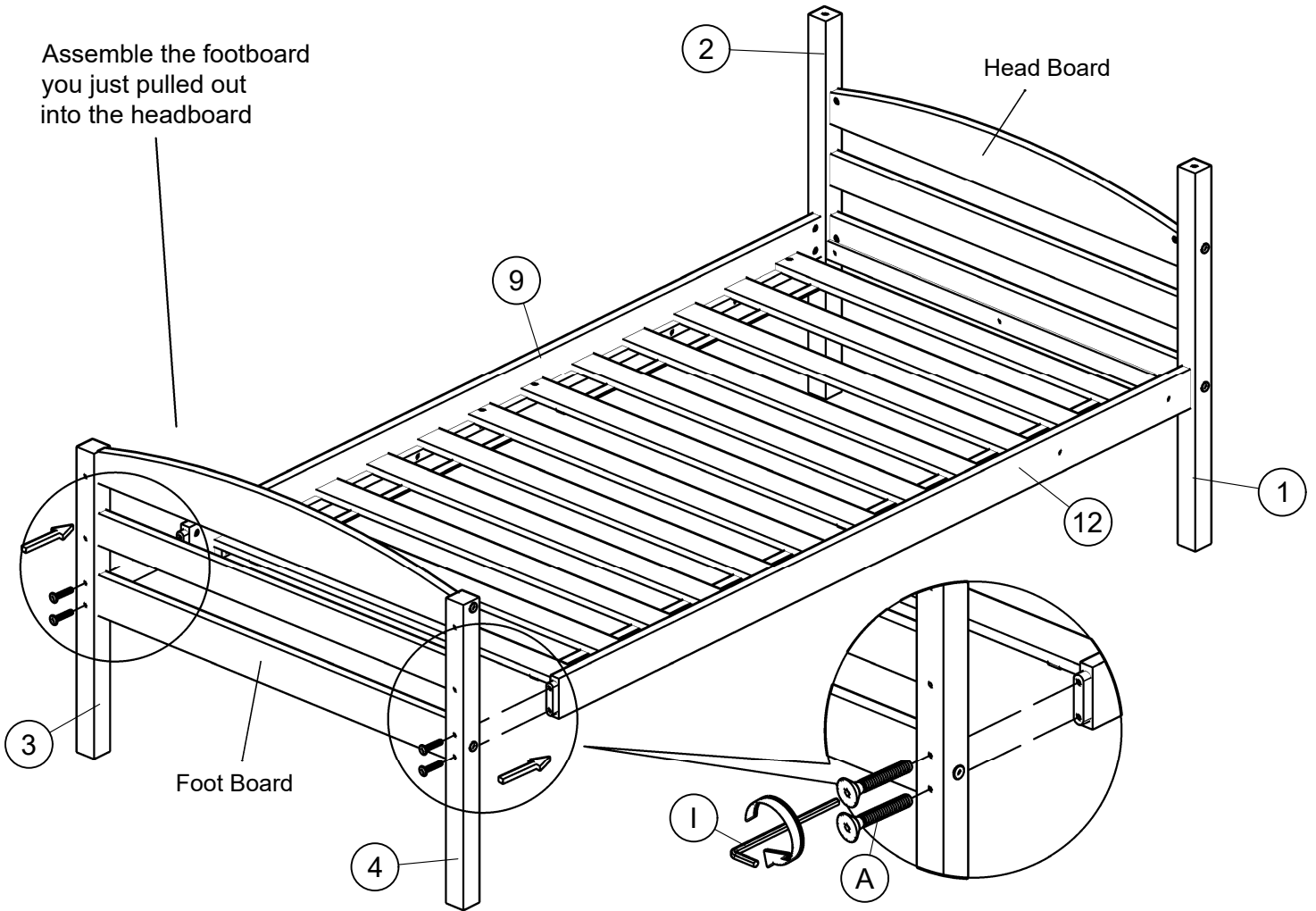

Assemble the headboard you just pulled out into the footboard

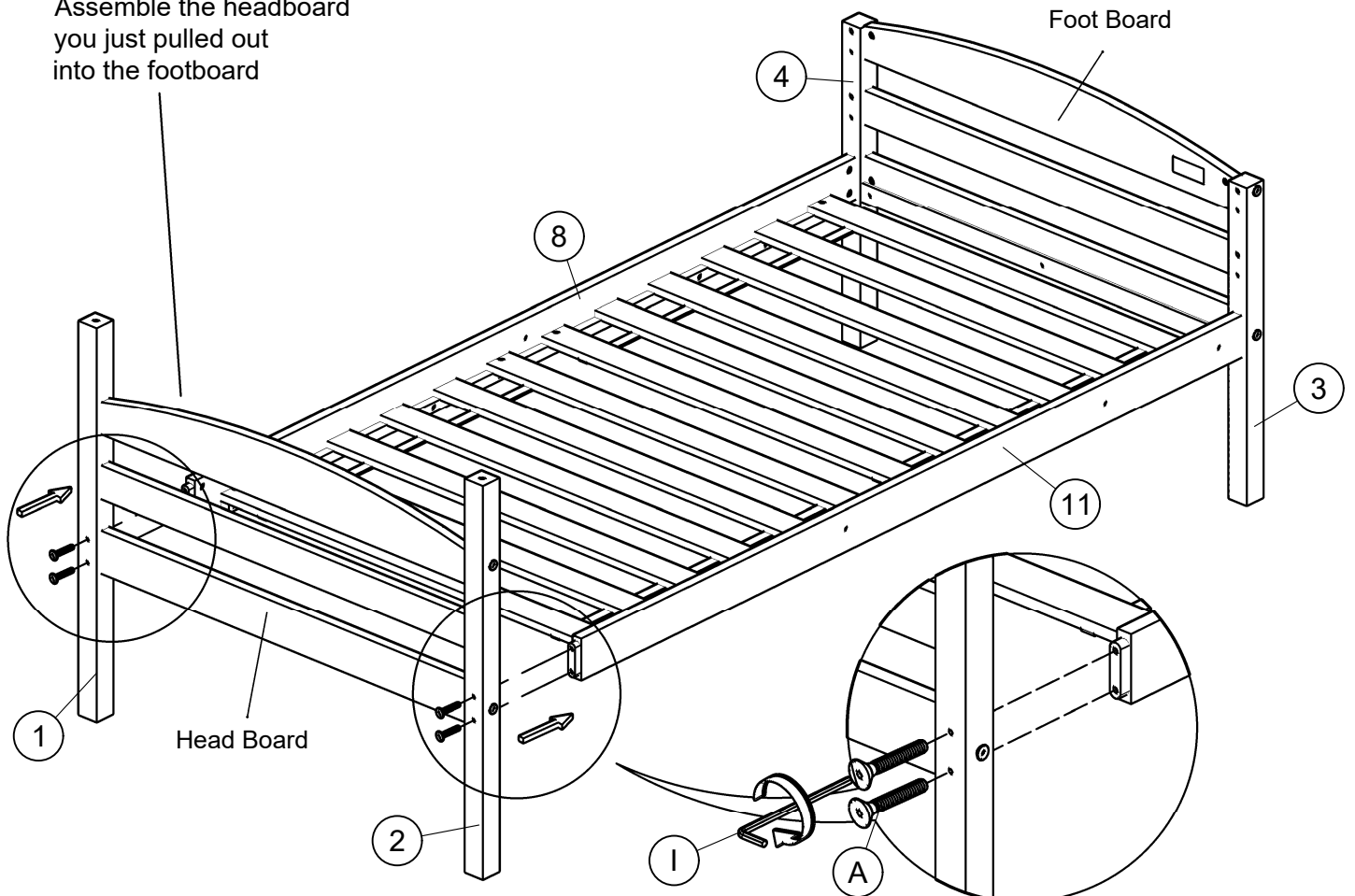

ASSEMBLY INSTRUCTION

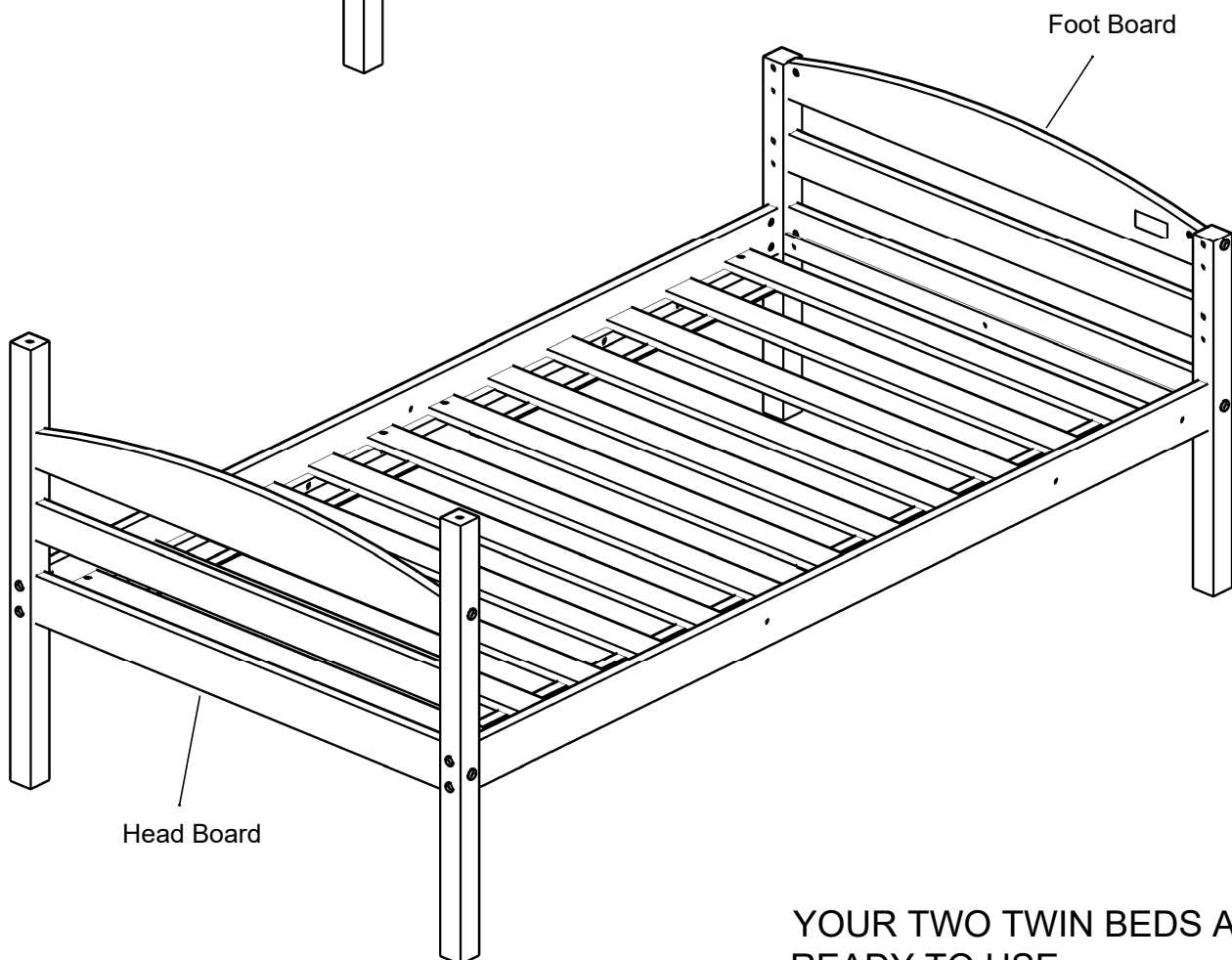
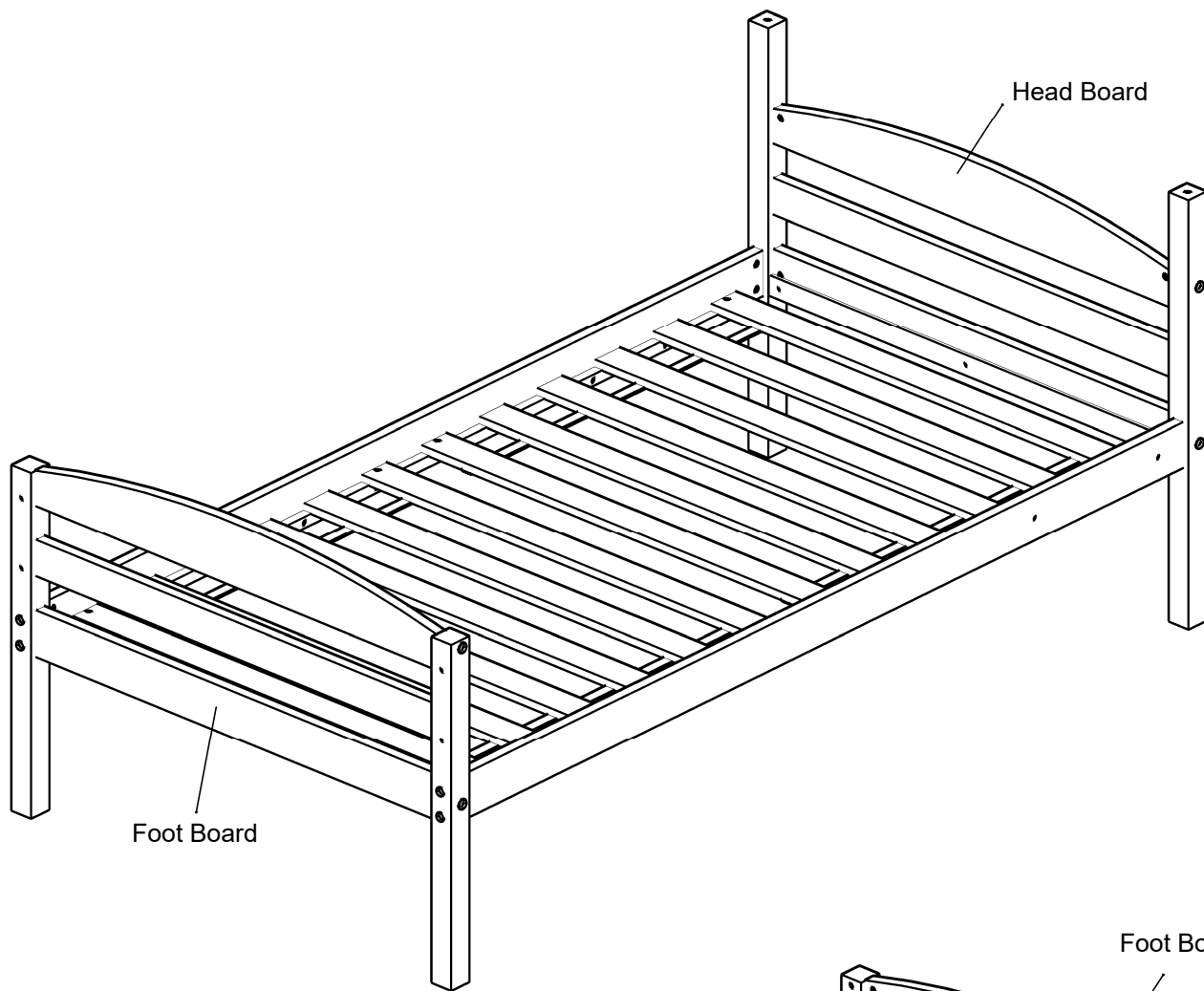

YOUR TWO TWIN BEDS ARE
READY TO USE