

# **Shower Faucet Set Installation Manual**

**W-111(ES)**

# Warranty Duration

All components of this faucet system are covered under a lifetime limited warranty, ensuring they are free from defects in material and workmanship for the original purchaser.

# Repair and Replacement

If the product shows defects in material or workmanship under normal use and within the warranty period, we will, at our discretion, either repair the product or provide a replacement at no cost to the original purchaser. Please note that proof of purchase (e.g., an invoice) is required when requesting service. The warranty does not cover damages caused by improper installation, misuse, or modifications.

# Exclusions

We shall not be responsible for the following cases:

- Damage to the product caused by improper installation, misuse, unauthorized repair or replacement, or abuse (including damage during shipment).
- Damage to the product caused by improper dismantling after installation.
- Damage resulting from abnormal water pressure or impurities in water pipes, which is not covered under this warranty.
- Rust on the product due to insufficient care and maintenance, which is not covered under this warranty.
- Damage caused by natural disasters such as fire, flood, earthquake, lightning storms, etc., which is not covered under this warranty.

I hope this helps! If you have any further questions or concerns, please let me know.

# Having Trouble? Contact us.

 Email: [info@faucetsupport.com](mailto:info@faucetsupport.com)

 Toll Free: 1-888-969-6880



**M6993**  
**SFS-1154**

## **CONTENT**

**1. Installation Instructions for Thermostatic Shower Faucet ----- (1-6)**

## **CONTENIDO**

**1. Instrucciones de instalación para el grifo de ducha termostático---(7-12)**

## ◆ Installation and Maintenance Matters

1. Check the accessories list to verify that all parts are complete in this package.
2. Do not disassemble the main body by yourself.
3. Connect inlet pipes to supply valves.
4. Make sure inlet pipes and supply valves have no impurities and are cleaned, with no impurities in the pipeline.
5. After installation, check all joints for leakages.
6. Do not leave the rain shower system exposed to a severely corrosive environment.

### Do's

1. In order to keep the mixer surface bright, please clean the mixer regularly.
2. Rinse the faucet with clean water and wipe it with a soft cotton cloth.
3. Use one of the following cleaners to remove dirt from the surface: a. Mild liquid cleaner. b. Colorless glass cleaner and powder cleaner that do not cause abrasion and can be dissolved completely. c. Polish liquid that does not cause abrasion.

### Don'ts

1. Avoid using cleaning powder, harsh cleaning chemicals, brushes and coarse cloth to prevent scratching and friction.
2. Do not use acid cleaners to clean the faucet as they may cause surface corrosion of the faucet. If the faucet is exposed to harmful acid substances, please rinse it immediately with water.

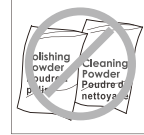
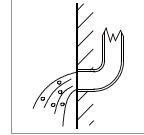
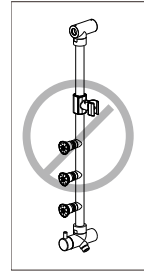

### Tools Needed:

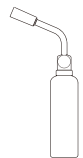
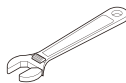
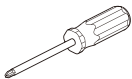

◆ **Three-Function Shower Set Accessories List**

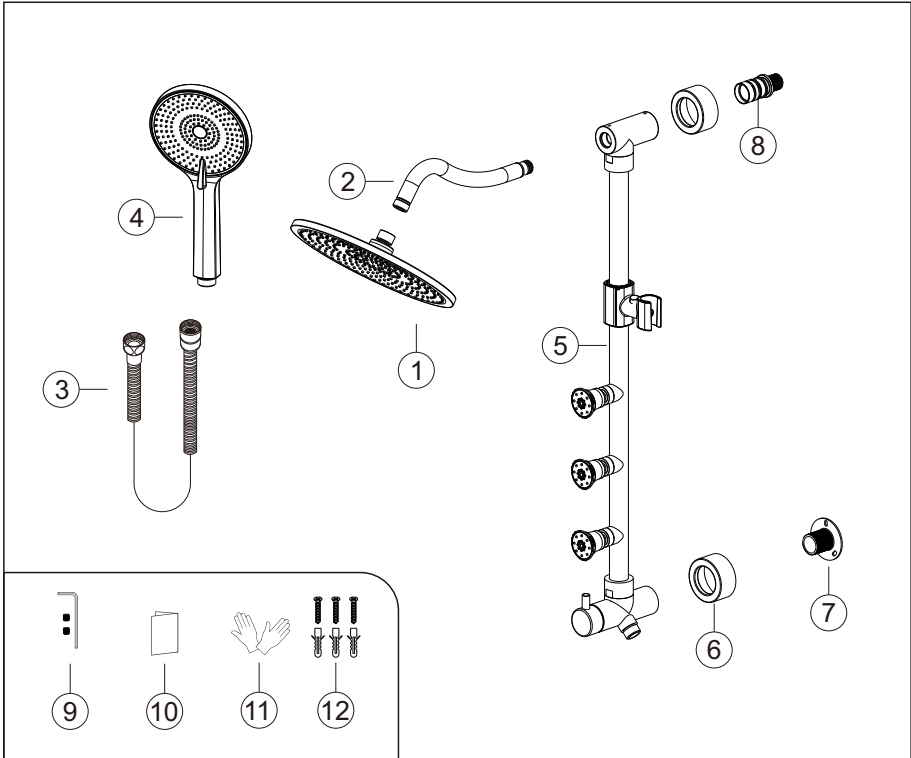

| No. | Part name   | Qty | No. | Part name               | Qty   |
|-----|-------------|-----|-----|-------------------------|-------|
| 1   | Shower head | 1   | 7   | Mounting bracket        | 1     |
| 2   | Shower arm  | 1   | 8   | Water outlet connector  | 2     |
| 3   | Shower hose | 1   | 9   | Screw fittings          | 1set  |
| 4   | Shower hand | 1   | 10  | Instruction manual      | 1     |
| 5   | Main body   | 1   | 11  | Gloves                  | 1pair |
| 6   | Flange      | 2   | 12  | Mounting bracket screws | 1set  |

## ◆ Essential Dimensions & Water Pipe Line

Unit: mm/inch

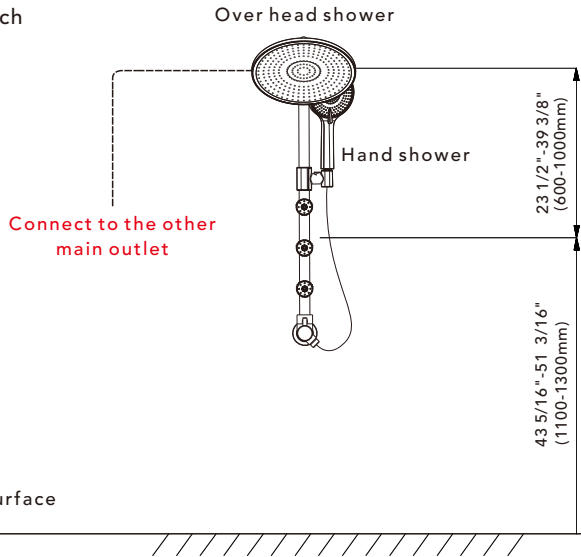

## ◆ Water Outlet Connector Installation Depth

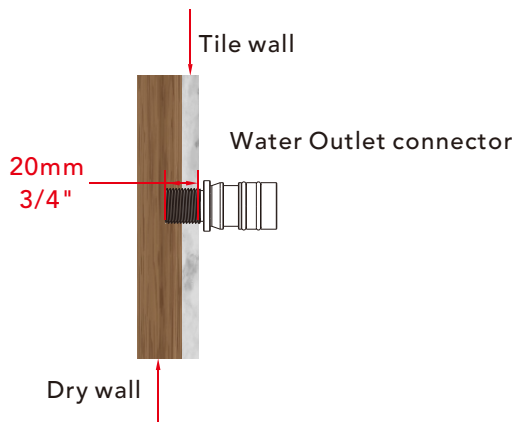

The thickness of the tile must be calculated for installation.

Connector size of male thread: USA: 1/2"-14NPT, Canada: 1/2"-14NPT, Europe: G1/2".

## ◆ Shower Bar Installation

### Step 1

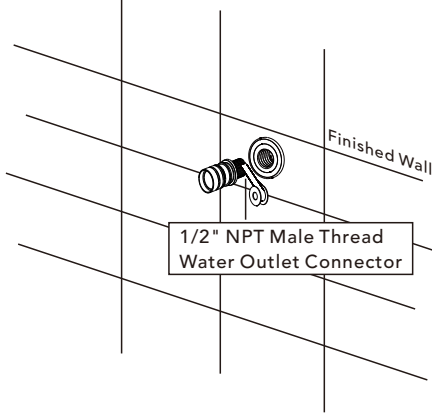

Apply PTFE tape to the male threaded connector and tighten it clockwise into the pre-reserved wall pipe fitting.

### Step 2

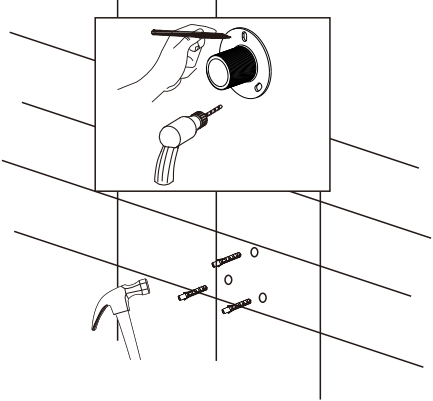

Mark the drilling positions on the wall through the holes of the mounting bracket, then insert the expansion bolts.

### Step 3

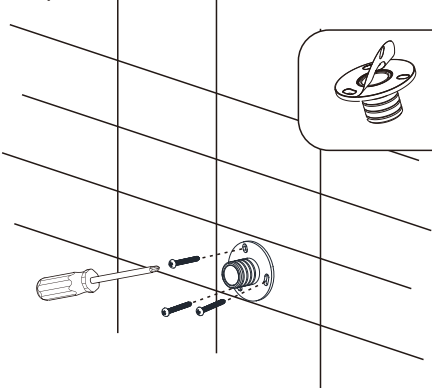

Remove the adhesive film on the back of the mounting bracket, align it with the reserved screw holes, position the bracket, and finally drive in and tighten the screws.

### Step 4

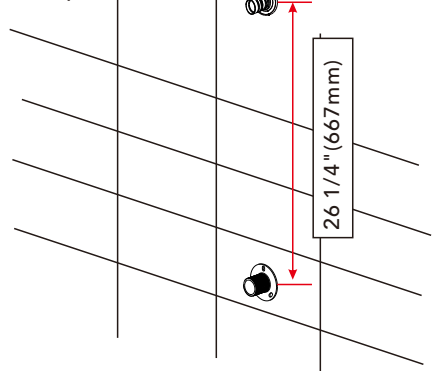

The centers of the water outlet connector and the mounting bracket should be aligned on the same vertical line. The installation distance shown in the diagram is recommended. Any deviation may result in installation failure.

## ◆ Shower Bar Installation

### Step 5

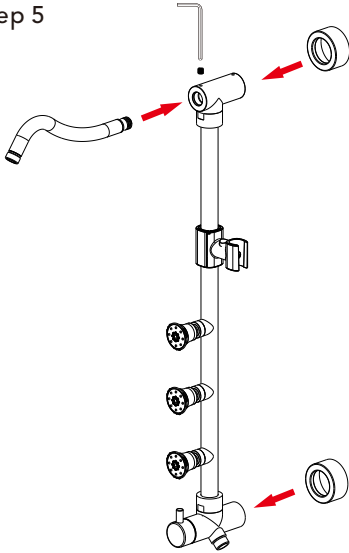

As shown in the diagram, attach the shower arm and the flange to the main body, and then secure the shower arm screw firmly.

### Step 6

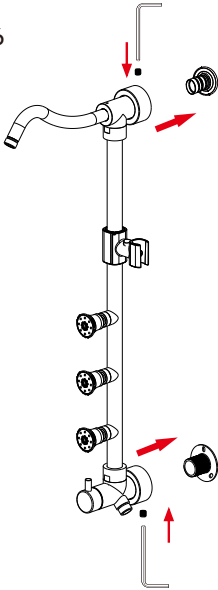

As shown in the diagram, attach the main body to the water outlet connector and the mounting bracket, and tighten the fixing screws securely. Then slide the flange back to the wall until it is completely flush.

## ◆ Shower Head and Shower Hand Installation

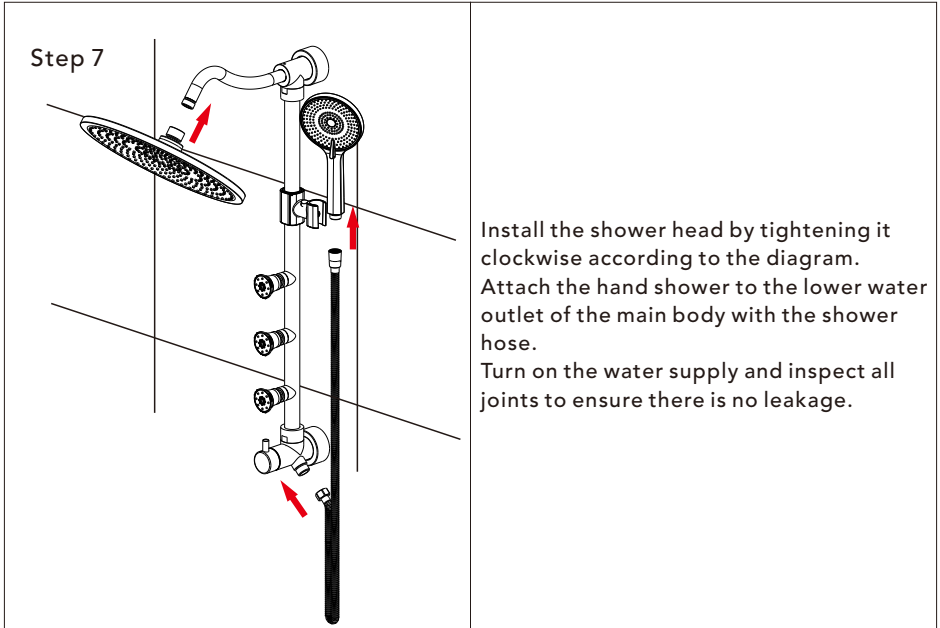

## ◆ Function Instructions

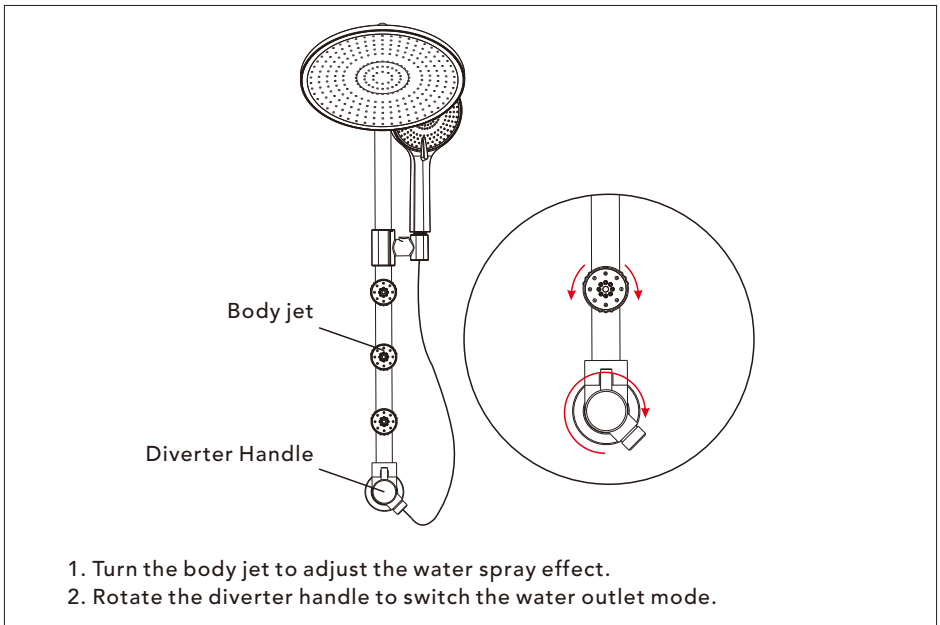

## ◆ Instalación y Cuestiones de Mantenimiento

1. Compruebe la lista de accesorios para verificar que todas las piezas están completas en este paquete.
2. No desmonte el cuerpo principal por su cuenta.
3. Conecte las tuberías de entrada a las válvulas de suministro.
4. Asegúrese de que las tuberías de entrada y las válvulas de suministro no tengan impurezas y estén limpias, y de que no haya impurezas en la tubería.
5. Después de la instalación, compruebe que todas las uniones no presenten fugas.
6. No deje el sistema de ducha tipo lluvia expuesto a un entorno altamente corrosivo.

### Qué Sí Hacer

1. Para mantener brillante la superficie del grifo, límpielo regularmente.
2. Enjuague el grifo con agua limpia y séquelo con un paño de algodón suave.
3. Utilice uno de los siguientes limpiadores para eliminar la suciedad de la superficie:
  - a. Limpiador líquido suave.
  - b. Limpiador de vidrio incoloro y limpiador en polvo que no causen abrasión y se disuelvan completamente.
  - c. Líquido de pulido que no cause abrasión.

### Qué No Hacer

1. Evite el uso de polvos de limpieza, productos químicos de limpieza agresivos, cepillos y trapos ásperos para evitar arañazos y rozaduras.
2. No utilice limpiadores ácidos para limpiar el grifo, ya que pueden causar corrosión en la superficie. Si el grifo entra en contacto con sustancias ácidas dañinas, enjuáguelo inmediatamente con agua.

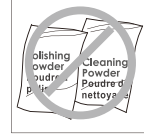
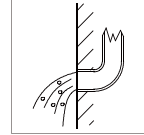
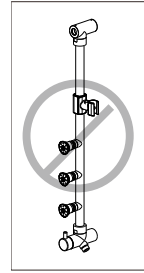

## Herramientas Necesarias:

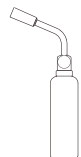
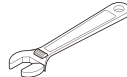
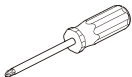

◆ **Three-Function Shower Set  
Accessories List**

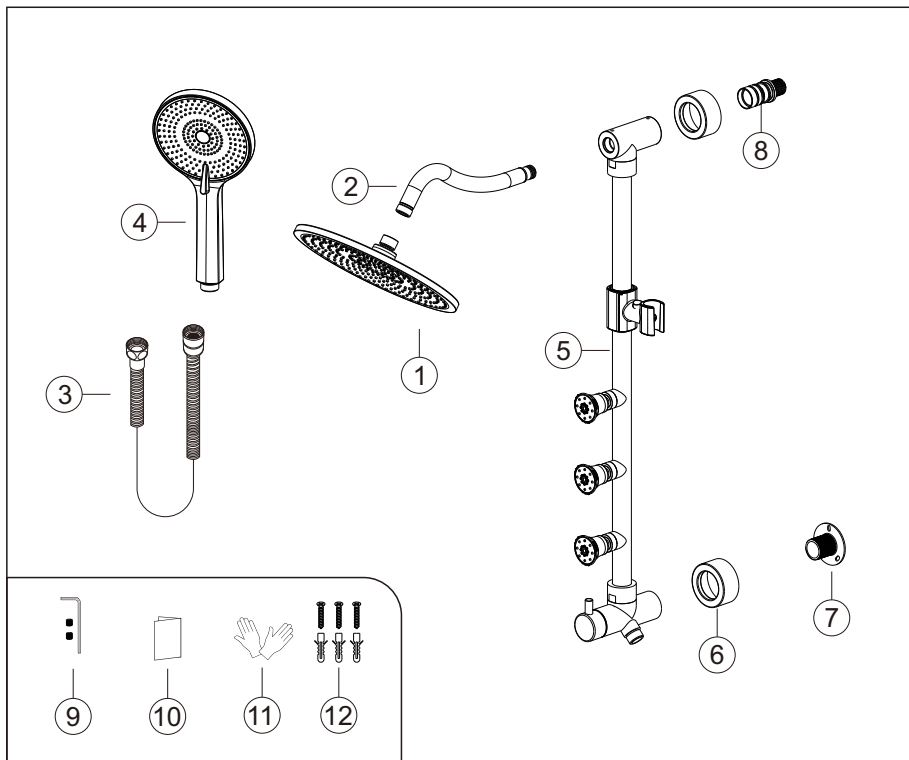

| N.º | Nombre de la pieza | Cant. | N.º | Nombre de la pieza               | Cant.   |
|-----|--------------------|-------|-----|----------------------------------|---------|
| 1   | Cabezal de ducha   | 1     | 7   | Soporte de montaje               | 1       |
| 2   | Brazo de ducha     | 1     | 8   | Conector de salida de agua       | 2       |
| 3   | Manguera de ducha  | 1     | 9   | Accesorios de tornillería        | 1 juego |
| 4   | Ducha de mano      | 1     | 10  | Manual de instrucciones          | 1       |
| 5   | Cuerpo principal   | 1     | 11  | Guantes                          | 1 par   |
| 6   | Brida              | 2     | 12  | Tornillos del soporte de montaje | 1 juego |

## ◆ Dimensiones esenciales & línea de tubería de agua

Unidad: mm/pulgada

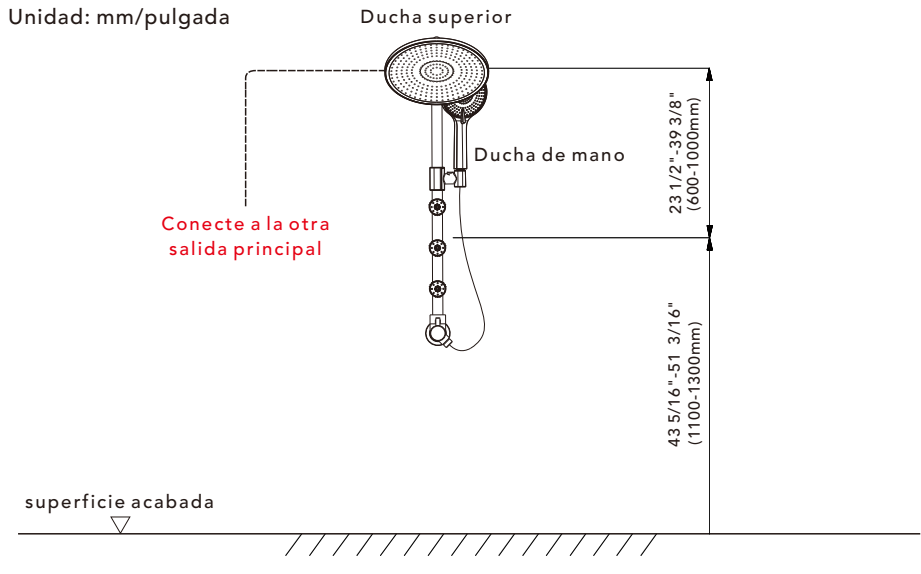

## ◆ Profundidad de instalación del conector de salida de agua

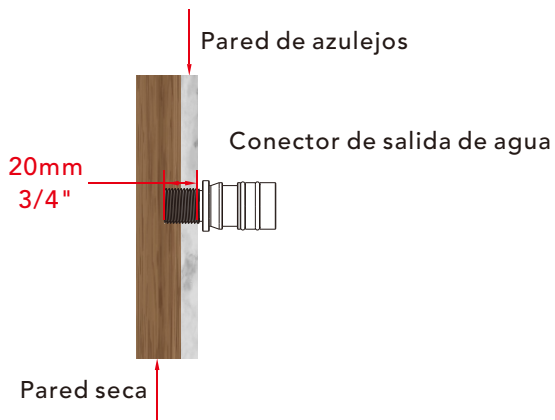

El grosor del azulejo debe ser calculado para la instalación.

Tamaño del conector de rosca macho: EE. UU.: 1/2"-14NPT, Canadá: 1/2"-14NPT, Europa: G1/2".

## ◆ Shower Bar Installation

### Paso 1

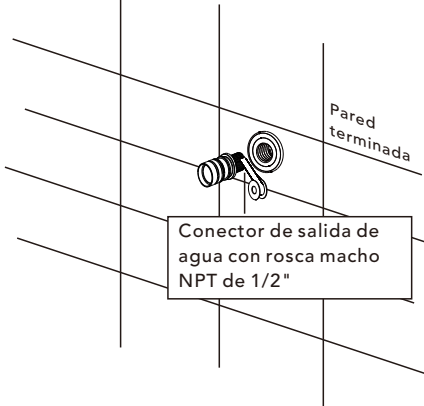

Enrolle cinta de PTFE en el conector roscado macho y enrósquelo en el accesorio de tubería empotrado en la pared, girándolo en el sentido de las agujas del reloj.

### Paso 2

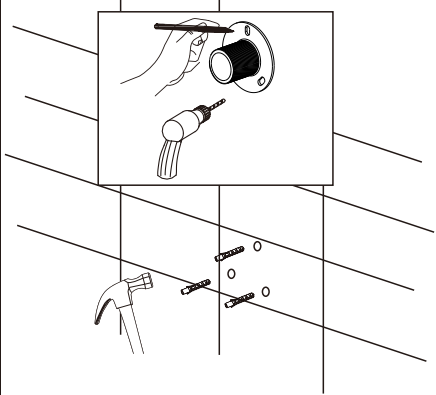

Mark the drilling positions on the wall through the holes of the mounting bracket, then insert the expansion bolts.

### Paso 3

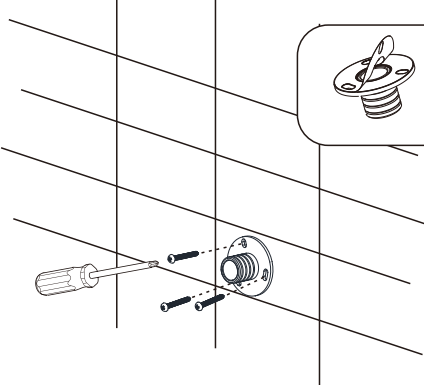

Remove the adhesive film on the back of the mounting bracket, align it with the reserved screw holes, position the bracket, and finally drive in and tighten the screws.

### Paso 4

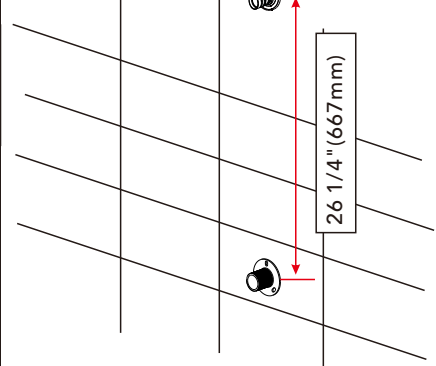

The centers of the water outlet connector and the mounting bracket should be aligned on the same vertical line. The installation distance shown in the diagram is recommended. Any deviation may result in installation failure.

## ◆ Shower Bar Installation

Paso 5

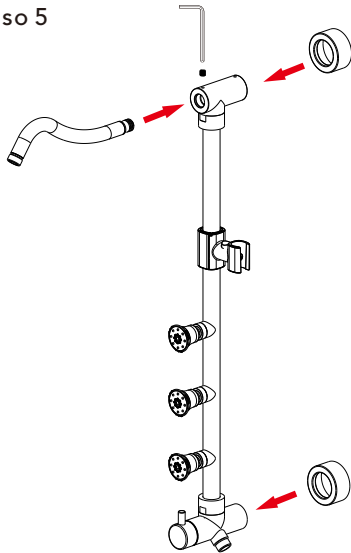

Como se muestra en el diagrama, monte el brazo de ducha y el embellecedor en el cuerpo principal y, a continuación, fije firmemente el tornillo del brazo de ducha.

Paso 6

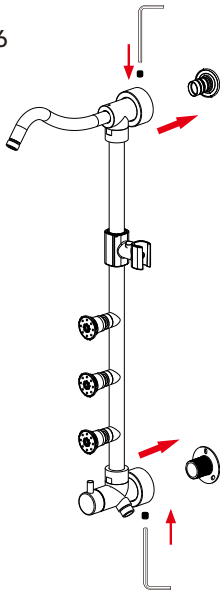

Como se muestra en el diagrama, acople el cuerpo principal al conector de salida de agua y al soporte de montaje, y apriete firmemente los tornillos de fijación. A continuación, deslice el embellecedor hacia la pared hasta que quede completamente enrasado.

## ◆ Instalación del rociador y de la ducha de mano

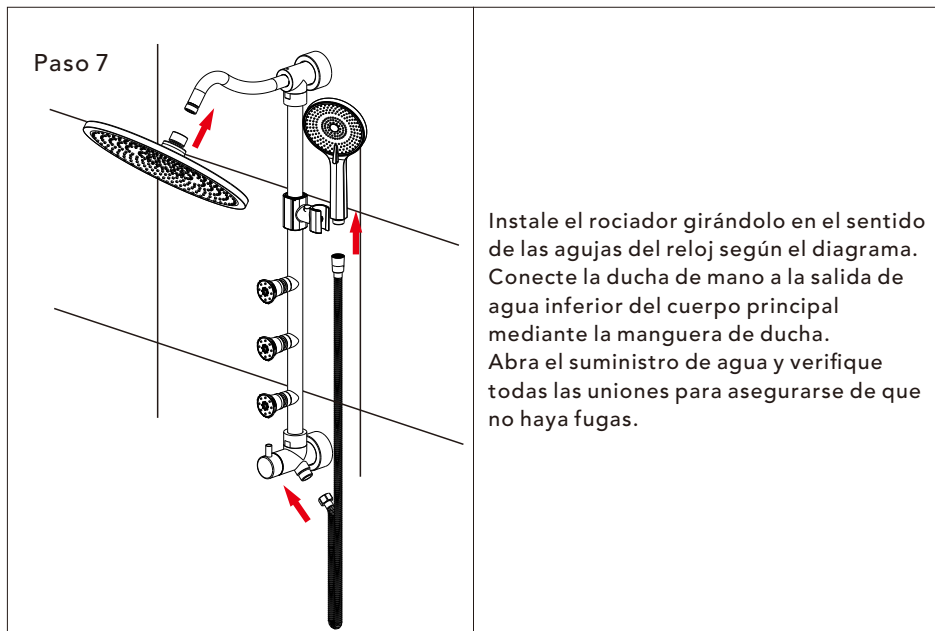

## ◆ Instrucciones de funcionamiento

