

# Assembly instruction

---

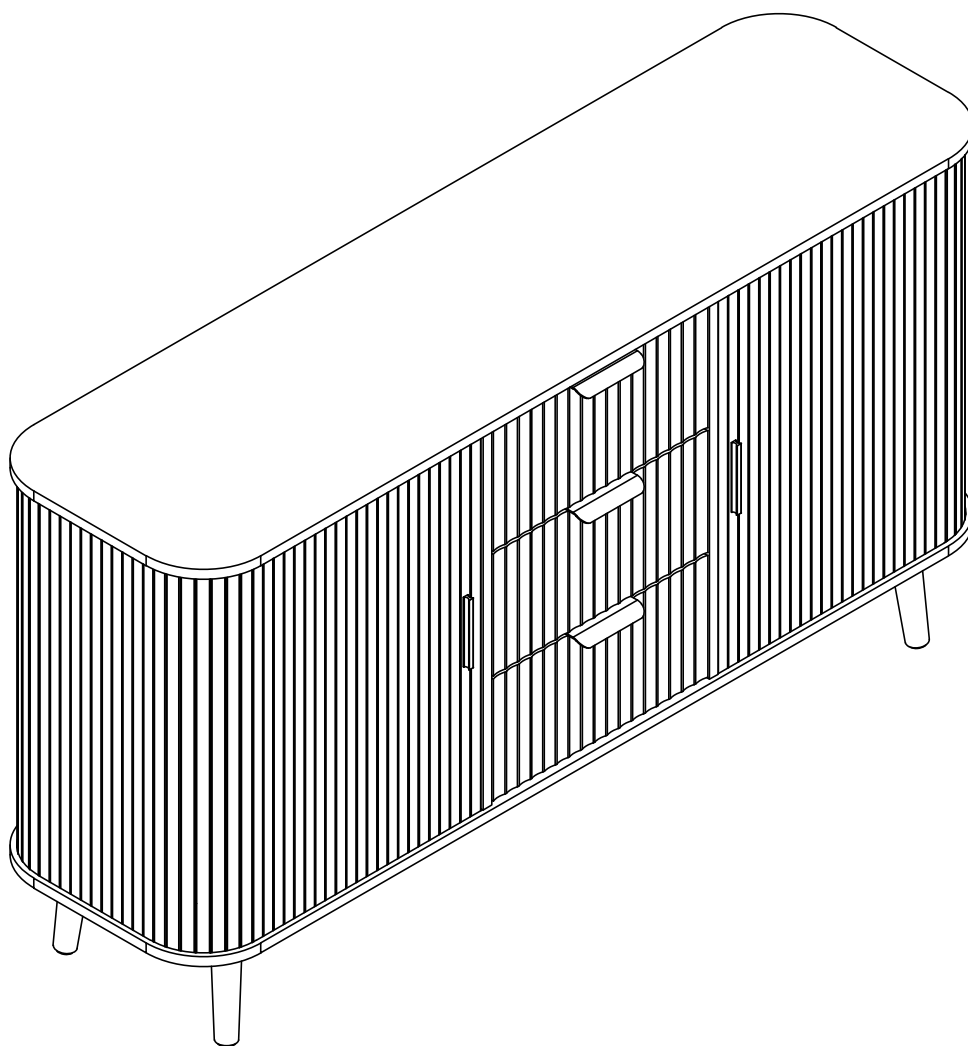

**Sideboard**

VIPService68@outlook.com

# Before You Start

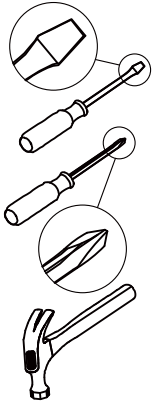

- ✓ Read through each step carefully and follow the proper order
- ✓ Separate and count all your parts and hardware, If Parts are missing defective or having wrong parts in package, or Board Surface is broken, scratched or lack of some screw holes. You can contact us and we will get back to you within 24 hours. Or, you can reach us via after-sales email.
- ✓ Give yourself enough room for the assembly process
- ✓ Caution: If using a power drill or power screwdriver for screwing, please pay attention to slow down and stop when screw is tight. Failure to do so may result in stripping the screw. ( Assembly speed can be increased by using electric screwdriver )

# Helpful Hints

## PEOPLE NEEDED FOR ASSEMBLY: 2

- Open your item in the area you plan to keep it to avoid excessive heavy lifting.
- Identify, sort and count the parts before attempting assembly.
- Do not make the screws too loose or too tight.
- The accessory bag contains some small accessories, which should be kept away from children.
- The remaining parts are spare parts.
- Do NOT use harsh chemicals or abrasive cleaners on this item. And Never push, pull, or drag your furniture.
- Young children can be seriously injured by tipping furniture. You must install the tipping restraint hardware with the unit ( No. 1 ) to prevent the unit from tipping, causing any accidents or damage. the tipping restraints are intended only as a deterrent, they are not a substitute for proper adult supervision.



# Product Installation Video

Please scan this QR code with your cell phone YouTube to watch the installation video instantly.



## Need Help With Your Furniture?

When missing parts? Or feeling stuck? you can contact us by scanning the QR code below or via after-sales email ([VIPService68@outlook.com](mailto:VIPService68@outlook.com)), we will reply you in time.

**FREE REPLACEMENT  
PARTS AVAILABLE!**









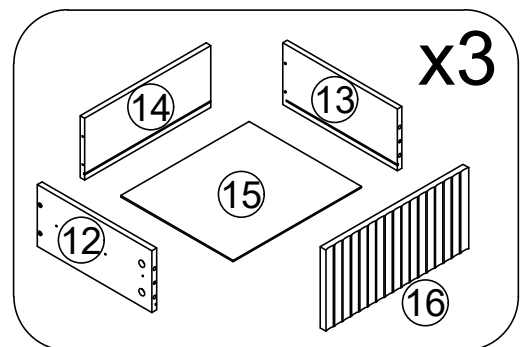
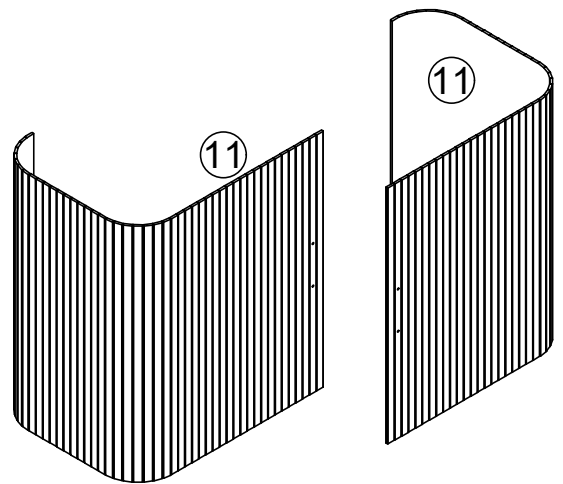
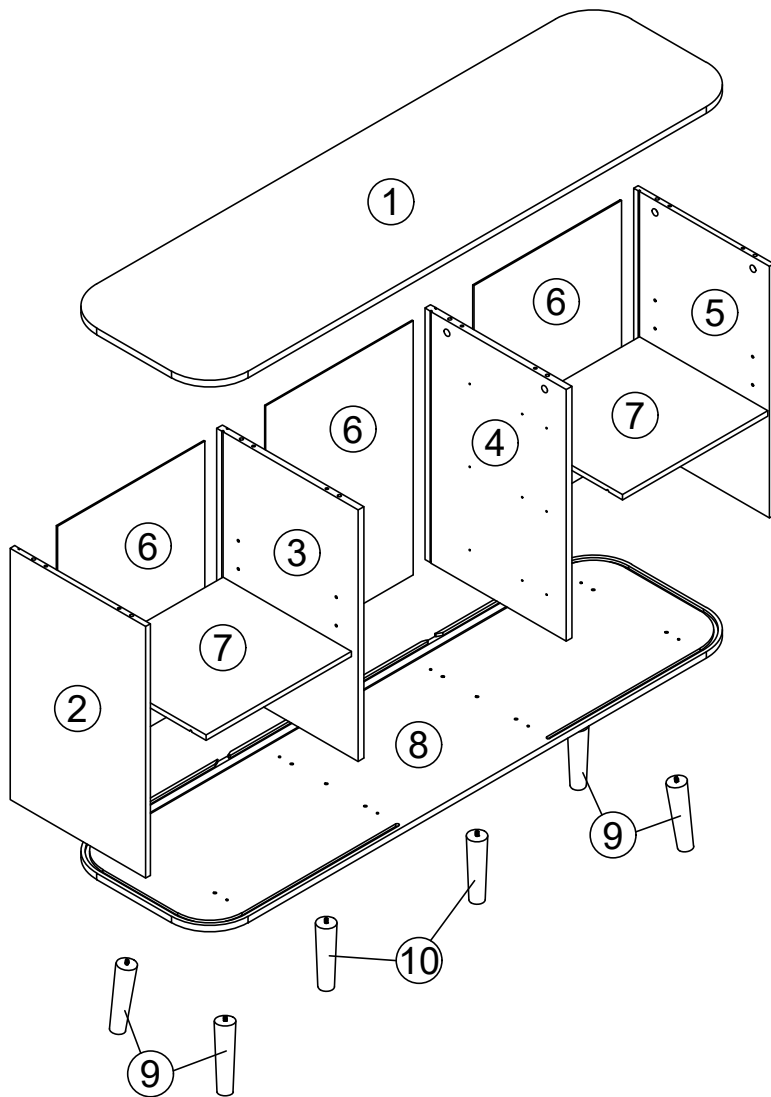



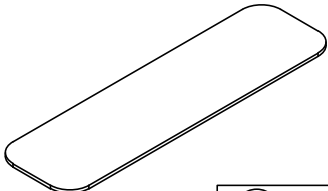
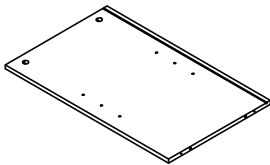
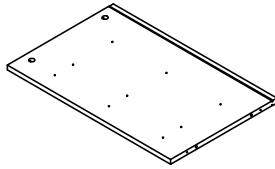
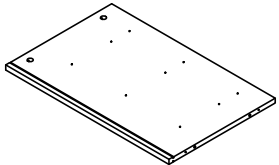
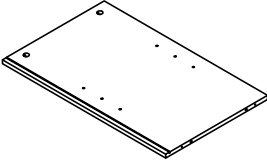
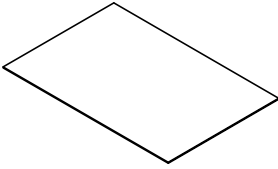
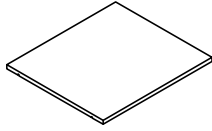
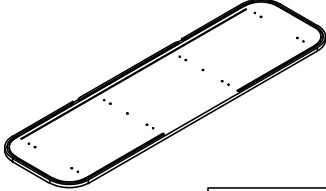
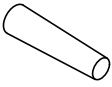
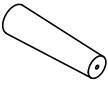
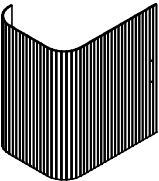
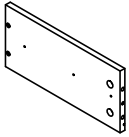
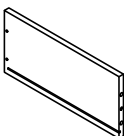
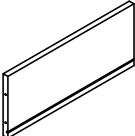
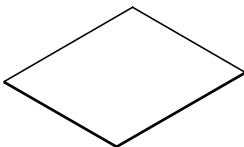
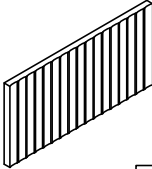
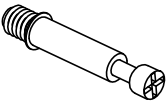

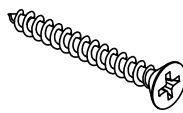
# This Is A Challenge For You !

Putting furniture together can feel tricky at first,  
but why not give it a shot?

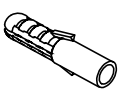
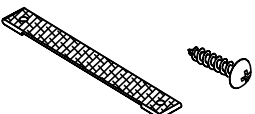
Once you' re done, you' ll see it' s not as hard as it looks  
—and your family or friends might even be impressed!

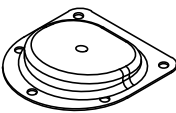

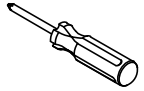
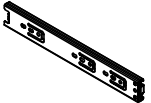
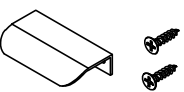
# PartsList / TeileListe

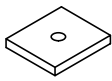
 ① x1	 ② x1	 ③ x1	 ④ x1	
 ⑤ x1	 ⑥ x3	 ⑦ x2	 ⑧ x1	
 ⑨ x4	 ⑩ x2	 ⑪ x2	 ⑫ x3	
 ⑬ x3	 ⑭ x3	 ⑮ x3	 ⑯ x3	
<b>A</b>  20(+2)PCS	<b>B</b>  20(+2)PCS	<b>C</b>  22(+2)PCS	<b>D</b>  22(+2)PCS	<b>E</b>  36(+2)PCS
<b>F</b>  2PCS	<b>G</b>  12(+1)PCS	<b>H</b>  2PCS	<b>I</b>  2PCS	<b>J</b>  4PCS
<b>K</b>  4PCS	<b>L</b>  4PCS	<b>M</b>  20(+1)PCS	<b>N</b>  2PCS	<b>O</b>  1PC
<b>P</b>  6PCS	<b>Q</b>  3PCS	<b>R</b>  8PCS	<b>S</b>  1PC	

## How the knock down assembly system works

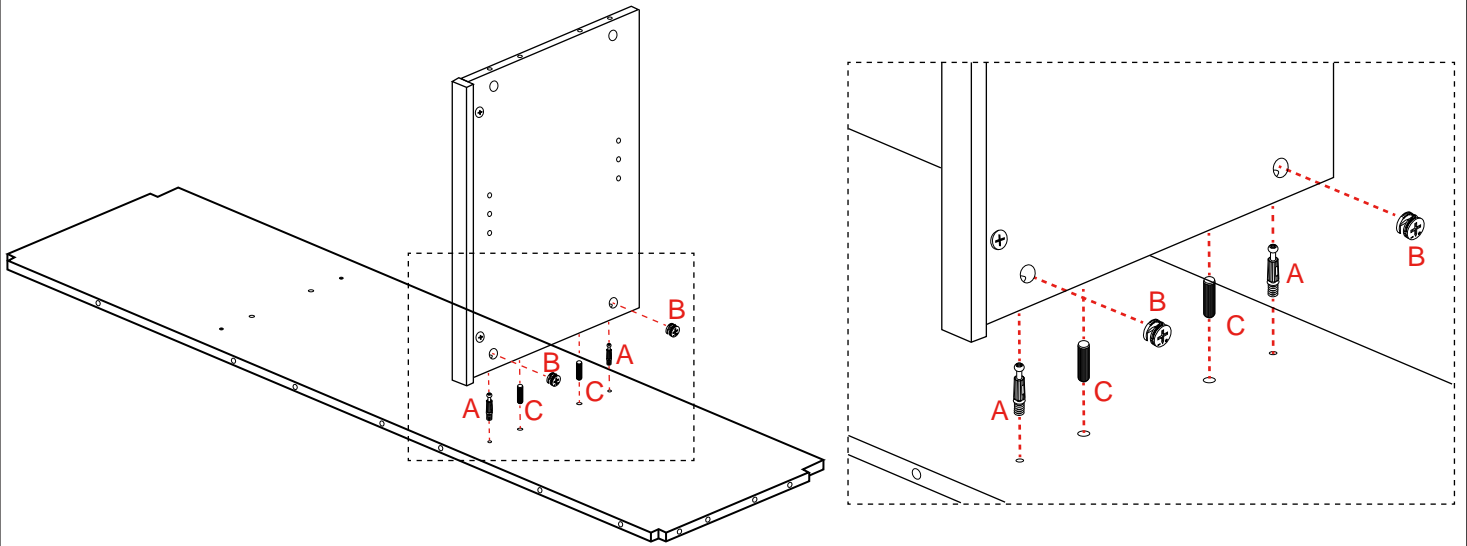

## How to Install Wood Dowel

Insert the wood dowel [ C ] at least half way by tapping lightly with a rubber mallet, IF NECESSARY.

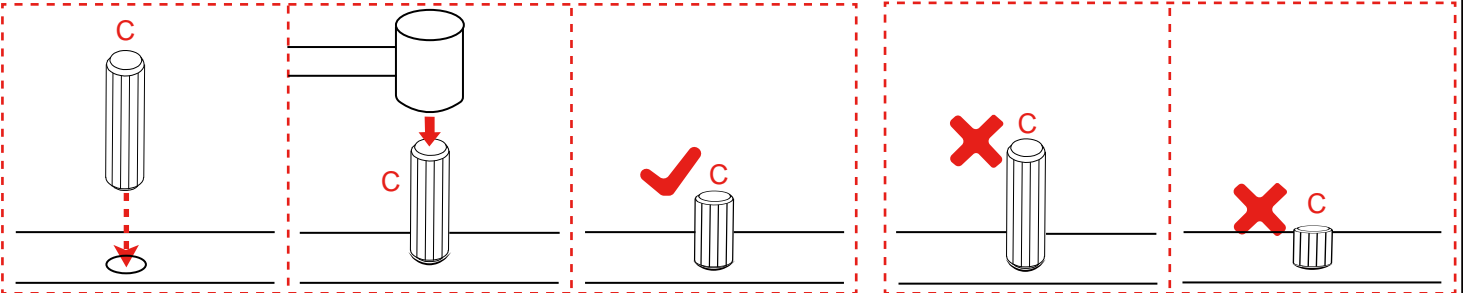

## Cam Lock System Operation

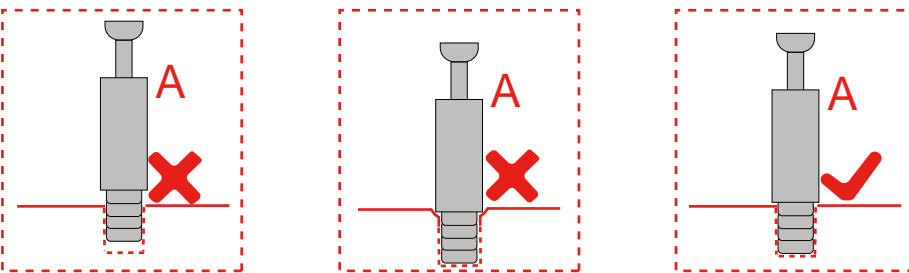

1. Screw the cam bolt [A] into the threaded insert on the panel.
2. Connect both panels together making sure cam bolt [A] goes into the pre-drilled large hole on the end of panel for cam lock [B].
3. Insert the cam lock [B] into the pre-drilled large hole on the panel. Make sure the cross slot of cam lock [B] faces out (The arrow should point towards Screw No. A).
4. Rotate the cam lock [B] clockwise with a self-supplied phillips screwdriver to lock the cam bolt [A] in place (Rotate 100-180 degrees until tight).

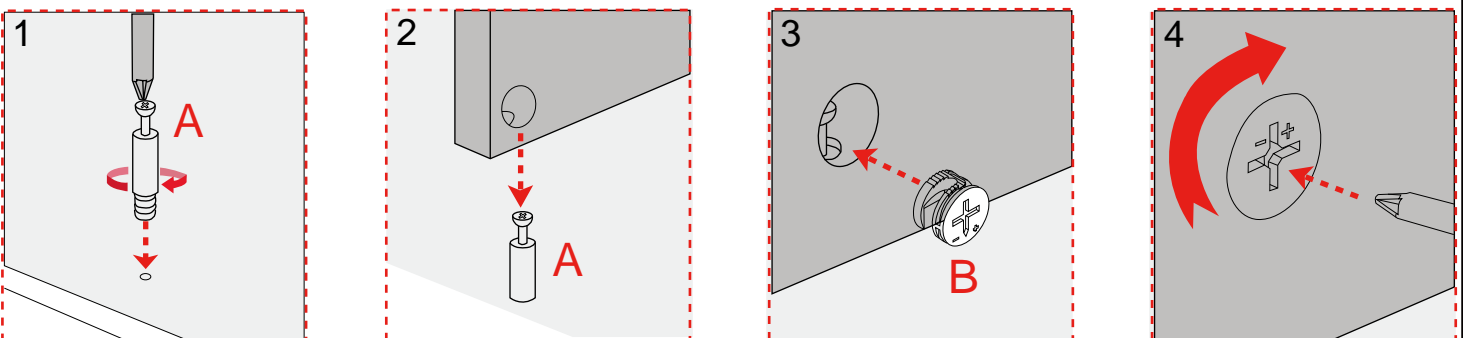

# STEP 1



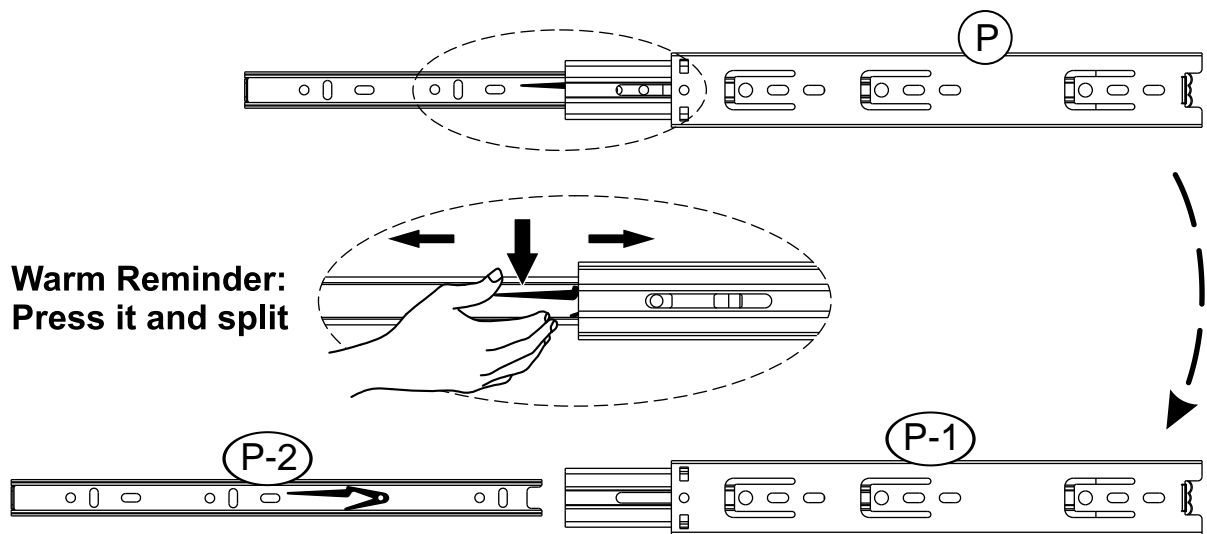

## Hardware installation demonstration

- Before installing the drawer rail you need to separate the P-1 and P-2 first.

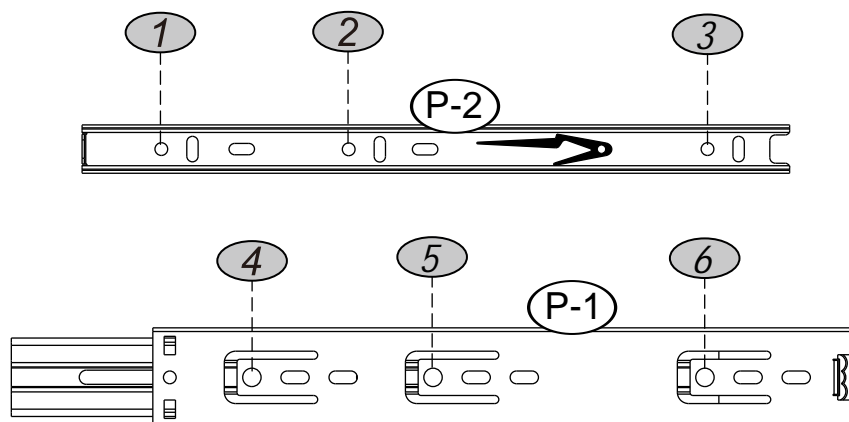

When assembling, the holes used for fixing the screws are marked as follows:



 The guide rails have been lubricated before leaving the factory to ensure smooth sliding of the drawer and extend its service life. This is normal.

# STEP 2

Use 18Pcs No. E screws to install the No. P-1 rail into the corresponding holes on Panels No. 3 and No. 4. (Please refer to the screw position diagram and the front view diagram.)

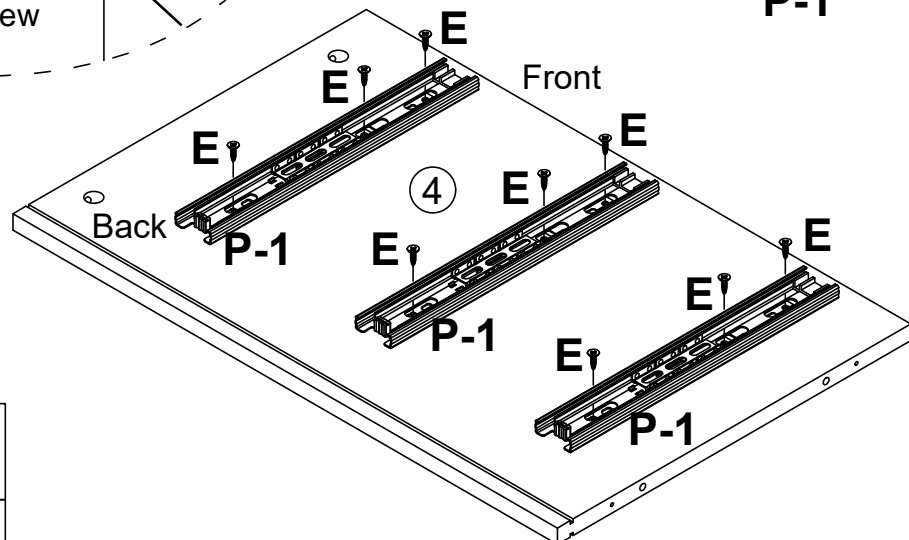
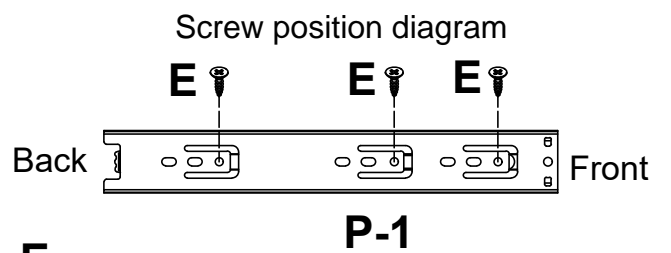
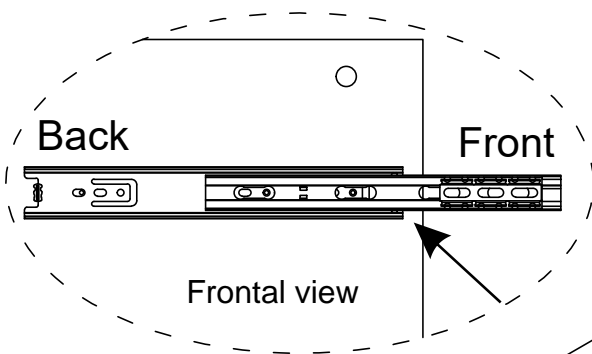
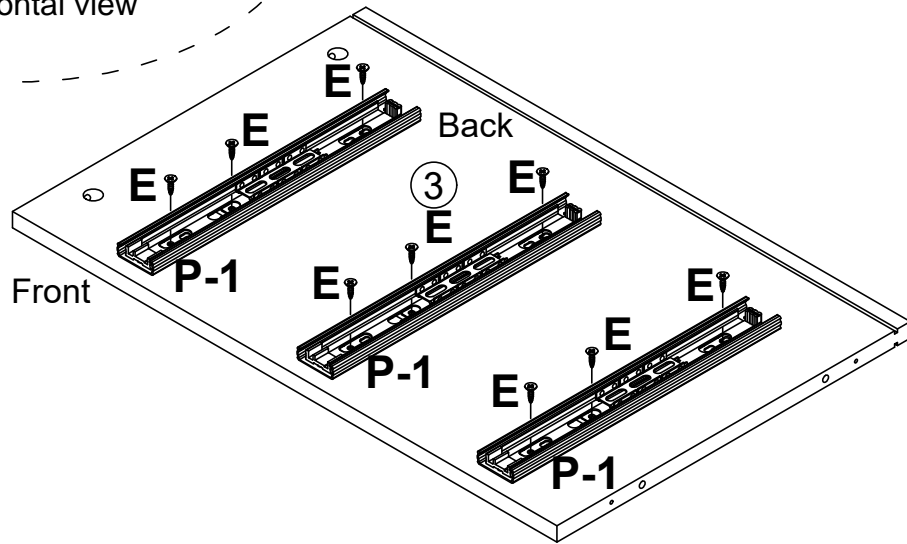
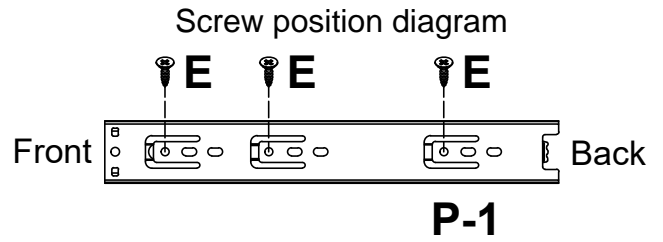
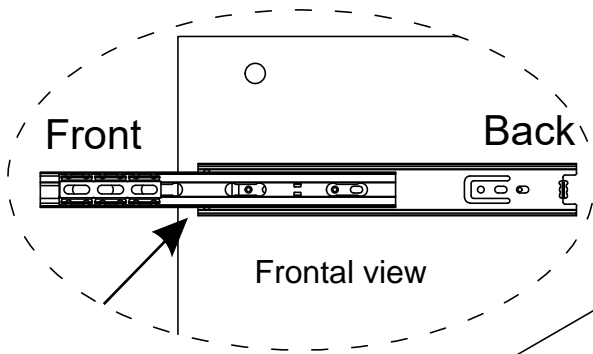

**E\*18**

**P-1**

**P\*6**

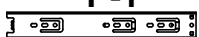

## STEP 3



# Preparation before installation

Please apply wax evenly in the grooves of Panel No. 1 and Panel No. 8. This will help the cabinet door slide out more smoothly. During use, wax fragments may come off, but this will stop after a short period of use.

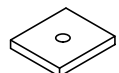
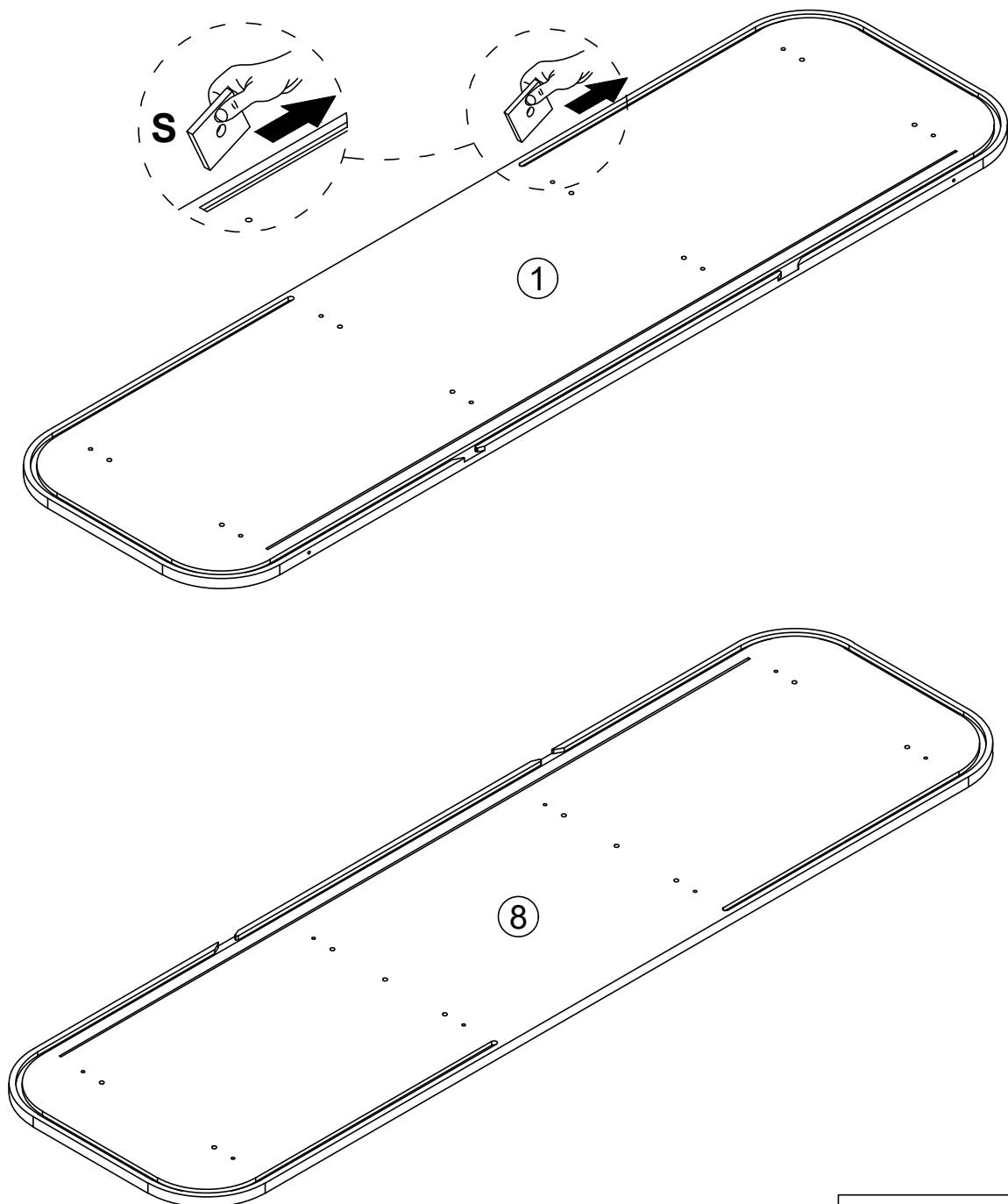

**S\*1**

## STEP 4

Install 8Pcs No. A screws into the corresponding holes on Panel No. 1. (Before installation, please check whether the groove of Panel No. 1 has been lubricated with the No. S wax block. If not, please refer to Step 3.)

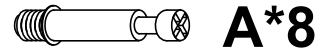
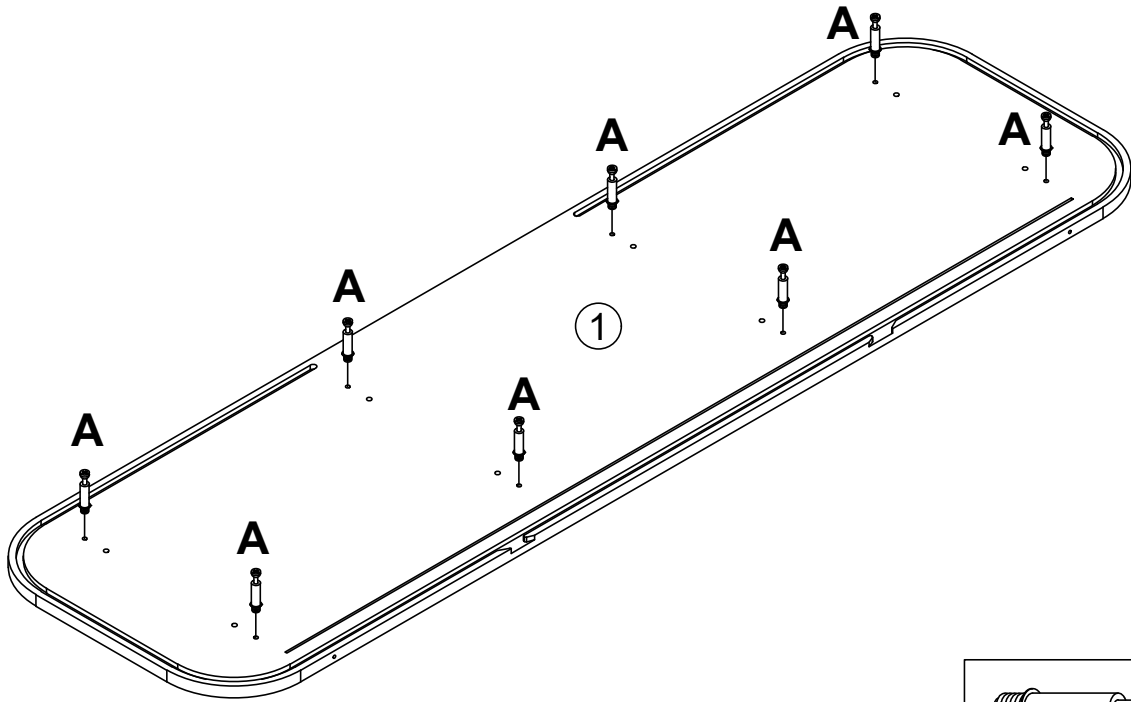

## STEP 5

First, insert 8Pcs wooden dowels into the holes on the sides of Panels No. 2, No. 3, No. 4, and No. 5, then use 8Pcs No. B screws to connect them to Panel No. 1. Please pay attention to the direction of each panel during installation.

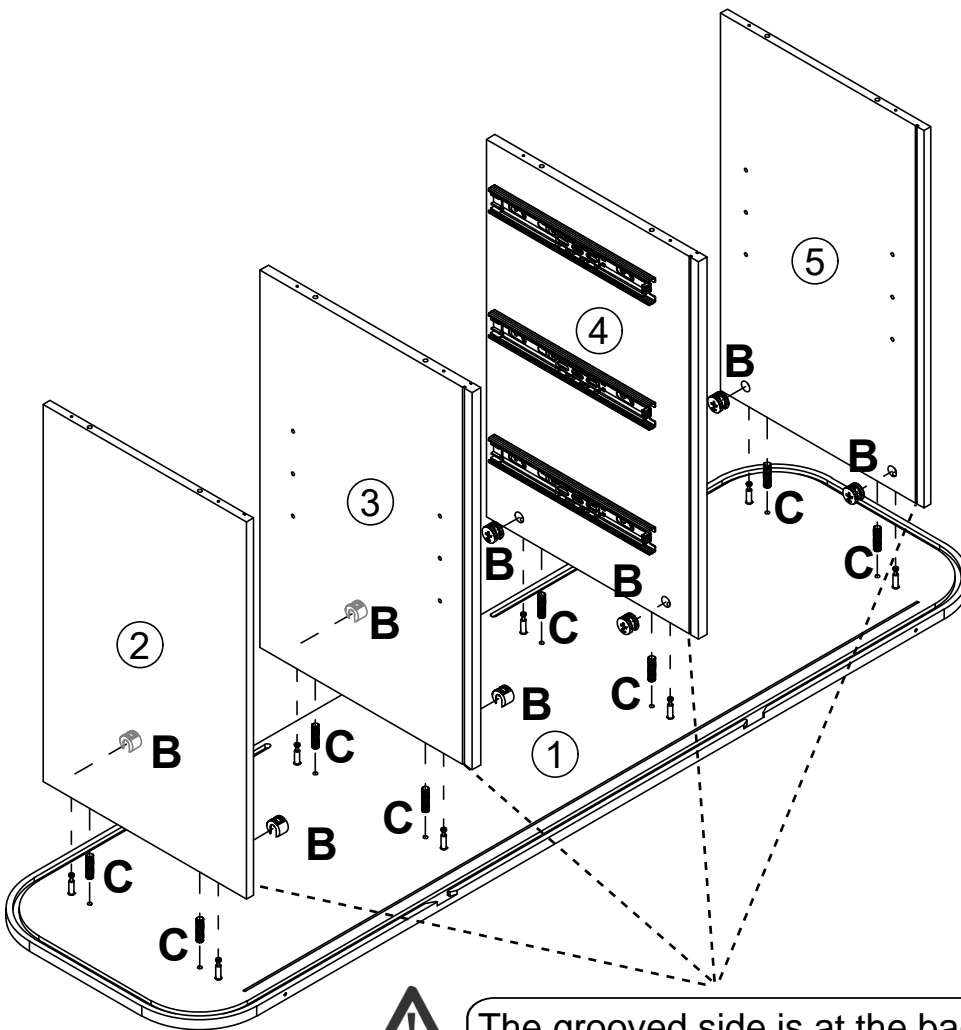

B\*8



C\*8

## STEP 6

First, insert 8Pcs No. C wooden dowels into the holes on the sides of Panels No. 2, No. 3, No. 4, and No. 5, then insert Panel No. 6 into the groove.

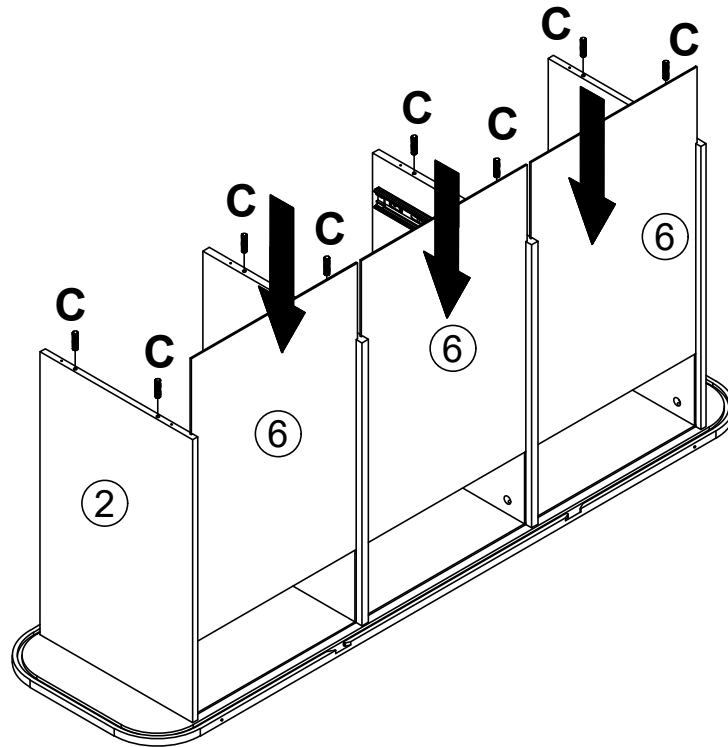

**C\*8**

## STEP 7

Use 8Pcs No. D screws to secure Panel No. 8 to the cabinet. When installing, please pay attention to the notes mentioned in the assembly steps.

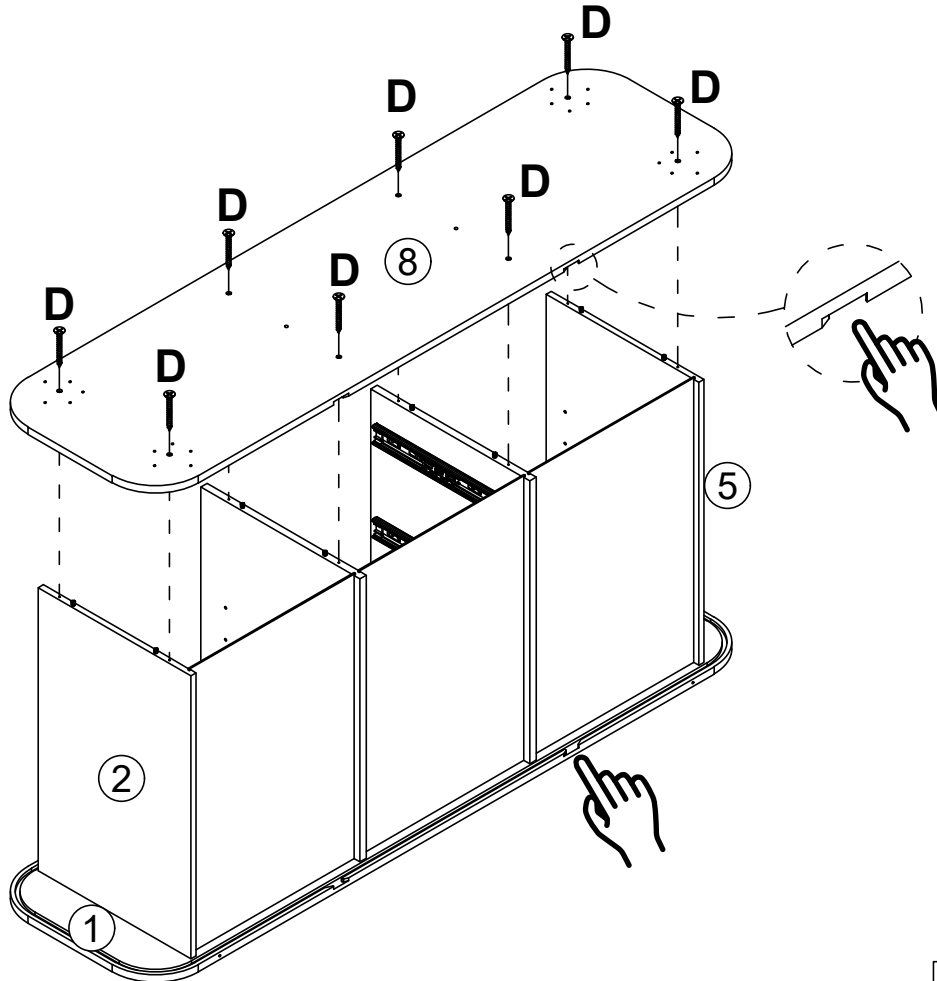

**D\*8**

**STEP 8** Use 20Pcs No. M screws to install the No. L metal plate on Panel No. 8.

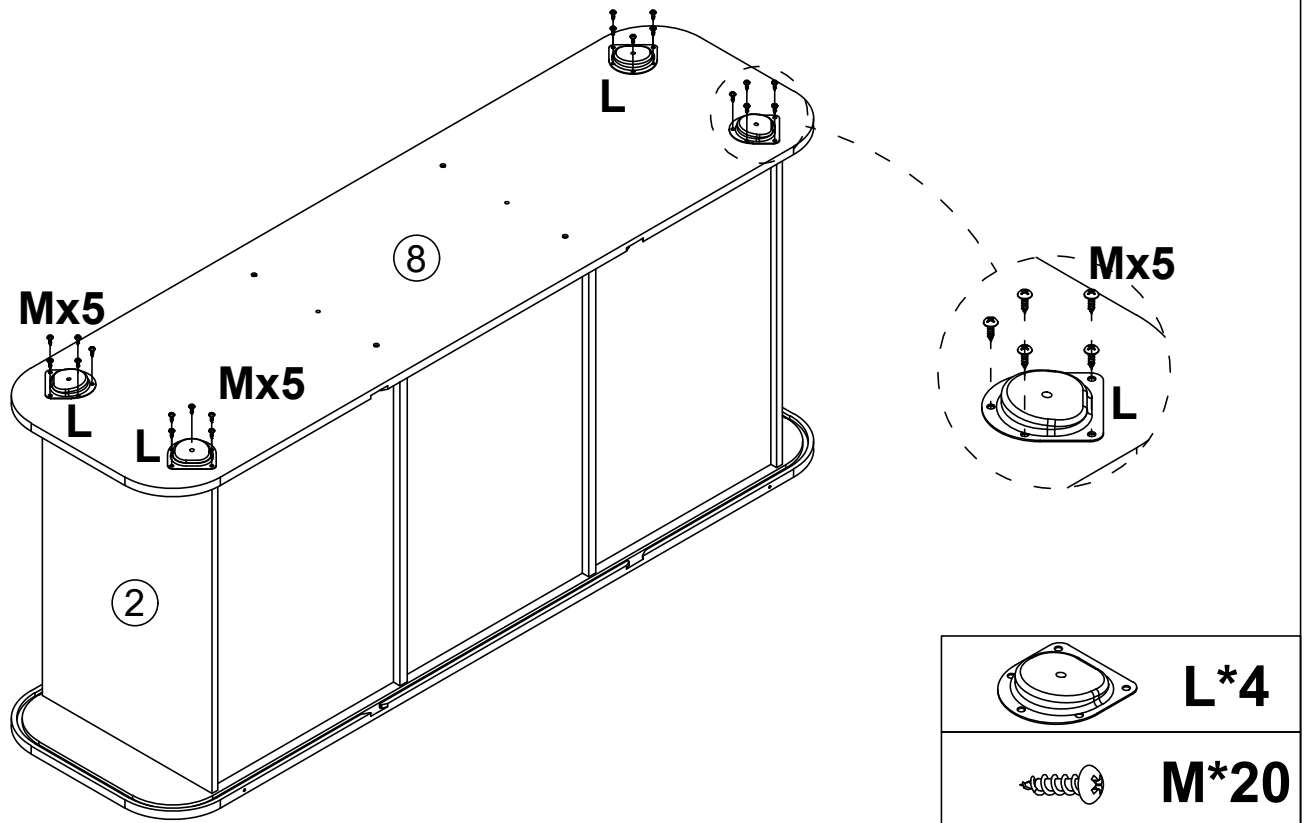

**STEP 9** First, install 4Pcs No. 9 support legs on the No. L metal plate, and attach the No. J anti-skid pads to the No. 9 support legs. Then install 2Pcs No. 10 support legs into the middle holes of Panel No. 8, and finally attach the No. N adjuster to the No. 10 support legs.

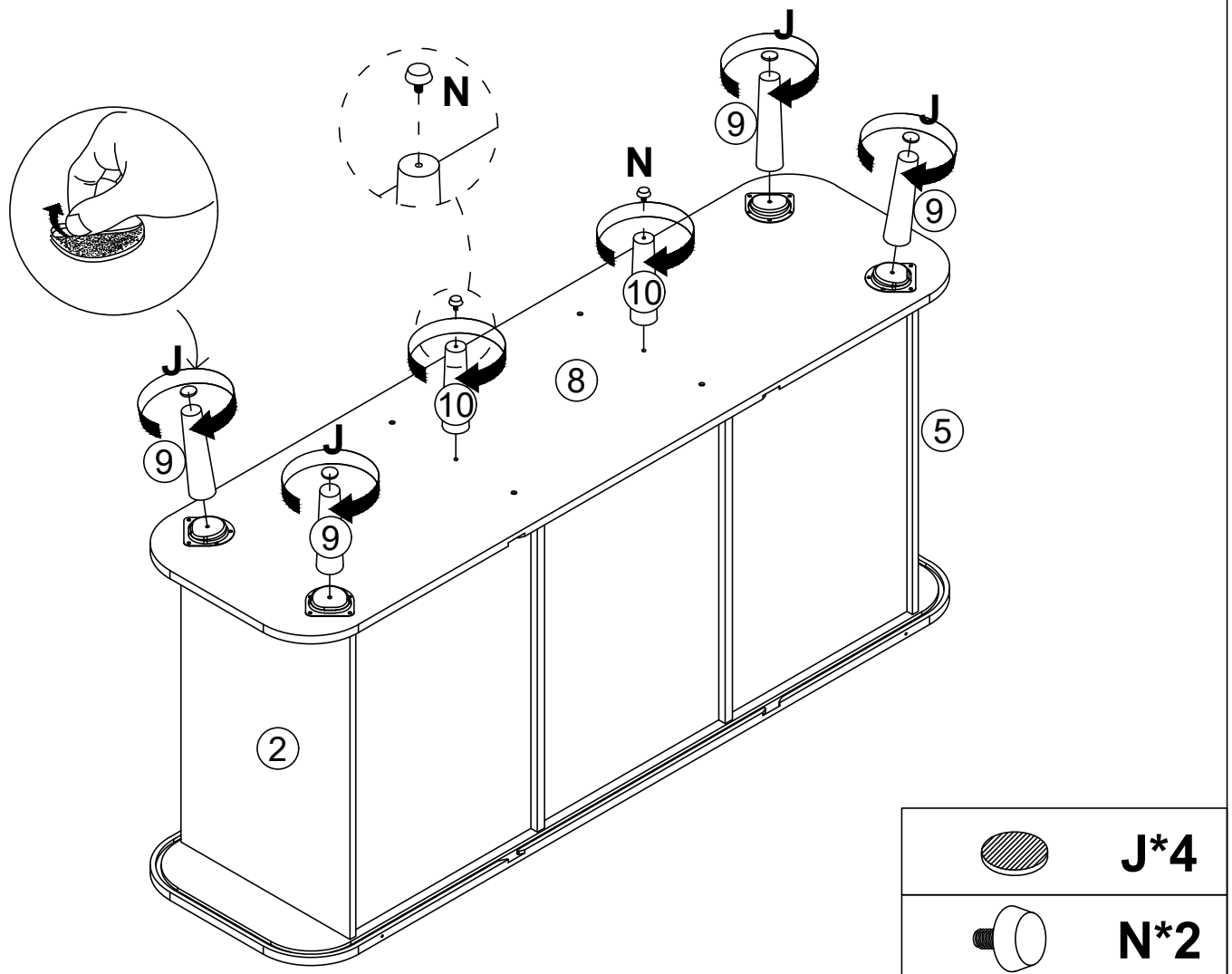

**STEP 10** Insert 8Pcs No. R shelf supports into the holes of Panels No. 2, No. 3, No. 4, and No. 5 (you can choose the appropriate height according to the items), then place Panel No. 7 on the shelf supports.

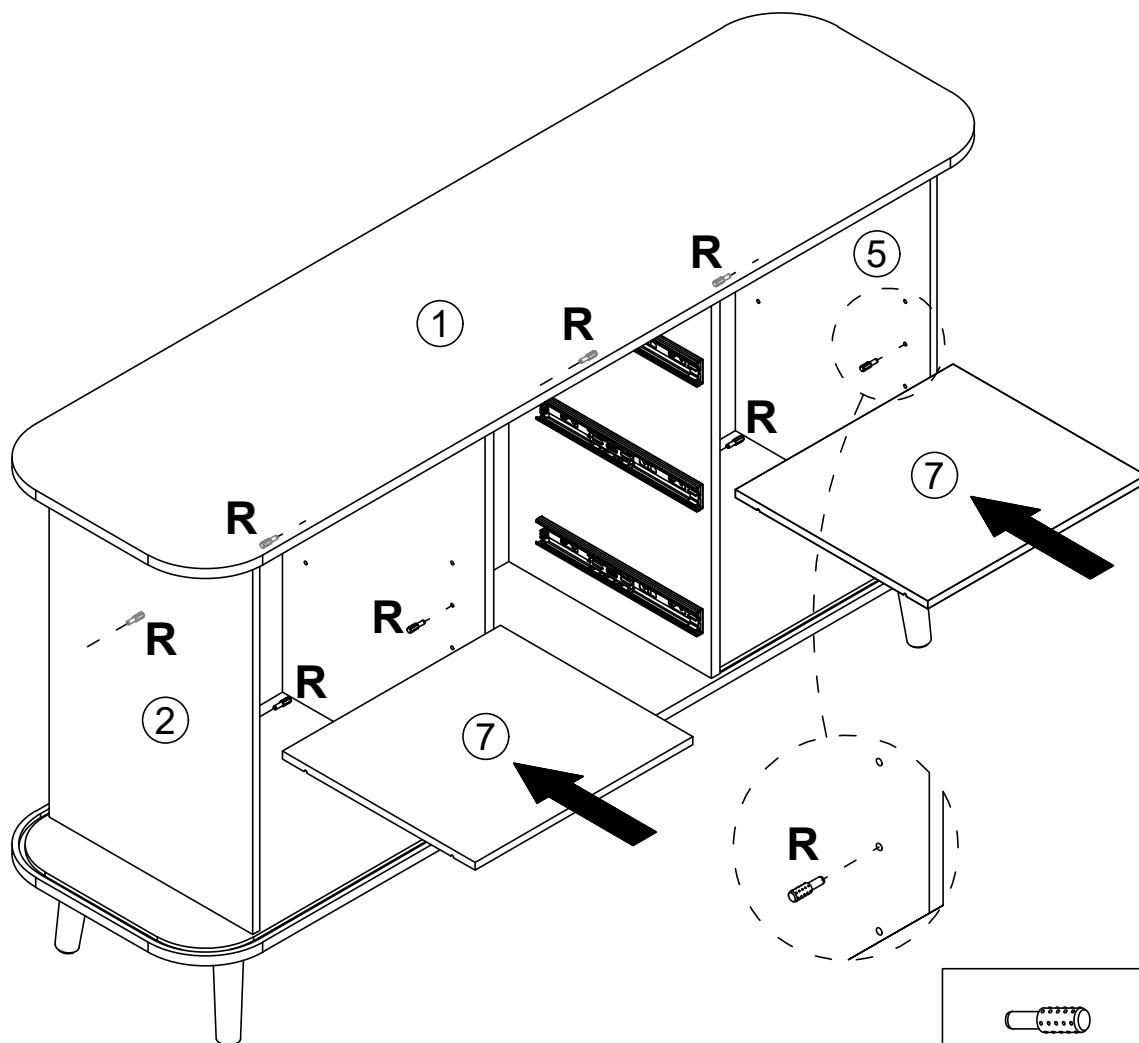

**R\*8**

**STEP 11** Use 4Pcs No. K screws to attach the No. F handle to Panel No. 11.

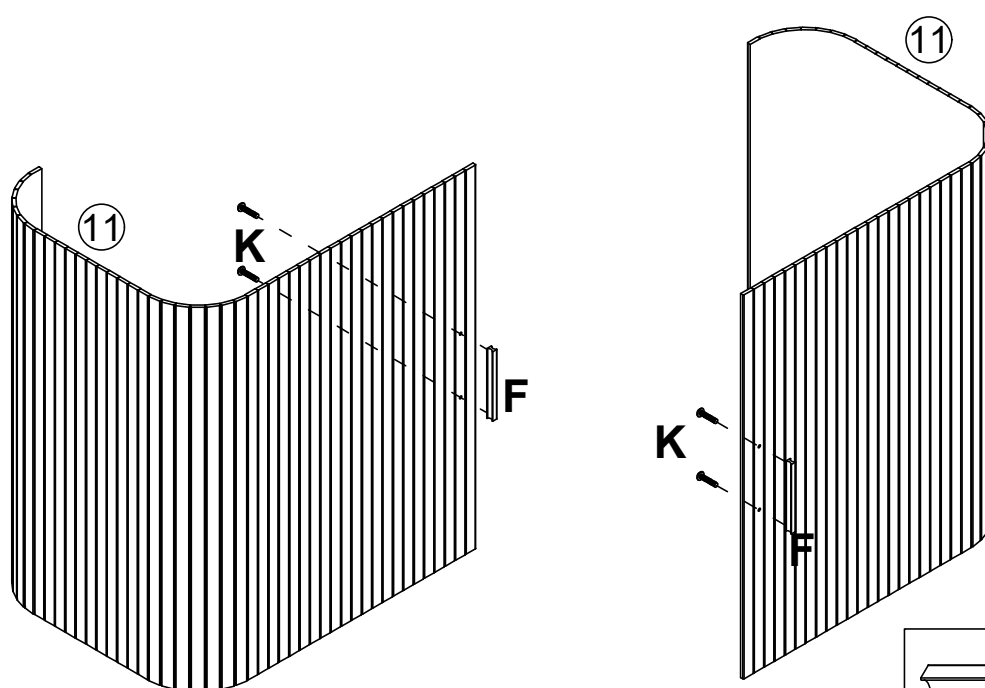

**F\*2**



**K\*4**

**STEP 12** Use 12Pcs No. G screws to install the back panel buckles in the positions shown in the picture . After installation, the cabinet will be more stable. Please make sure to install them. (The indicated positions are not pre-drilled.)

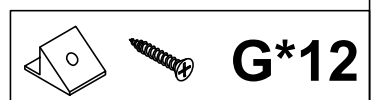
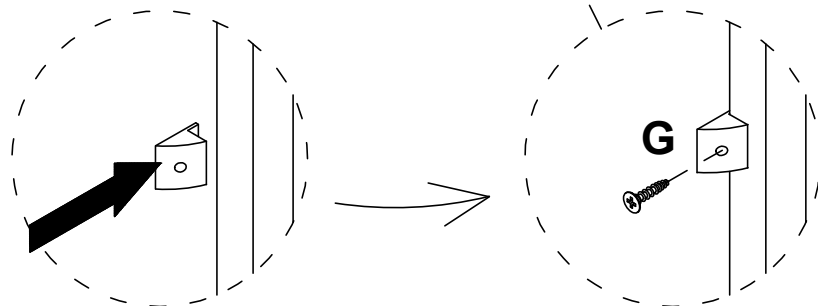
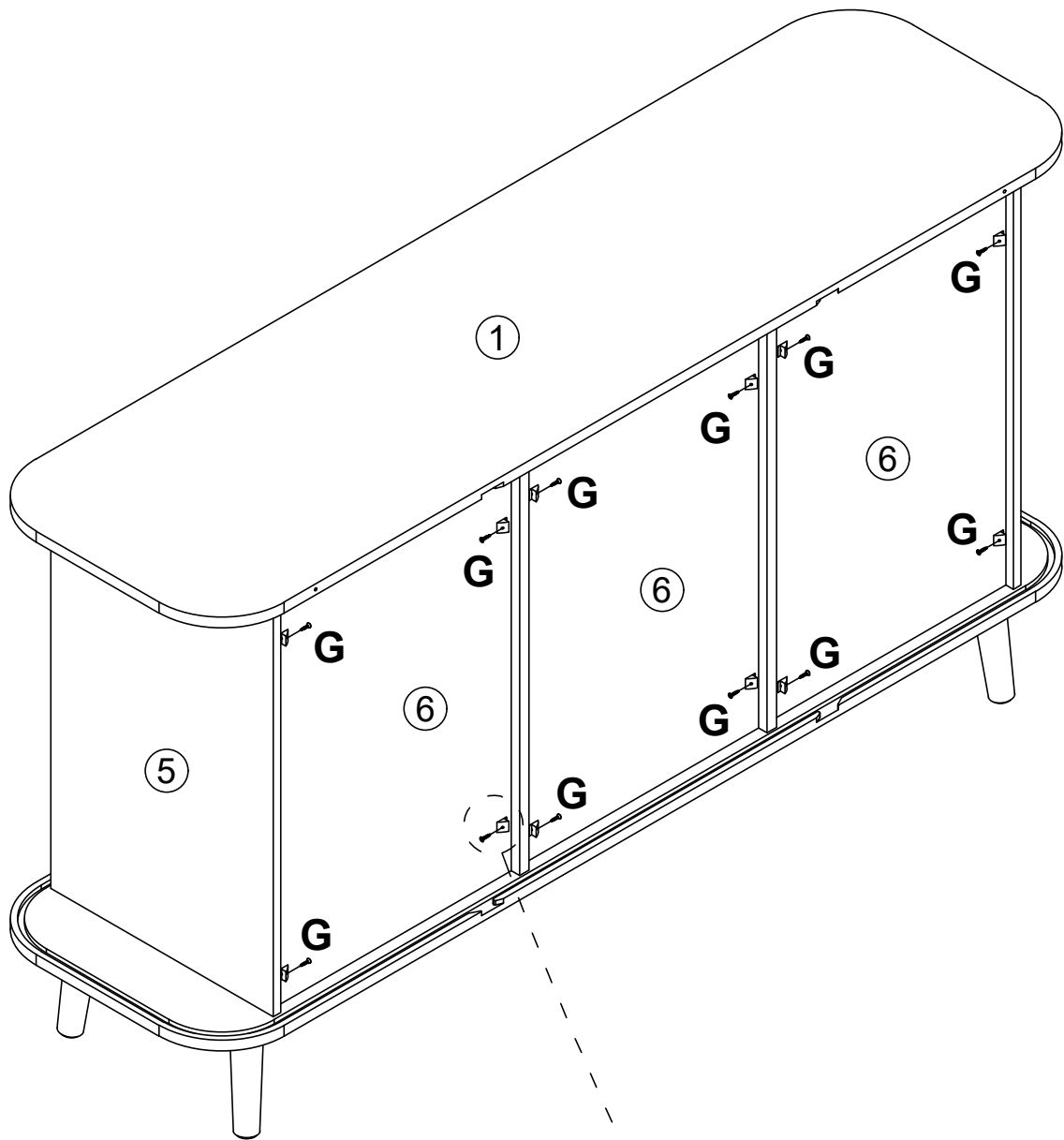

## STEP 13

Insert the No. 11 sliding door through the groove at the back of the cabinet into the groove on the left side (rear view). Make sure to insert the side with the handle into the groove first.

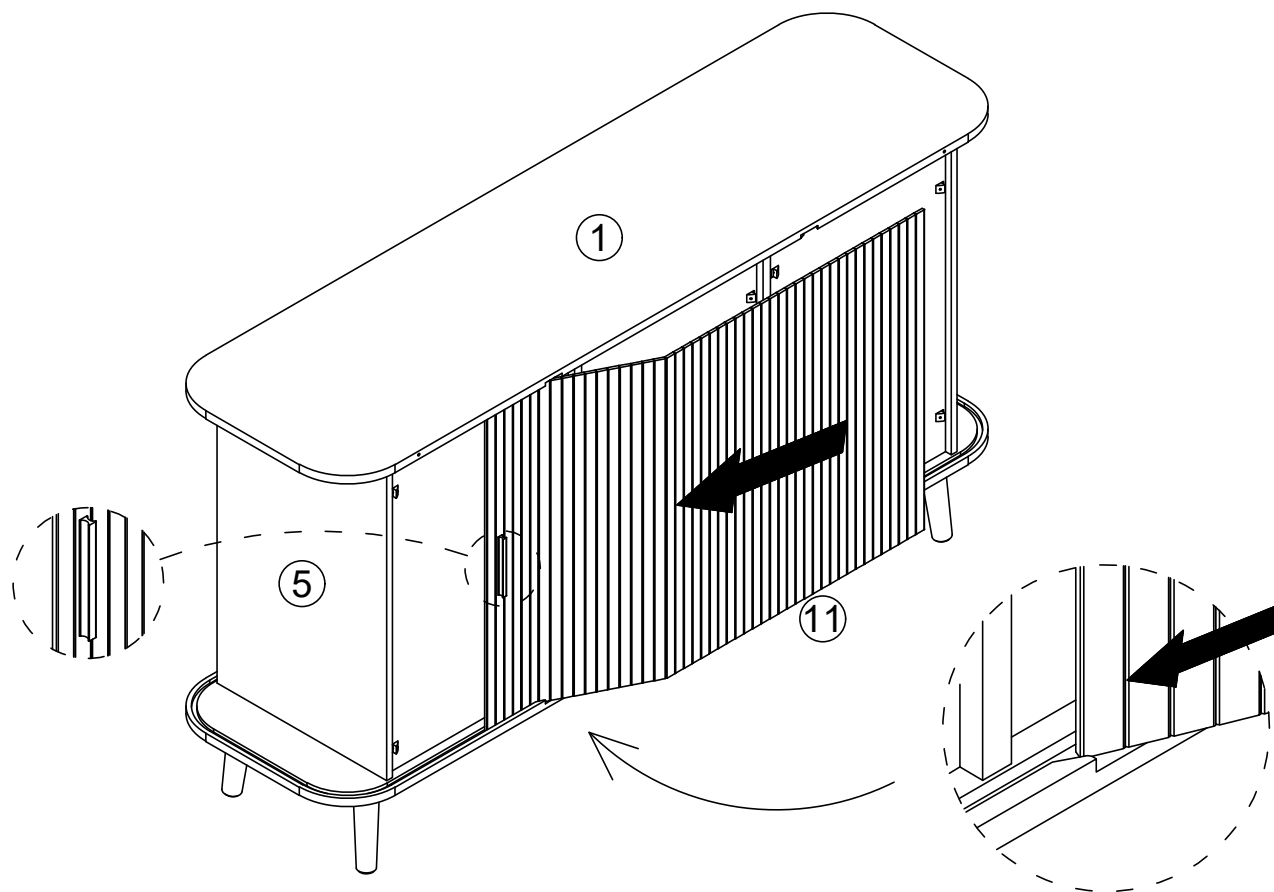

## STEP 14

Insert the No. 11 sliding door through the groove at the back of the cabinet into the groove on the right side (rear view). Make sure to insert the side with the handle into the groove first.

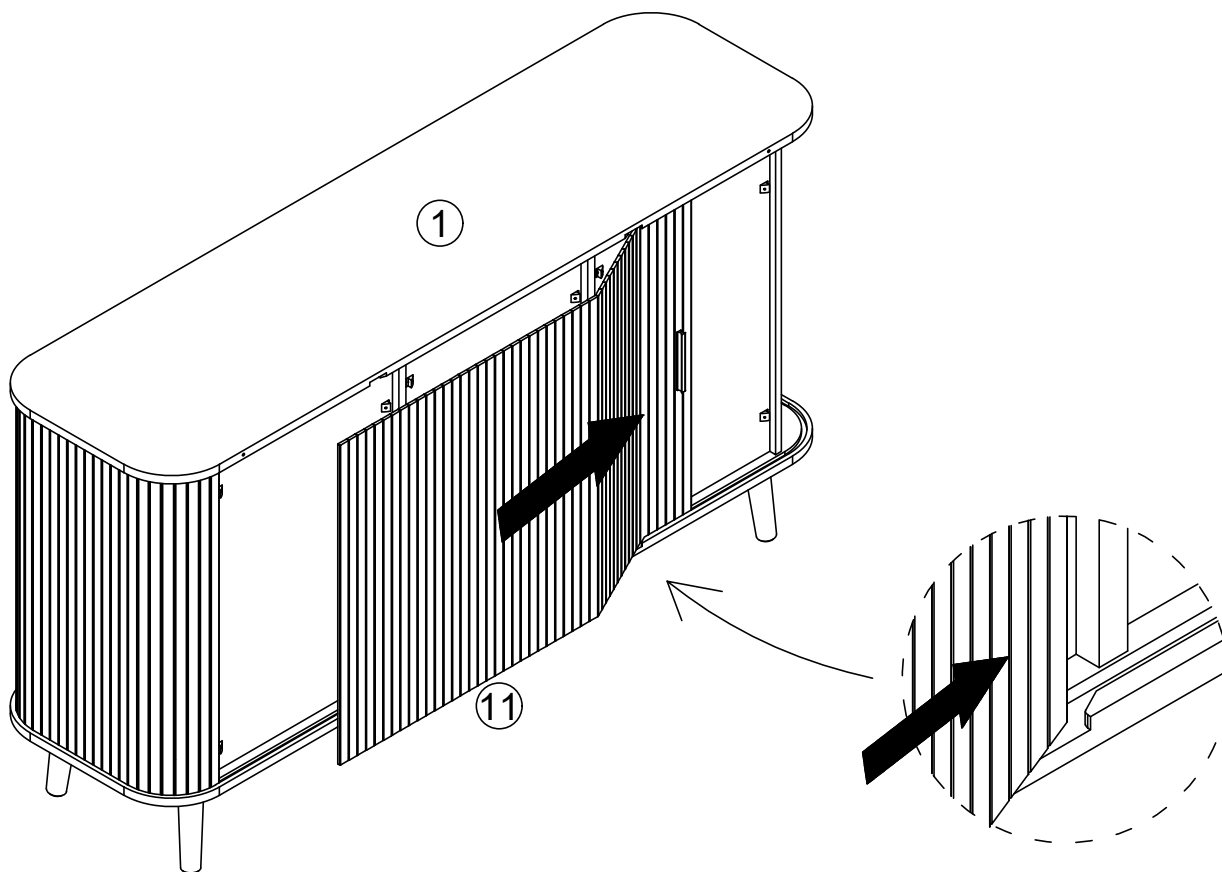

# STEP 15

Use 4Pcs No. D screws to connect Panels No. 12, No. 13, and No. 14, then insert Panel No. 15 into the grooves of Panels No. 12 and No. 13. Please note that there are 3 drawers that need to be assembled.

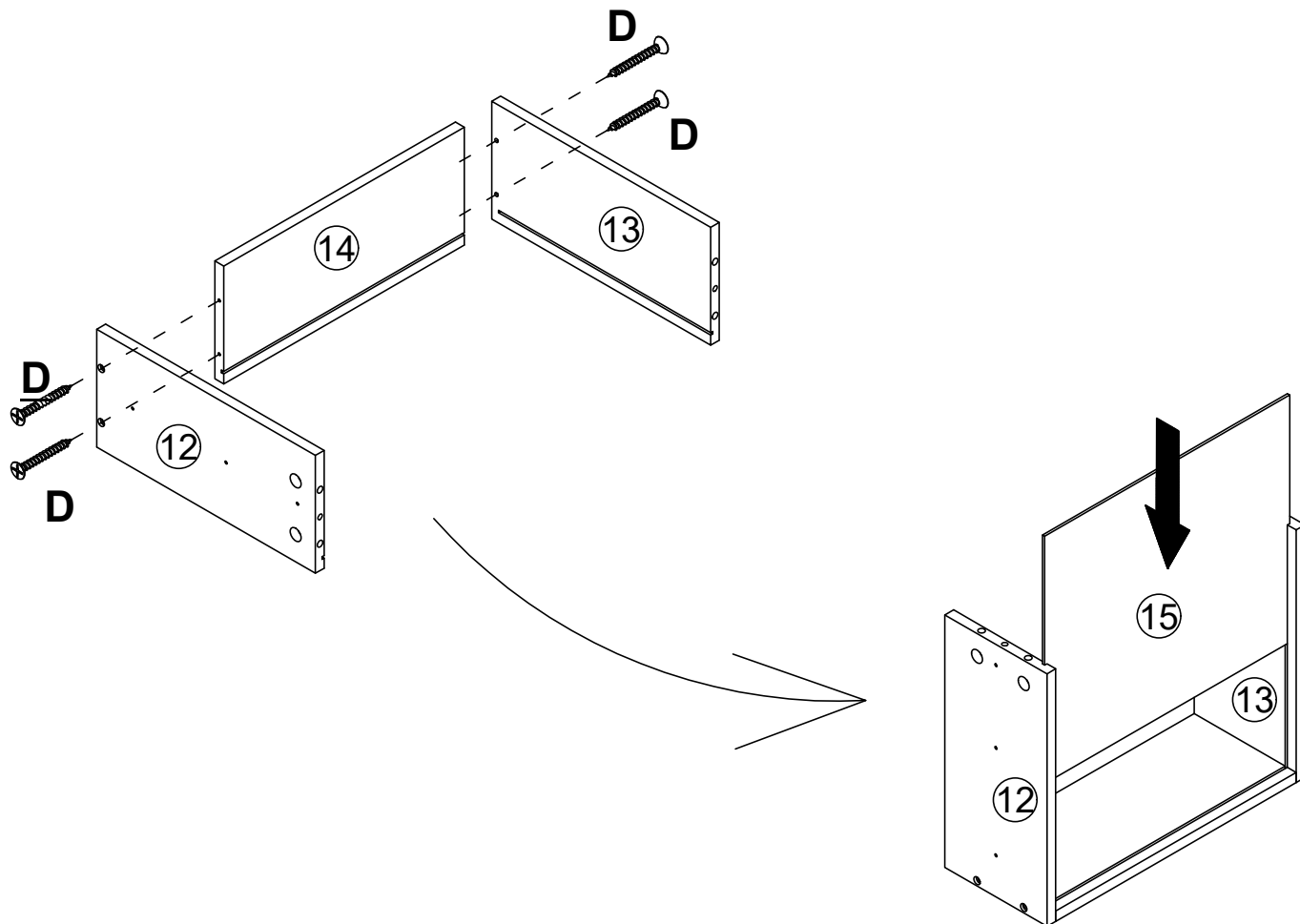

# x3pcs



**D\*12**

# STEP 16

Install 4Pcs No. A screws on Panel No. 16.

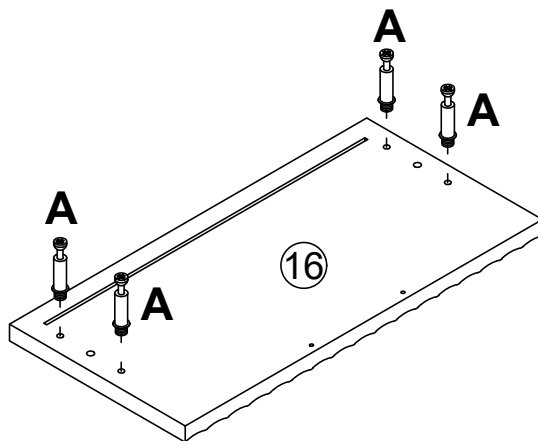

# x3pcs

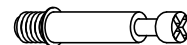

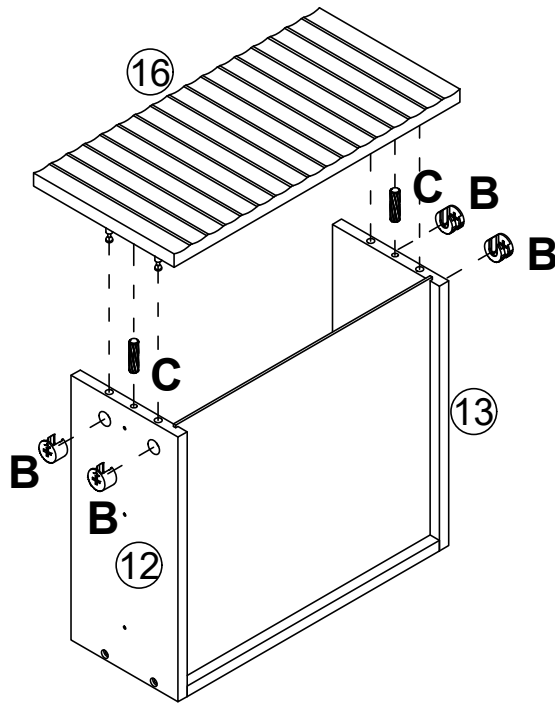

**A\*12**

**STEP 17** First, insert 2Pcs No. C wooden dowels into the holes on the sides of Panel No. 12 and Panel No. 13, then use 4Pcs No. B screws to connect Panel No. 12, Panel No. 13, and Panel No. 16.





x3pcs

	<b>B*12</b>
	<b>C*6</b>

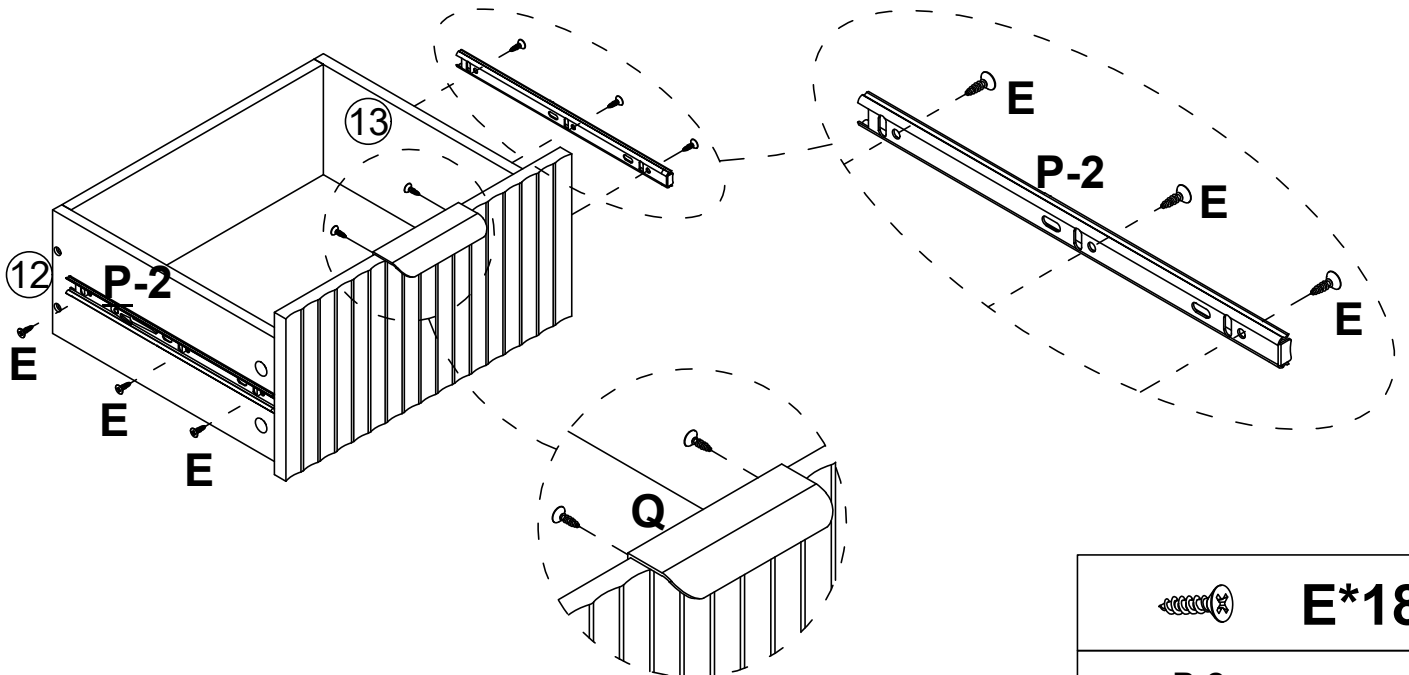
**STEP 18** First, use 6Pcs No. E screws to install the No. P-2 inner rail on Panel No. 12 and Panel No. 13, then use No. Q screws to install the handle on Panel No. 16.



x3pcs

	<b>E*18</b>
	<b>P*6</b>
	<b>Q*3</b>

# STEP 19

Note: When assembling the inner rail (No. P-2), first insert it into the plastic clip, then slide the inner rail (No. P-2) in parallel with the outer rail (No. P-1). Forcing it in may cause the rail balls to fall off or become deformed. If the rail is damaged, please contact us promptly, and we will provide a new one for **Free!**

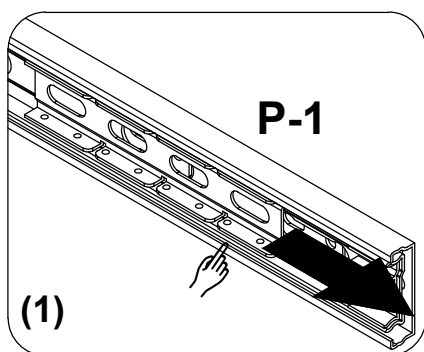
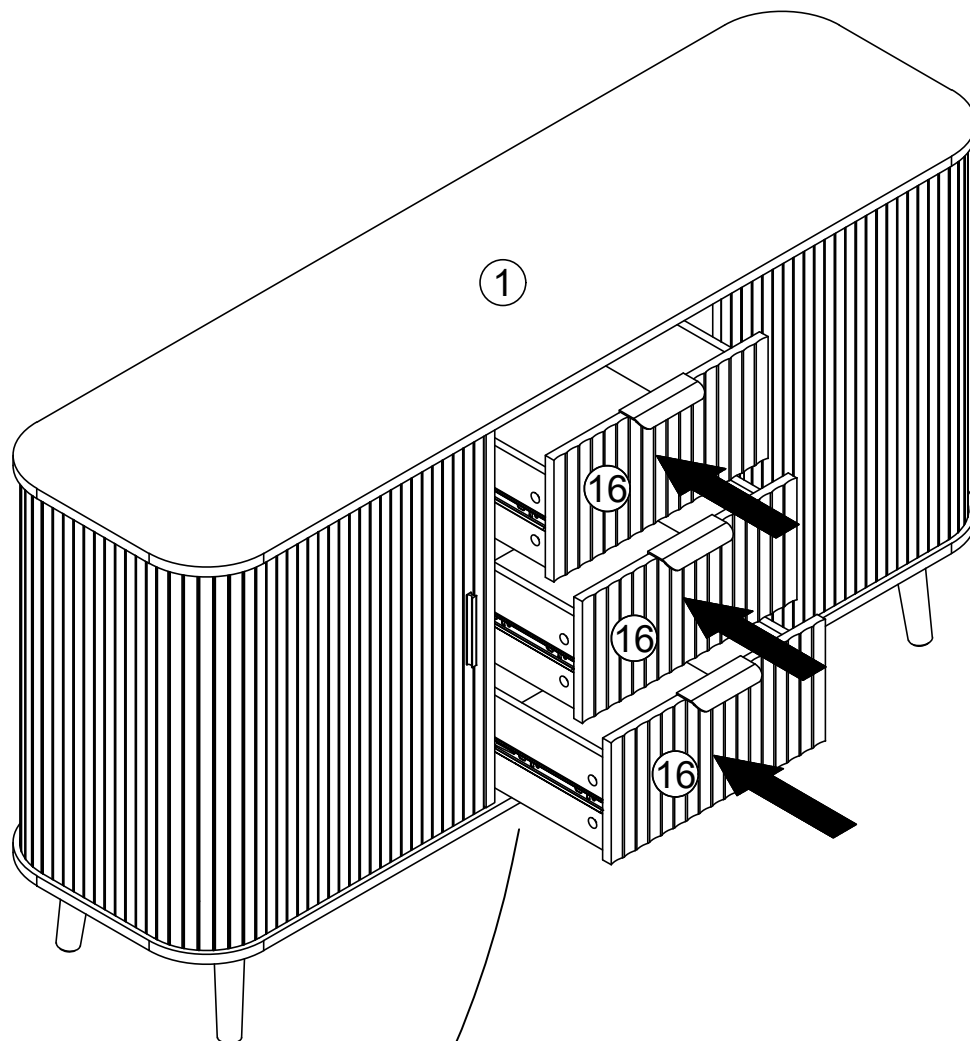

(1) Move the balls of the slide rails on both sides to the position as shown in the figure

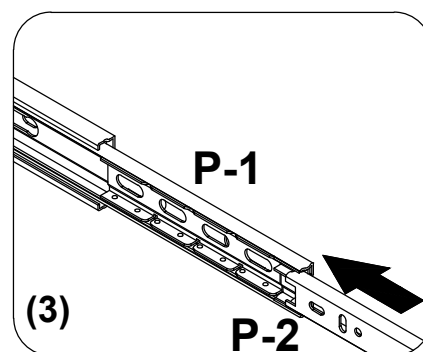
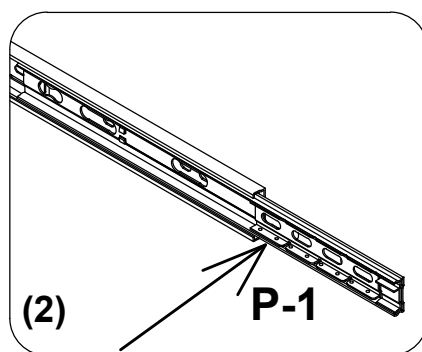

Slide rails on both sides are inserted into the slide groove at the same time

# STEP 20

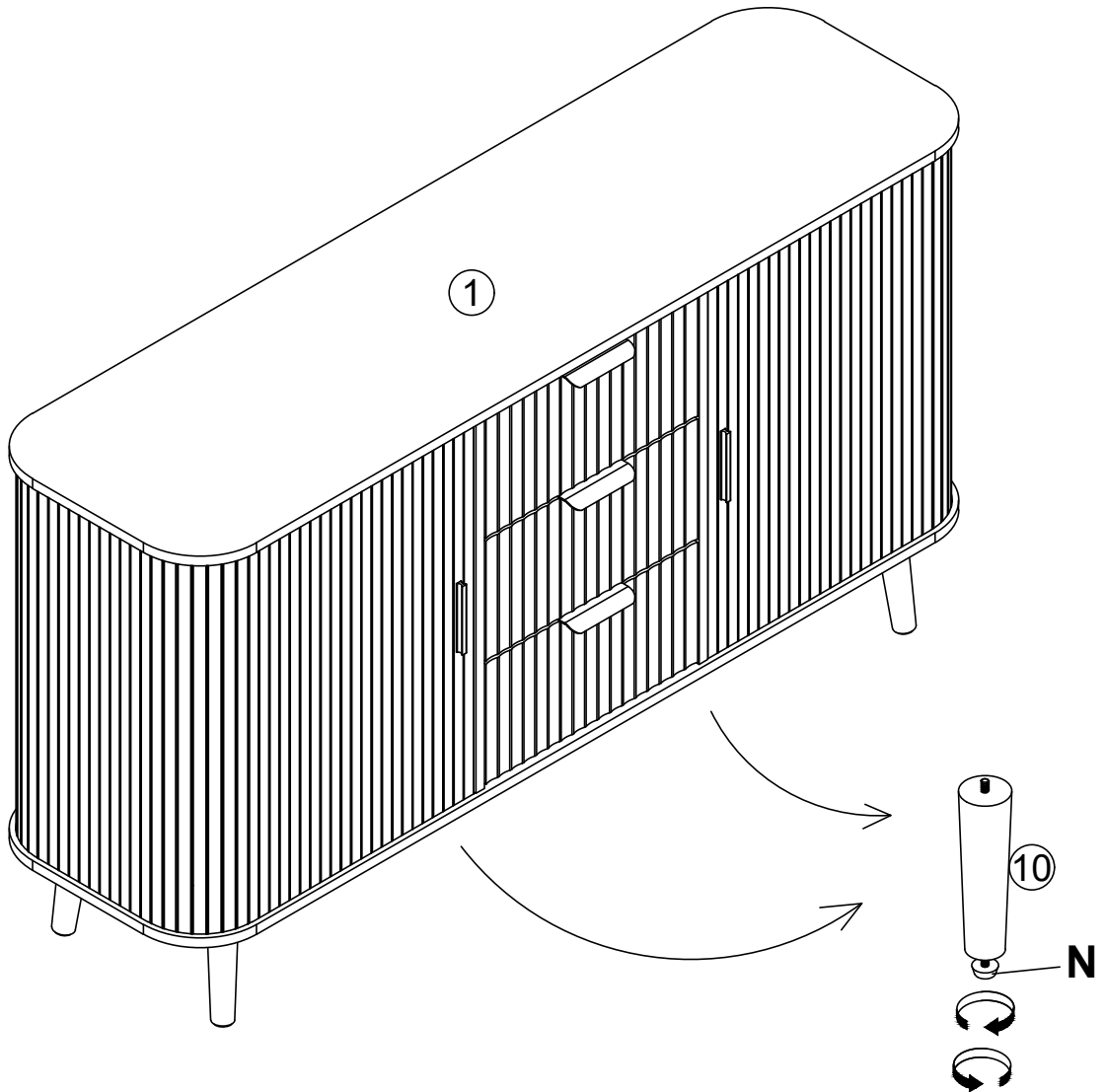

If the Cabinet is unstable with the ground, please rotate the adjusting foot pad (N) on plate 10.

# STEP 21

Install the anti-tip device to secure the cabinet to the wall. This will help prevent tipping, especially in households with children.

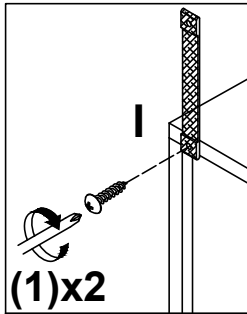

First fix the anti-rewind screw in the reserved hole of the product.

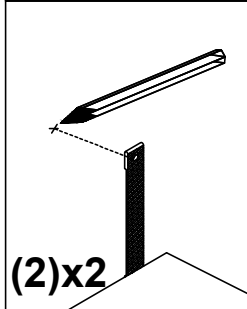

then, use a ruler to measure the approximate height of the product on the wall, and then mark it with a pen.

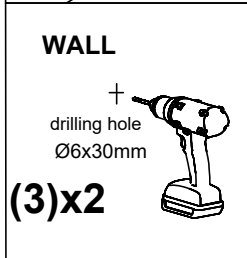

Then use a tape drill to make holes in the wall that are suitable for the product screws.

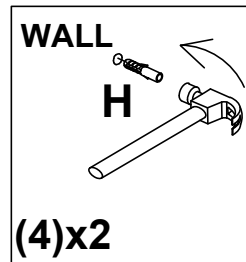



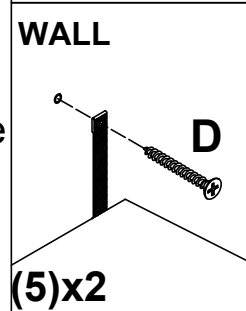

Then, put the expansion bolt into the hole

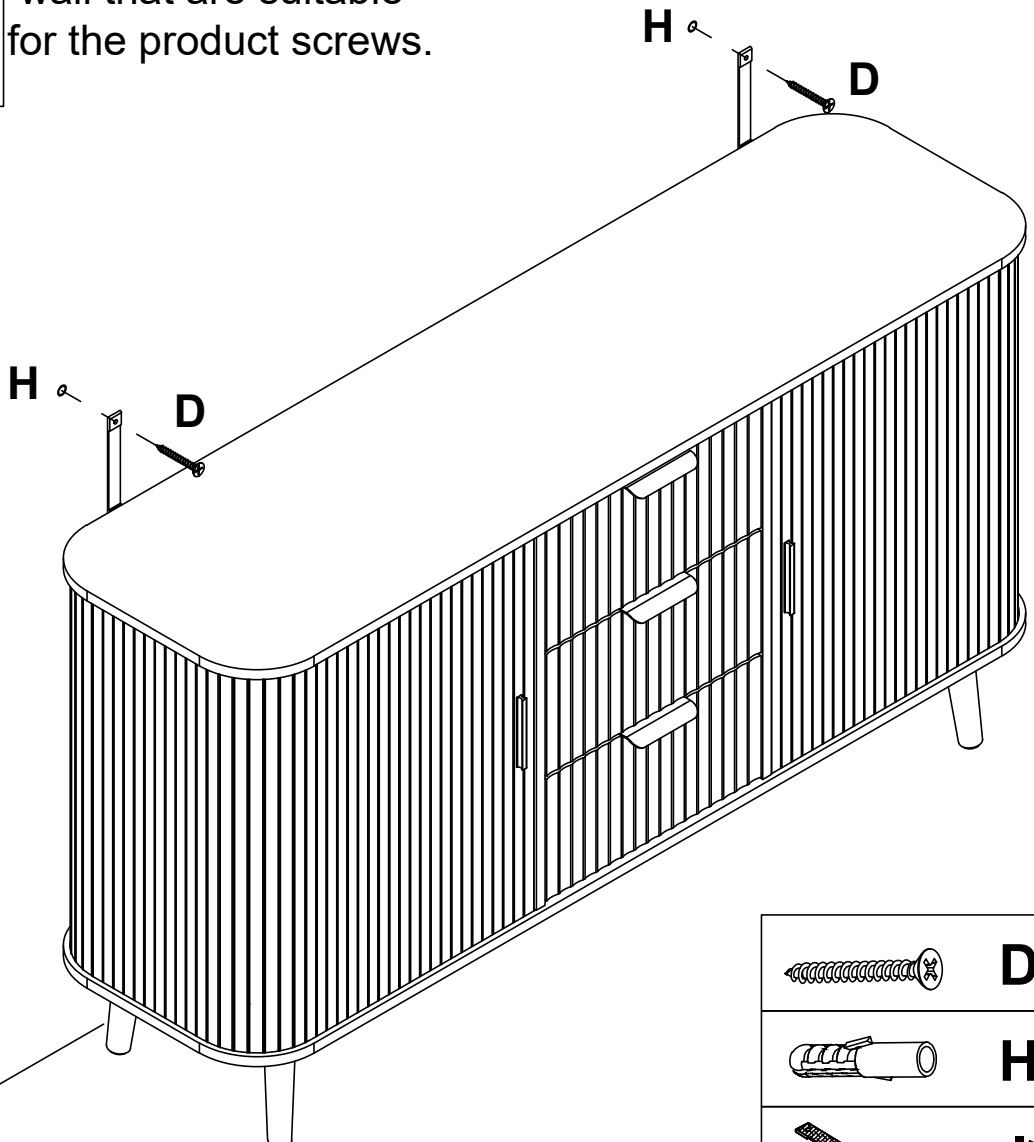
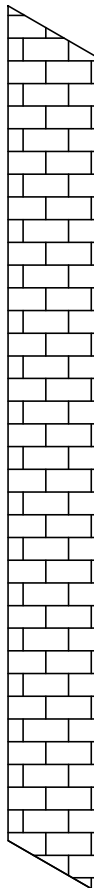

Finally, pass the matching screws through the "anti-rewind" and tighten them to fix them on the wall.

WALL



-  **D\*2**
-  **H\*2**
-  **I\*2**

# Care Instructions



Your furniture, if treated with respect and love, will last you a long time. Each piece requires light maintenance to maximize its longevity.

## Few quick tips before using this product

1. Recommended weight limit for the table top is 100lbs and 44lbs for each drawers.
2. After waxing the cabinet, you may notice some small particles falling when opening or closing the doors. This is normal and should disappear after some use.
3. When storing heavier items, place them as close to the bottom storage area as possible to maintain stability.
4. Check and tighten the camlock and screw periodically as it may loose over the time.

## How to take care of it?

1. Avoid direct sunlight or use curtains or blinds to limit the sun exposure to the product.
2. Clean the product regularly with a dry, soft cloth.
3. Avoid using abrasive or liquid cleanser.
4. Avoid placing hot objects onto the table top surface.
5. Spillage may damage the surface. Clean immediately with a dry cloth.
6. We recommend using placemats or coasters underneath glasses, cups, bowls or plates to prevent scratches to the table surface.

# Frequently Asked Questions



For any enquiries or issues regarding your purchase, chat with us at [VIPService68@outlook.com](mailto:VIPService68@outlook.com)

## 1. What should I do if my order is incomplete?

Our products ship flat-packed in separate boxes. When your order leaves via FedEx, you ' ll get an email with tracking details. Keep in mind that FedEx may deliver your boxes separately, so wait until you have them all before you start assembling. If you need help tracking your delivery, please visit [aftersaleservice.net](http://aftersaleservice.net) or email [vipservice68@outlook.com](mailto:vipservice68@outlook.com).

## 2. What should I do if my shipment is damaged or items are defective?

We ' re really sorry if you received a damaged or defective item. Please email us at [vipservice68@outlook.com](mailto:vipservice68@outlook.com) or chat with us at [aftersaleservice.net](http://aftersaleservice.net). Send a description and some photos or videos of the damage, and we ' ll sort it out as quickly as possible.

## 3. Can I order replacement parts?

Yes! Just get in touch with our customer service at [vipservice68@outlook.com](mailto:vipservice68@outlook.com) or via chat at [aftersaleservice.net](http://aftersaleservice.net). Tell us your order ID, and we ' ll help you with the parts you need.1

## 4. What warranty do you offer?

Our warranty covers damage that isn ' t caused by user error. If your product is damaged for these reasons, keep it and send us some photos at [vipservice68@outlook.com](mailto:vipservice68@outlook.com). We ' ll review the damage within 24 hours and work for you to find a solution.

## 5. Why is my cabinet door not sliding smoothly and feels a bit stuck?

Ensure that the grooves on Panel No. 1 and Panel No. 6 are properly lubricated with No. P wax during installation for smoother door movement. Additionally, after regular use, the door will become smoother over time.

## 6. Why does the new furniture have an odor?

A slight smell is normal with new furniture due to the materials and packaging. It should fade away after a few days of airing out.

## 7. Why is there a slight color difference in my furniture?

The color may appear different under varying lighting conditions and display settings. In dim lighting, the wood grain may look darker. This is completely normal and just part of the natural characteristics of the material.

## 8. My furniture seems smaller than expected. What should I do?

Our product dimensions are accurate. Pictures often focus closely on the item, which can make it appear larger than it really is. When placed in a bigger room, the furniture might seem smaller. Room layout and screen settings can also affect your perception of size. If you have any concerns or need more details, please contact our customer service at [aftersaleservice.net](http://aftersaleservice.net) or email [vipservice68@outlook.com](mailto:vipservice68@outlook.com). We're here to help!

## 9. What should I do if I want to return the product?

We offer a 30-day return policy from when you receive your order. To start a return, please contact us through Amazon, email [vipservice68@outlook.com](mailto:vipservice68@outlook.com), or visit [aftersaleservice.net](http://aftersaleservice.net). Just let us know why you ' re returning the item, and we ' ll help you out.

## **WARNING**



**Children have died from furniture tipover. To reduce the risk of furniture tipover:**

- ALWAYS install Anti-tip device provided.
- NEVER put a TV on this product.
- NEVER allow children to stand, climb or hang on drawers, doors, or shelves.
- NEVER open more than one drawer at a time.
- Place heaviest items in the lowest drawers.



*This is a permanent label.  
Do not remove!*