

DARK AND WHITE CHOCOLATE : CHOCOLAT NOIR ET BLANC : *CHOCOLATE NEGRO Y BLANCO*

DARK CHOCOLATE : CHOCOLAT NOIR : *CHOCOLATE NEGRO*

**RIGHT ASSEMBLY
INSTRUCTIONS**

**INSTRUCTIONS
D'ASSEMBLAGE DROIT**

**INSTRUCCIONES DERECHO
DE ENSAMBLAJE**

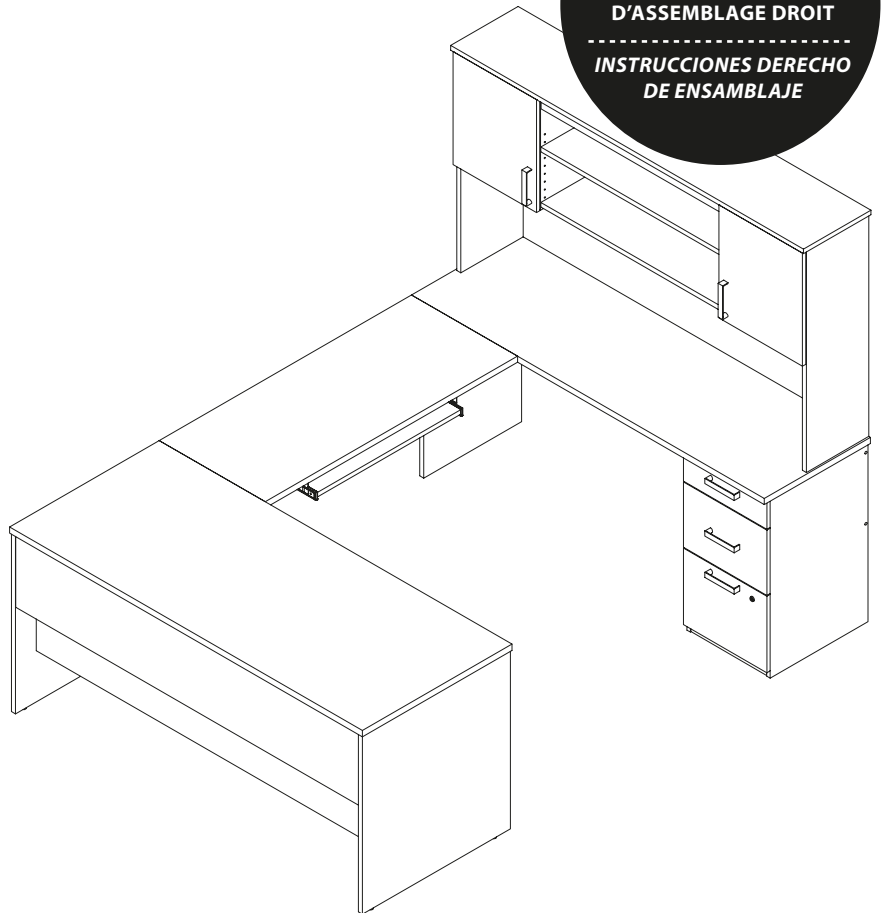

Thank you for choosing this product. Your total satisfaction is our #1 priority.

Customer service and warranty information

Should you have a problem or need more information concerning the warranty, ***do not call to the place of purchase.***
Please call our customer service department for immediate assistance using the following toll free number:

Please have your assembly instruction manual on hand when you call. Our products are warranted to the original purchaser against defects in material or workmanship in the furniture. Defects as mentioned in this warranty refer to any imperfections which may impair the use of the product. Our warranty is expressly limited to the replacement of furniture parts and components for ten years following the date of purchase. We will replace any part that is defective. This warranty applies under conditions of normal use. Our furniture products are not intended for outdoor use. The warranty does not cover defects caused by improper assembly or disassembly, defects occurring after purchase due to product modifications, intentional damage, accident, misuse, exposure to the elements and labor or assembly costs. We reserve the right to request proof of purchase to document a warranty claim. In no event shall we be liable for incidental or consequent damages resulting from the misuse of the product. This warranty is not transferable and is valid only in Canada and the United States excluding Alaska, Hawaii and Puerto Rico.

PARTS / PIÈCES / PIEZAS

CODE / CODE / CÓDIGO	QTY / QTÉ / CANT.	CODE / CODE / CÓDIGO	QTY / QTÉ / CANT.	CODE / CODE / CÓDIGO	QTY / QTÉ / CANT.	CODE / CÓDIGO	QTY / QTÉ / CANT.
CA01A	2	33	1	49	1	75	1
CA05A	2	35	1	60	1	82	1
CA09A	2	36	1	61	1	74 back panel / dos / panel trasero 161,9 cm x 38,7 cm (63 5/8 x 16 3/8 in./po.)	1
CA13A	2	40	1	62	1	CA15A bottom / fond / fondo 39,1 cm x 31,6 cm (15 3/8 x 12 1/2 in./po.)	2
17	1	41	1	66	1	TC40E	1
18	1	42	1	67	1		
20	1	43	2	70	1		
21	1	44	1	71	1		
30	1	45	1	72	1		
32	1	47	2	73	1		

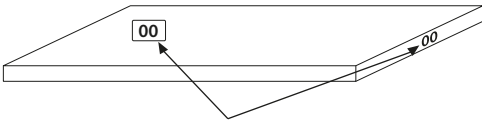

Part number on the top or on edge

Numéro de pièce sur le dessus ou sur le chant



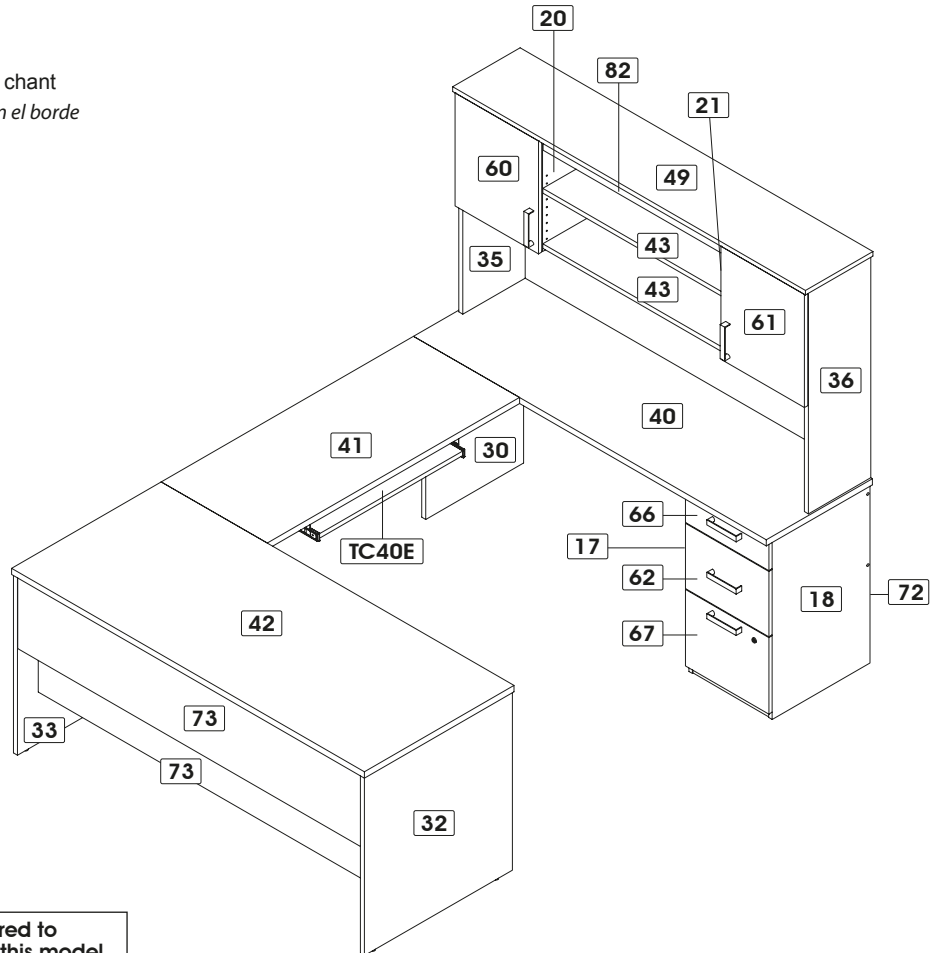















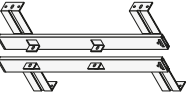

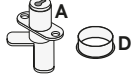

Número de referencia en la parte superior o en el borde



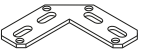

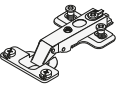
two people are required to assemble and move this model.

deux personnes sont requises pour assembler et déplacer ce modèle.
se necesitan dos personas para ensamblar y desplazar este mueble.

HARDWARE / QUINCAILLERIES / QUINCALLAS

CODE / CODE / CÓDIGO	QTY / QTÉ / CANT.	CODE / CODE / CÓDIGO	QTY / QTÉ / CANT.	CODE / CODE / CÓDIGO	QTY / QTÉ / CANT.	CODE / CODE / CÓDIGO	QTY / QTÉ / CANT.
AM-182 	4	CL-745 	1	EX-743 	2	PO-1028 	5
CA-77 	2	CO-249 	2		2	RU-420 	2
CA-99 	52	CO-834 	1	H-03 	56	SE-736 	1
CA-100 	2	EC-744 	4	H-36 	56	 not used non-utilisé no utilizado	1
CA-103 	4	EQ-143 	4	PA-844 	10	TI-452 	8
CH-838 	6	EQ-314 	3	PF-108 	1	TI-552 	1

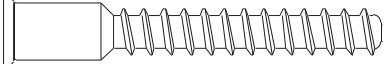
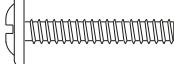
REAL SIZE / GRANDEUR RÉELLE / TAMAÑO REAL

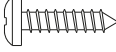
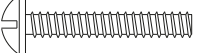
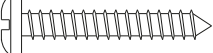
CODE / CODE / CÓDIGO	QTY / QTÉ / CANT.	CODE / CODE / CÓDIGO	QTY / QTÉ / CANT.
VC-204 	2	VM-601 	4
VE-244 	10	VR-207 	20
VF-232 	10	VR-212 	36

▶ IMPORTANT NOTICE / AVIS IMPORTANT / NOTA IMPORTANTE

Please complete self-adhesive sticker. / Assurez-vous de bien remplir l'autocollant. / Asegúrese de completar correctamente la etiqueta.

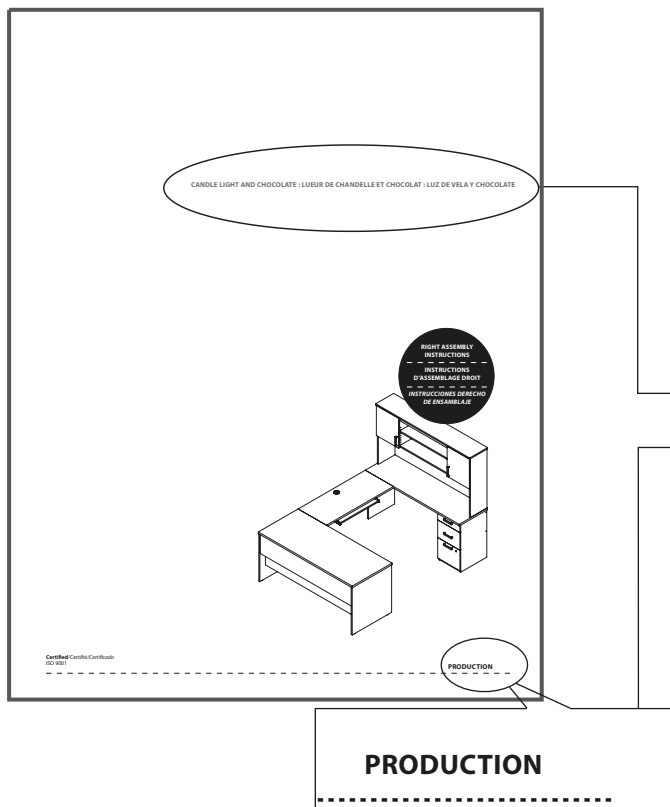

To better serve you!
Pour mieux vous servir!

Model / Modèle: _____

Production Number
Numéro de production: _____

Important/Importante

Please retain the self-adhesive sticker which you will find at a later step of the instruction manual.
Conservez l'autocollant qui sera collé seulement à une étape ultérieure du feuillet d'instructions.
Conserve la etiqueta que será pegada sólo en una etapa posterior de la hoja de instrucciones.



▶ IMPORTANT NOTICE / NOTE IMPORTANTE / NOTA IMPORTANTE

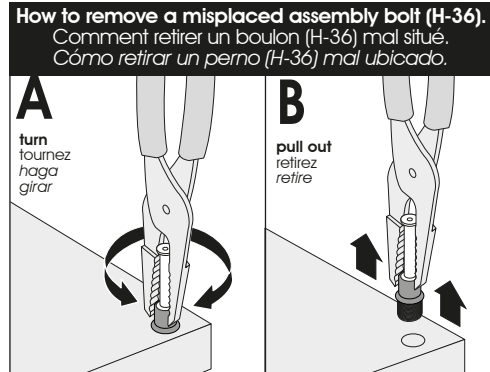
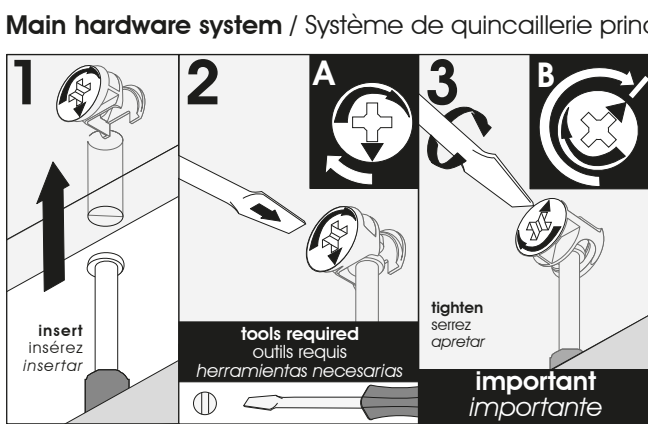
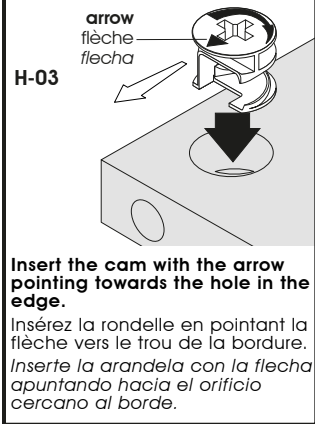

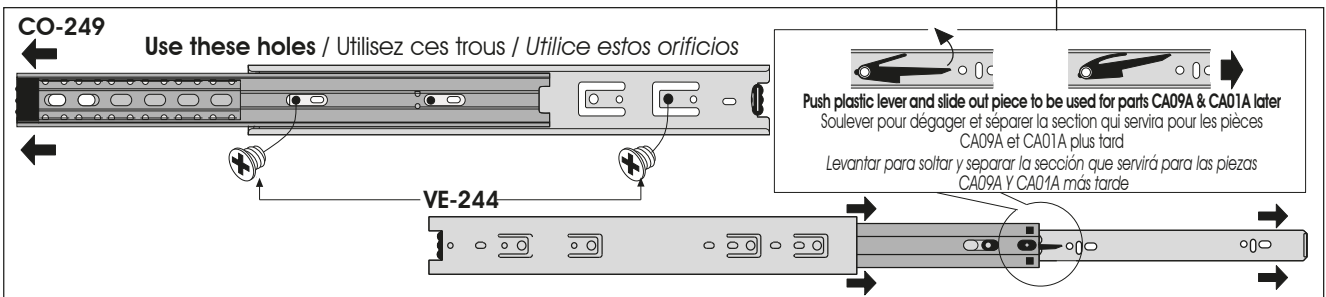
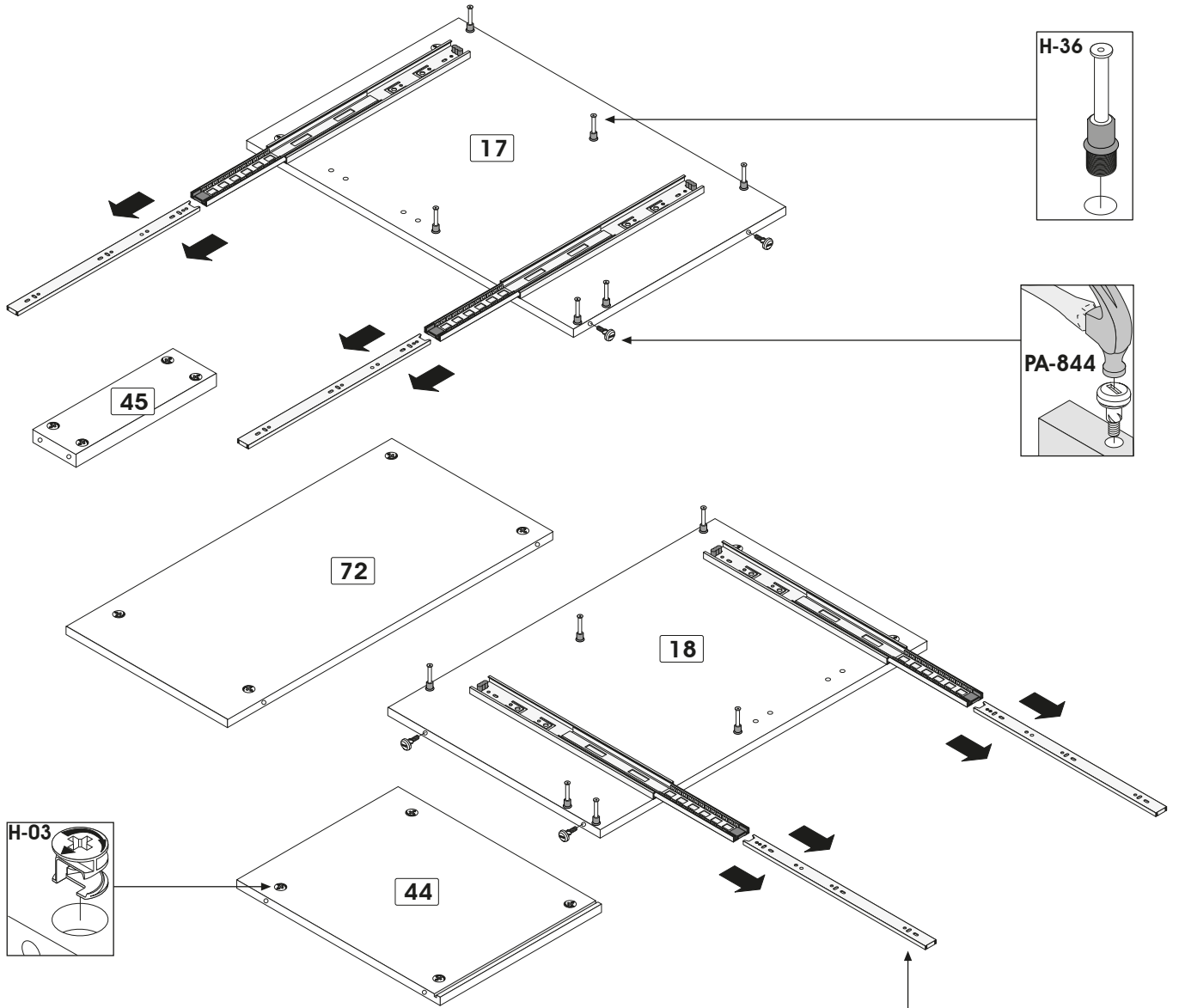

Code / Code / Código	H-03	H-36	PA-844	VE-244
Qty / Qté / Cant.	x 16	x 12	x 4	x 10
				1 cm (3/8 in./po.)

Assembling sequence

Séquence d'assemblage

Secuencia de ensamblaje

Parts / Pièces / Piezas:

18 72 45 44 17

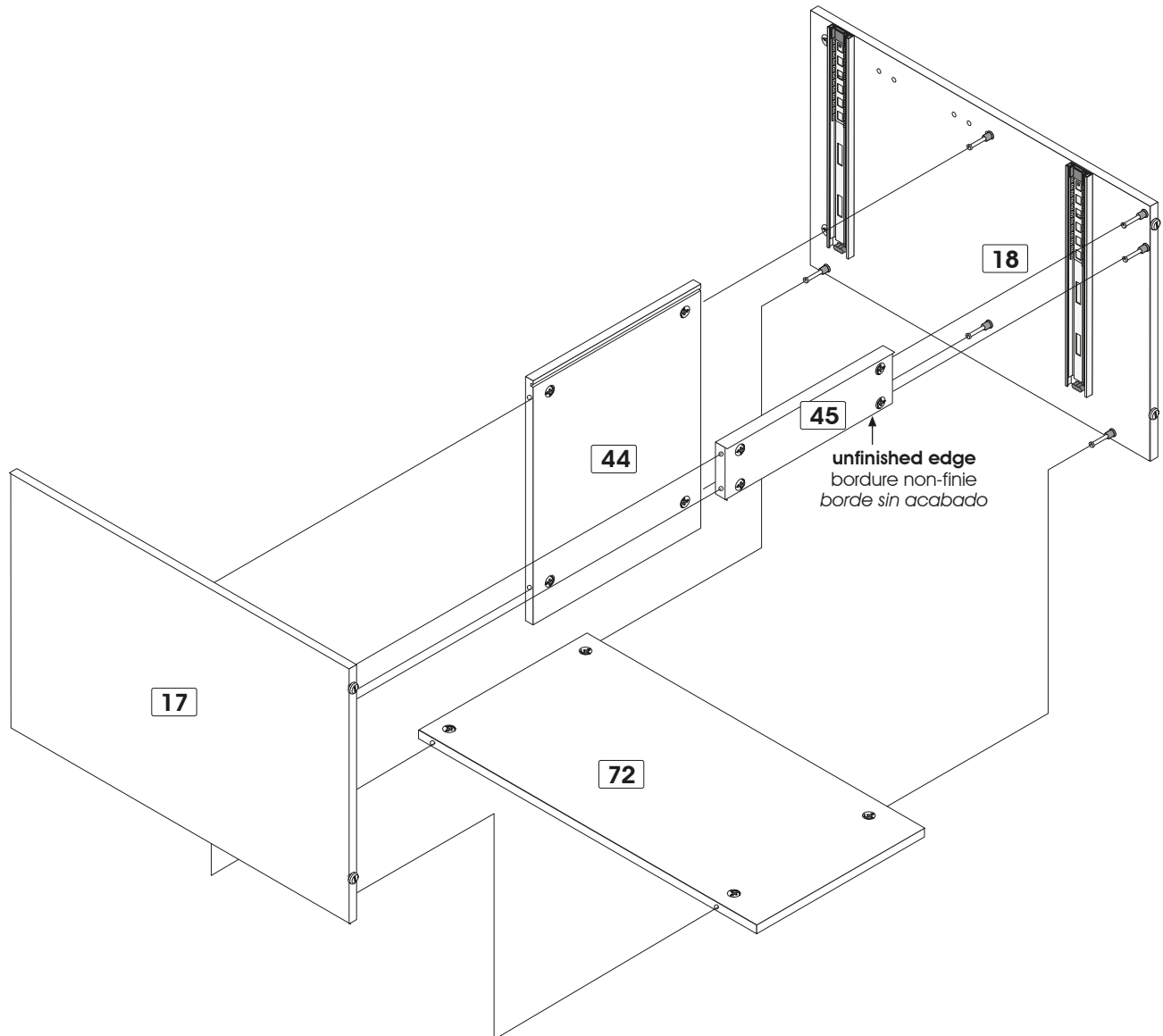

Assembling sequence
 Séquence d'assemblage
 Secuencia de ensamblaje
Parts / Pièces / Piezas:



17 18 70 + 30 40

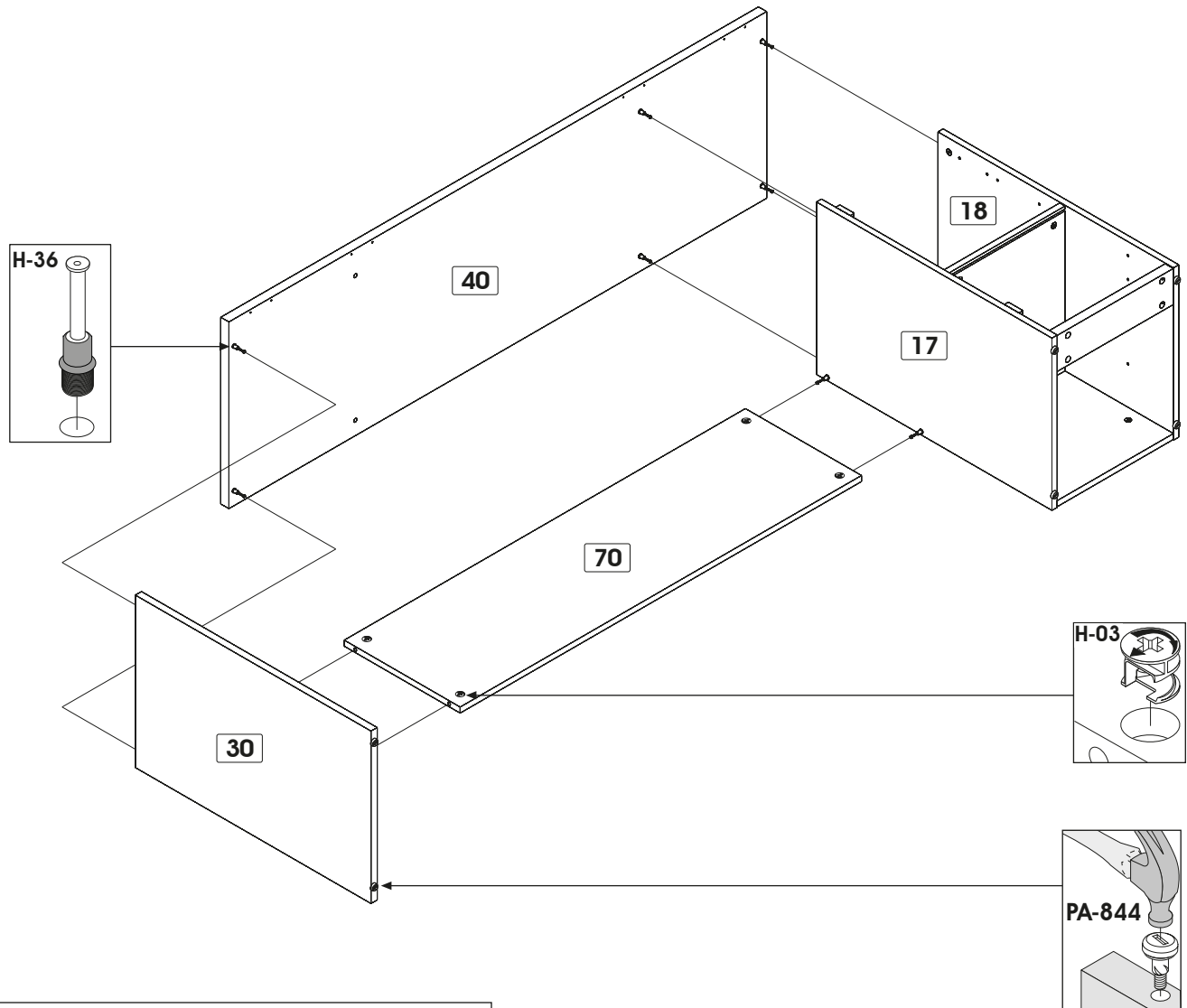

Code / Code / Código	H-03	H-36	PA-844
Qty / Qté / Cant.	x 6	x 10	x 2

Assembling sequence

Séquence d'assemblage
 Secuencia de ensamblaje

Parts / Pièces / Piezas:

42 32 73 73 33

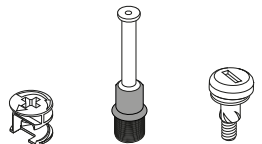
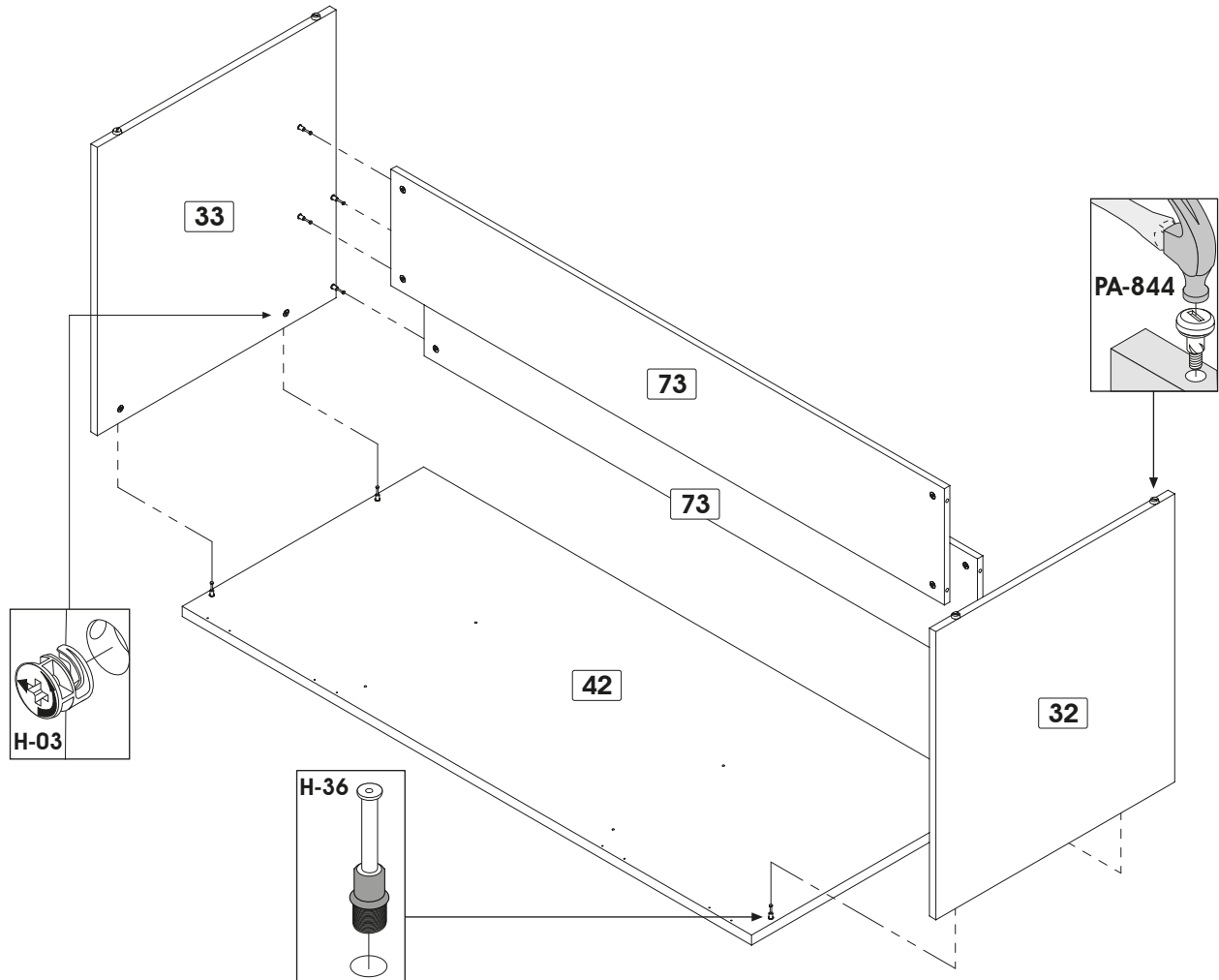

Code / Code / Código

H-03

H-36

PA-844

Qty / Qté / Cant.

x 12

x 12

x 4

Assembling sequence
 Séquence d'assemblage
 Secuencia de ensamblaje
Parts / Pièces / Piezas:



41 42

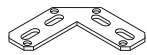
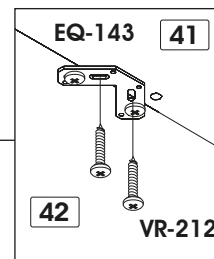
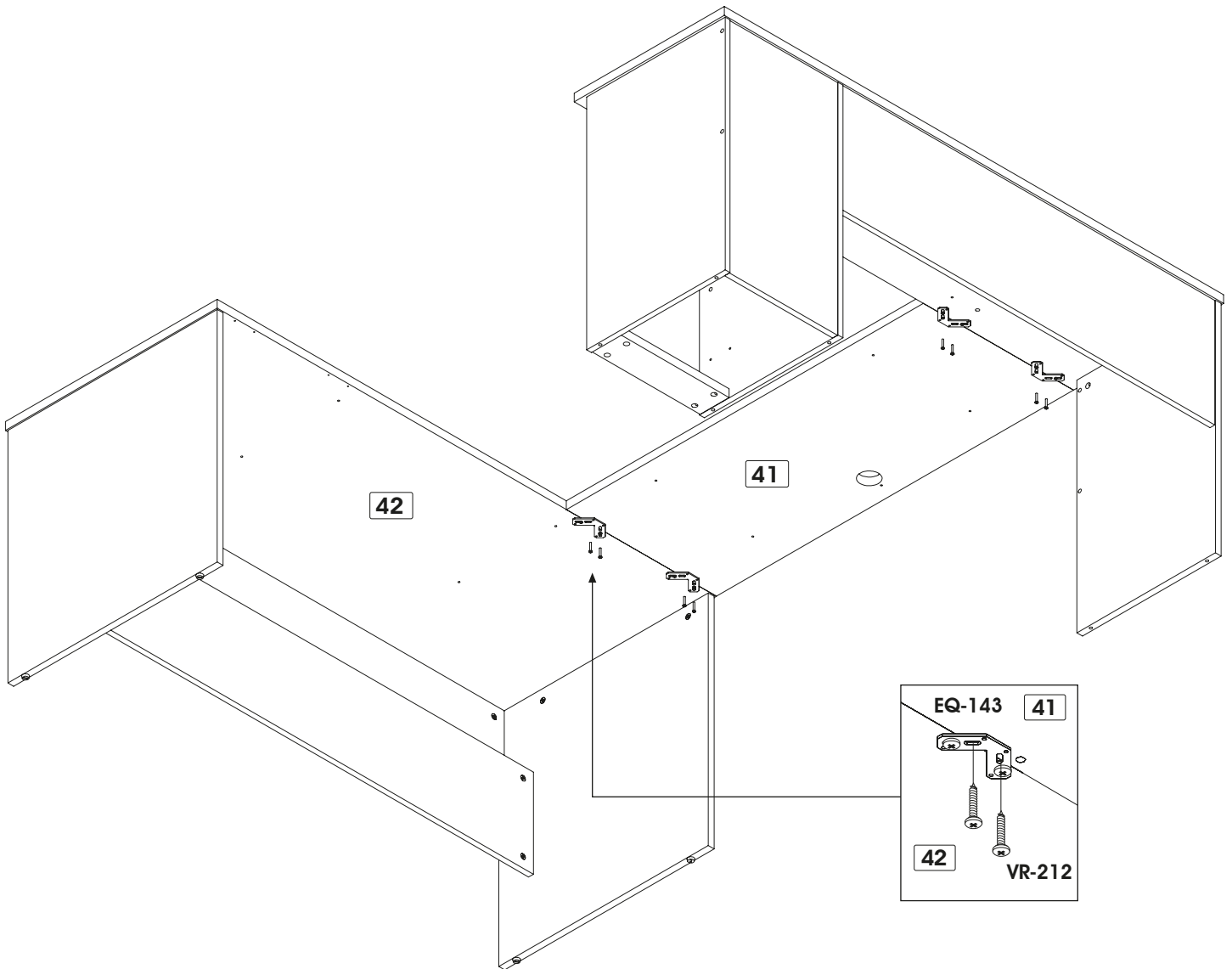

EQ-143



VR-212

2,5 cm (1 in./po.)

Code / Code / Código

Qty / Qté / Cant.

x 4

x 16

Assembling sequence

Séquence d'assemblage
Secuencia de ensamblaje

Parts / Pièces / Piezas:



U-Shaped

Configuration en U
Configuración en U

71 + 41 30 33

TI-552
Use the remaining screw
Utilisez la vis restante
Utilizar el tornillo restante

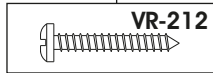
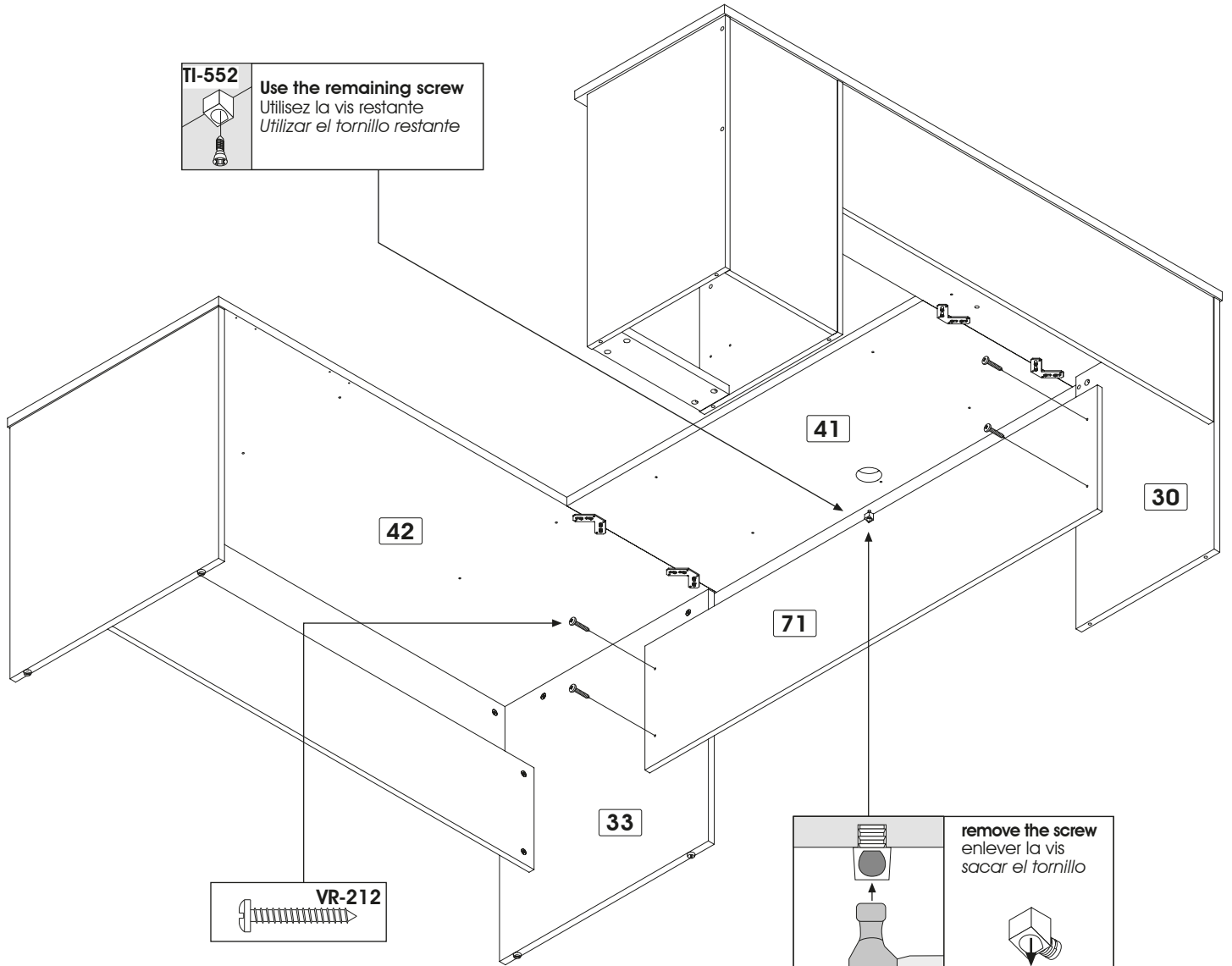

remove the screw
enlever la vis
sacar el tornillo

insert
insérer
insertar

TI-552

Code / Code / Código

TI-552

VR-212

Qty / Qté / Cant.

x 1

x 4

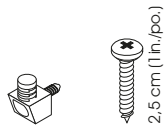

Assembling sequenceSéquence d'assemblage
Secuencia de ensamblaje

Parts / Pièces / Piezas:



75 35 36

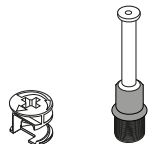
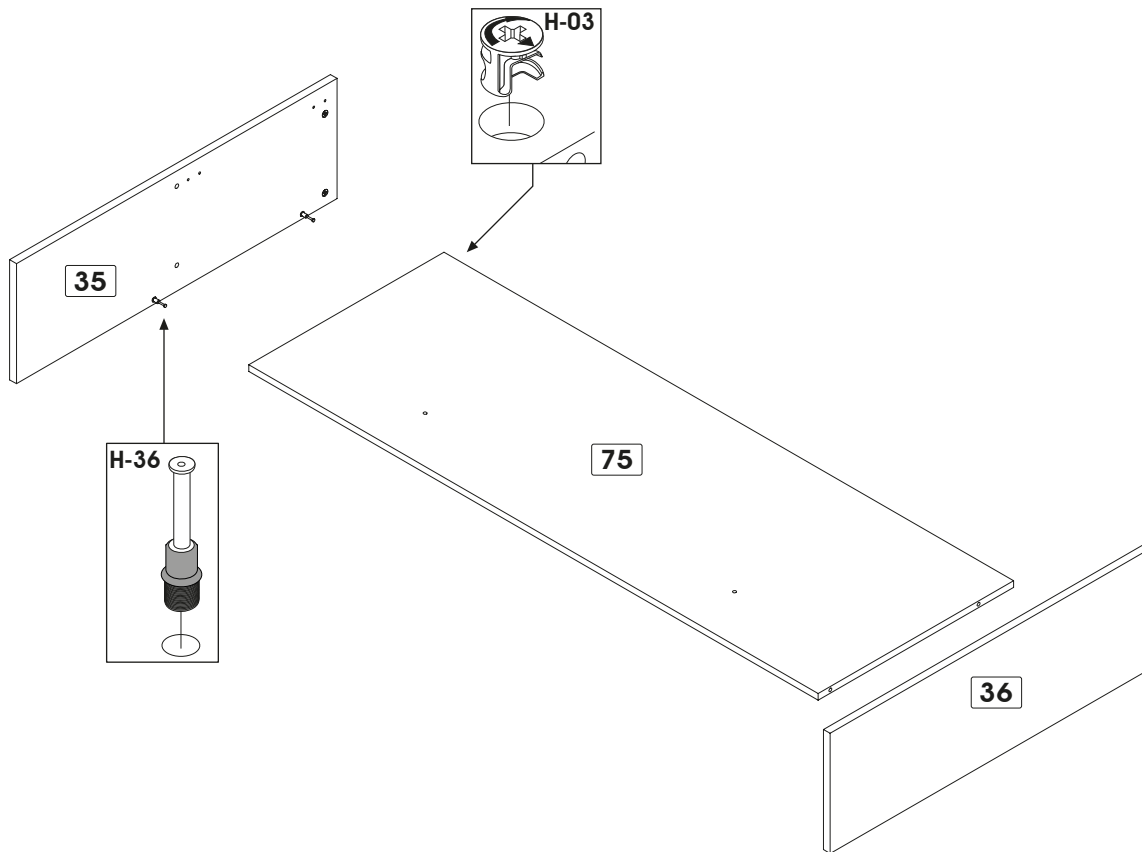

Code / Code / Código

H-03

H-36

Qty / Qté / Cant.

x 8

x 4

Assembling sequence

Séquence d'assemblage
 Secuencia de ensamblaje

Parts / Pièces / Piezas:



20 47 + 21 47 + 75 35 36

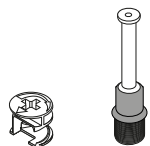
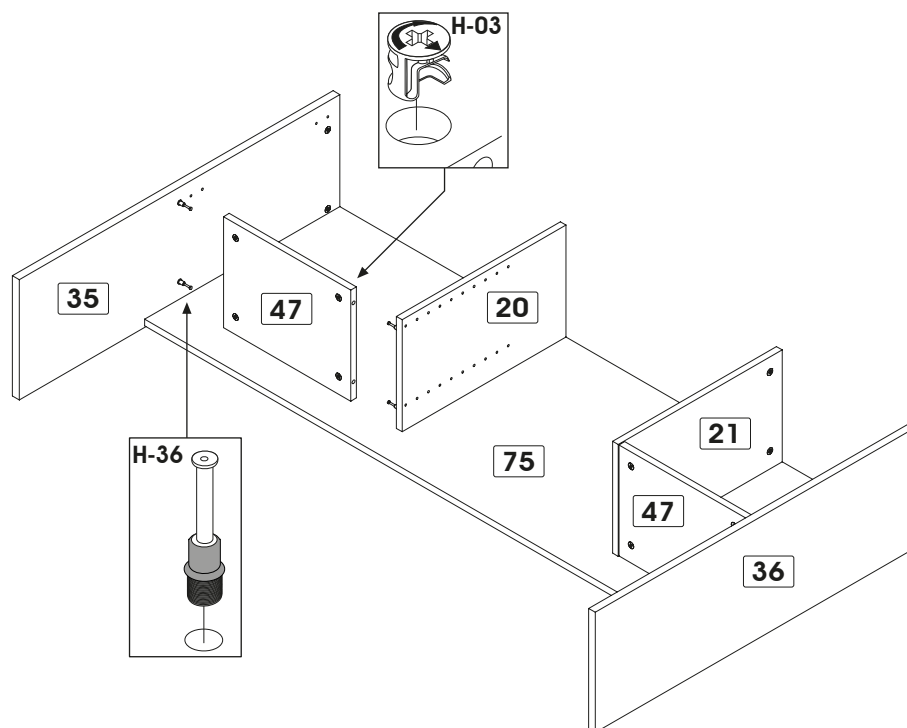

Code / Code / Código

H-03

H-36

Qty / Qté / Cant.

x 12

x 8

Assembling sequence
 Séquence d'assemblage
 Secuencia de ensamblaje
Parts / Pièces / Piezas:



49 82

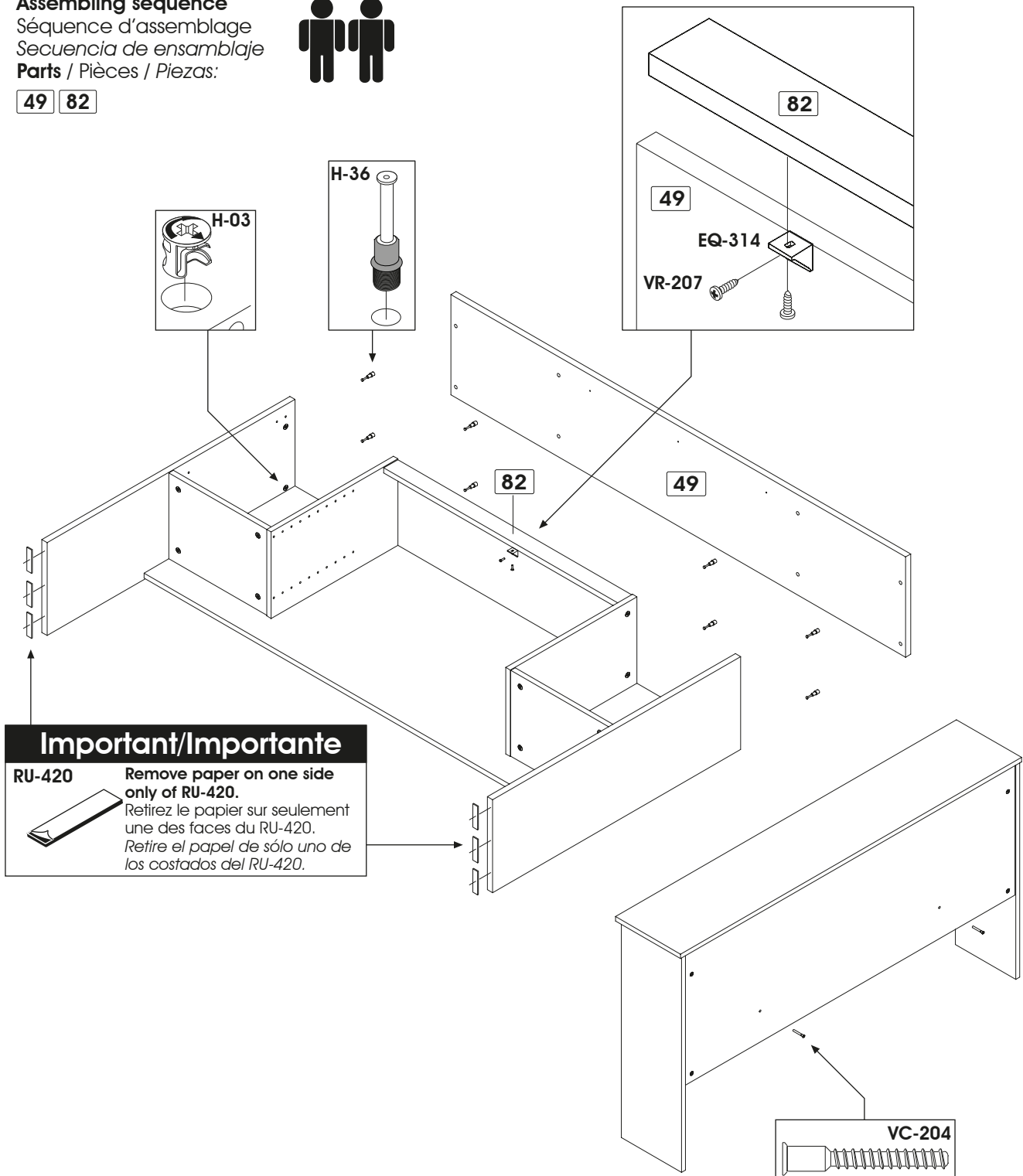

Important/Importante

RU-420 Remove paper on one side only of RU-420.
 Retirez le papier sur seulement une des faces du RU-420.
 Retire el papel de sólo uno de los costados del RU-420.

Code / Code / Código	EQ-314	H-36	RU-420	VC-204	VR-207
Qty / Qté / Cant.	x 3	x 8	x 2	x 2	x 6
				5 cm (2 in./po.)	1,3 cm (1/2 in./po.)

Assembling sequence

Séquence d'assemblage

Secuencia de ensamblaje

Parts / Pièces / Piezas:



35 **36** + **40**

Important/Importante

RU-420



Remove paper from RU-420.

Retirez le papier du RU-420.

Retire el papel del RU-420.

A **Depth alignment: Align the back of the hutch with the back of the desk.**

Alignement en profondeur : Aligner l'arrière de l'étagère avec l'arrière du bureau.

Alineamiento en profundidad : Alinear la parte posterior de la estantería con la parte posterior del escritorio.

B **Width alignment: Align side panels 35 and 36 of the hutch with the side panels of the desk.**

Alignement en largeur : Aligner les côtés 35 et 36 de la huche avec les côtés du bureau.

Alineamiento de ancho : Alinear los costados 35 y 36 de la estantería con los costados del escritorio.

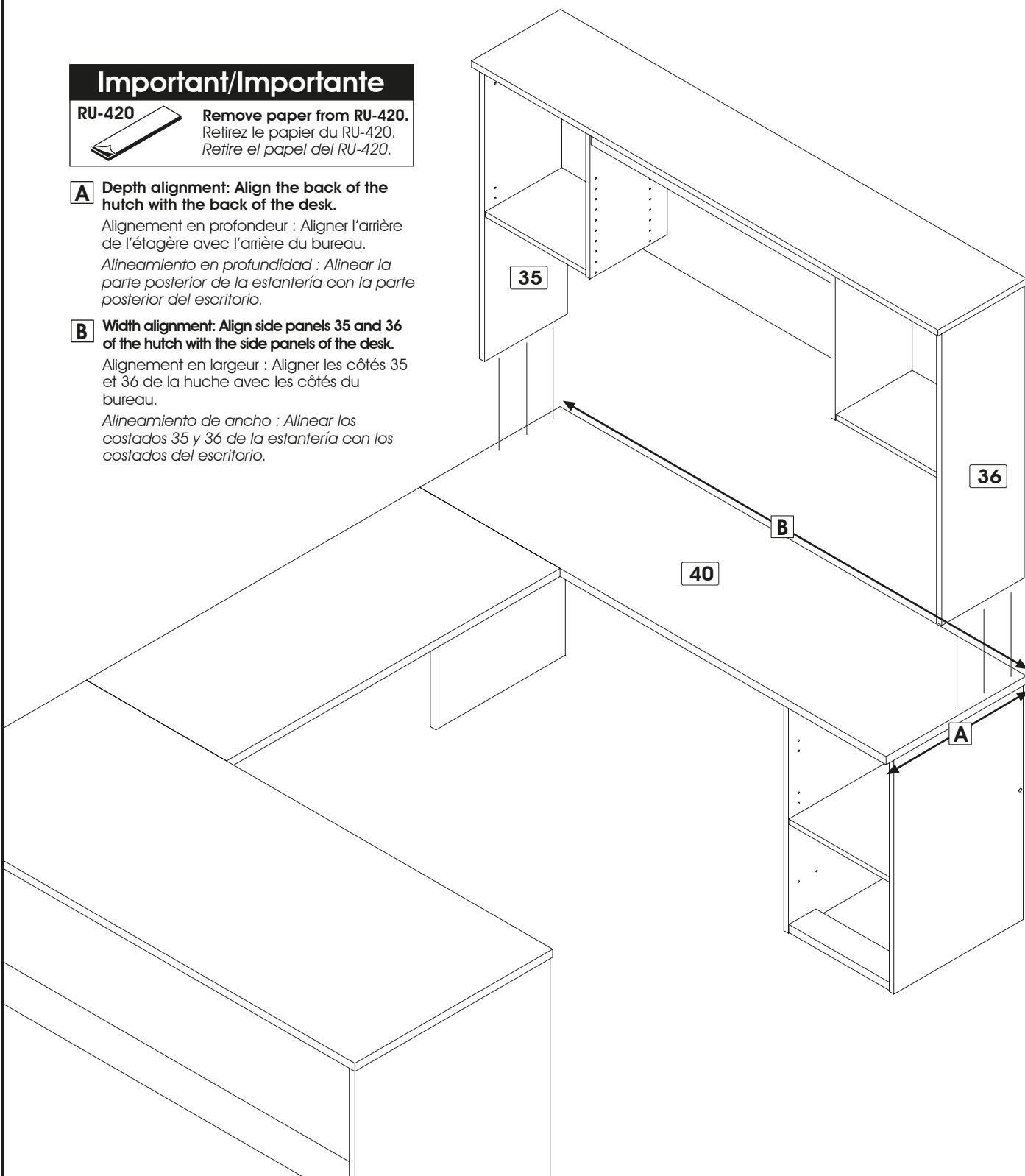

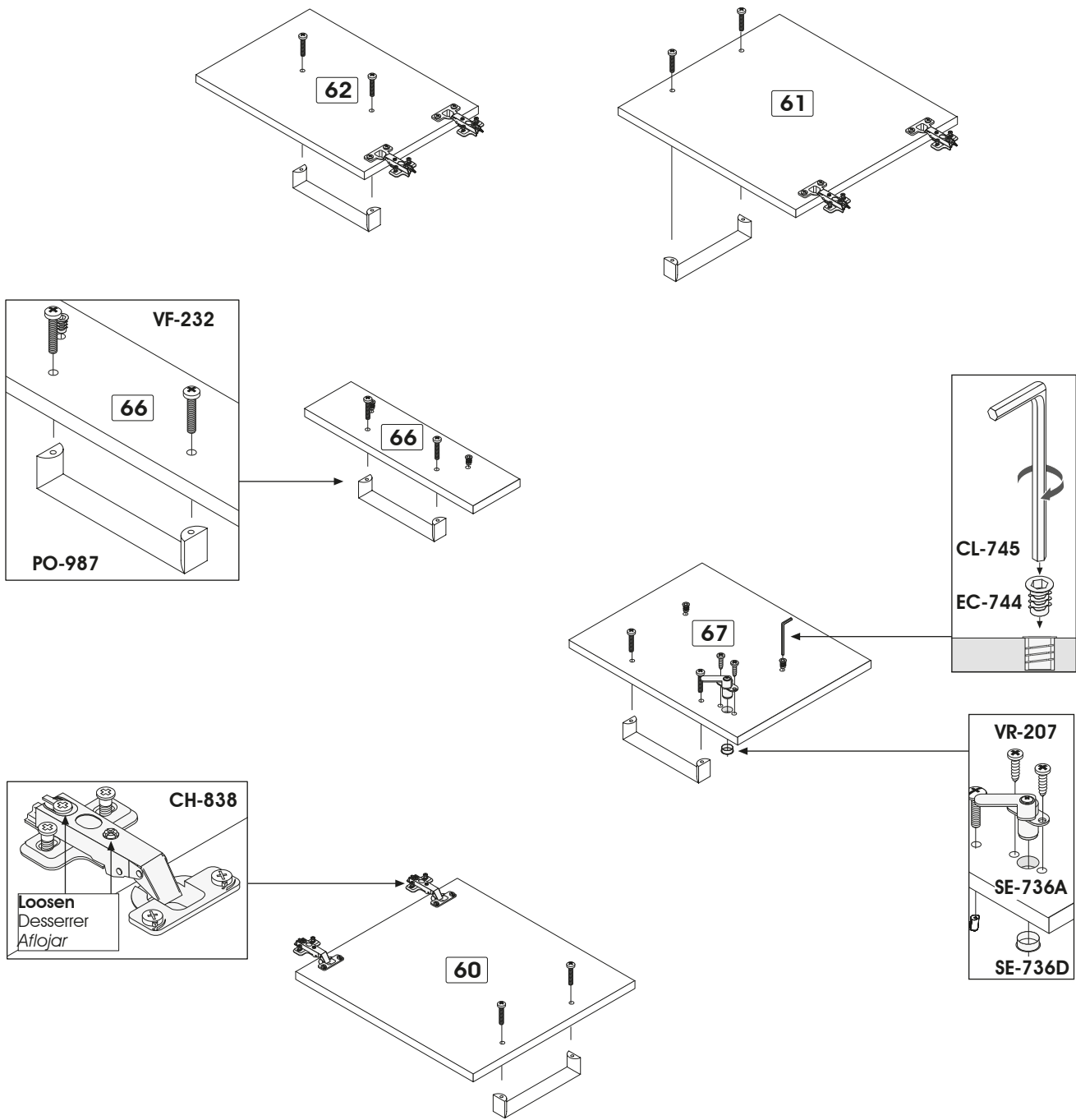

Code / Code / Código	EC-744	CL-745	CH-838	SE-736	SE-736	PO-1028	VR-207	VF-232
Qty / Qté / Cant.	x 4	x 1	x 6	x 1	x 1	x 5	x 2	x 10

not used
non- utilisé
no utilizado

1,3 cm (1/2 in./po.)

7/8" (22 mm)

Assembling sequence

Séquence d'assemblage

Secuencia de ensamblaje

Parts / Pièces / Piezas:

CA05A CA01A CA01A + CA15A + CA05A 66

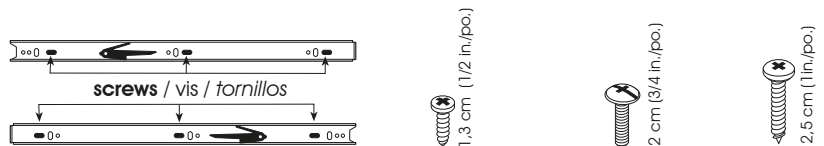
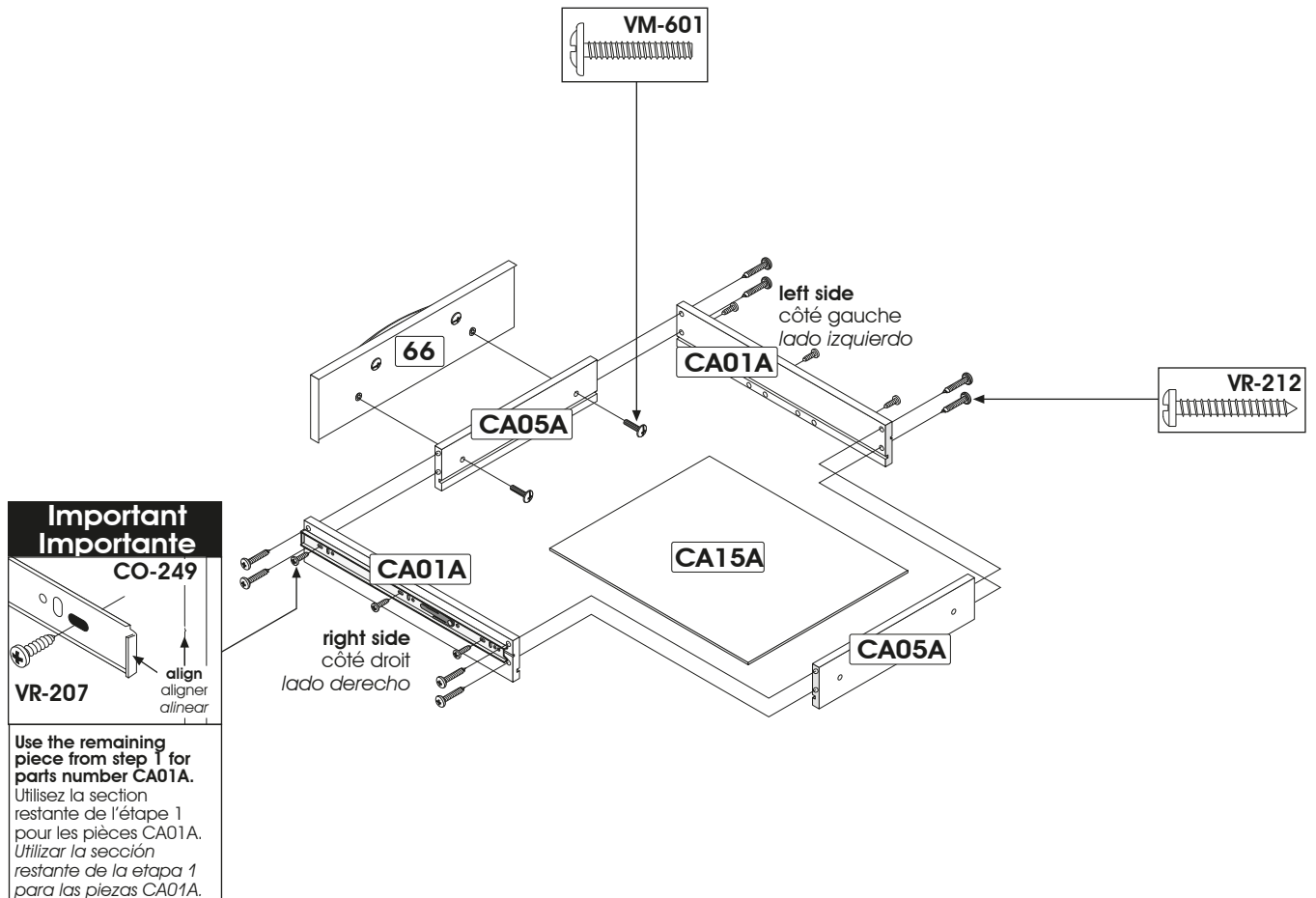

Code / Code / Código

Qty / Qté / Cant.

CO-249

x 1

VR-207

x 6

VM-601

x 2

VR-212

x 8

Assembling sequence

Séquence d'assemblage

Secuencia de ensamblaje

Parts / Pièces / Piezas:

CA13A EX-743 + CA09A EX-743 + CA09A EX-743 +
CA15A + CA13A EX-743 + 67

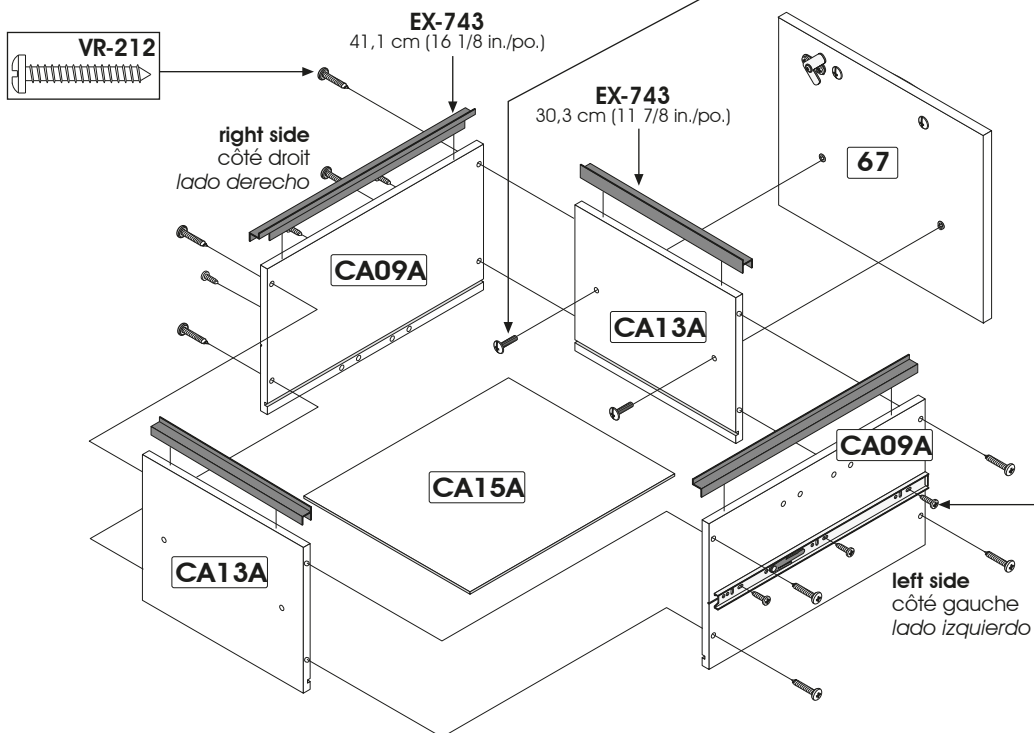
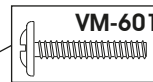

Important / Importante

align / aligner / alinear

Use the remaining piece from step 1 for parts number CA09A.
Utilisez la section restante de l'étape 1 pour les pièces CA09A.
Utilizar la sección restante de la etapa 1 para las piezas CA09A.

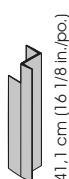
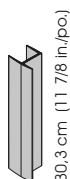
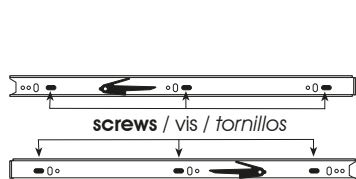
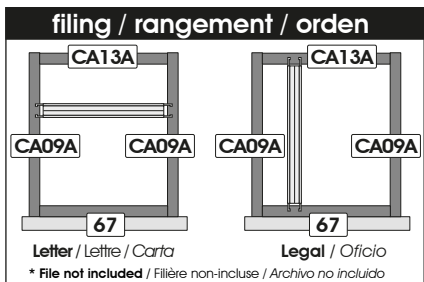

Code / Code / Código	CO-249	EX-743	EX-743	VR-207	VM-601	VR-212
Qty / Qté / Cant.	x 1	x 2	x 2	x 6	x 2	x 8

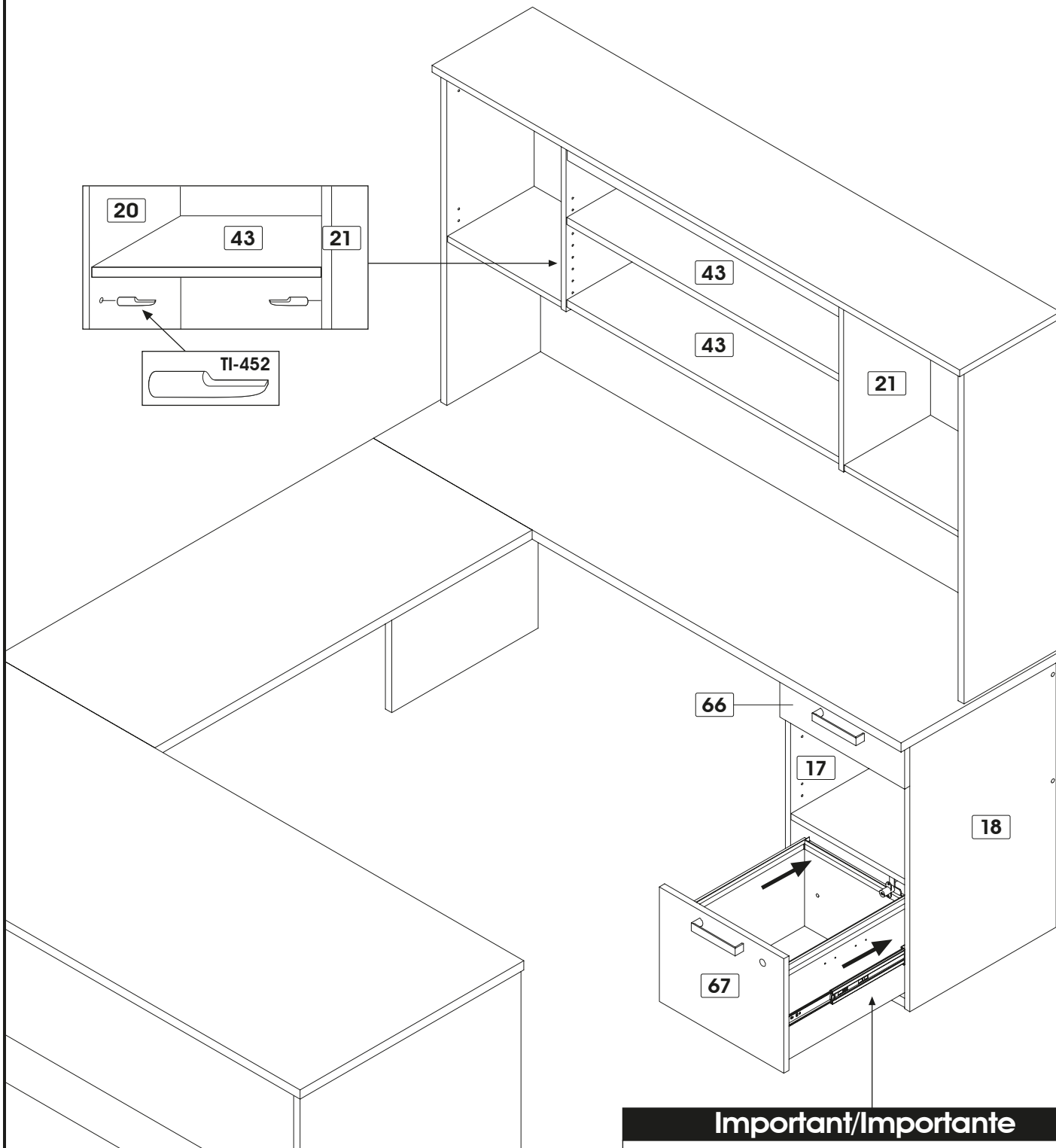

14



Code / Code / Código TI-452
Qty / Qté / Cant. x 8

Important/Importante

Ball bearings must be on front part of slider when installing drawers.
 Les roulements à billes doivent être sur la partie avant du coulisseau lors de l'installation des tiroirs.
 Los cojinetes de bolas deben ubicarse sobre la parte delantera de la corredera guía en el momento de instalar los cajones.

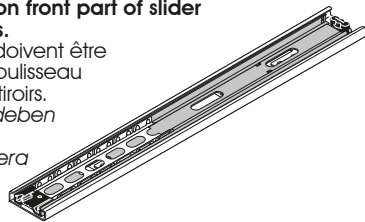

15 INSTALLATION / INSTALLATION / INSTALACIÓN

DOORS / PORTES / PUERTAS

Use screw **A** for horizontal adjustment, screw **B** for depth adjustment and screws **C** for vertical adjustment.

Utilisez la vis **A** pour l'ajustement horizontal, les vis **B** pour l'ajustement en profondeur et les vis **C** pour l'ajustement vertical.

Utilice el tornillo **A** para realizar el ajuste horizontal, los tornillos **B** para el ajuste de profundidad y los tornillos **C** para el ajuste vertical.

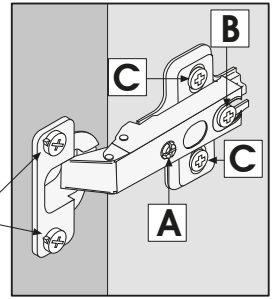

To remove hinges, start by loosening these two screws to free the locking system.

Pour enlever les pentures, desserrez ces deux vis d'abord pour libérer le système de verrouillage.

Para retirar las bisagras, afloje primero estos dos tornillos para liberar el sistema de fijación.

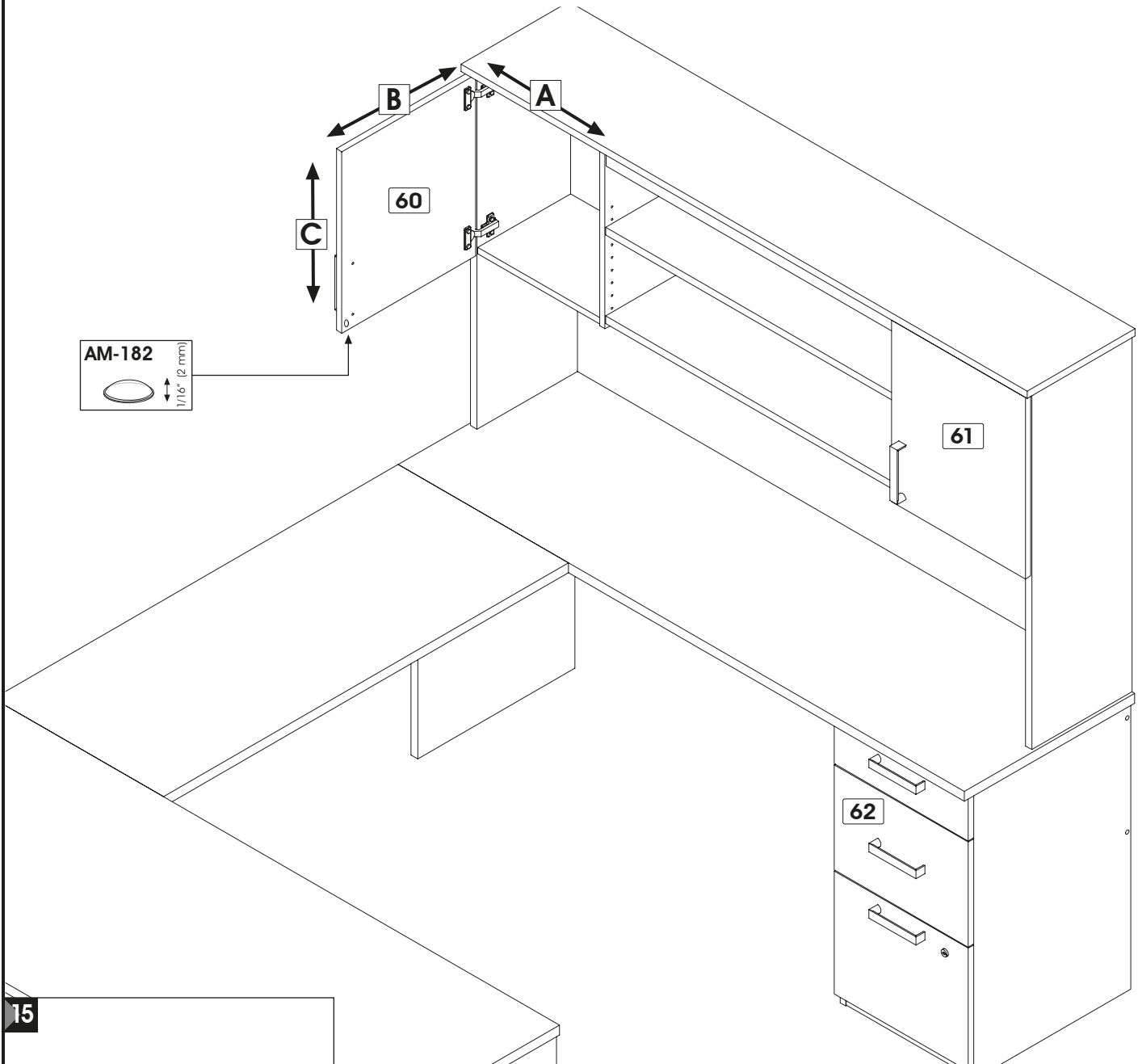

15	
Code / Code / Código	AM-182
Qty / Qté / Cant.	x 4

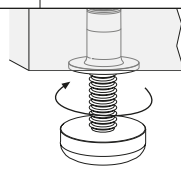

To level your furniture, use leg levelers.

Pour niveler votre meuble utilisez les pattes ajustables.

Para nivelar su mueble utilice las patas ajustables.

important / importante

Drive the screw all the way in to install CO-843.
 Vissez à fond avant d'installer la CO-843.
 Atornille a fondo antes de instalar el CO-843.

CO-843
TC40E

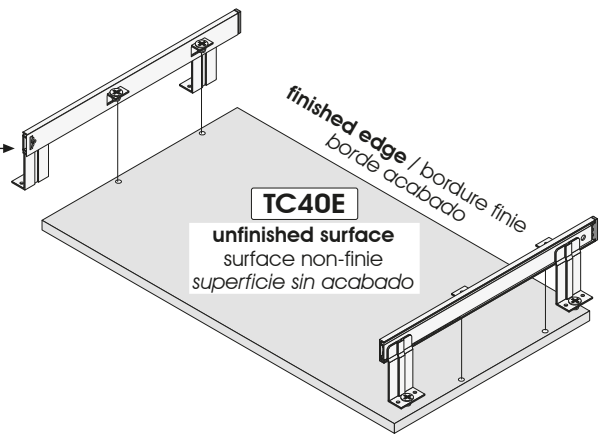

16

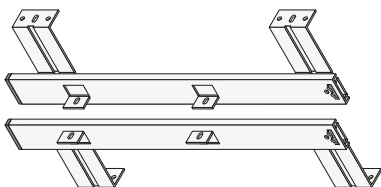

Code / Código

CO-843

Qty / Qté / Cant.

x 1

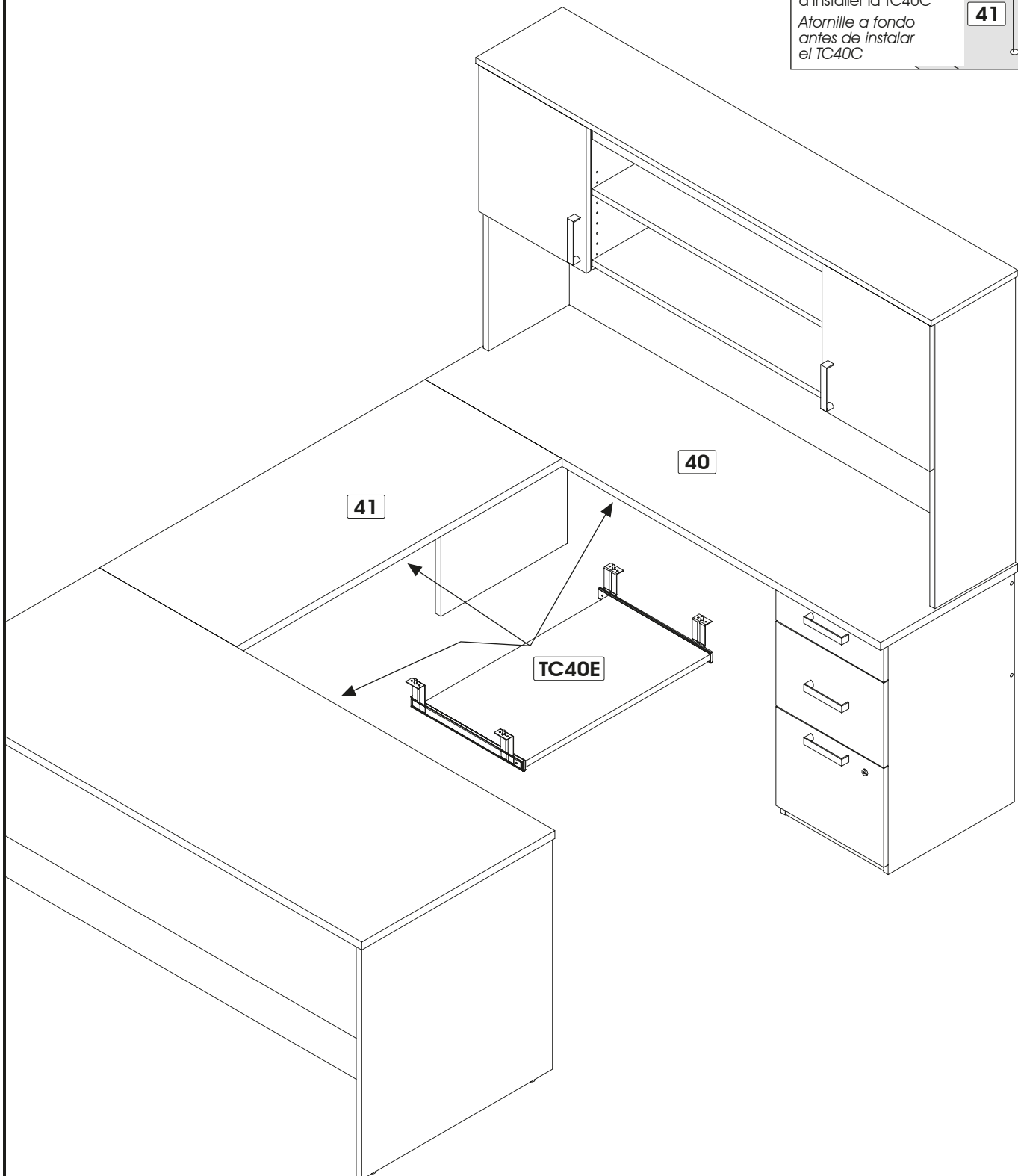
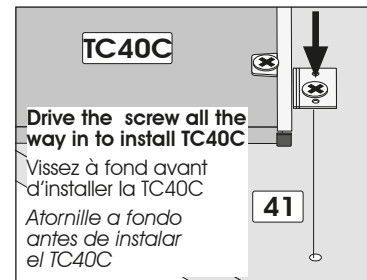
important / importante**3 possibilities / 3 possibilités / 3 posibilidades**

Important / Importante

To better serve you!
Pour mieux vous servir!

Model / Modèle: _____

Production Number
Numéro de production: _____

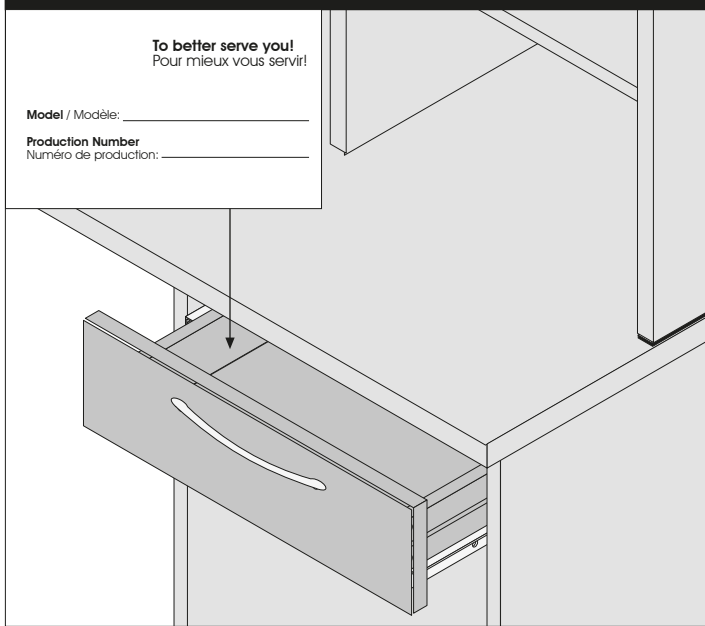

For future reference and to better serve you, please apply the self-adhesive sticker in an accessible space such as inside a drawer.

Pour mieux vous servir en cas de besoin, veuillez apposer l'autocollant dans un endroit facilement accessible tel que l'intérieur d'un tiroir.

Para futura referencia y mejor servicio por favor pegue la etiqueta en un lugar accesible, por ejemplo al interior de un cajón.

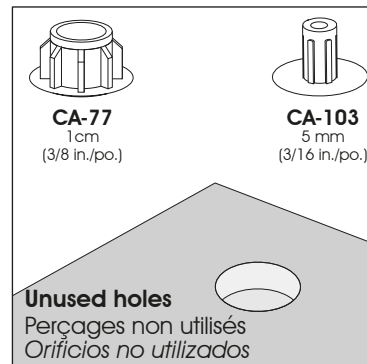
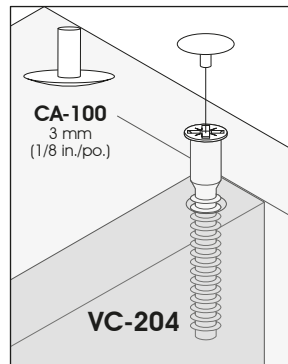
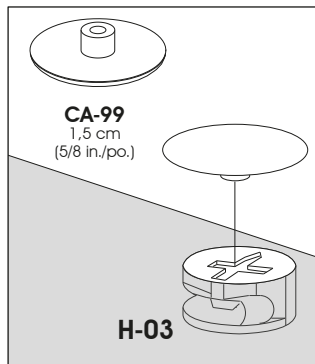

When you have completed the assembly of your new furniture, install plastic caps.
Lorsque vous avez complété l'assemblage de votre meuble, installez les capuchons de plastique.
Una vez que haya ensamblado el mueble, coloque los capuchones de plástico.

PRODUCT CARE / ENTRETIEN DU PRODUIT / MANTENIMIENTO DEL PRODUCTO

Avoid placing the furniture in sunlight or near a source of heat. Use a soft dry cloth for dusting. To clean heavy dirt, use a cloth dipped in a solution of mild detergent and water. Avoid leaving wet objects on the surface or using commercial chemical cleaning products.

Évitez d'exposer le meuble au soleil ou près de toute source de chaleur. Pour le nettoyage, utilisez un chiffon doux et sec. Pour la grosse saleté, utilisez un chiffon humidifié avec un peu de détergent dilué dans l'eau. Évitez de laisser des objets mouillés sur la surface de votre meuble ou d'utiliser des nettoyeurs chimiques.

Evite exponer el mueble al sol o las fuentes de calor. Para limpiarlo, utilice un paño suave y seco. Para limpiar las manchas rebeldes, utilice un trapo húmedo con un poco de detergente diluido en agua. No deje objetos mojados encima del mueble ni utilice limpiadores que contengan productos químicos.

CONGRATULATIONS! YOU ARE NOW THE OWNER OF A QUALITY PRODUCT
FÉLICITATIONS! VOUS AVEZ MAINTENANT EN VOTRE POSSESSION UN PRODUIT DE QUALITÉ
FELICITACIONES! AHORA ES USTED DUEÑO DE UN PRODUCTO DE CALIDAD.



For more information or to discover our new products

Pour toute information ou pour découvrir nos nouveaux produits

Para obtener más información o para obtener nuevos productos



FOR LONG TIME
POUR LONGTEMPS
POR MUCHO TIEMPO



OUR FURNITURE IS GARANTEED FOR 10 YEARS. NO MATTER THE PROBLEM, OUR CUSTOMER SERVICE IS THERE FOR YOU.

NOS MEUBLES SONT GARANTIS POUR 10 ANS. PEU IMPORTE LE PROBLÈME, N'HÉSITÉZ PAS À COMMUNIQUER AVEC NOTRE SERVICE À LA CLIENTÈLE.

NUESTROS MUEBLES TIENEN UNA GARANTIA DE 10 AÑOS. NO IMPORTA EL PROBLEMA, COMUNIQUE CON NUESTRO SERVICIO A CLIENTE.