

# **Assembly Instructions**

**Focus on Furniture, Cherish for People**

## CUSTOMER CARE

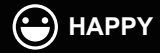

**Congratulations  
Happy shopping  
Feel free to share with your friends or family  
Thank you for your 5-star feedback and positive  
reviews to help others  
Good advice leads to the best service**



**We apologize for the bad shopping experience  
Any defects, broken, missing pieces, delays or  
accidents Please contact us as soon as possible**

## CONTENT:

- › Profile
- › Part list
- › Hardware List
- › Assembly Instruction
- › Product Parameters
- › User Manual
- › Fault Detection and Handling

## NOTICE:

- › Basic precautions should always be followed when using this product. Please read all instructions before using the cabinet and retain the education for future reference.
- › Failure to observe all instructions and warnings may cause severe property damage or personal injuries.
- › Check the product and hardware accessories in the box; and confirm whether the instructions are complete.
- › When installing, please pay attention to the protection of the parts. The soft material must be placed under the product, and please carefully handle it to avoid surface damage.
- › After the assembly is completed, please adjust the placement position according to the actual situation.
- › Keep children away from cabinets, accessories, and installation tools. They are at risk of injury to the child.
- › Two people are recommended for assembly.
- › The wall plugs supplied are for use on solid walls only. For cavity walls or plasterboard use specialist fixings that are suitable for the type of wall construction.
- › To retain the best quality finish, clean product regularly with a soft damp cloth.
- › The max load of the cabinet is 10kg when fitted to a solid wall and 5kg when fitted to a cavity wall.
- › Risk of electric shock. Connect this furnishing to a properly grounded circuit only. See Grounding instructions  
If you need the electronic manual, please contact our customer service to get it.



For reference only



Parts may vary.  
(Optional)



Warning! Please take  
special care.

## RETURN/DAMAGE CLAIM INSTRUCTIONS:

- › The product is shipped in a single carton box. If you haven't received the package or need to know the tracking of the package, get in touch with us immediately.
- › If the package is damaged, please get in touch with us from the very beginning. Attaching a damaged photo is appreciated.
- › The product accepts returns within 30 days without any reason. If you return this item for personal reasons, you must cover the return fee and order processing fee (0- 20% restocking fee based on the invoice price). We will cover the freight if the product has quality issues (not caused by humans).
- › Please keep the original box if you need to return the goods. Please use our return label and do not return it without permission.
- › If you return the product after 30 days of receiving it, we are afraid your return application won't be accepted. We appreciate your understanding.
- › Any damages, defects and parts missings during installation, please contact us from the very beginning. Replacement, exchange and refund will be arranged ASAP except of personal reasons.

## Part List



Open the package, and put the item on the mat with care.  
Please install it carefully to ensure your fingers will not be scratched.

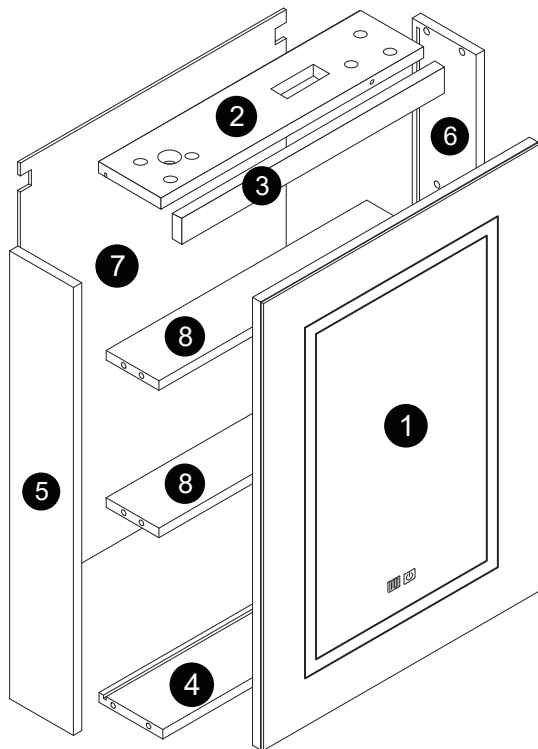
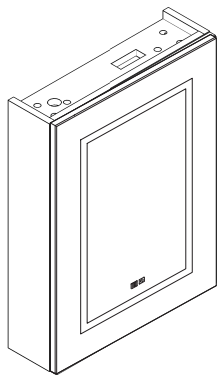

## Hardware List

**A**



M6\*40mm  
×18 (+2)

**B**



φ15\*12mm  
×18 (+2)

**D**

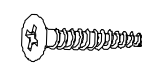

M4\*30mm  
×4

**C**



M3.5\*14mm  
×20 (+2)

**E2**

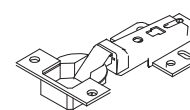

×3

**T**



×18 (+2)

**Q**

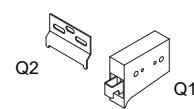

×2

**F**



M5\*80mm  
×4

**M**



×1

**P**



×8 (+2)

**R**

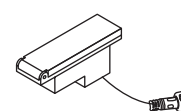

×1

**N**

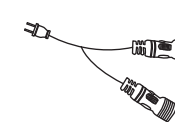

×1

Start...

| Step1

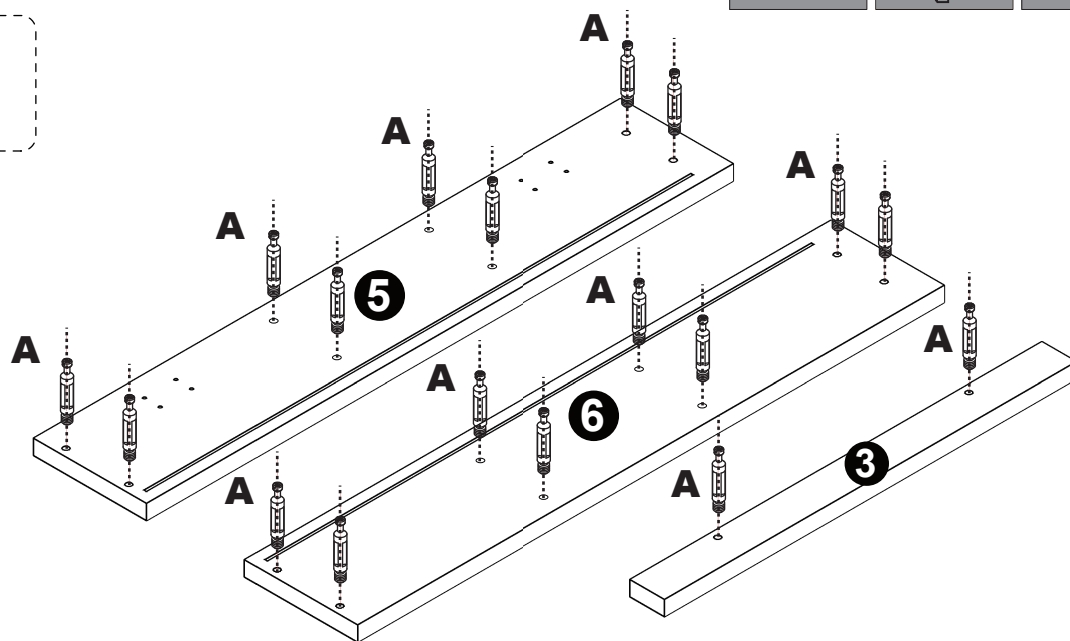
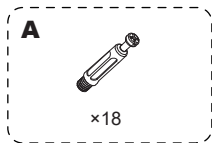

Installation method of three in one rod and buckle

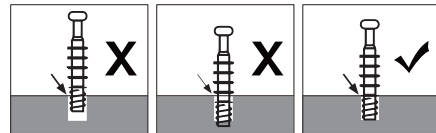

| Step2

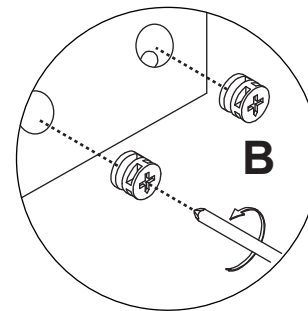
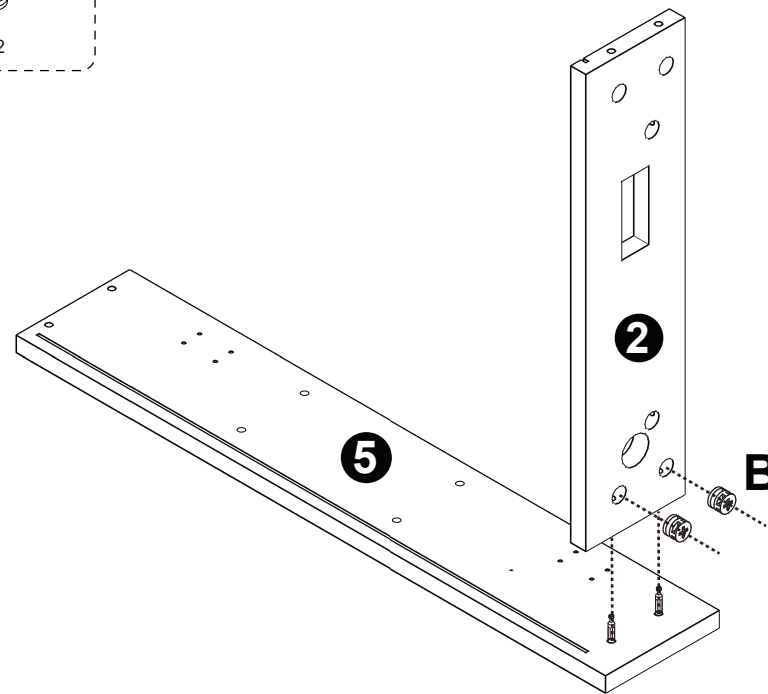

| Step3

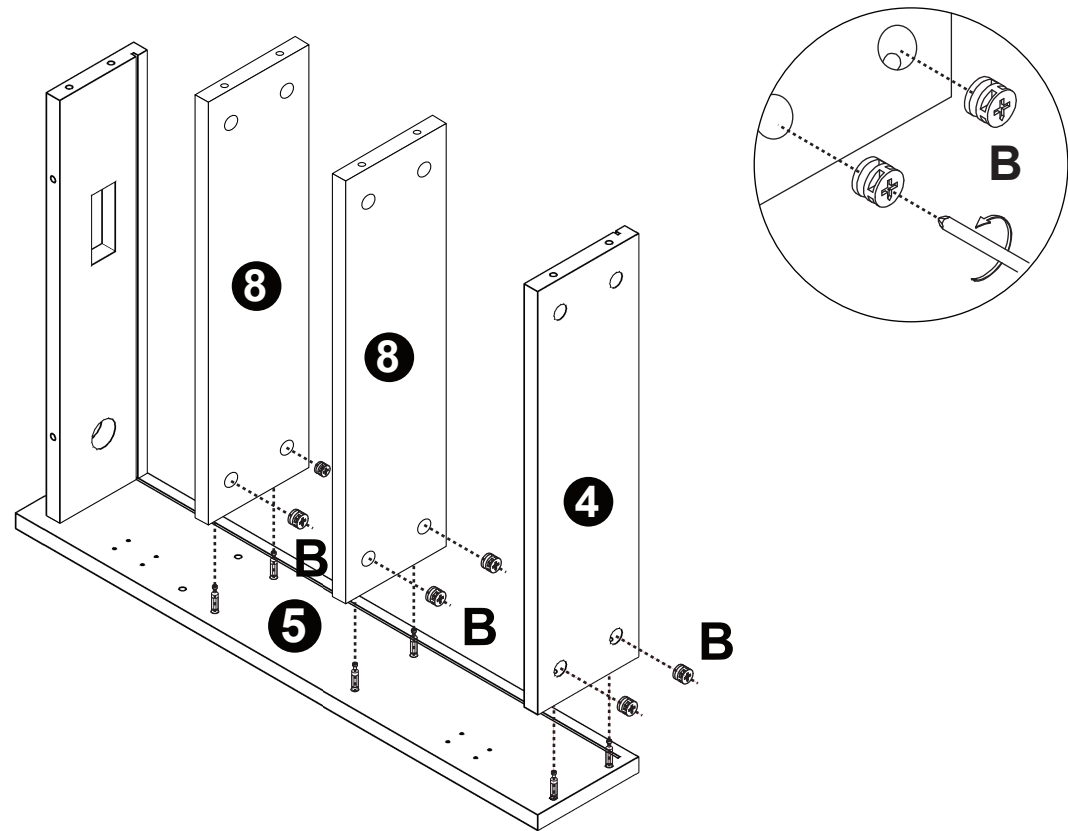
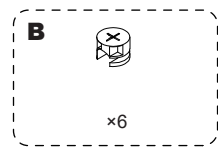

| Step4

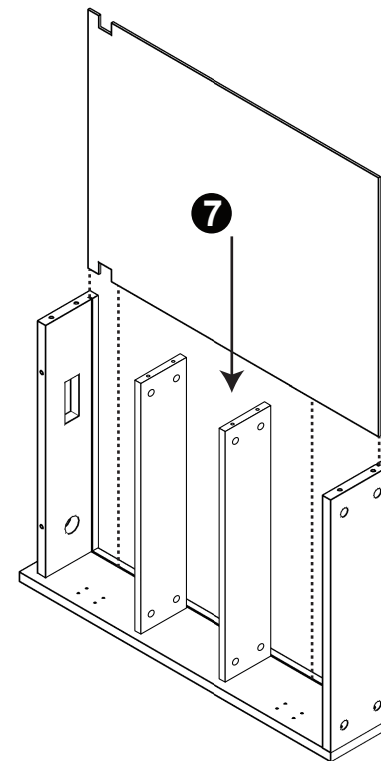

| Step5

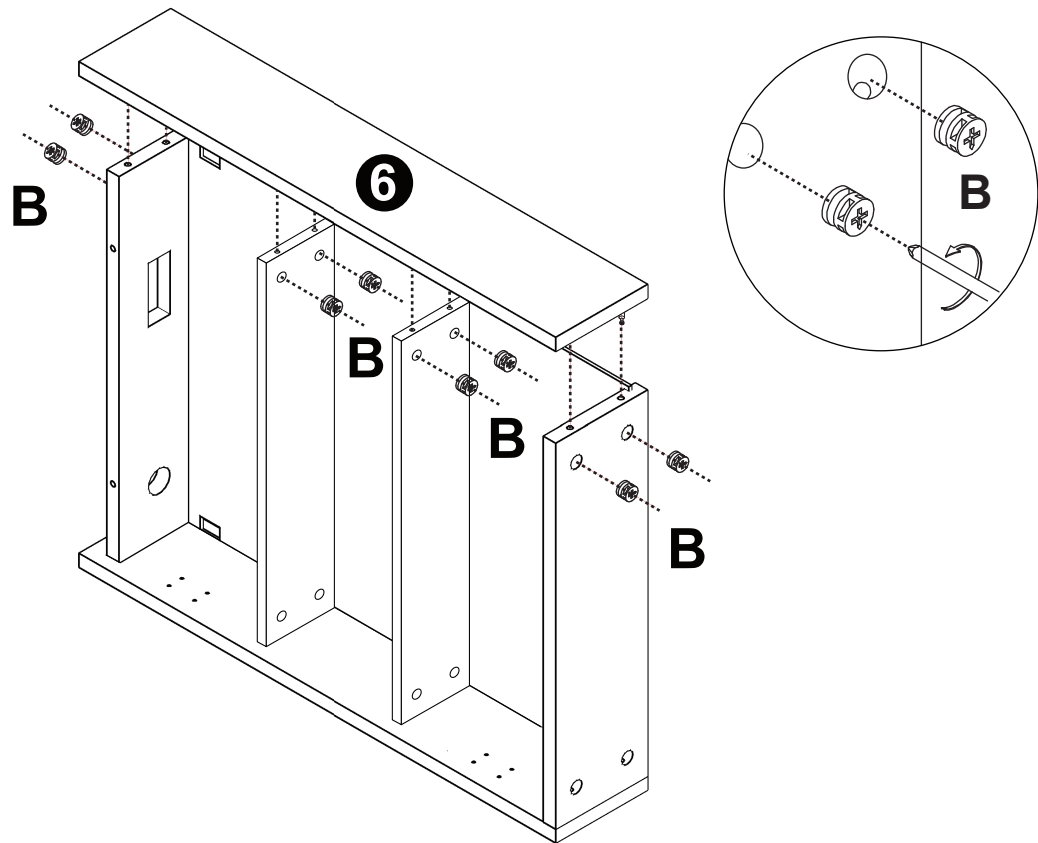
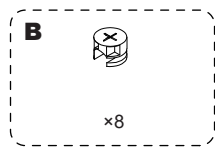

| Step6

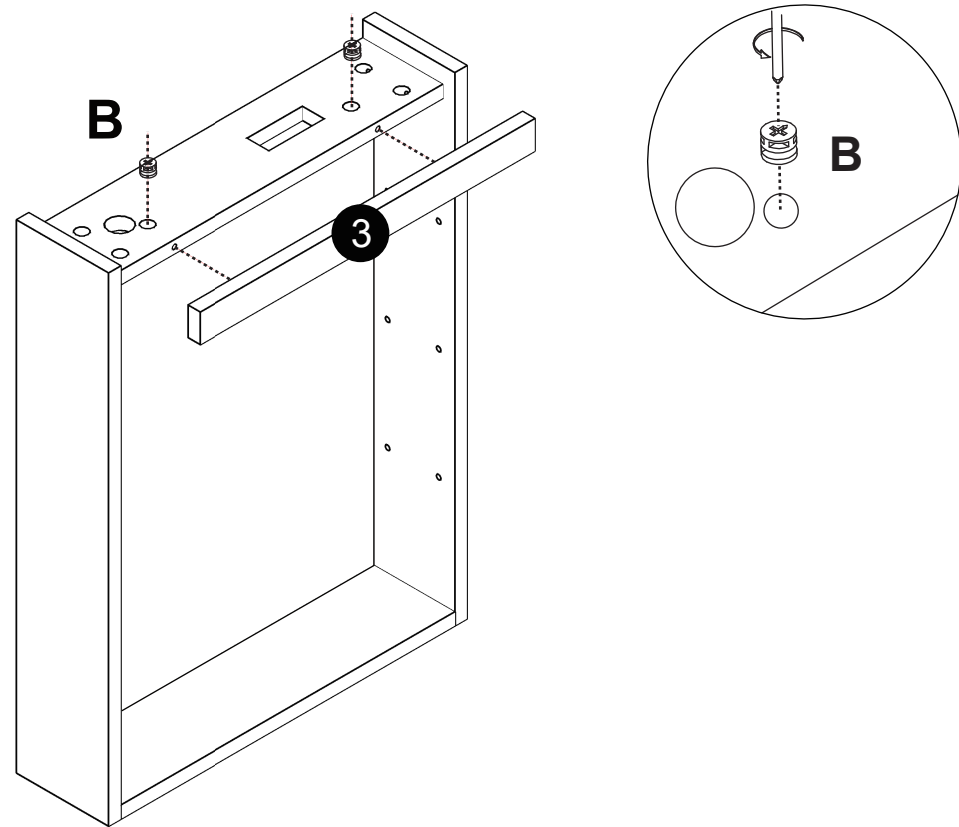

| Step7

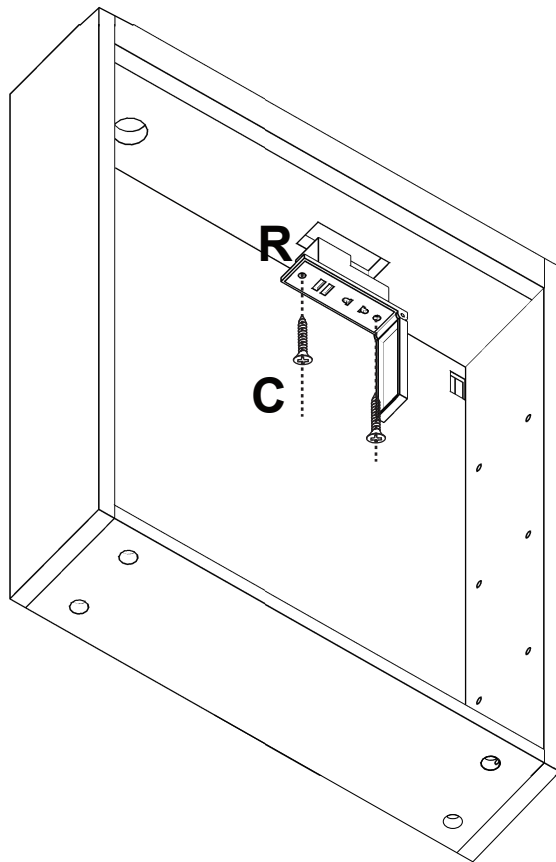
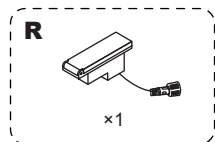
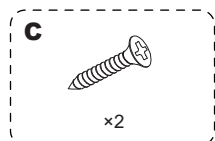

| Step8

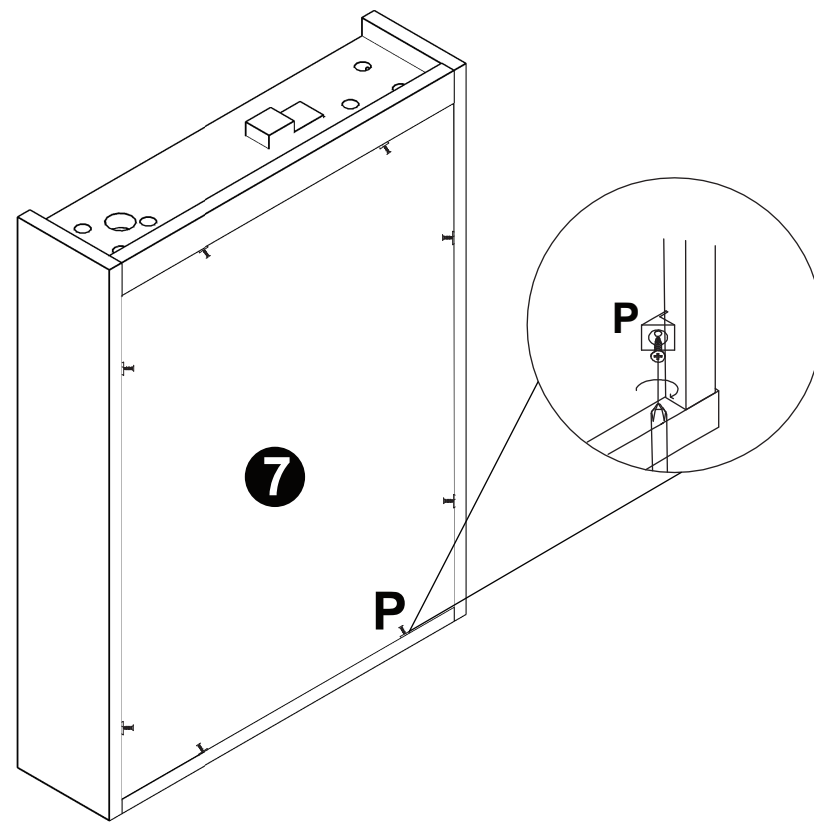
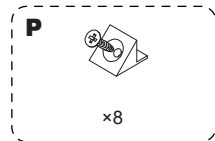

| Step9

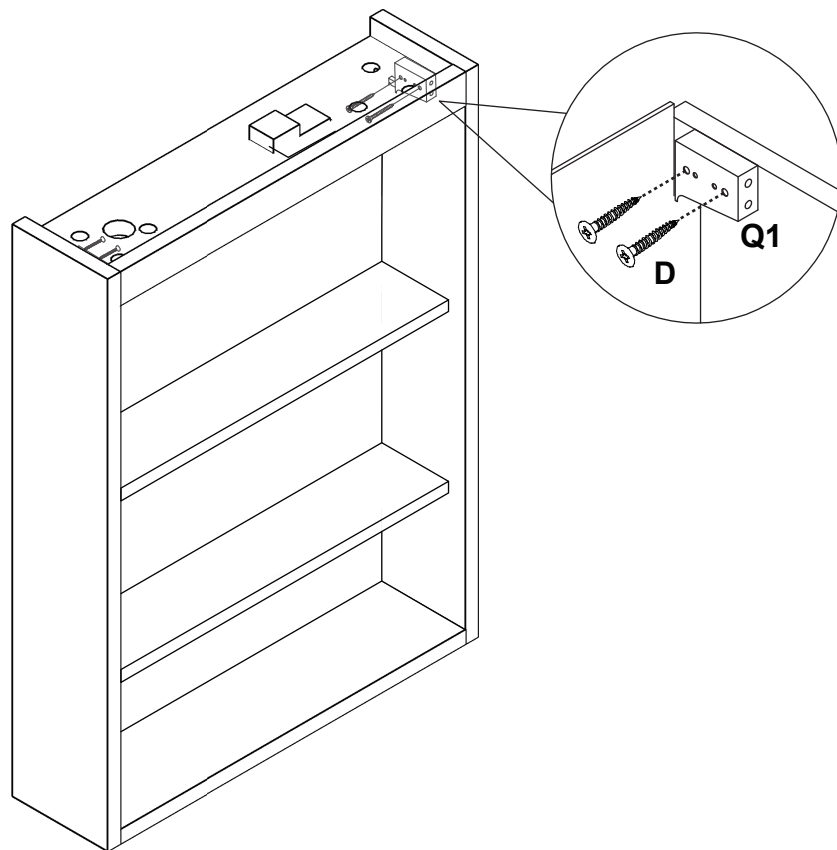
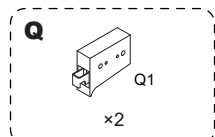
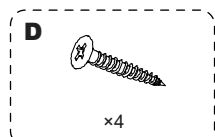

| Step10

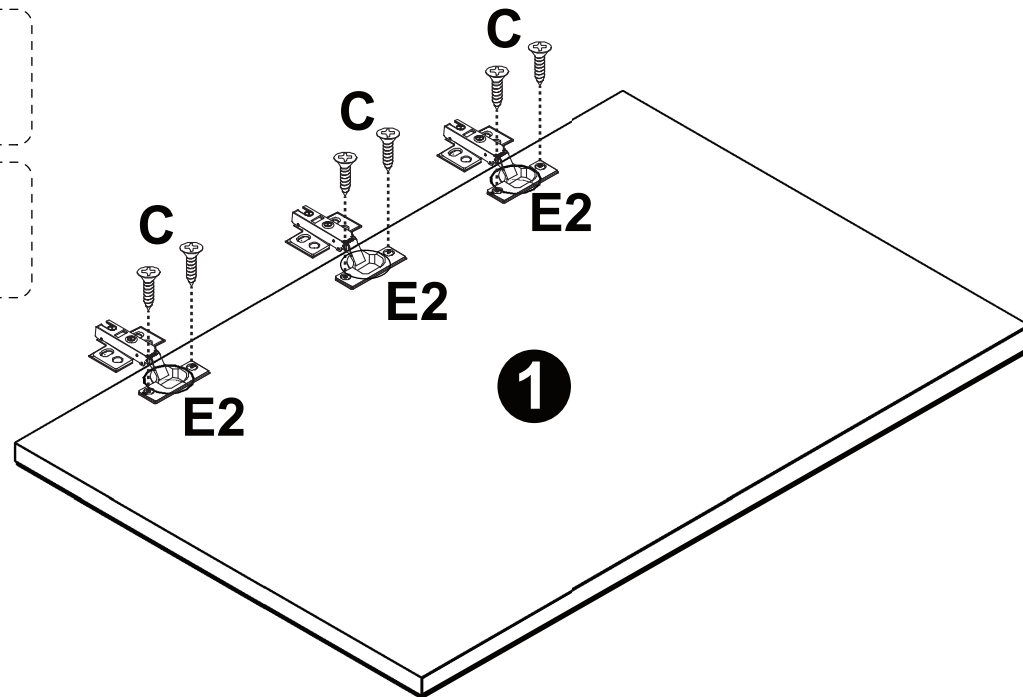
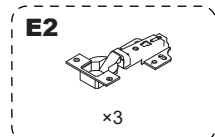
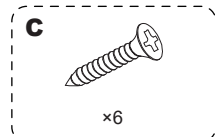

### | Step11

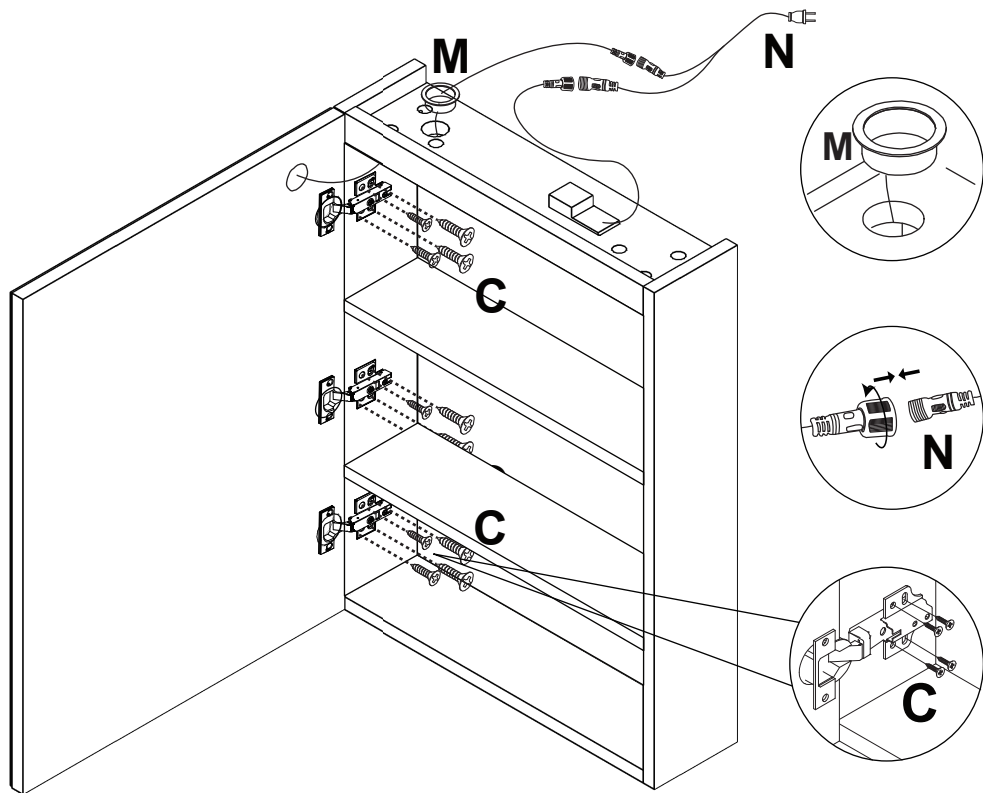
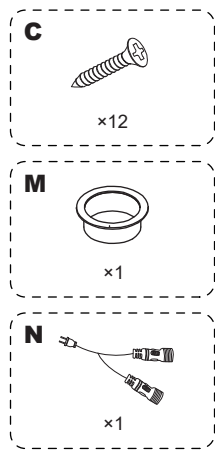

### | Step12

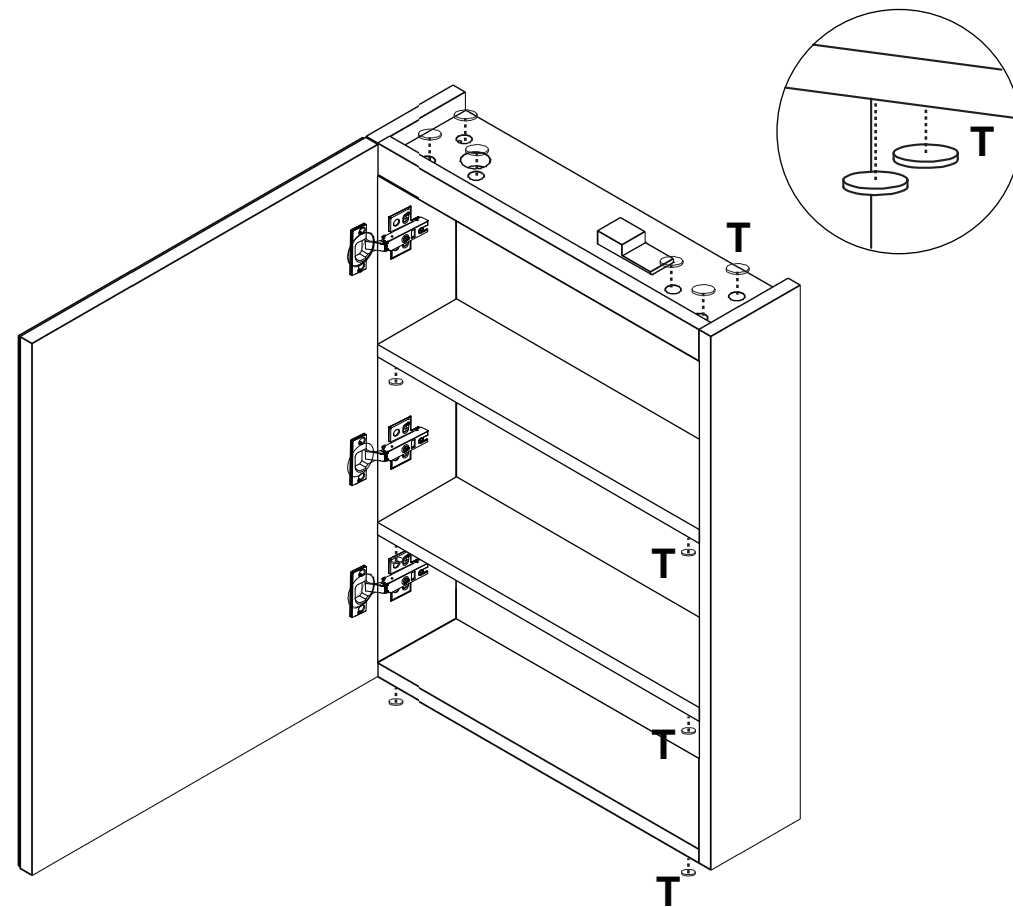
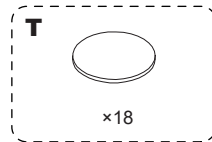

## DOOR ADJUSTMENT/DOOR REMOVAL

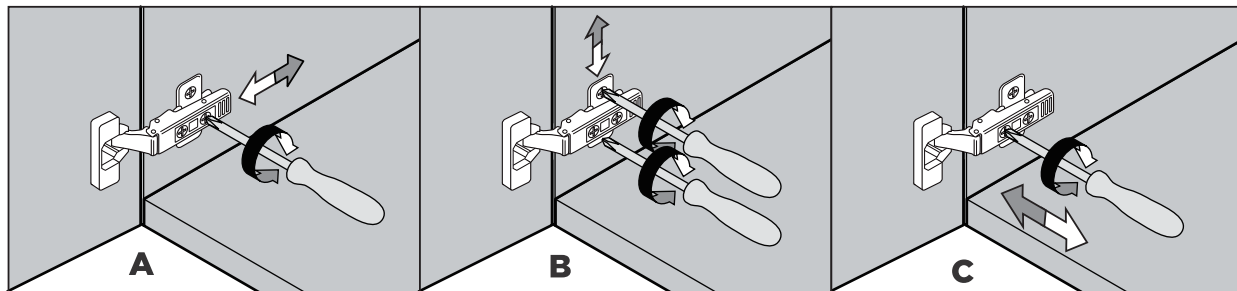
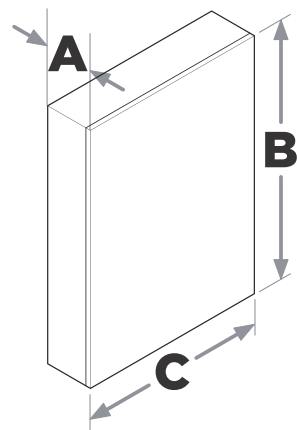

## | Step13-Optional for studs/concrete

Install the cabinet on studs/concrete with cabinet hanger **Q2** and extension screw **F** into predrill hole against the studs/concrete as shown.

**Attention:** Optional install on concrete or studs anchors

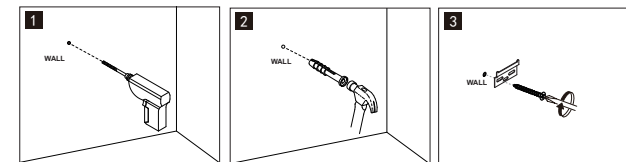
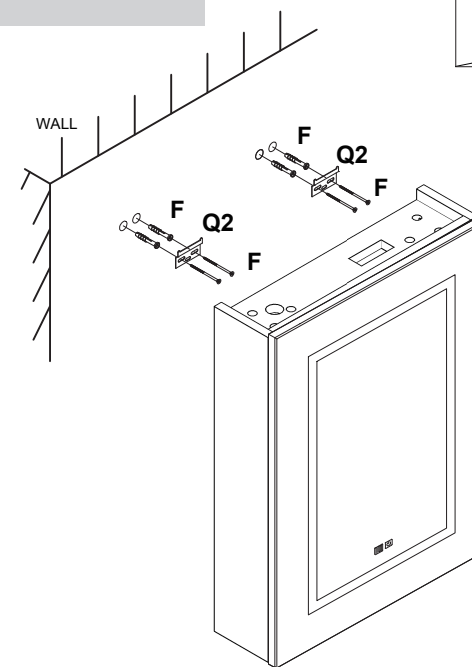
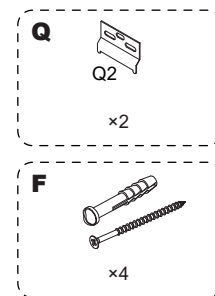

Studs

Concrete

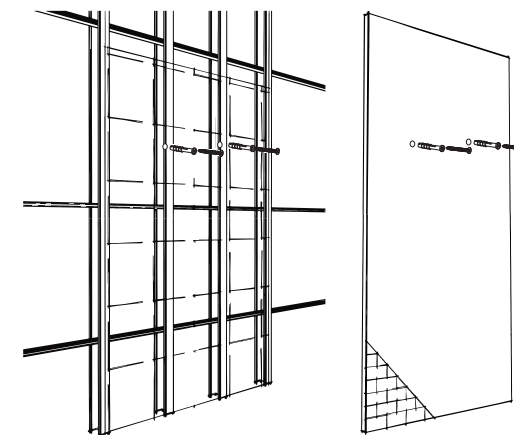

## Step 13-Optional for drywall

Install the cabinet on drywall with cabinet hanger **Q2** and extension screw **F** into predrill hole against the drywall as shown.

**Attention:** Optional install on drywall (sheet wood)

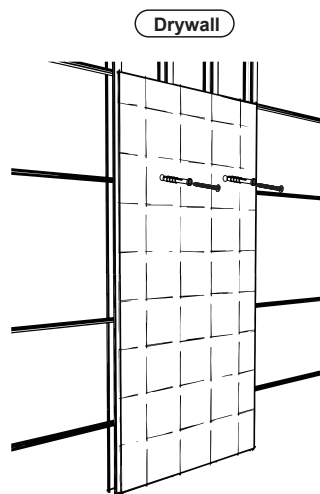
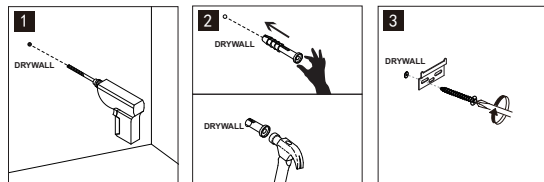
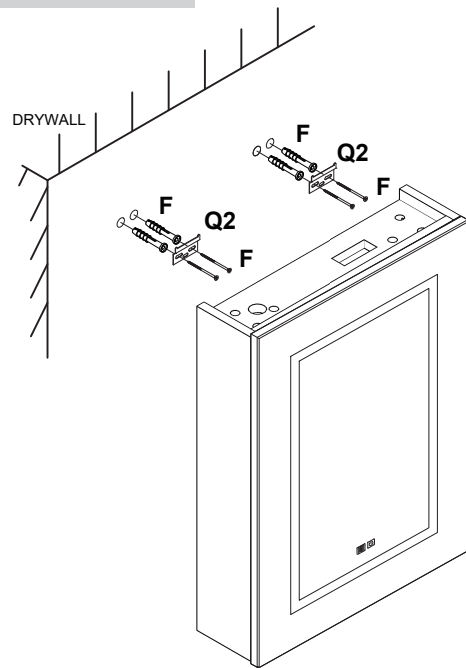
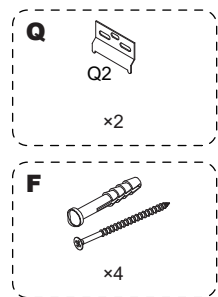

**⚠** If the cabinet does not fit the wall after the hanger is installed, adjust the two cross screws on the back of the hanger.

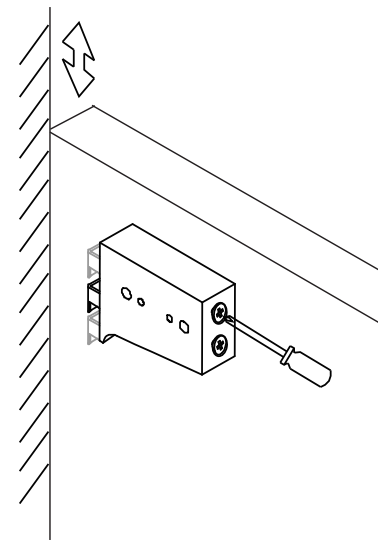
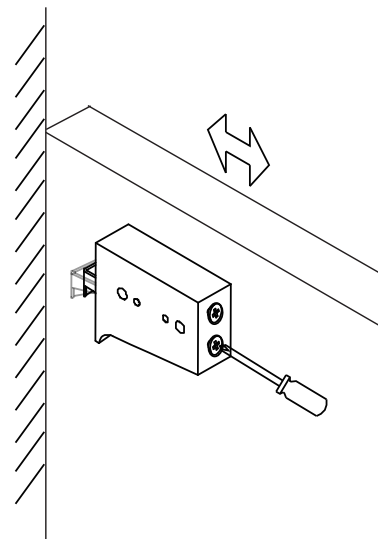

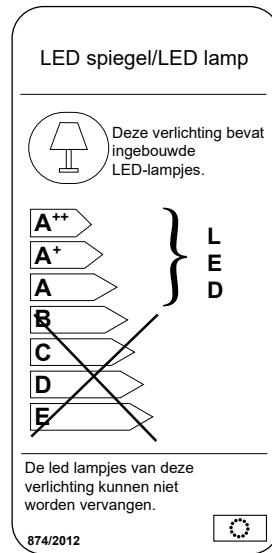
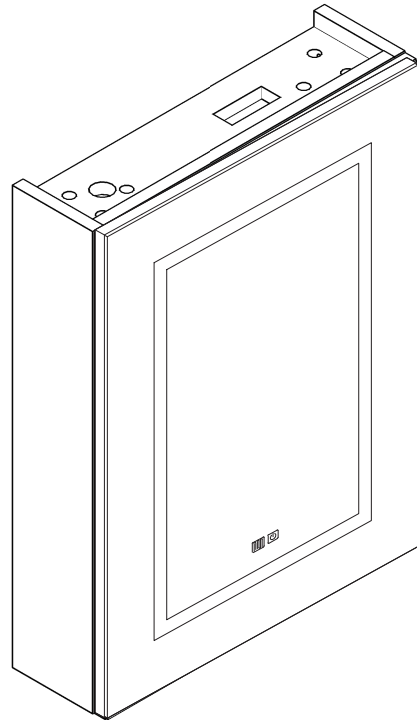

## PRODUCT PARAMETERS



Input voltage:US110V  
DE230V  
UK230V  
Energy Efficiency: A++

## USER MANUAL

-  Right touch sensor  
On/off lighting  
Light temperature change from 2700K to 6500K by holding  
Light brightness change from 10% to 100% by holding
-  Left touch sensor  
On/off anti-fog  
(the defogger power will automatically turn off after an hour)

### 1.How to use dimmer switch

Touch the sensor button to turn on the light

Touch and hold the light ON sensor button to change the light temperature from 2700K to 6500K, release the button, when the light temperature reaches the desired color.

### 2.How to use light memory function

Select a preferred light mode and wait for more than 5 seconds.

Click the on/off button to turn the light off.

When it is turned on again, the light will be the same as when it was last turned off.

### 3.How to use defogger switch

Touch the sensor button to turn on /off the defogger.

Suggestion : Turn off the mirror power supply if you don't use it for a long time.

## FAULT DETECTION AND HANDLING

Faults	Causes	Measures
Broken mirror	Bad package or violent transport	Get replacement or refund by contact us with damaged photos
Cracked/scratched boards	Bad packaging or violent transport	Get replacement or partial refund by contact us with damaged photos
Led light not bright enough	LED lights are only ambient lights, not to be used as lighting	Correctly adjust the colour of the light for the bathroom environment; if it is still not bright enough, additional lighting is required
LED strip does not work / cannot be turned on	No switch on/ wiring connect failure	Check if the power is on or off get a replacement by contact us with faults photos

ON and OFF	Loose wiring	Open the back panel, check the internal wiring check if there is loose wire
Mirror cabinet does not fit the wall	Uneven wall, tilted angle	Adjust the 2 screws on the hanging code, the top screw adjusts the angle of tilt of the mirror cabinet. The bottom screw adjusts the fit between the mirror cabinet and the wall
Door and cabinet cannot be aligned	Incorrect hinge installation	Adjust the hinges, loosen the screws, then align the mirror cabinet door with the door frame and finally tighten all the screws
Cannot be recessed	Plug not cut off or wrong size of niche	Cut the plug and connect it to the wall wire, or check the rough size of niche
Memory function cannot be enabled	The memory function requires a time interval	Select a preferred light mode and wait for more than 5 seconds, touch the on/off button to turn the light off. When it is turned on again, the light will be the same as the last time it was turned off

---

## About us

We have focused on household products design and research for many years. Professional design and warm-hearted service make each staff believe that eco-friendly and cost-effective furniture make warmer home and better life.

### Focus on Furniture, Cherish for People

---

## LIMITED WARRANTY

The furniture team would like to improve customer service quality and make your experience smooth.

Return Policy: We accept returns within 30 days without any significant reason. After we receive the returned item, we will check it and make sure that it is not damaged, then we will process the refund. For more details, please check the above terms of RETURN/DAMAGE CLAIM INSTRUCTIONS.

Any damages, defects and parts missing during installation, please contact us from the very beginning. Replacement, exchange and refund will be arranged ASAP except for personal reasons.

The exceptions or exclusions to this warranty are as follows:

1. We do not accept claims outside of a limited period.
2. This warranty does not include the products purchased by mistake.
3. Any damages, broken parts, missing parts, we will repair or replace them without charging you any cost within a reasonable period. We reserve the right to require damaged parts to be returned to us upon our request.

If you have any questions concerning this warranty, please get in touch with the Customer Service department. Be prepared to provide your name, address, daytime phone number, the product's model and purchase order number, the date of purchase, and the store name. All the information you provided will help us track your order quickly and solve your problem in the shortest time. This warranty gives you specific rights, and you still possess other rights that vary in each case.