



Seating the Way You Want It

Lesro Industries, Inc.
1 Griffin Road South
Bloomfield, CT
06002

Phone
860.243.3226
Fax
860.243.5392
www.lesro.com

Assembly Instructions For Willow Guest, Bariatric, Loveseat and Sofa

Tools required: 9/16" ratchet and Allen wrench (Allen wrench included in hardware pack)

Note: These instructions are intended for various models and configurations. Your products may not look exactly as those shown in the diagrams.

Important: The assembly process requires that some hardware be kept loose until later in the sequence. Follow these instructions closely to ensure correct assembly.

Recommendation: Retighten all bolts on a seasonal basis to ensure your product remains strong and stable for many years of use.

Weight Capacities: Guest chairs in this series have a weight capacity of **400 lbs.**, Bariatric and Loveseat **600 lbs.**, and sofa **700 lbs.**, unless otherwise stated.

1. Unpack and identify all parts.
2. Attach back to seat using 5" hex bolts and washers into threaded inserts, as shown in figure 1. Keep bolts slightly loose.
3. Carefully align edges of seat with edges of back and tighten bolts securely.
4. Attach legs to bottom of seat using 1/2" Allen bolts into threaded inserts, as shown in figures 2 and 3. Only 3 bolts per leg. Tighten very securely.
5. If your chair is armless, it is fully assembled and ready to use. Otherwise, proceed to next section to attach arms.

Section 1 - Willow Seating *without* Arms

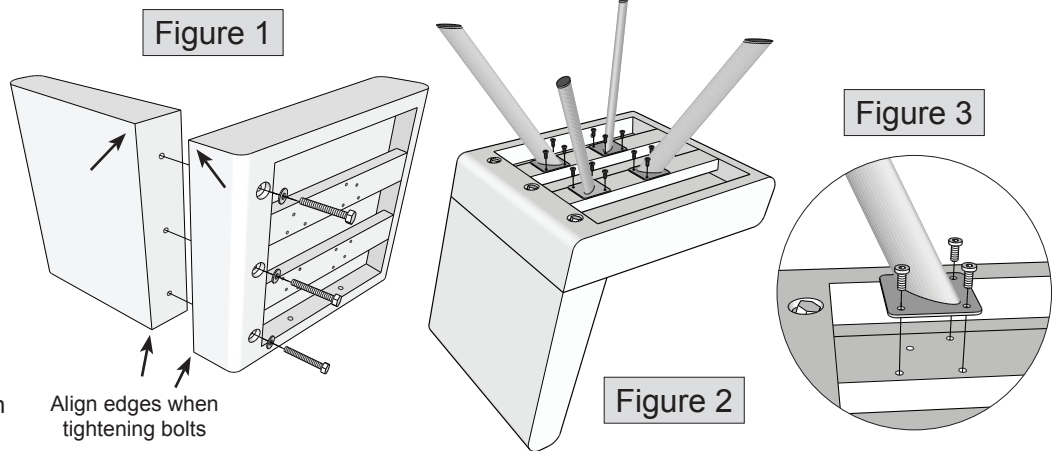

1. Follow steps in Section 1 to attach back and legs to seat.
2. The arms attach to the back assembly using a post-and-keyhole system, as shown in figure 4
3. With the chair in the upright position, attach arm panels by inserting post into keyhole slot, as shown in figure 5. With posts fully inserted, press arm panel down until post "bottoms out" in the keyhole slot.
4. **Important:** Thick fabric can make it difficult to fully insert the posts into the keyhole slots. If this problem occurs, press the arm tightly against the back to compress the fabric. This will enable the post to drop deep enough into the keyhole slot.
5. Once post is fully inserted and correctly positioned inside slot, use 2" hex bolts and washers into threaded inserts, as shown in figure 6. Start each bolt first, until both have caught a few threads, then finger tighten only.
6. Carefully align bottom and back edges of arm with seat and back edges, then tighten bolts securely.
7. Your seating is now assembled and ready to use.

Section 2 - Seating *with* Arms

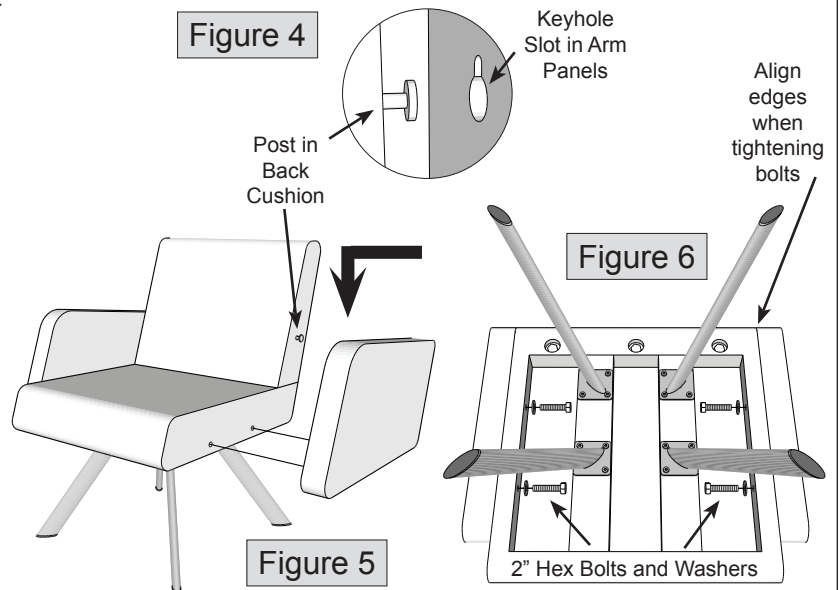

Thank you for purchasing a Lesro product.

Need assistance with assembly? Call Lesro customer service 1-800-275-7545.

Visit us on-line at www.lesro.com