

SWAROVSKI LIGHTING WORLDWIDE

NORTH AND SOUTH AMERICA

Swarovski Lighting
61 Industrial Boulevard
Plattsburgh, New York 12901-1908
USA
Tel. +1 518 563 7500
Fax. +1 518 563 4228
info@swarovski-lighting.com

AFRICA / NEAR EAST / ASIA / PACIFIC

Swarovski Middle East FZE
P.O. Box 17128
Jebel Ali Free Zone R/A 6
Dubai
UAE
Tel. +971 / 4 / 881 / 65 62
Fax. + 971 / 4 / 881 56 23
lighting.me@swarovski.com

Swarovski Greater China Limited
Swarovski Lighting - Asia Pacific
9/F Fortis Tower, 1063 King's Road,
Quarry Bay, Hong Kong
Tel. +852 2969 6435
Fax. +852 2979 1029
lighting.ap@swarovski.com

EUROPE

Swarovski International Distribution AG
Dröschstrasse 15
FL-9495 Triesen
Principality of Liechtenstein
Tel. +423 / 399 / 5656
Fax. +423 / 399 / 6666
lighting.europe@swarovski.com

GERMANY
Tel. +800 / 42 / 22000
Fax. +423 / 399 / 6666

AUSTRIA
Tel. +43 / 5224 / 500 5656
Fax. +43 / 5224 / 500 5666

FRANCE
Tel. +33 / 1 / 44 76 15 53
Fax. +33 / 1 / 44 76 15 54

GREATBRITAIN
Tel. +44 / 845 / 607 0341
Fax. +44 / 845 / 607 0342



CRYSTAL EMPIRE SCE131DN- _____

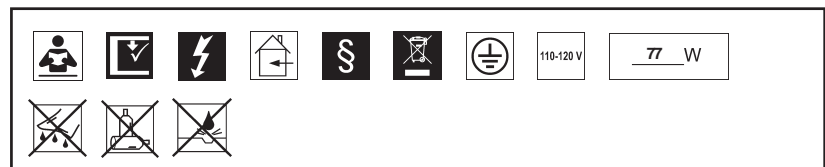
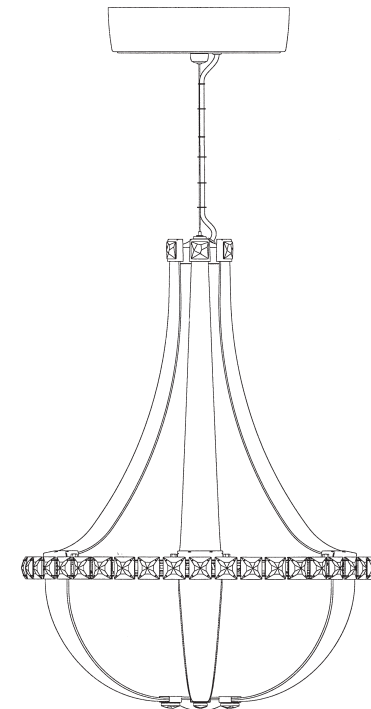

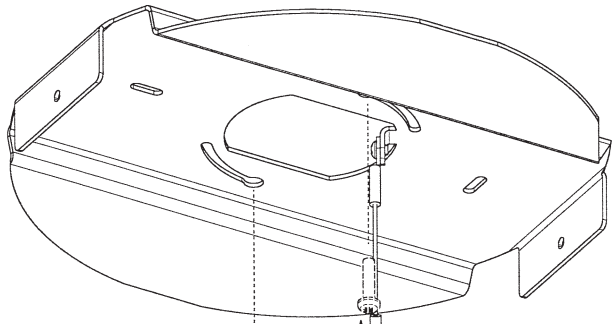

1



40lbs.

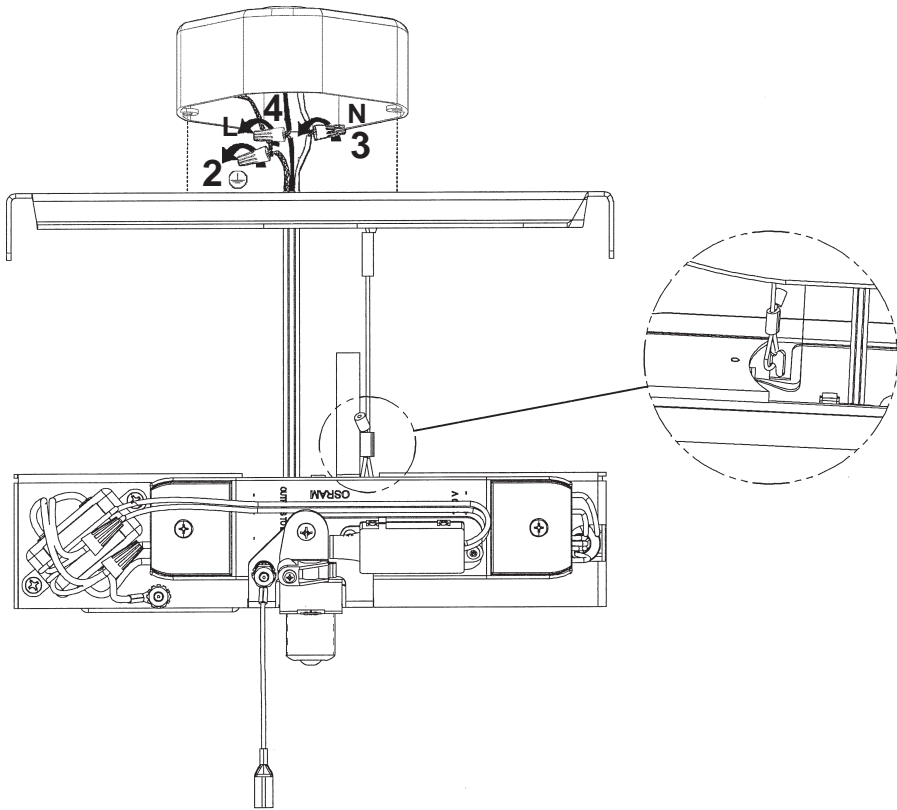

1 X  : 1763

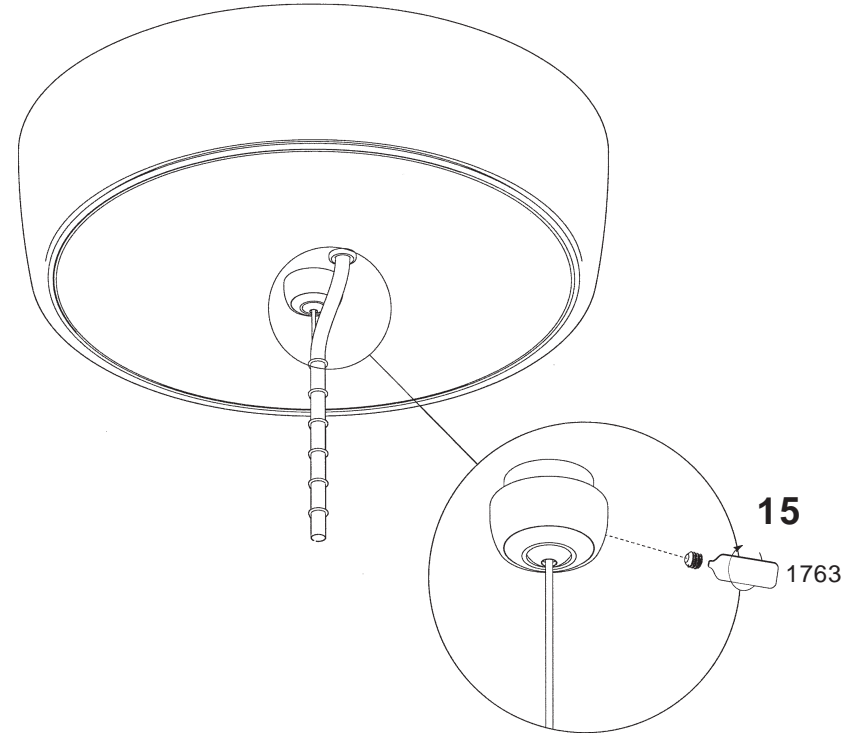

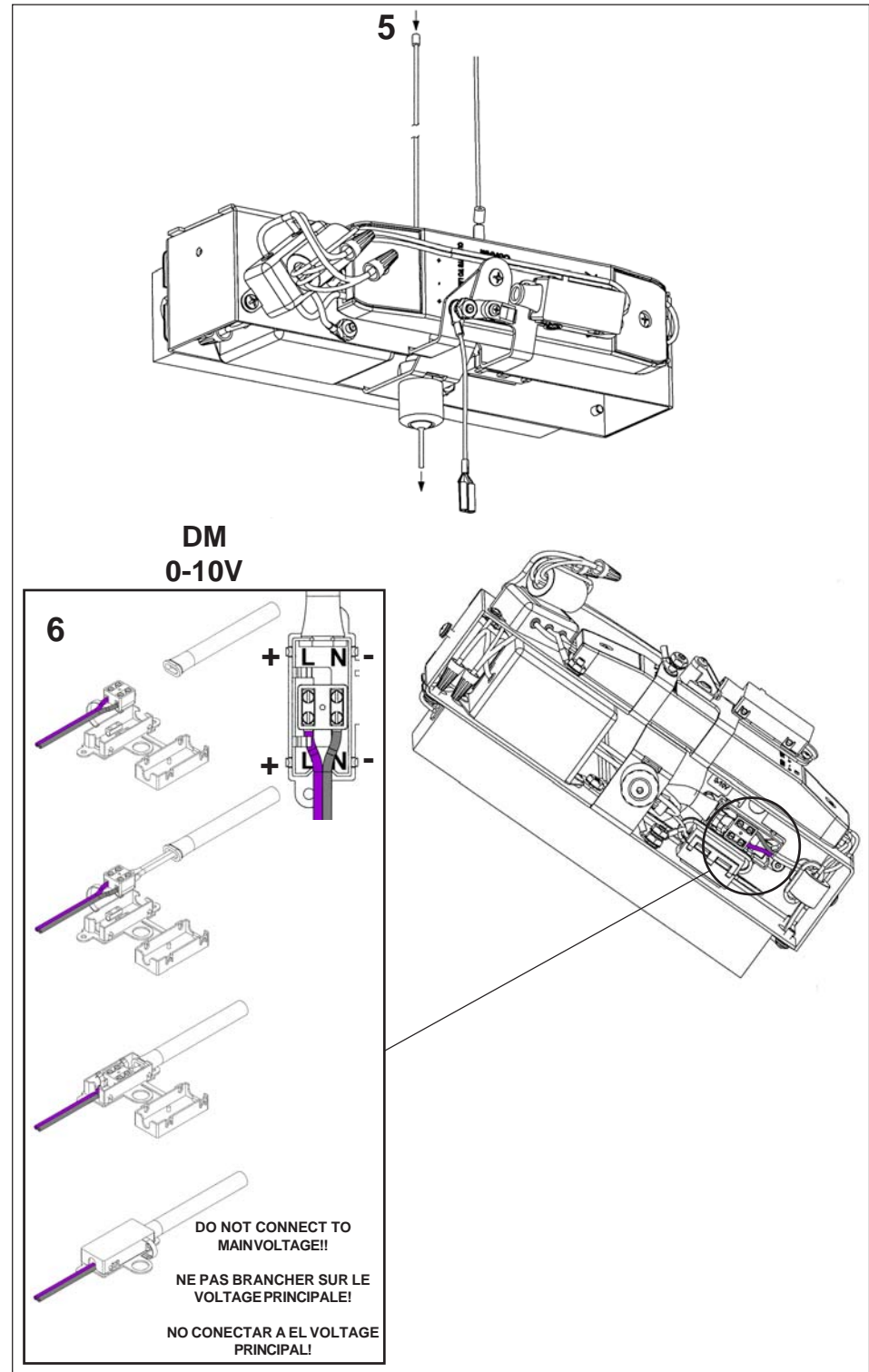
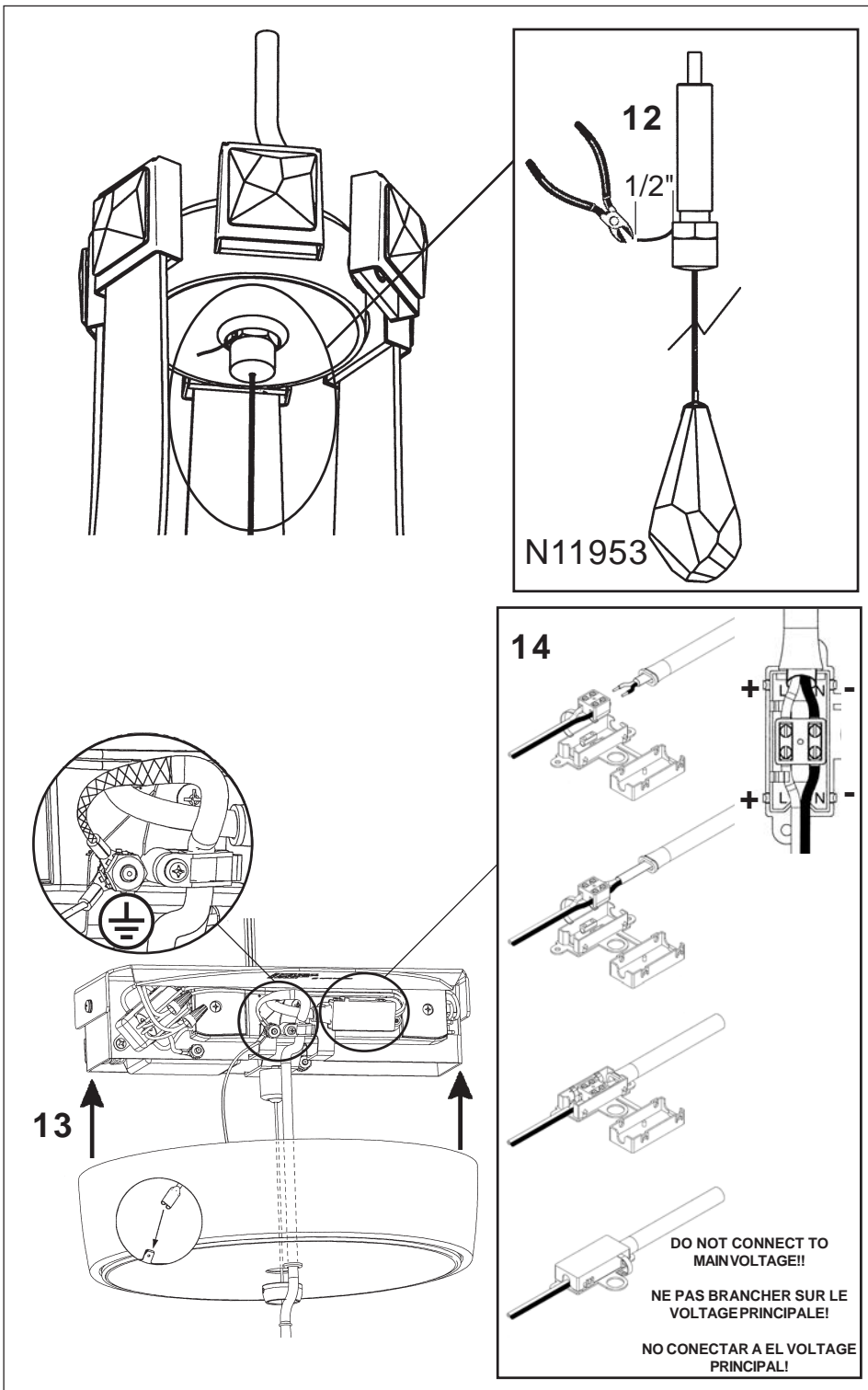

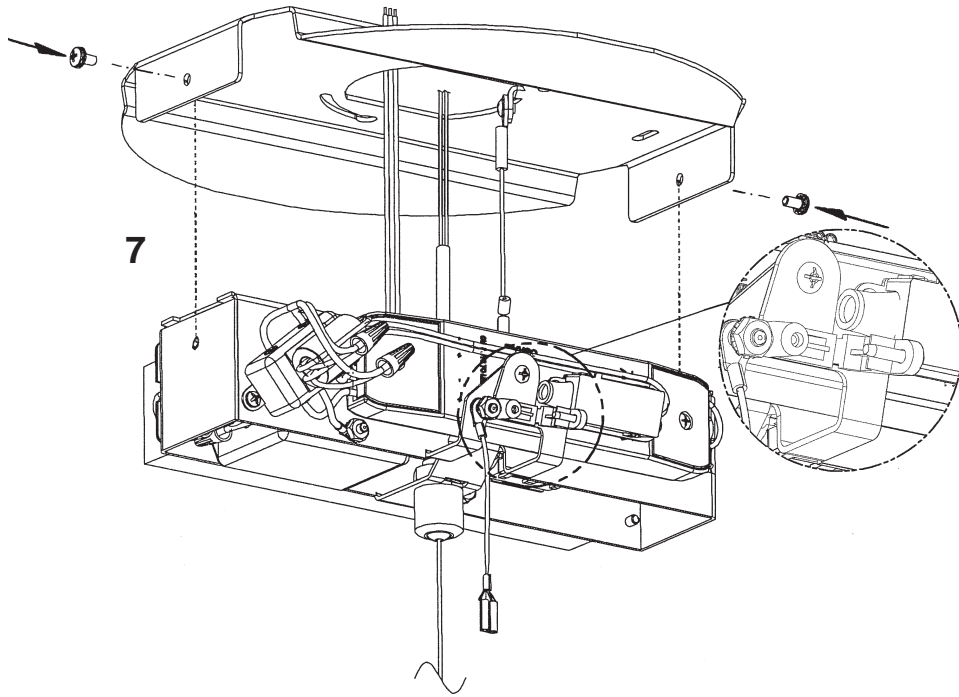

7

27 X  : 30799

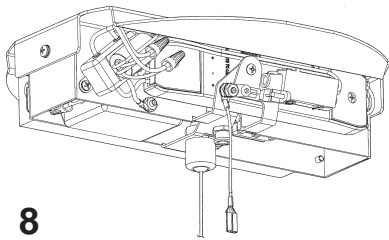

8

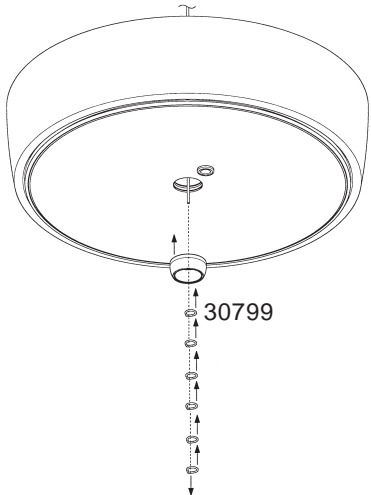

30799

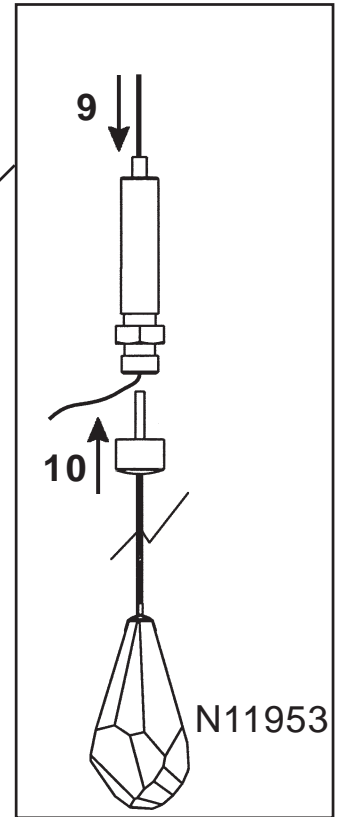
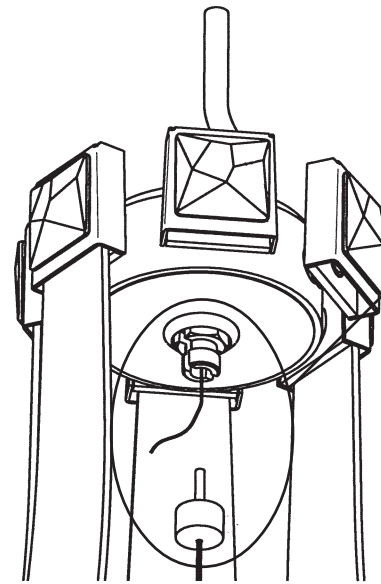

N11953

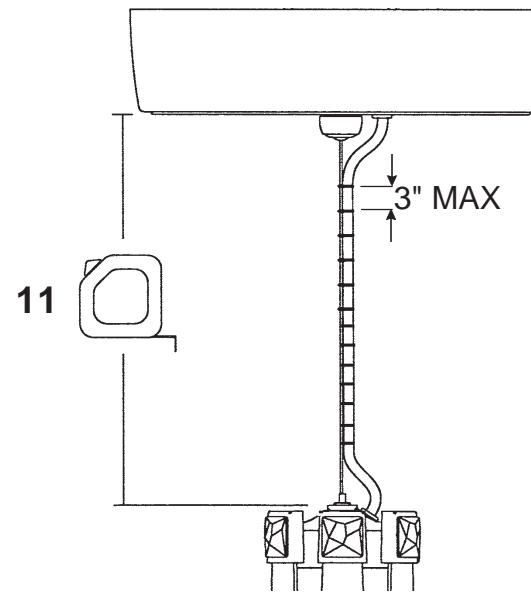

3" MAX

11