

NOTICE

- *Please make sure that you have all parts indicated and they are in good condition before you begin assembly of this item. Refer to part list and hardware list below for guidance.
- *This item should be assembled on a soft surface to prevent scratching the finish during assembly.
- * This item may require periodic tightening.

Product Dimensions:30" W x 30.5" D x 36.5" H

PREPARATION





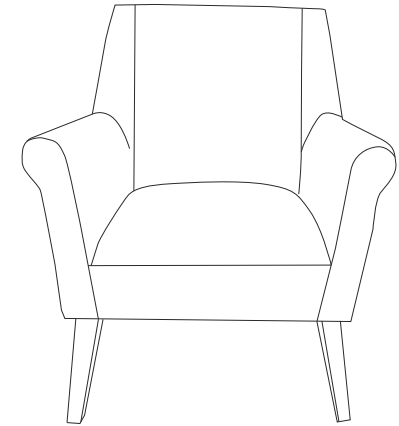

- *Before beginning assembly of product , make sure all parts are present . Compare parts with part contents list and hardware contents list.
- *If any part is missing or damaged , do not attempt to assemble the product.
- *Estimated Assembly Time: 10 minutes.
- *Tolls Required for Assembly (included) : Allen Key

CARE AND MAINTENCE

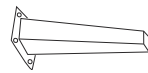
- *Spot clean using a mild water-free solvent.
- * Only a professional cleaner should undertake a complete overall cleaning.
- *The use of steam or water-based cleaners may cause excessive shrinking or staining.



Part List and Hardware List

PIECE	DESCRIPTION	PICTURE	QUANTITY
A	Seat Body		1X
B	Front Legs		2X
C	Rear Legs		2X
HW1	Allen bolt : M6 x 1 x 25mm		16X
HW2	Spring Washer : M6		16X
HW3	Flat Washer : M6x18mm		16X
HW4	Allen Key		1X



Weight Capacity: 275 lbs

WARNING: DO NOT STAND ON CHAIR

WARNING: DO NOT OVER TORQUE BOLTS/SCREWS

PREPARATION

*Before beginning assembly of product , make sure all parts are present . Compare parts with part contents list and hardware contents list.

*If any part is missing or damaged , do not attempt to assemble the product.

*Estimated Assembly Time: 10 minutes.

*Tolls Required for Assembly (included) : Allen Key

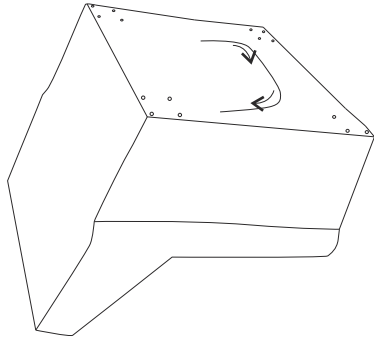

STEP 1: OPEN THE ZIPPER ON THE UNDERSIDE OF THE SEAT AND TAKE OUT LEGS AND HARDWARE.

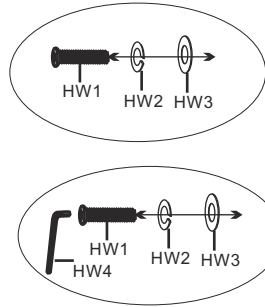

STEP 2: PUT THE WASHERS ON THE BOLT IN THE ORDER SHOWN IN THE PICTURE.

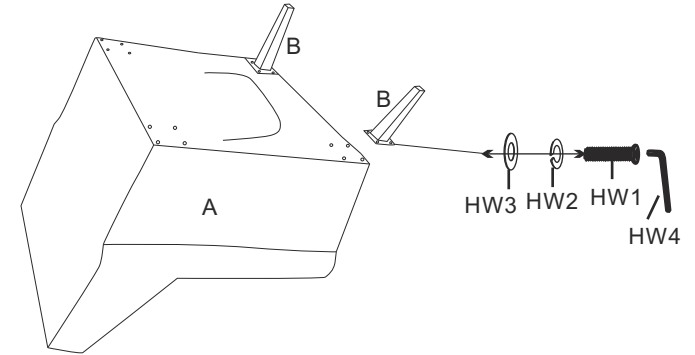

STEP 3: ASSEMBLY THE FRONT LEGS AND SCREW IN THE BOLTS. BUT DON'T TIGHTEN COMPLETELY.

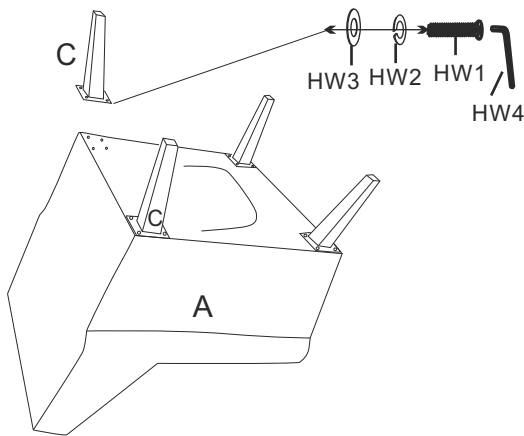

STEP 4: ASSEMBLY THE REAR LEGS AND SCREW IN THE BOLTS. BUT DON'T TIGHTEN COMPLETELY.

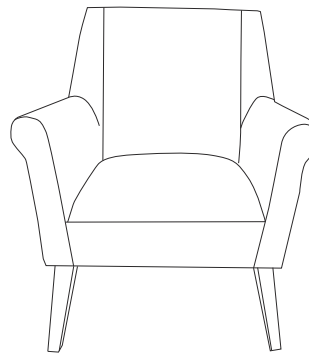

STEP 5: PUT THE CHAIR UPRIGHT AND MAKE SURE ALL LEGS ARE LEVEL, THEN FIRMLY TIGHTEN BOLTS WITH ALLEN KEY WHILE THE CHAIR IS UPRIGHT AS PICTURED ABOVE.

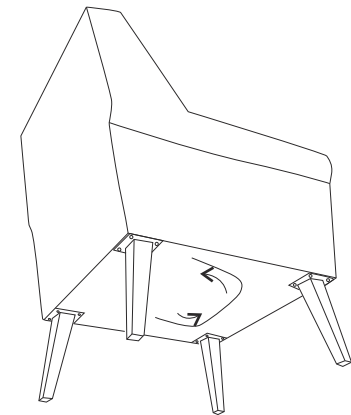

STEP 6: ZIP THE COVER ON BOTTOM OF SEAT. THIS ITEM MAY REQUIRE PERIODIC TIGHTENING.