

# Montageanleitung | Instructions de montage

## Assembly Instructions | Instrucciones de montaje

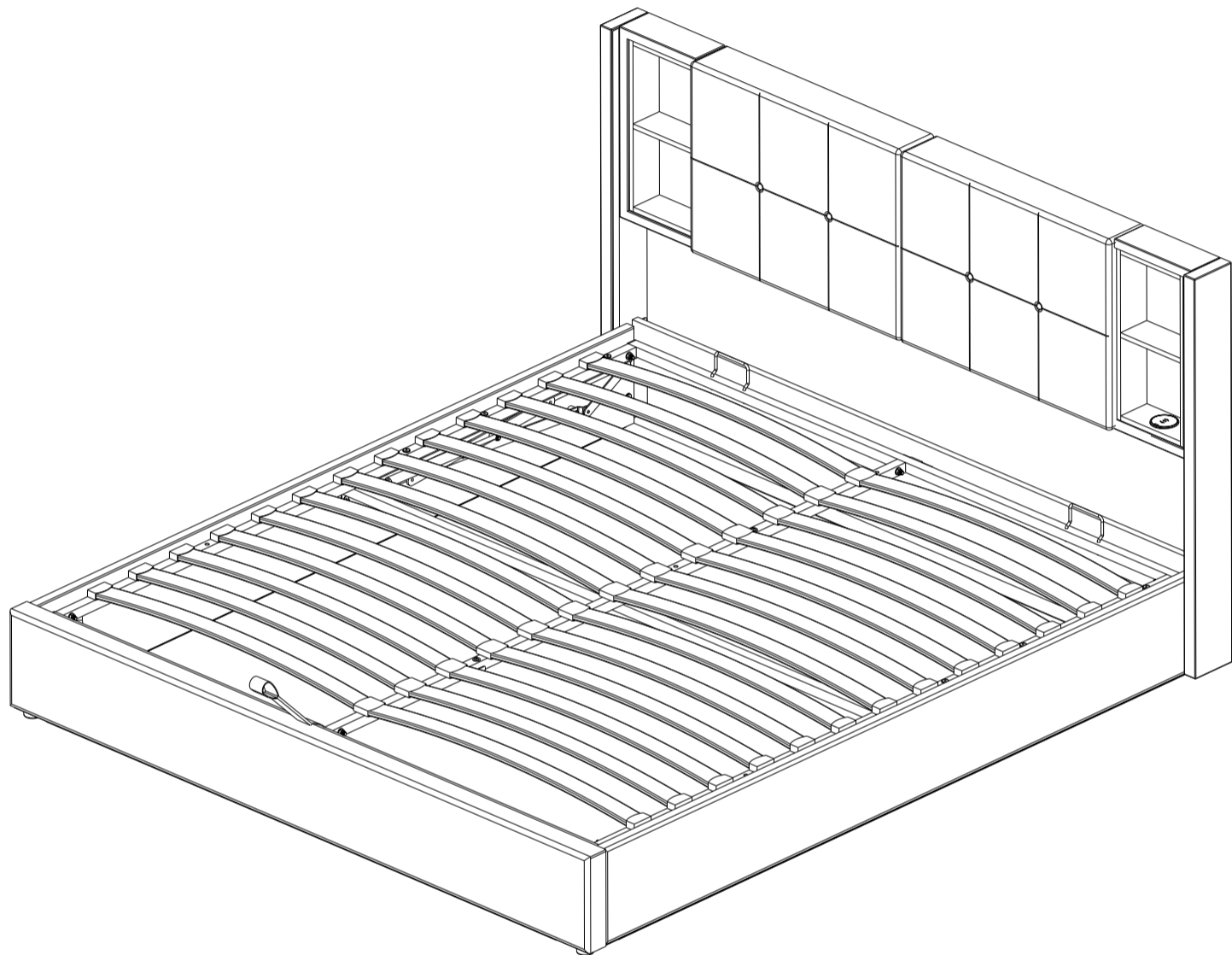

**GB** This set comes in 2 boxes. If you do not receive a full set of 2 boxes, please contact our customer service.

**DE** Dieses Set wird in 2 Schachteln geliefert. Wenn Sie nicht ein komplettes Set von 2 Boxen erhalten, kontaktieren Sie bitte unseren Kundenservice.

**FR** Ce set est livré en 2 boîtes. Si vous ne recevez pas un jeu complet de 2 boîtes, veuillez contacter notre service clientèle.

## English

### IMPORTANT FOR GAS LIFT BEDS & MAINTAINCE

- Please place the mattress on top of the bed frame.
- Please do not pull on the strap handles.
- Please press heavily to release the compressed gas.
- Periodically check all screw & fixings to ensure they are secure.
- When moving your product, carefully lift into place.
- Wipe clean with a slightly damp cloth- please do not use abrasive chemicals or bleach.
- Do NOT allow children to operate the lift mechanism.
- Do NOT allow children near the lift base when operating the mechanism.
- Do NOT stand inside the bed or the internal storage base.
- Do NOT overload the internal storage base.
- DO NOT jump on the product or any of its parts.

## Deutsch

### WICHTIG FÜR GASLIFT-BETTEN & WARTUNG

- Bitte legen Sie die Matratze oben auf den Bettrahmen.
- Bitte ziehen Sie nicht an den Gurtgriffen.
- Bitte drücken Sie kräftig, um das komprimierte Gas freizusetzen.
- Überprüfen Sie regelmäßig alle Schrauben und Befestigungen, um sicherzustellen, dass sie sicher sind.
- Wenn Sie Ihr Produkt bewegen, heben Sie es vorsichtig an seinen Platz.
- Mit einem leicht feuchten Tuch abwischen - bitte keine scheuernden Chemikalien oder Bleichmittel verwenden.
- Erlauben Sie Kindern NICHT, den Hebemechanismus zu bedienen.
- Lassen Sie Kinder NICHT in die Nähe des Liftsockels, wenn Sie den Mechanismus bedienen.
- Stellen Sie sich NICHT in das Bett oder in die Innenablage.
- Überlasten Sie den internen Liftsockel NICHT.
- Springen Sie NICHT auf das Produkt oder eines seiner Teile.

## Français

### IMPORTANT POUR LES LITS À RELEVAGE DE GAZ & MAINTENANCE

- Veuillez placer le matelas sur le dessus du cadre de lit.
- Ne tirez pas sur les poignées de la sangle.
- Appuyez fortement pour libérer le gaz comprimé.
- Vérifiez régulièrement que toutes les vis et fixations sont bien en place.
- Lorsque vous déplacez votre produit, soulevez-le avec précaution pour le mettre en place.
- Nettoyez avec un chiffon légèrement humide - n'utilisez pas de produits chimiques abrasifs ou d'eau de Javel.
- Ne laissez pas les enfants utiliser le mécanisme de levage.
- Ne laissez pas les enfants s'approcher de la base de levage lorsqu'ils actionnent le mécanisme.
- Ne vous tenez PAS à l'intérieur du lit ou de la base de stockage interne.
- Ne surchargez pas la base de stockage interne.
- Ne pas sauter sur le produit ou l'une de ses parties.

## Italiano

### IMPORTANTE PER I LETTI CON SOLLEVAMENTO A GAS E LA MANUTENZIONE

- Posizionare il materasso sopra la struttura del letto.
- Non tirare le maniglie della cinghia.
- Premere con forza per rilasciare il gas compresso.
- Controllare periodicamente tutte le viti e i fissaggi per assicurarsi che siano saldi.
- Quando si sposta il prodotto, sollevarlo con cautela.
- Pulire con un panno leggermente umido, senza usare prodotti chimici abrasivi o candeggina.
- NON permettere ai bambini di azionare il meccanismo di sollevamento.
- NON permettere ai bambini di avvicinarsi alla base di sollevamento quando si aziona il meccanismo.
- NON sostare all'interno del letto o della base di contenimento interna.
- NON sovraccaricare la base di contenimento interna.
- NON saltare sul prodotto o sulle sue parti.

## Español

### IMPORTANTE PARA LAS CAMAS ELEVADORAS DE GAS & MANTENIMIENTO

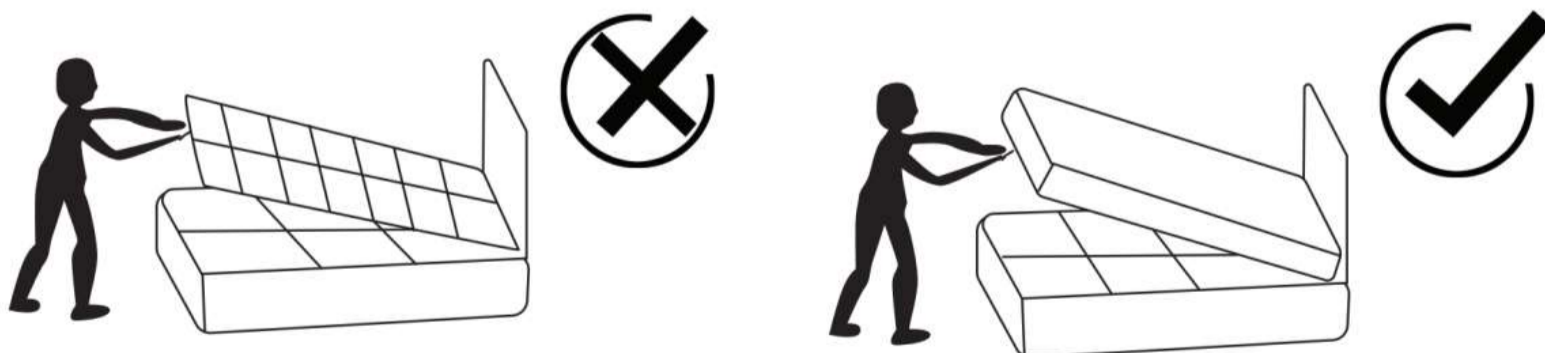

- Coloque el colchón sobre el somier.
- No tire de las asas de la correa.
- Presione con fuerza para liberar el gas comprimido.
- Compruebe periódicamente que todos los tornillos y fijaciones estén bien sujetos.
- Al mover el producto, levántelo con cuidado para colocarlo en su sitio.
- Limpie con un paño ligeramente humedecido; no utilice productos químicos abrasivos ni lejía.
- NO permita que los niños accionen el mecanismo de elevación.
- NO permita que los niños se acerquen a la base elevadora cuando accionen el mecanismo.
- NO se ponga de pie dentro de la cama o de la base de almacenamiento interna.
- NO sobrecargue el somier.
- NO salte sobre el producto ni sobre ninguna de sus piezas.

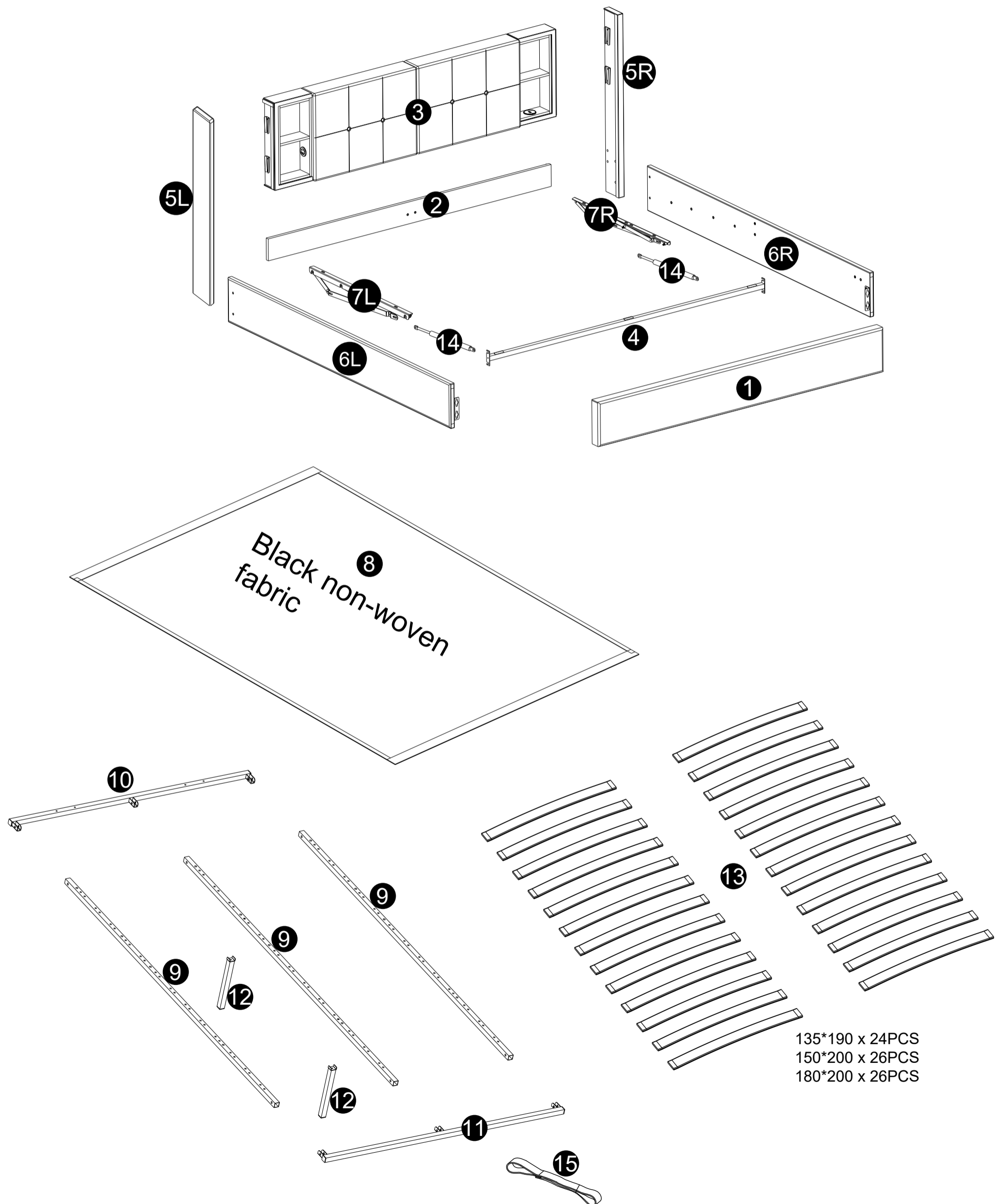

# Stückliste

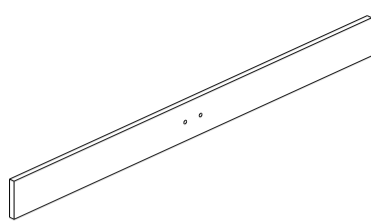
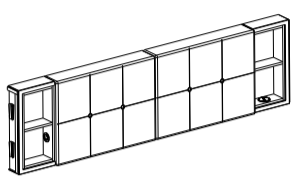
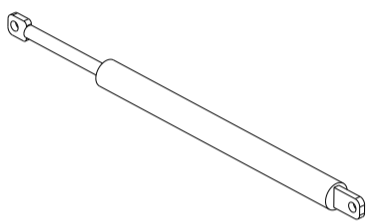

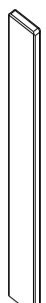
2		X1
3		X1
14		X2

5L		X1
5R		X1

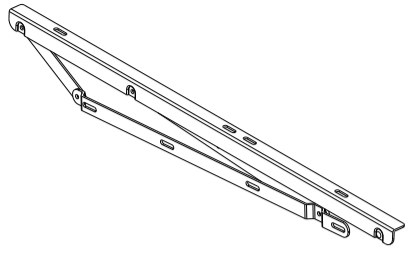
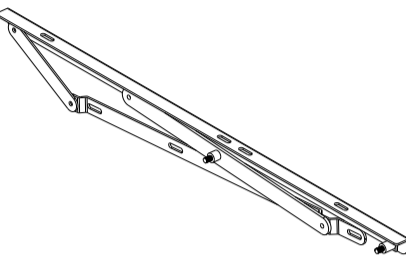

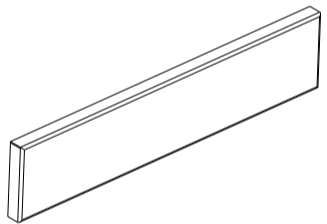
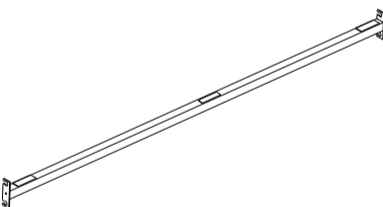
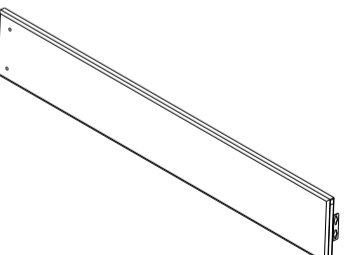
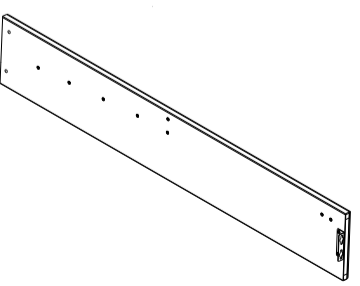

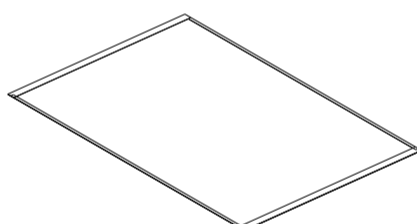
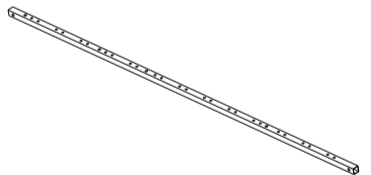
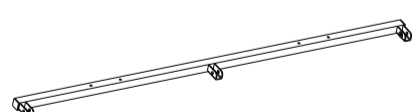
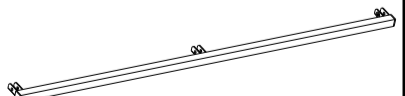
7L		X1
7R		X1

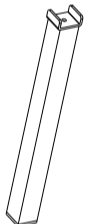
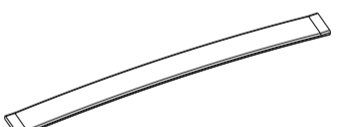
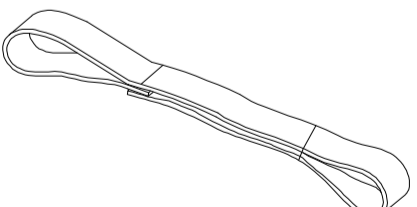
1		X1
4		X1
6L		X1
6R		X1

8		X1
9		X3
10		X1
11		X1

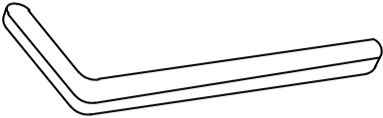
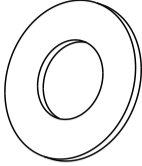
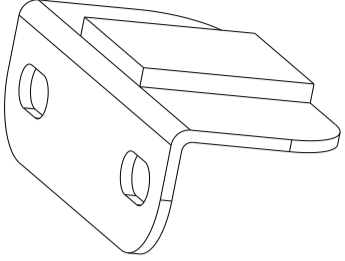
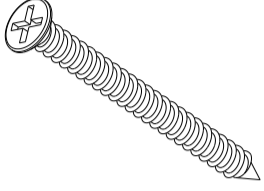
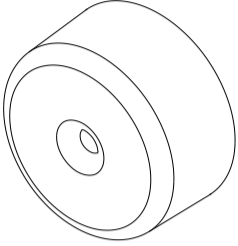
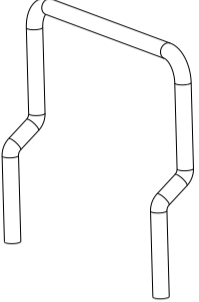
12		X2
13	 135*190 x 24PCS 150*200 x 26PCS 180*200 x 26PCS	
15		X1

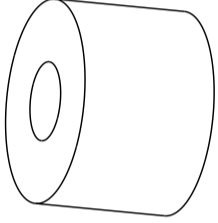
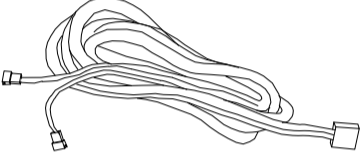
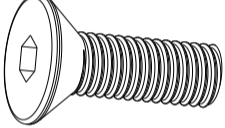
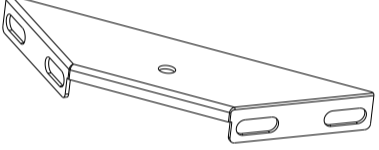
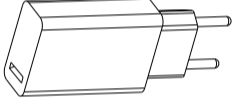
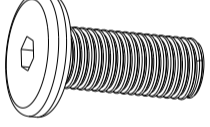
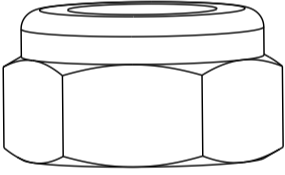
# Hardware List-Hardware-Liste-Liste du matériel

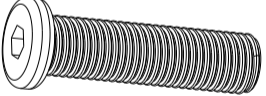
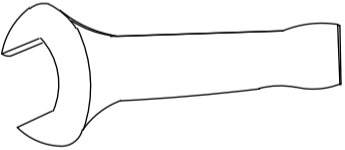
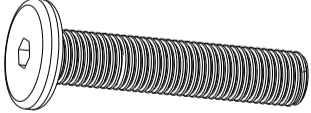
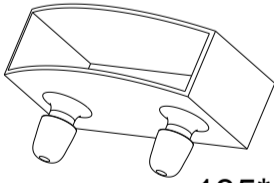
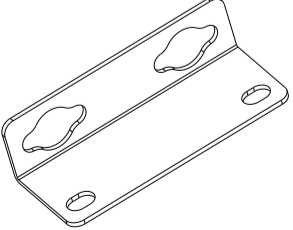
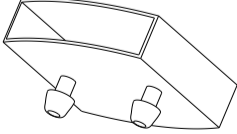
<b>A</b>		X1	<b>J</b>		X12	<b>S</b>		X2
<b>B</b>	 M4x40mm	X2	<b>K</b>		X2	<b>T</b>		X2
<b>C</b>	 M6x35mm	X2	<b>L</b>		X8	<b>U</b>		X1
<b>D</b>	 M8x18mm	X4	<b>M</b>		X2	<b>V</b>		X1
<b>E</b>	 M8x20mm	X32	<b>N</b>	 M8	X16	<b>W</b>		X4
<b>F</b>	 M8x30mm	X8	<b>P</b>		X1			
<b>G</b>	 M8x40mm	X16	<b>Q</b>	 135*190 x 24PCS 150*200 x 26PCS 180*200 x 26PCS				
<b>H</b>		X2	<b>R</b>	 135*190 x 12PCS 150*200 x 13PCS 180*200 x 13PCS				

1

A x 1



E x 4



M8 x 20mm

H x 2

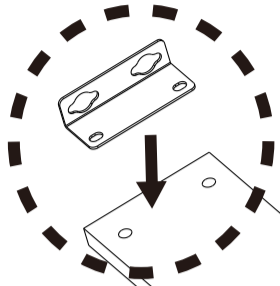
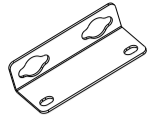

2

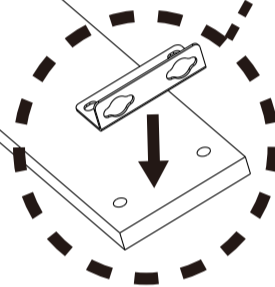
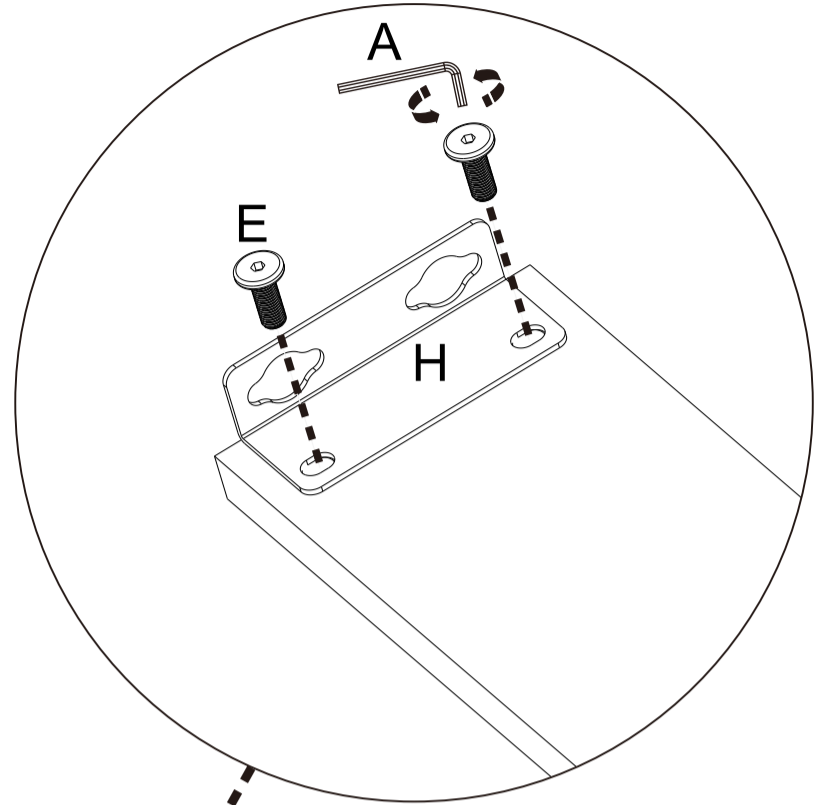

2

A x 1



E x 8



M8 x 20mm

W x 4

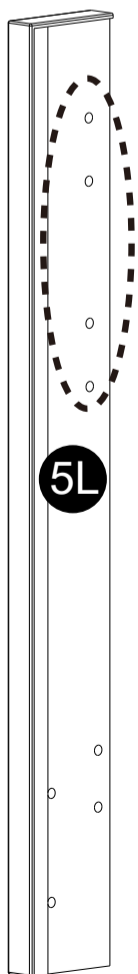

5L

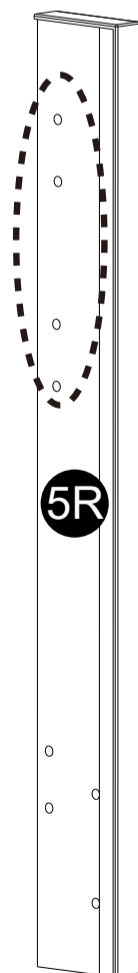

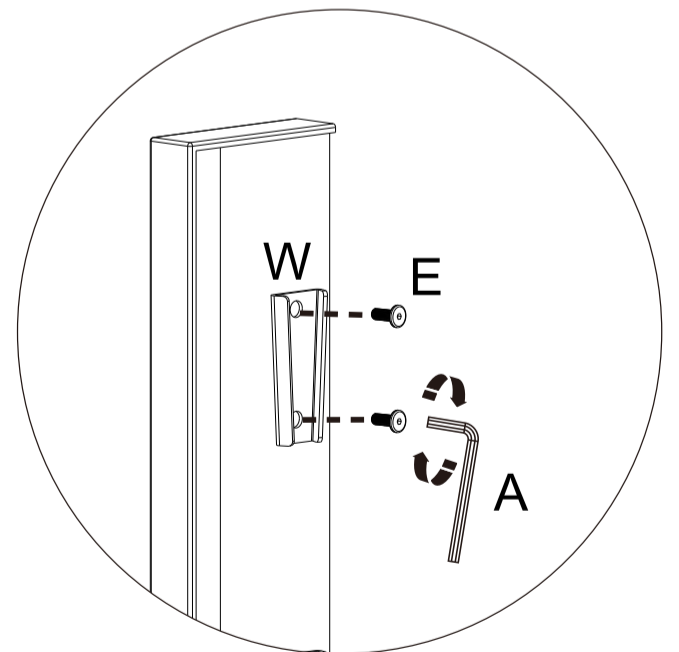

5R

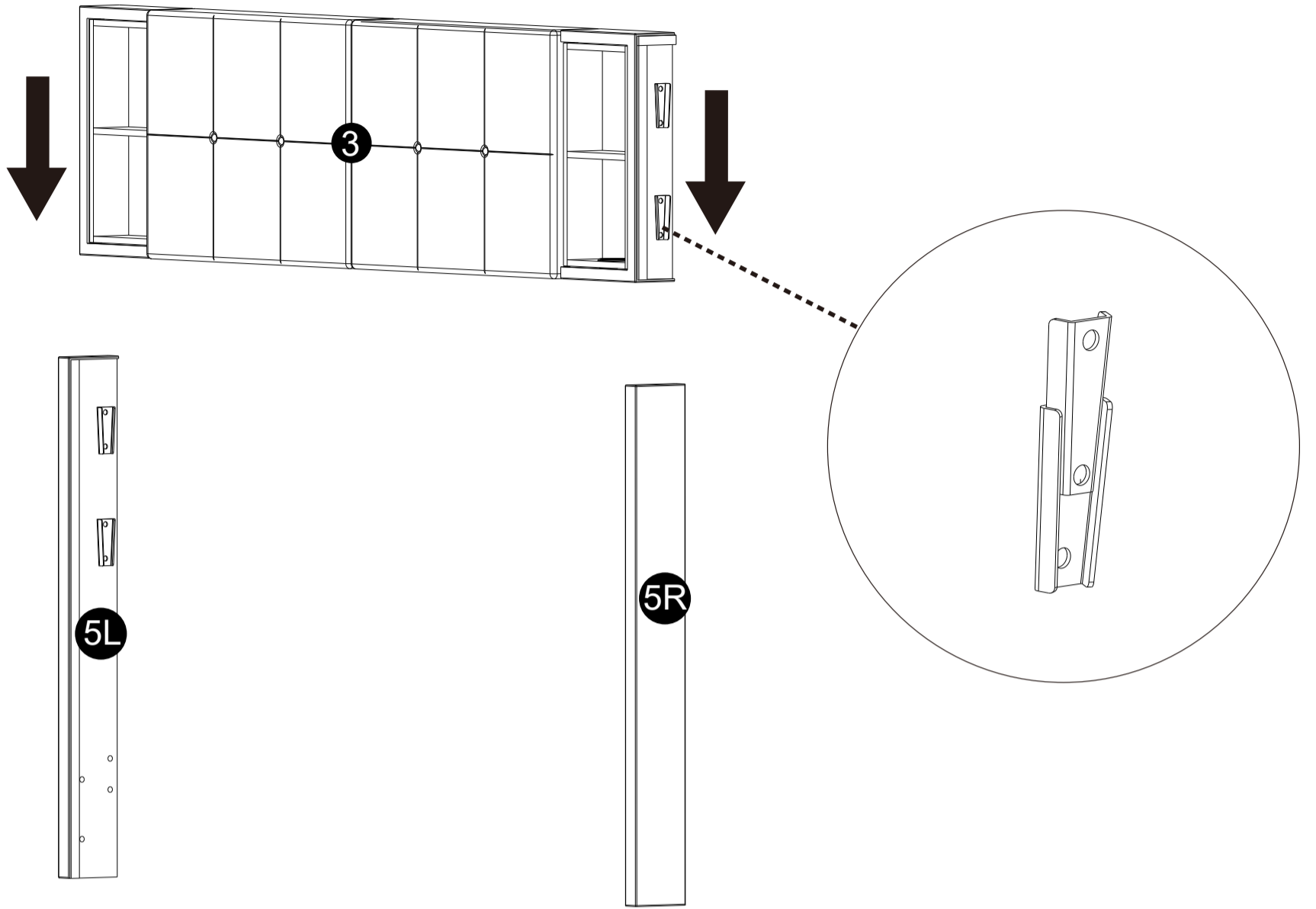

**3**



**4**

A x 1	E x 4
	
	M8 x 20mm

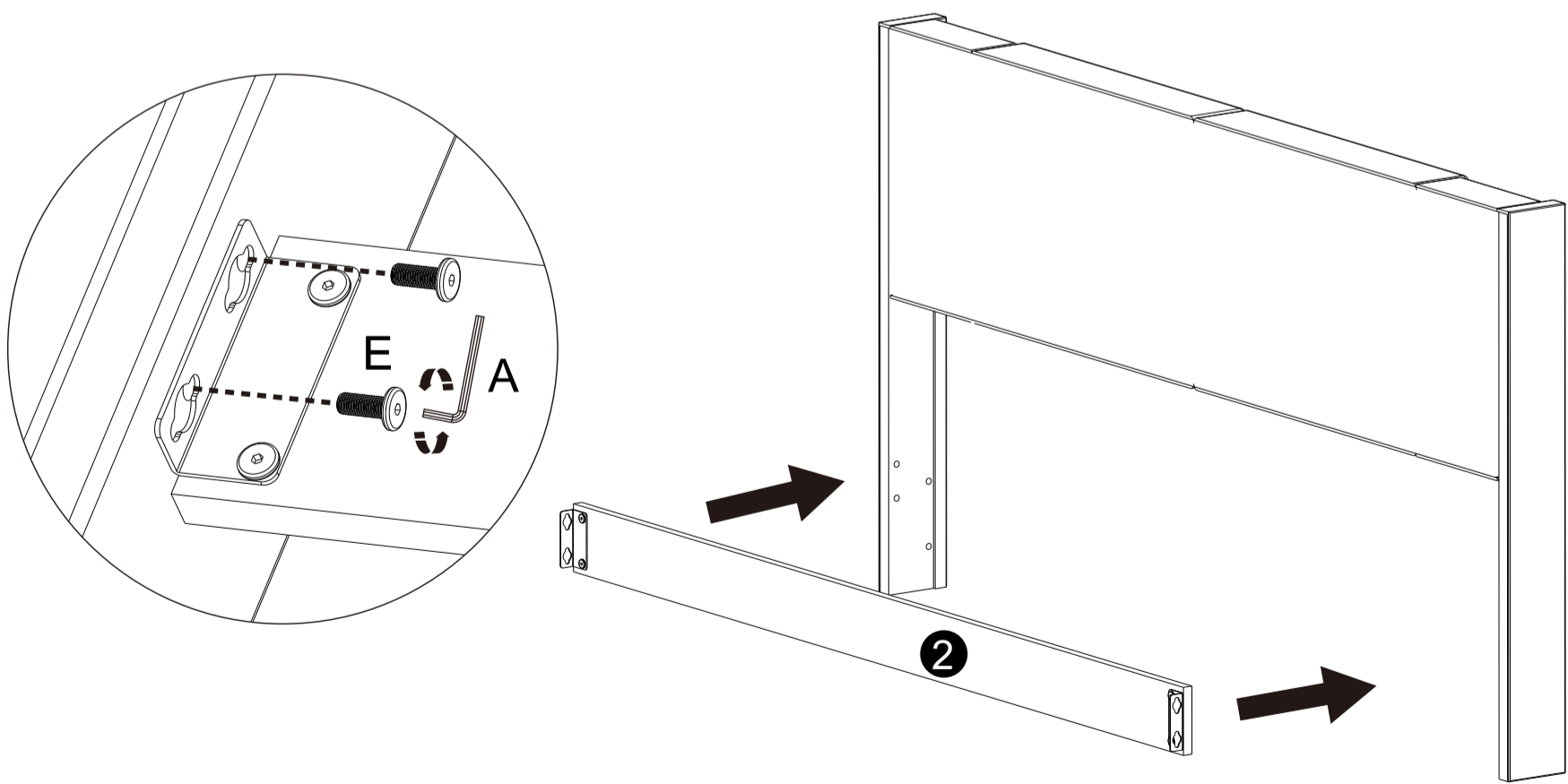

5

A x 1



B x 2



M4 x 40mm

E x 4



M8 x 20mm

K x 2



S x 2

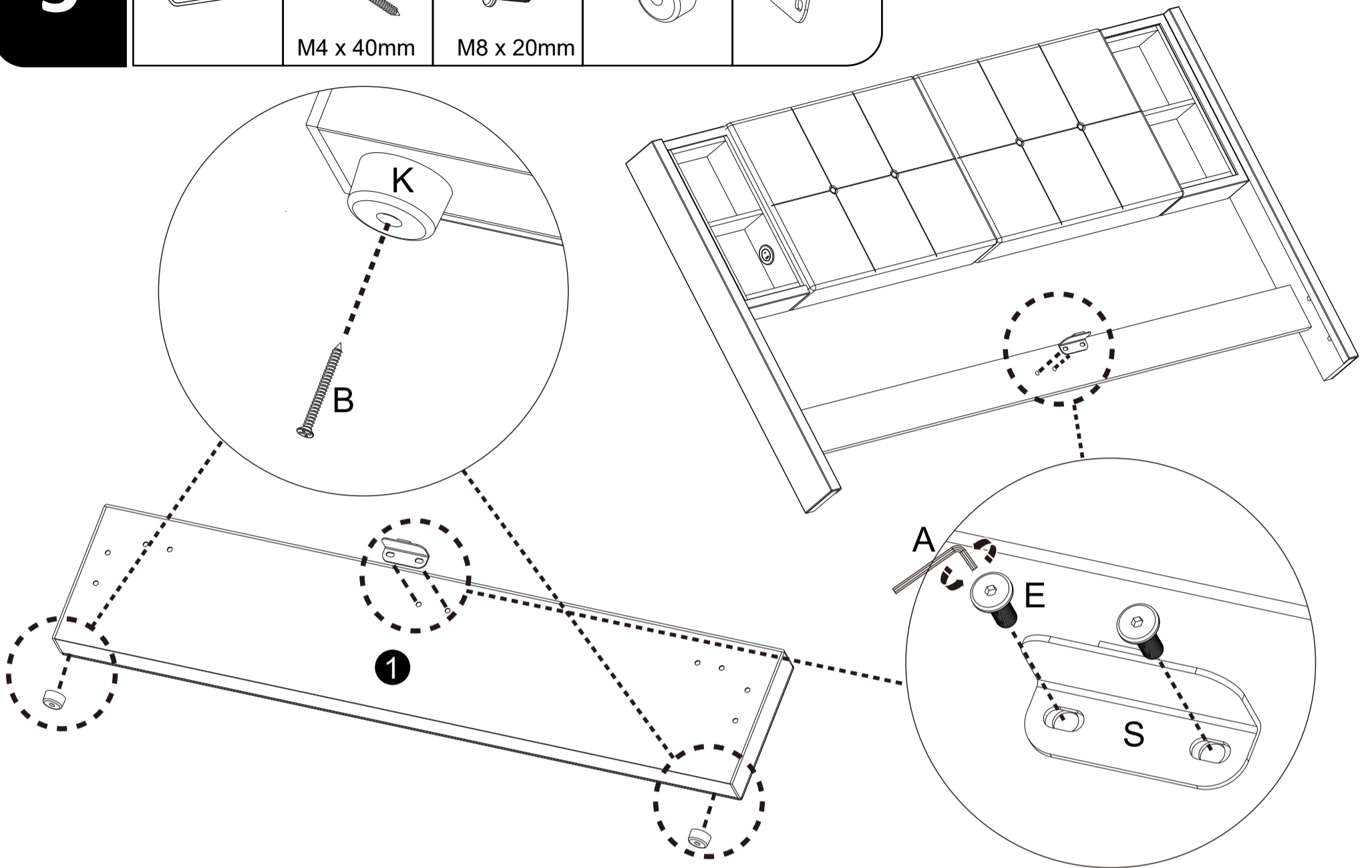
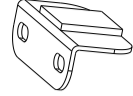

6

A x 1





E x 4



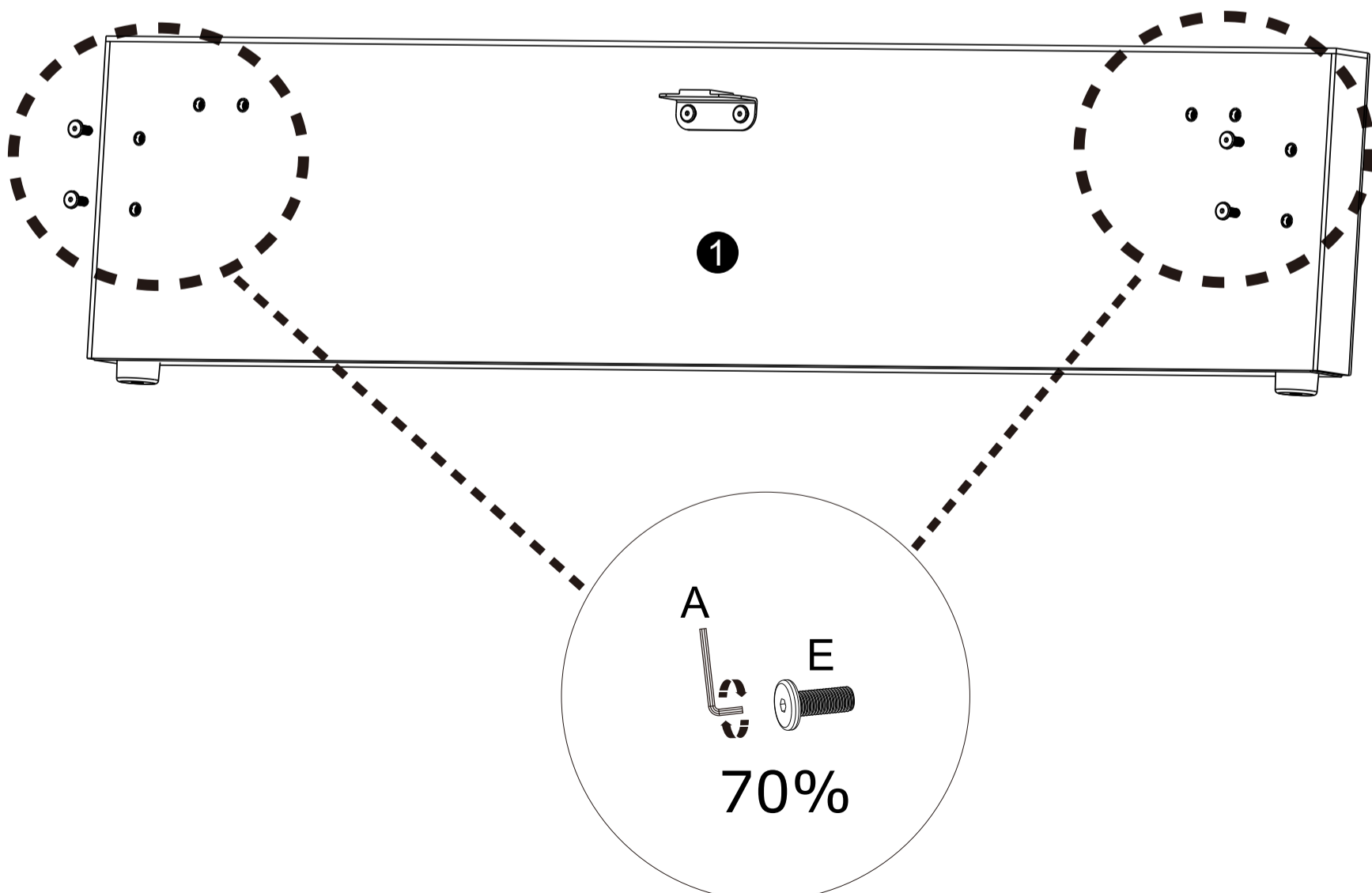

M8 x 20mm

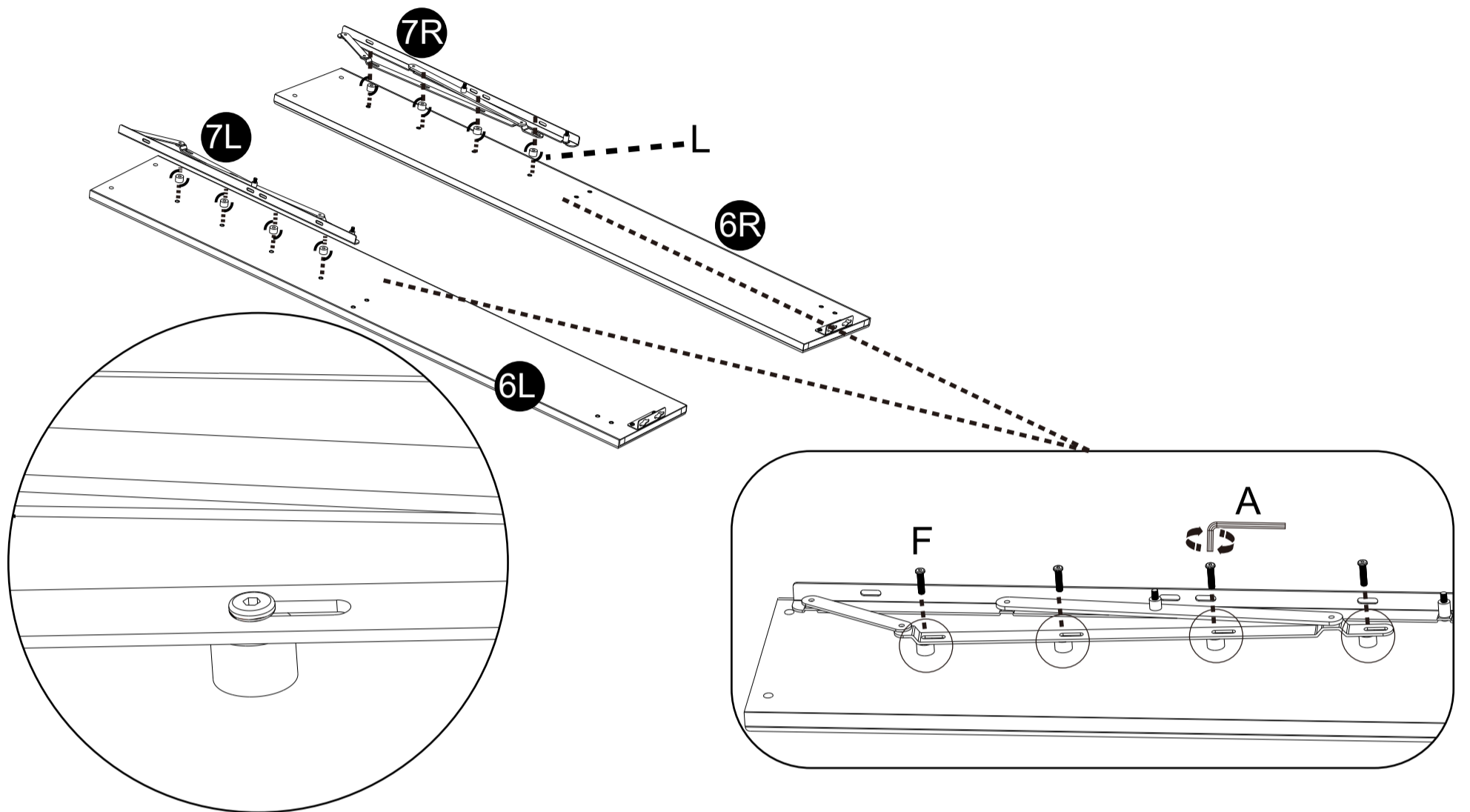

<b>7</b>	A x 1	F x 8	L x 8
		 M8 x 30mm	



<b>8</b>	A x 1	G x 4	J x 4
		 M8 x 40mm	

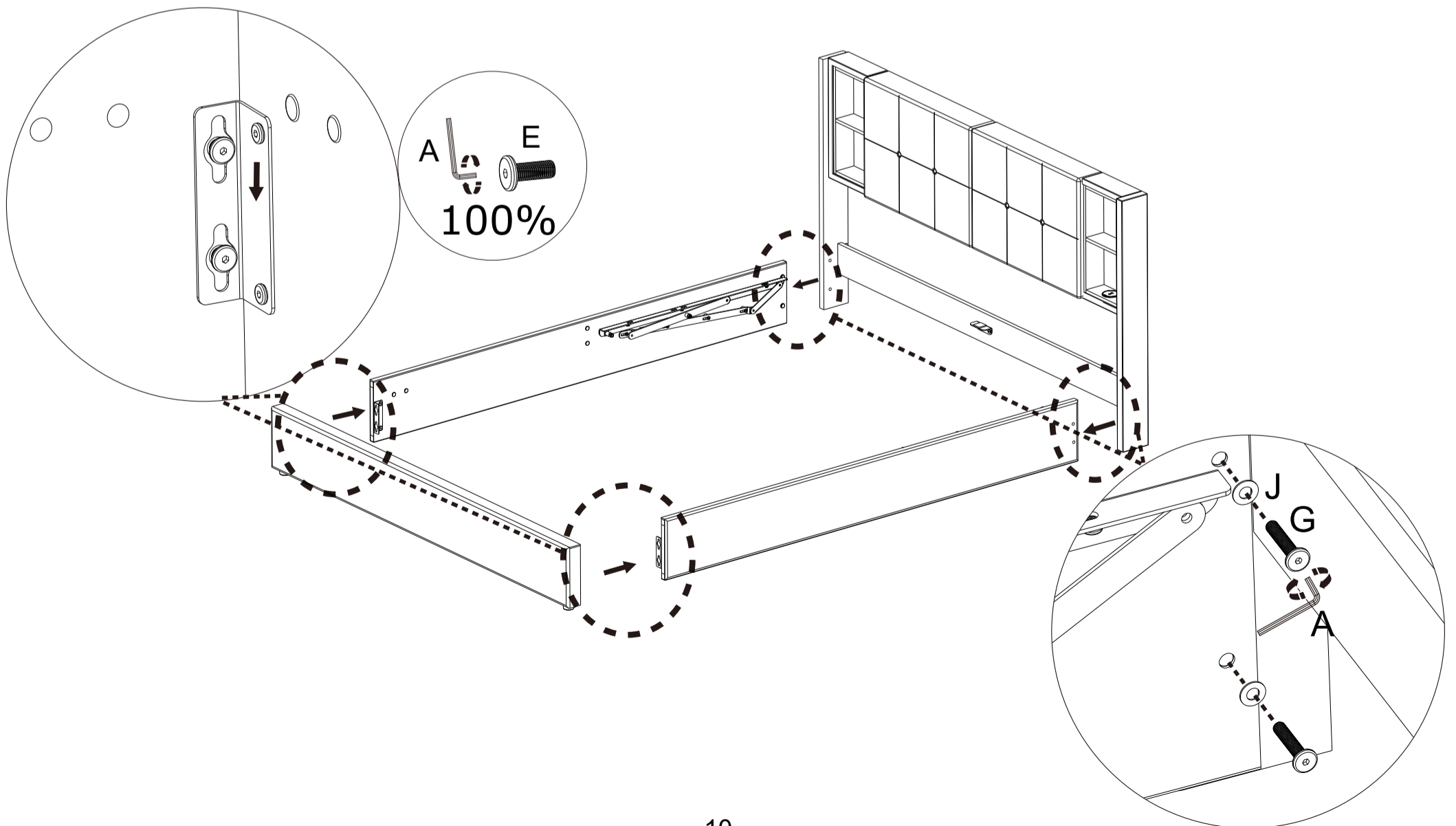

9

A x 1



E x 8



M x 2

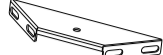

M8 x 20mm

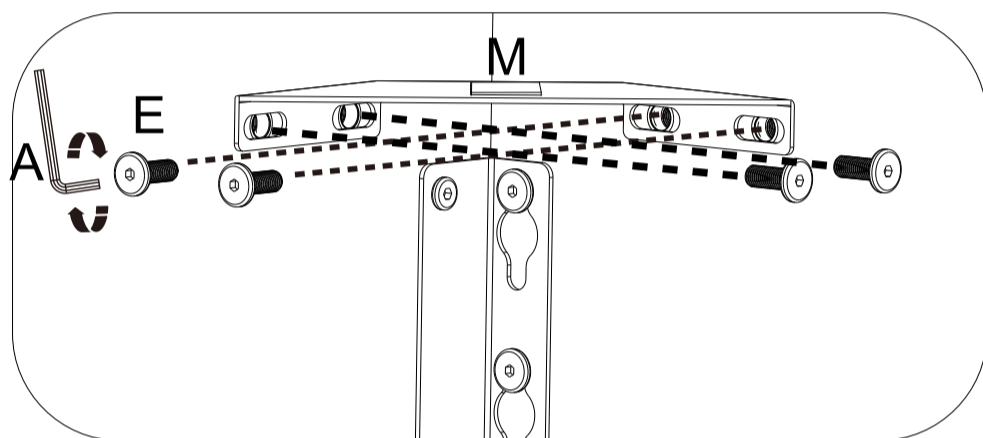
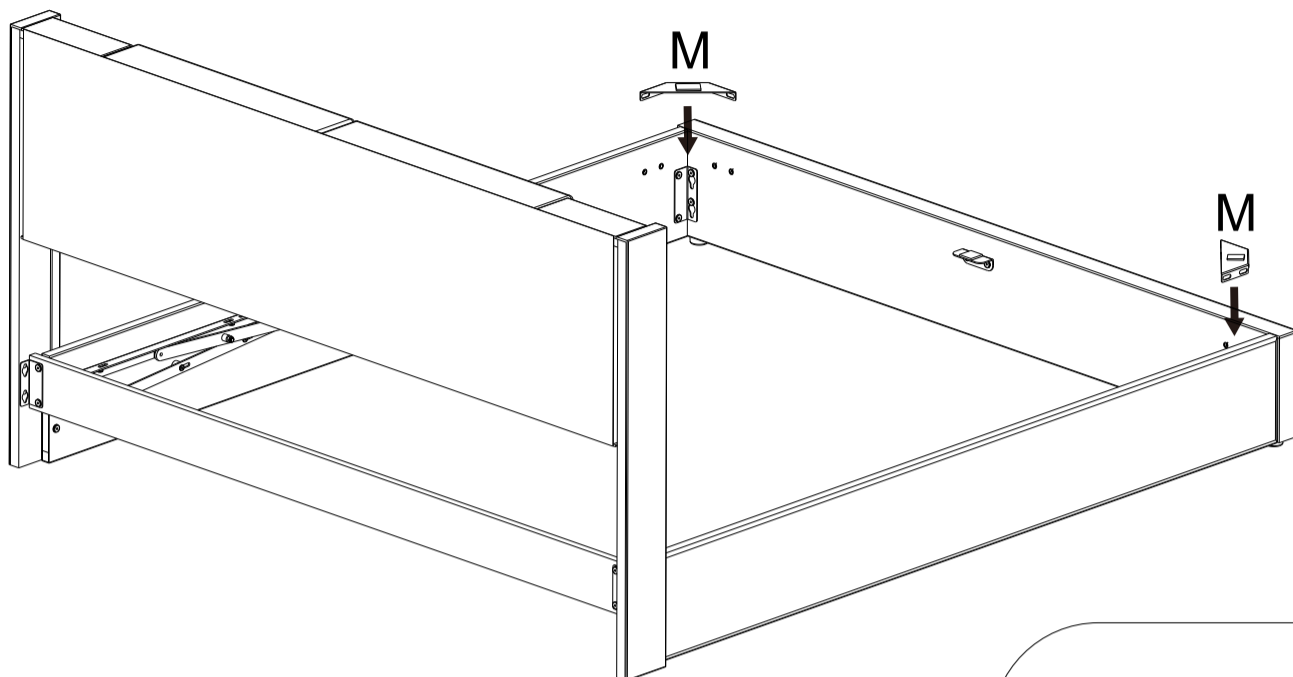

10

A x 1



D x 4



M8 x 18mm

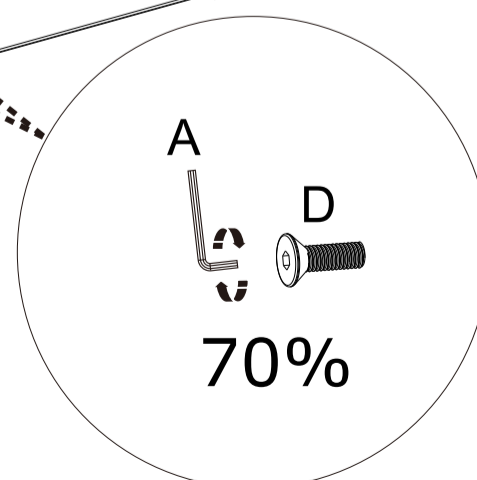
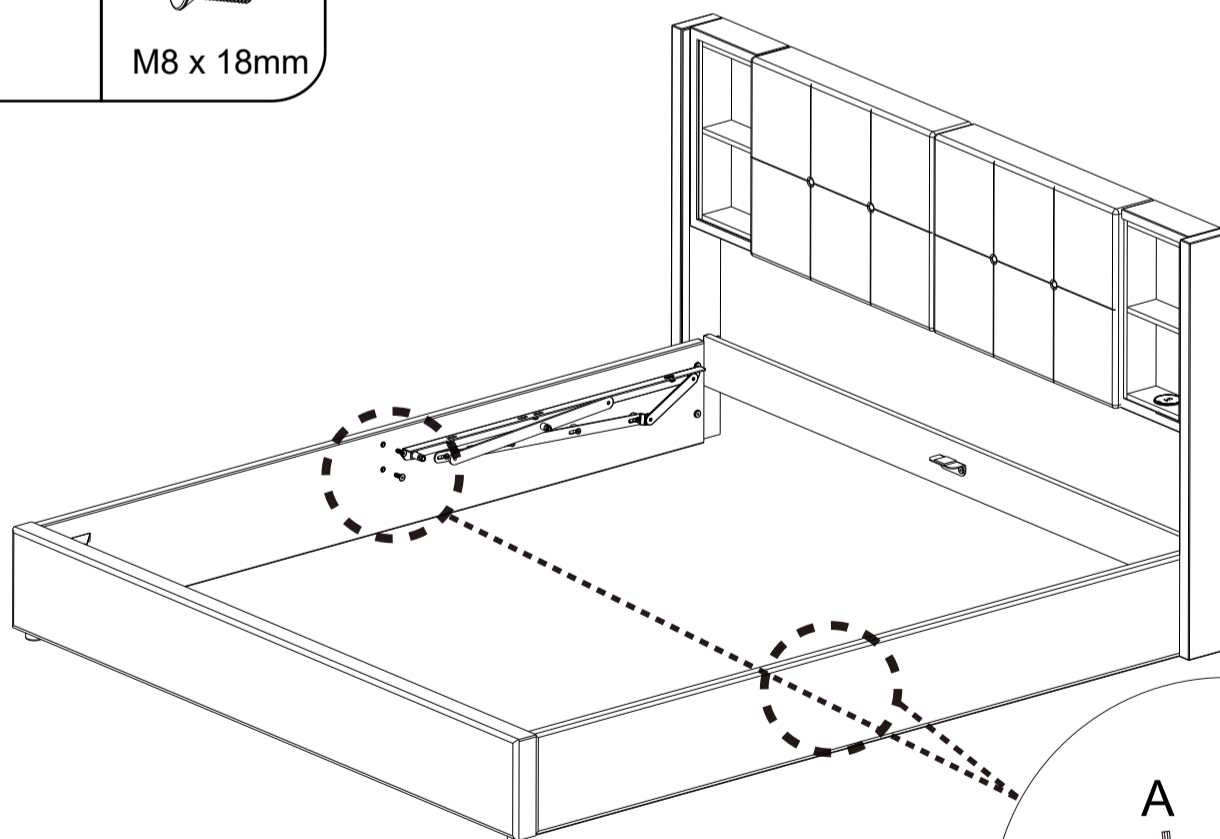

11

A x 1

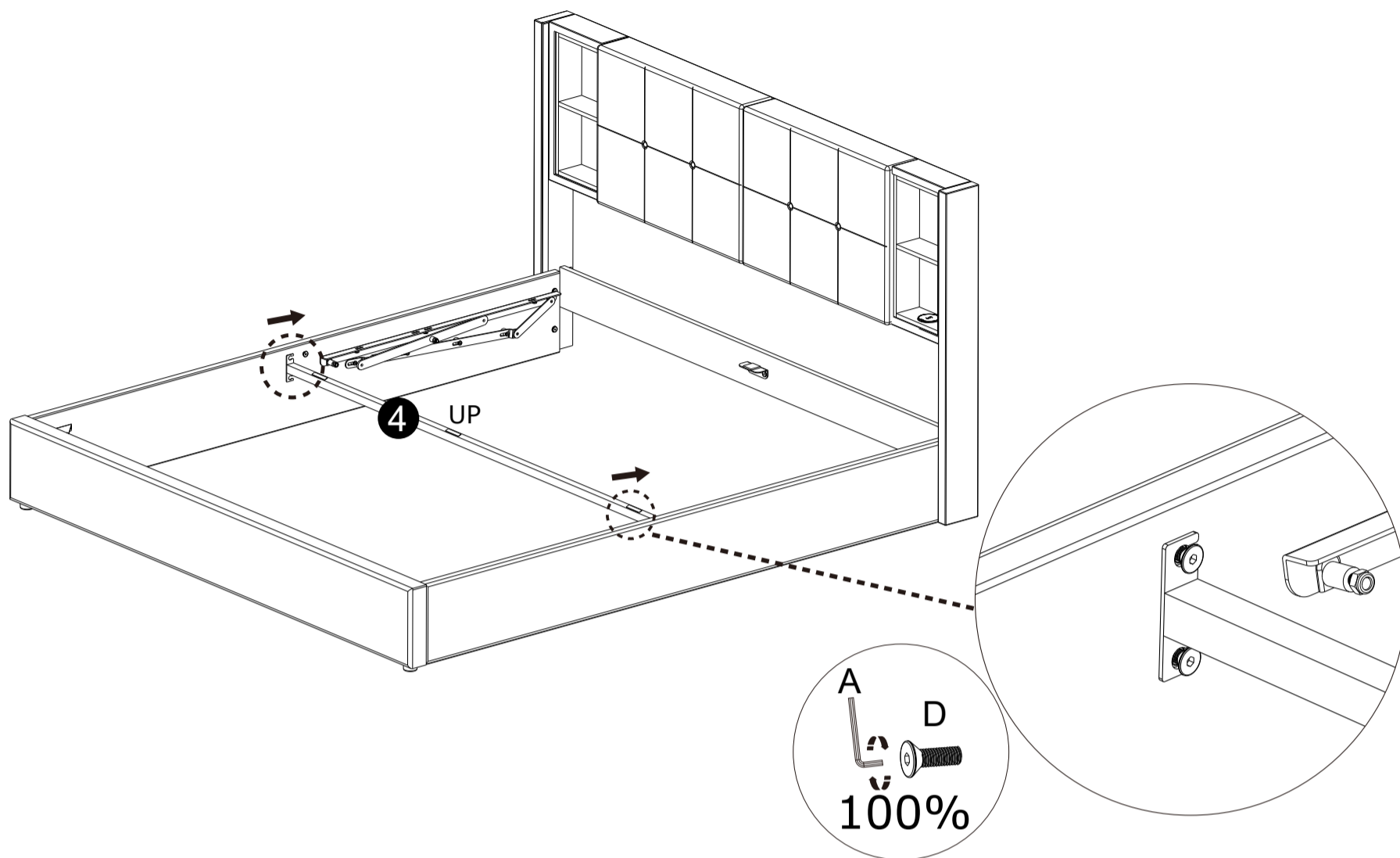

12

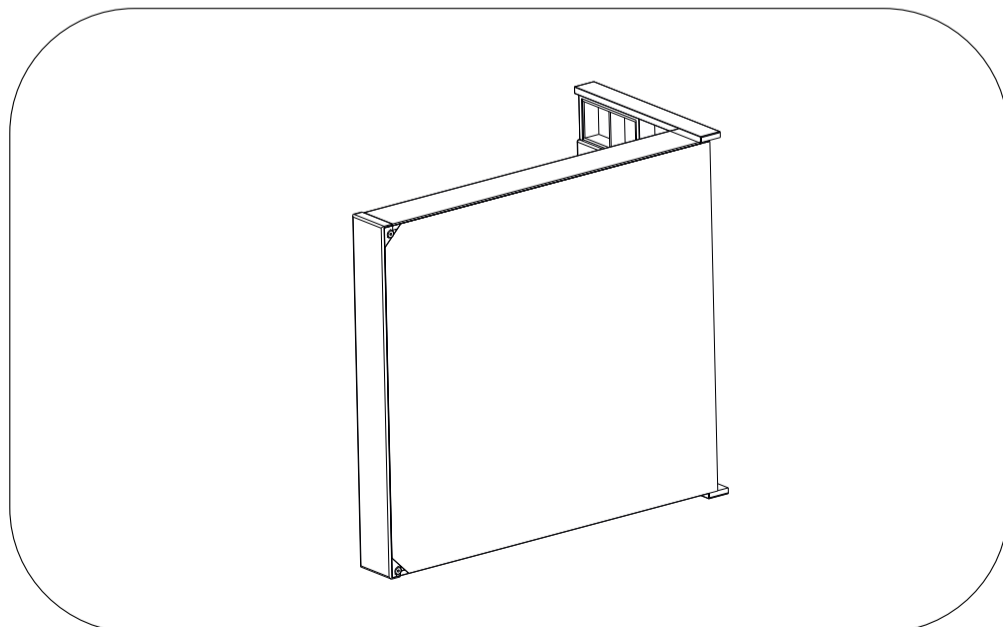
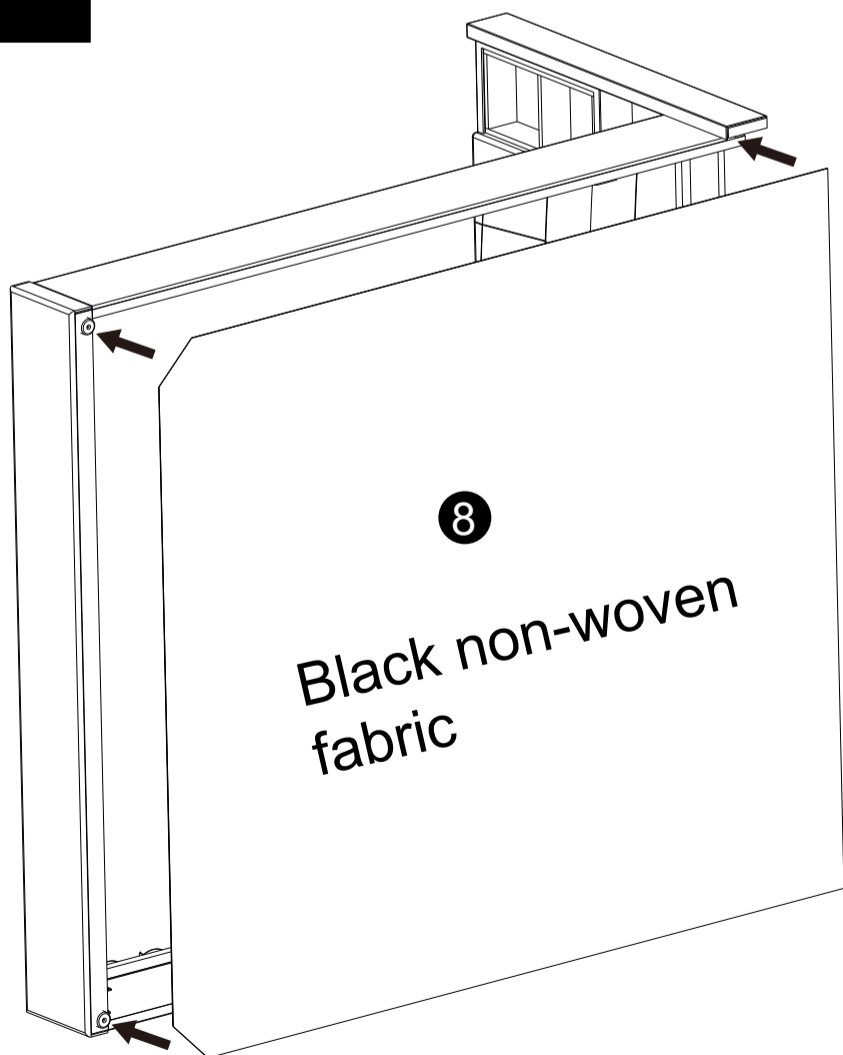

# 13

A x 1	G x 6 M8 x 40mm	J x 6	N x 6	P x 1
-------	--------------------	-------	-------	-------

!!! Please aware the orientation of the holes on #9  
!!!Bitte beachten Sie die Ausrichtung der Löcher auf #9  
!!! Attention à l'orientation des trous sur le #9

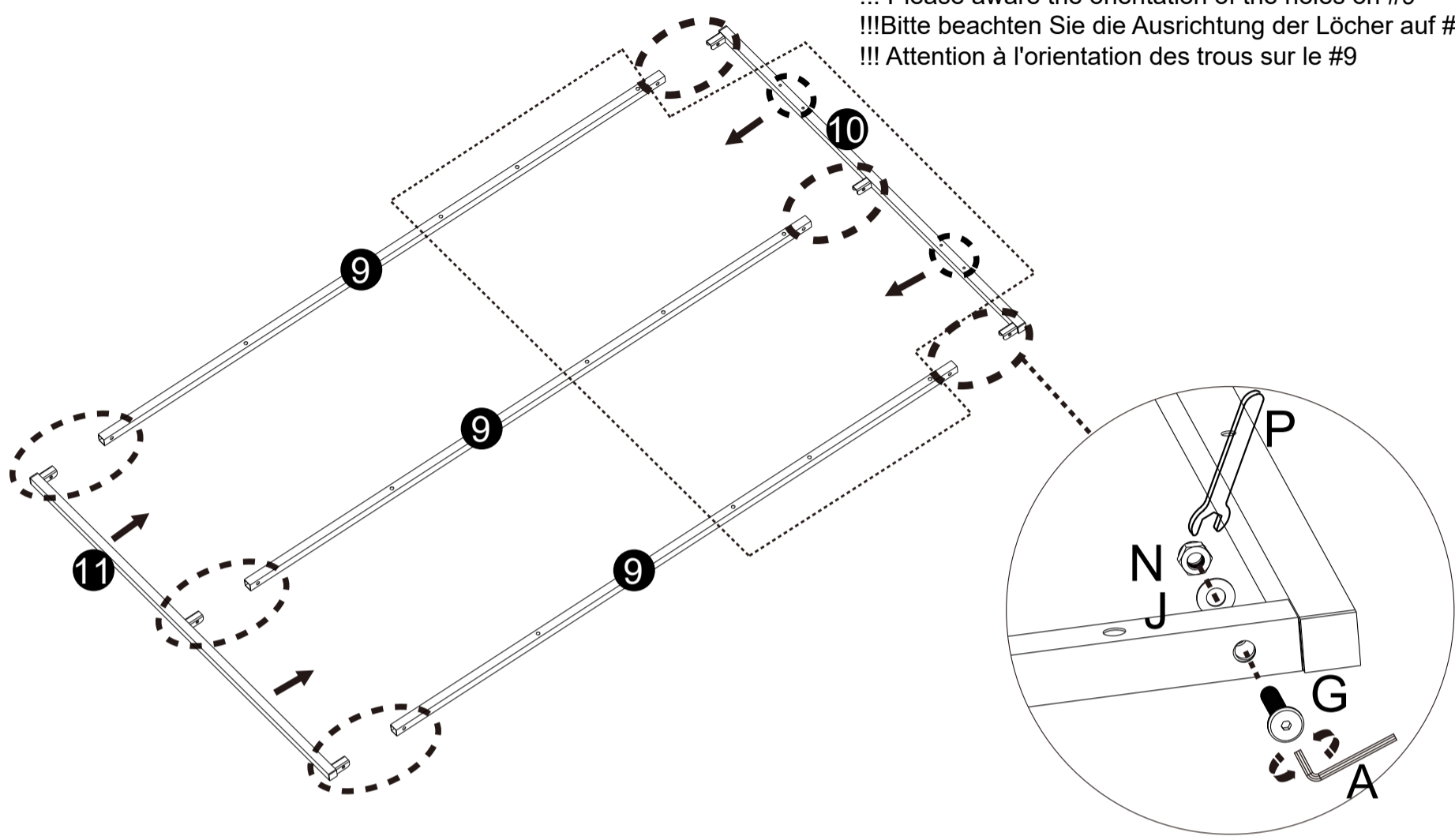

# 14

A x 1	C x 2 M6 x 35mm	J x 2
-------	--------------------	-------

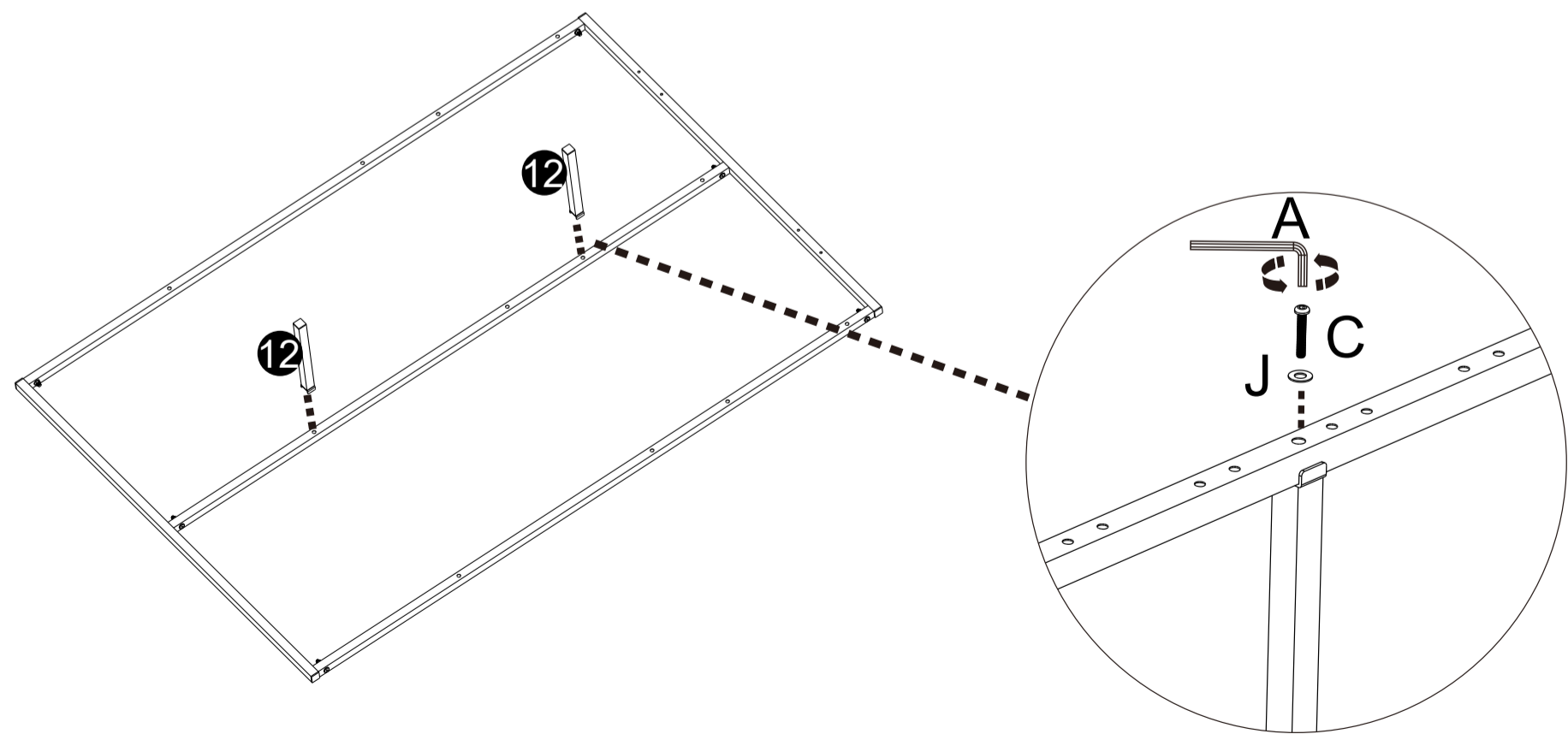

15

A x 1



G x 6



M8 x 40mm

N x 6

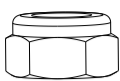

P x 1

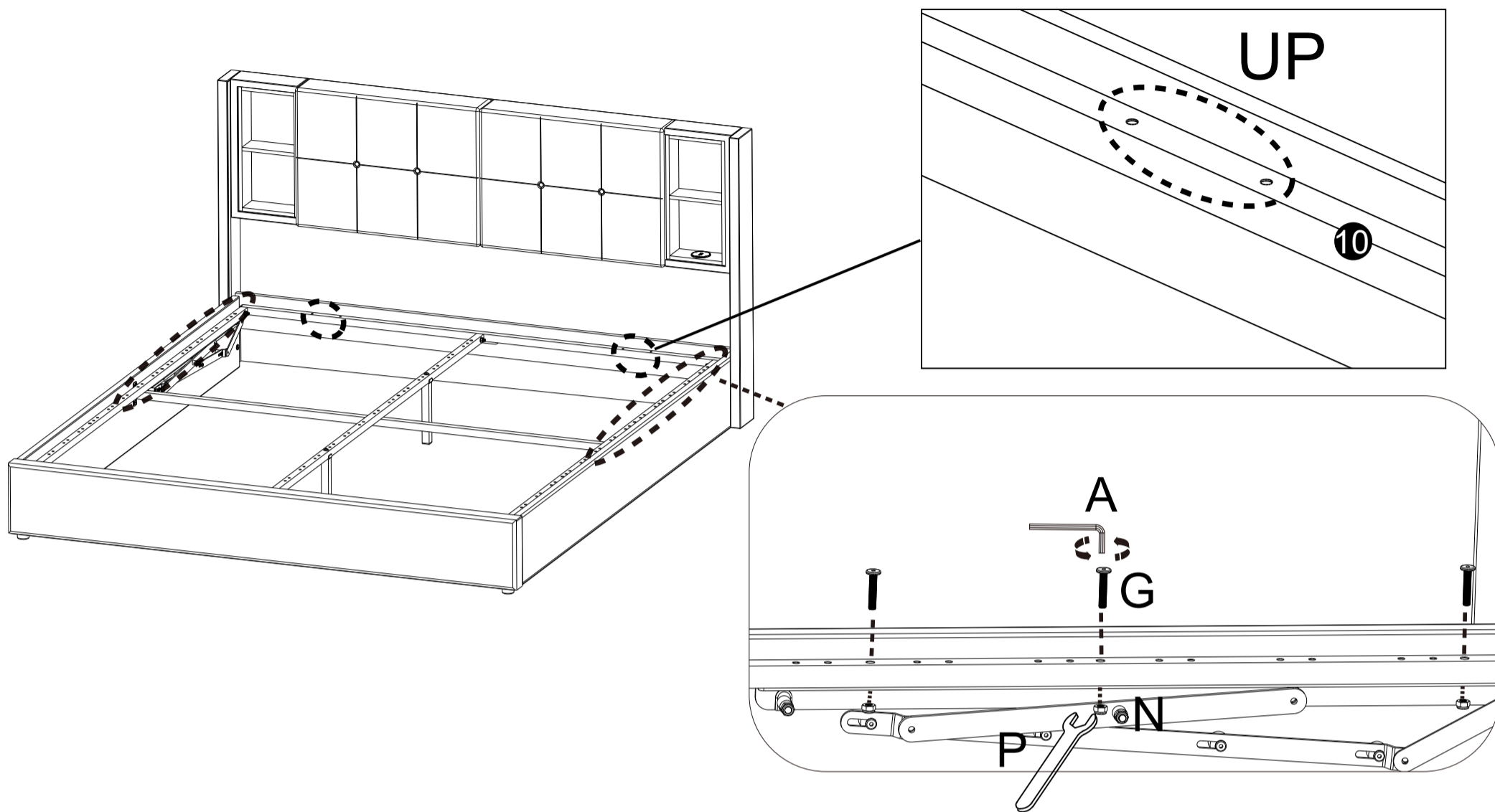

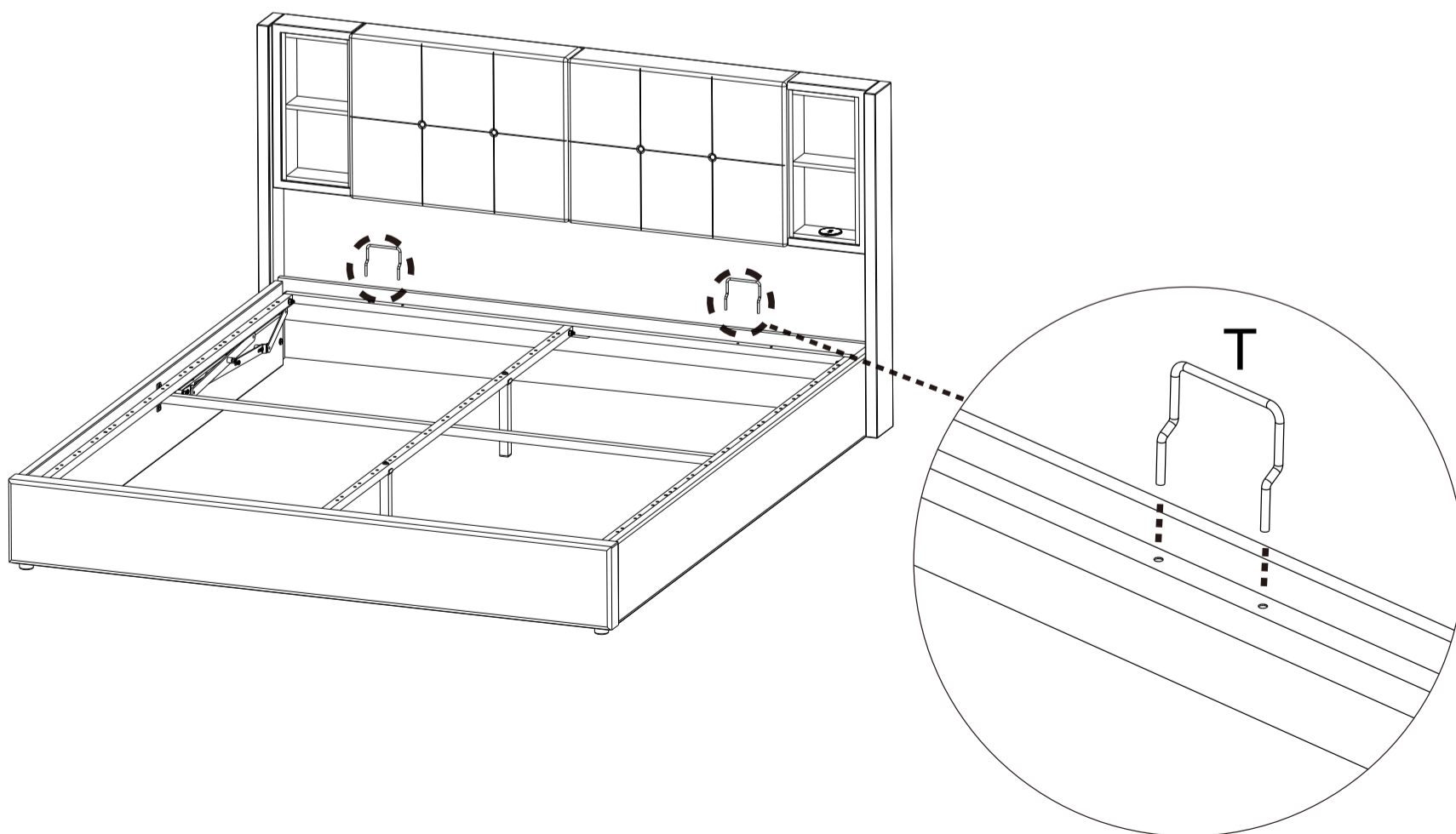
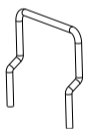

16

T x 2

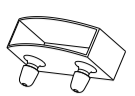
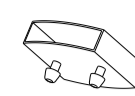

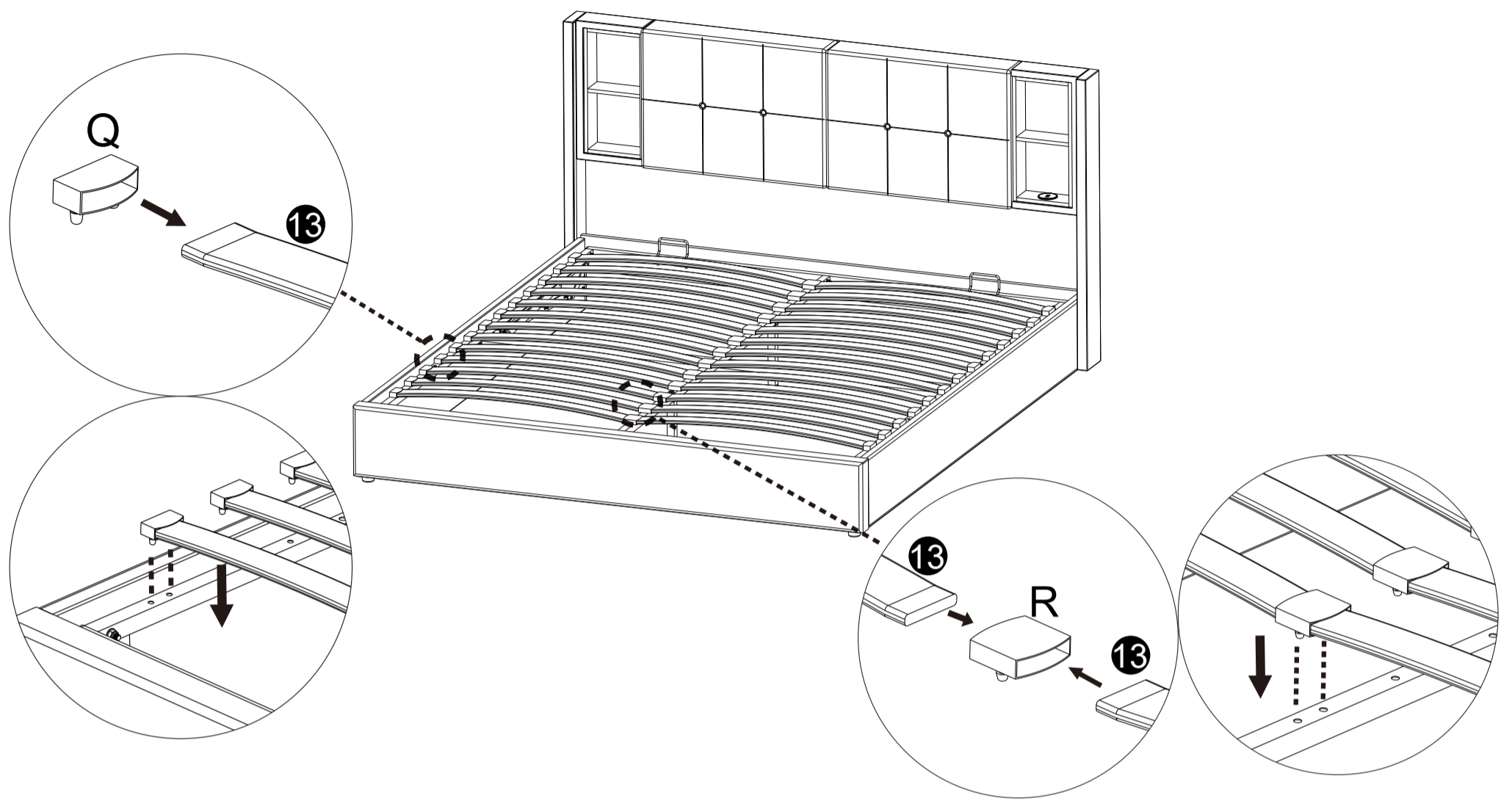
<b>17</b>	<b>Q</b>	<b>R x 13</b>
		
	135*190 x 24PCS 150*200 x 26PCS 180*200 x 26PCS	135*190 x 12PCS 150*200 x 13PCS 180*200 x 13PCS

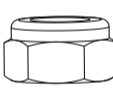

<b>18</b>	<b>N x 4</b>	<b>P x 1</b>
		

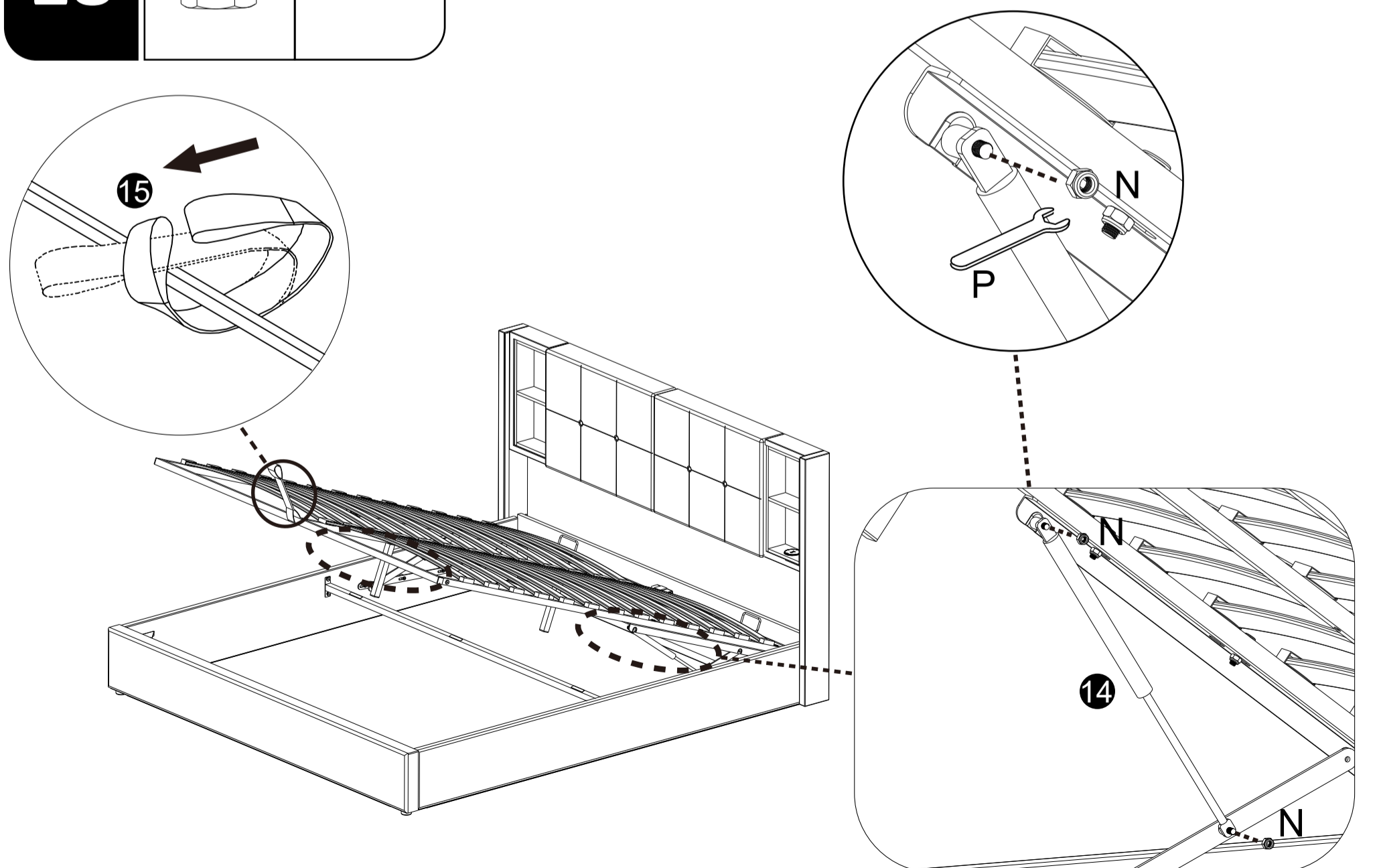

19

U x 1



V x 1

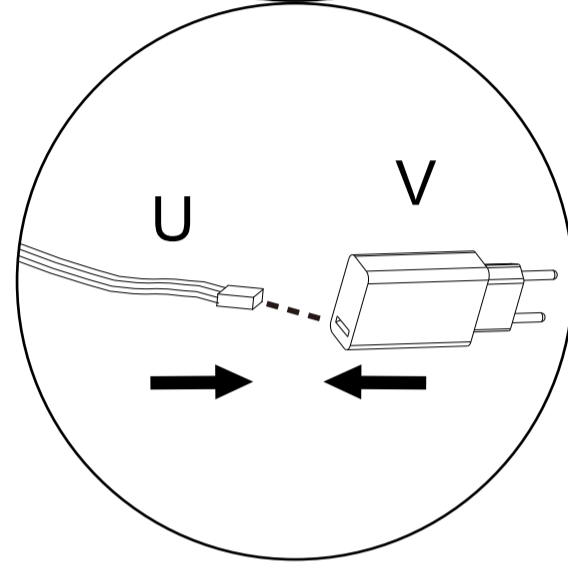
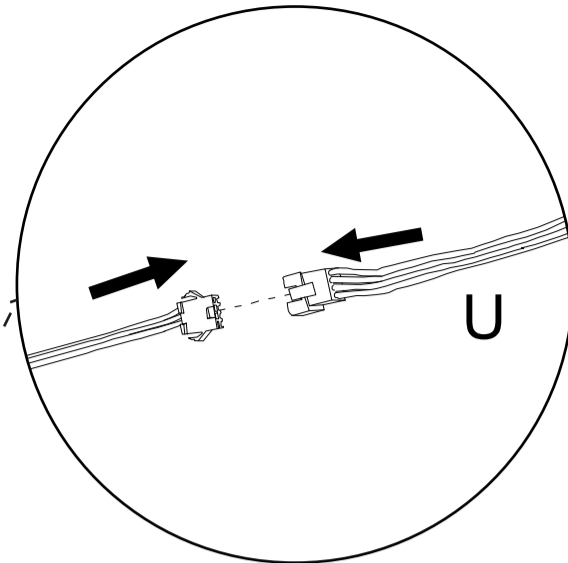
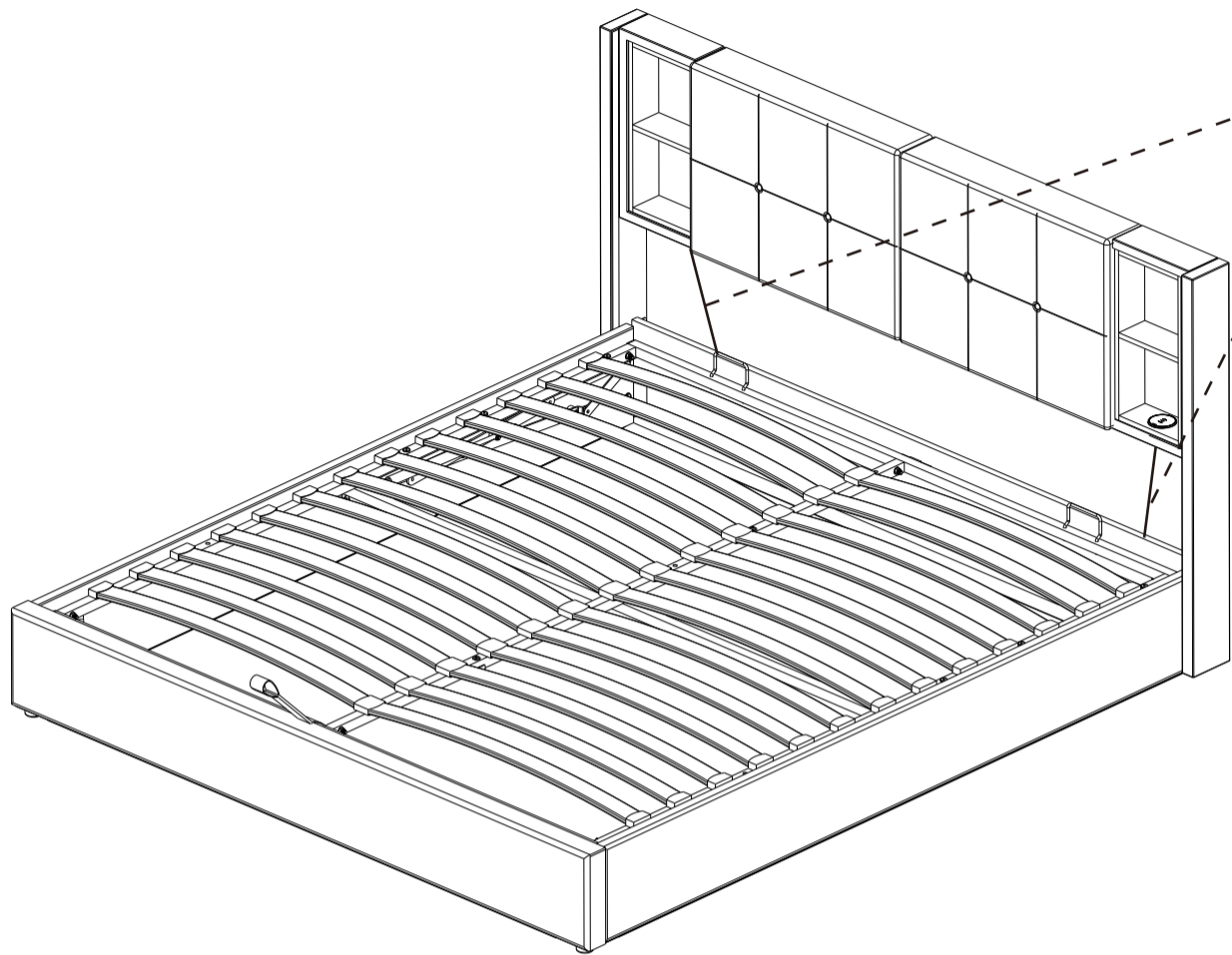

20

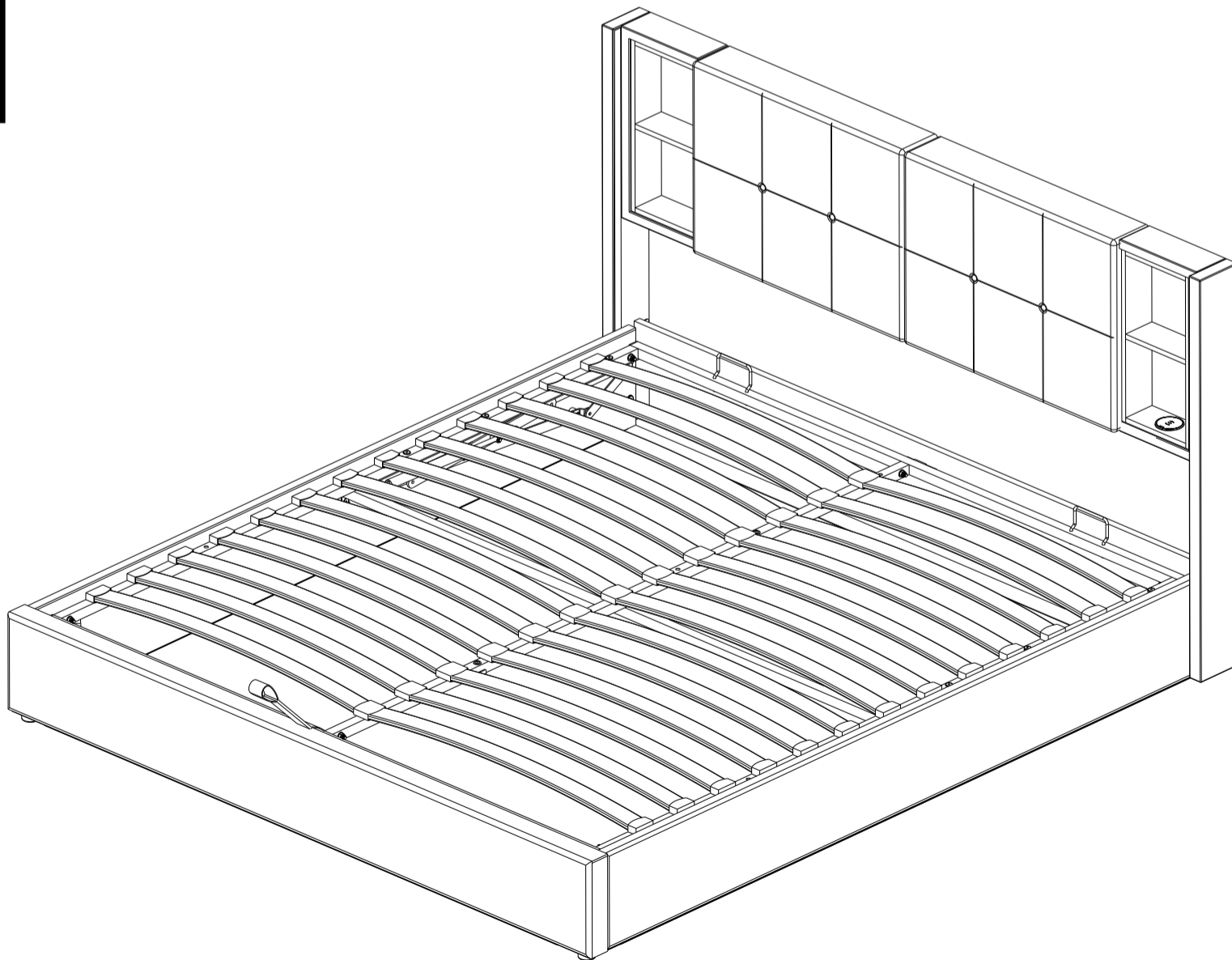

**Question: What to do if the slat frame is tilted?**

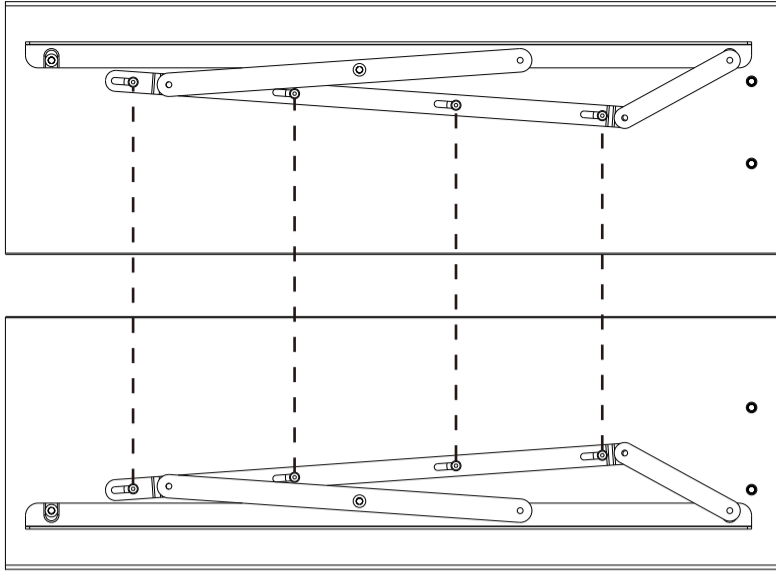

**Answer:**

The hole on the hydraulic rod is oval. Please make sure that the installation positions on the left and right sides are the same. If you accidentally install one side of the hydraulic rod in the front and the other side in the back, the slat frame will be crooked and you will need to disassemble it and reinstall it.

Das Loch an der Hydraulikstange ist oval. Bitte stellen Sie sicher, dass die Einbaupositionen auf der linken und rechten Seite gleich sind. Wenn Sie versehentlich eine Seite der Hydraulikstange vorne und die andere Seite hinten einbauen, kann dies zu Problemen führen. Der Rahmen der Hydraulikstange ist schief und Sie müssen sie zerlegen und neu installieren.

**Question: What to do if the hydraulic system fails to press down?**

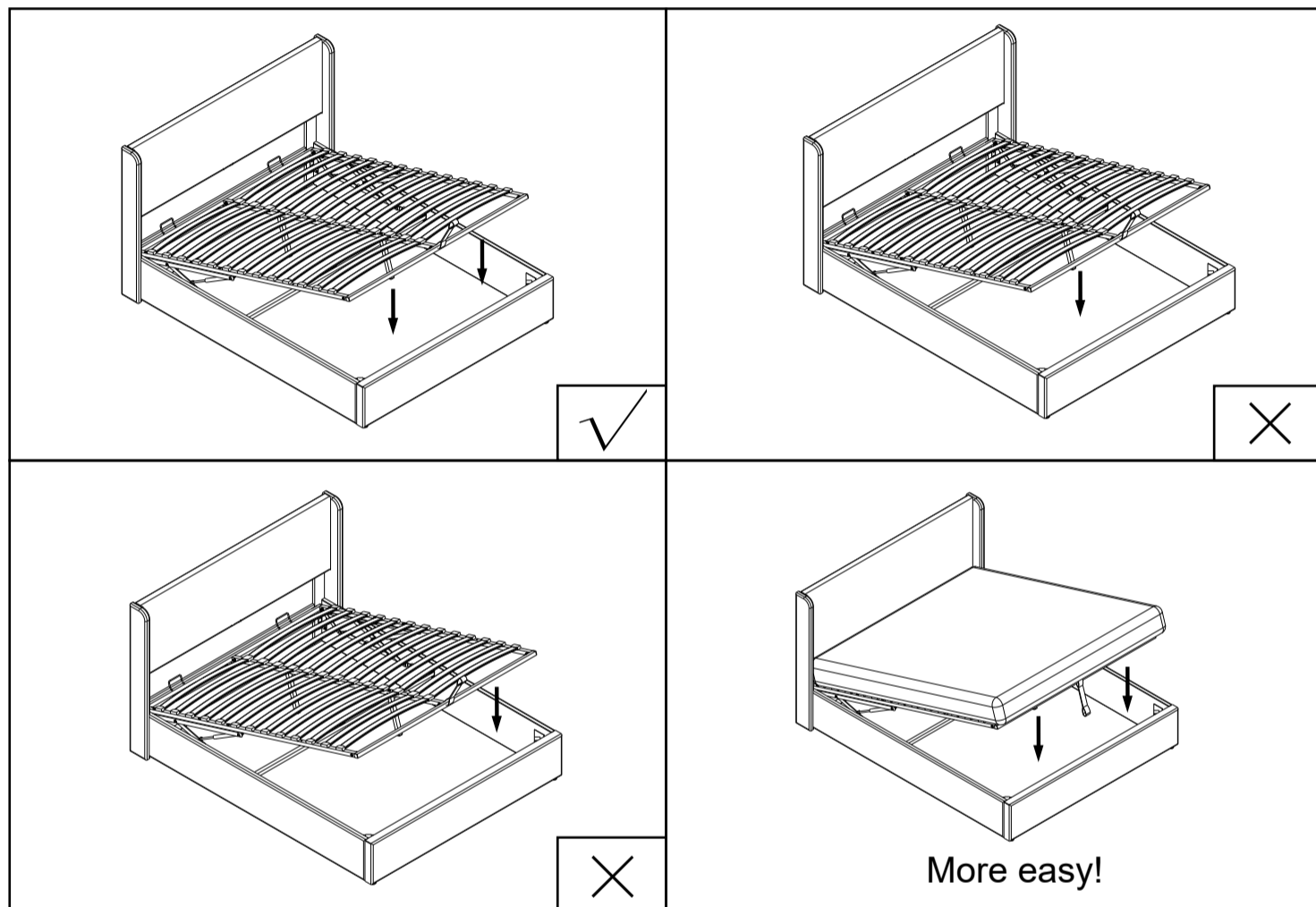

**Answer:**

When turning off the hydraulic pressure, make sure that the pressure point is at the position indicated by the arrow, Place your hand at the pressure point.

If you place the mattress on a slatted frame, it will be easier to turn off the hydraulic pressure.

Do not press only on the left side or only on the right side, as this will damage the hydraulic system.

Stellen Sie beim Abschalten des Hydraulikdrucks sicher, dass sich der Druckpunkt dort befindet, wo der Pfeil anzeigt, Legen Sie Ihre Hände auf die Druckpunkte. Wenn Sie die Matratze auf einen Lattenrost legen, lässt sich der hydraulische Druck leichter abstellen. Drücken Sie nicht nur auf die linke oder nur die rechte Seite, da dies zu Schäden am Hydrauliksystem führen kann.

If you are having trouble closing the bed frame please scan the link below which will show you how to close the bed frame properly

Mach das bettgestell nicht zu  
Bitte überprüfen sie den link, der ihnen sagt, wo er ist  
Wie schaltet man das bett richtig aus