

ASSEMBLY INSTRUCTIONS

PARTS LIST				HARDWARE LIST		
NO	DESCRIPTION		QTY	NO	DESCRIPTION	QTY
1	TOP		1	A	JCBC SCREW Ø6 x 5/32 x 45mm	16 sets
2	SIDE FRAME		2	B	Basket frame	3 pcs
3	SHELF FRAME		3	C	Basket bottom	3 pcs

STEP 1:
 A. PLACE TOP (1) ON A FLAT, PROTECTED SURFACE. B. ATTACH SIDE FRAME (2) TO TOP (1) WITH BOLTS (A). C. USING SCREW DRIVER (NOT PROVIDED). LOOSELY TIGHTEN.

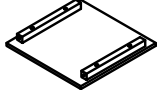
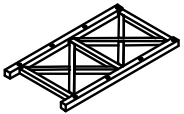
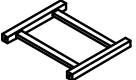
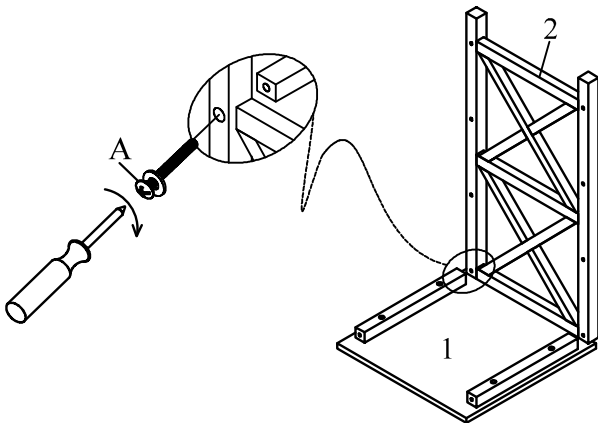

STEP 2:
 A. ATTACH THE OTHER SIDE FRAME (2) TO TOP (1) WITH BOLTS (A). B. C. USING SCREW DRIVER (NOT PROVIDED). LOOSELY TIGHTEN.

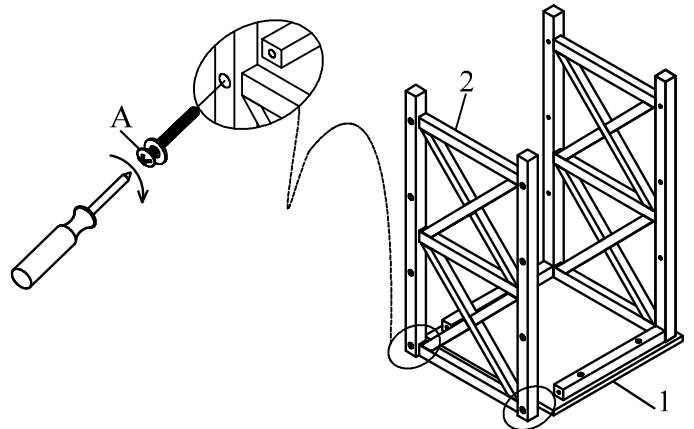

STEP 3:
 A. ATTACH SHELF FRAMES (3) WITH BOLTS (A). B. USING SCREW DRIVER (NOT PROVIDED). C. TIGHTEN ALL BOLTS AND SCREWS.

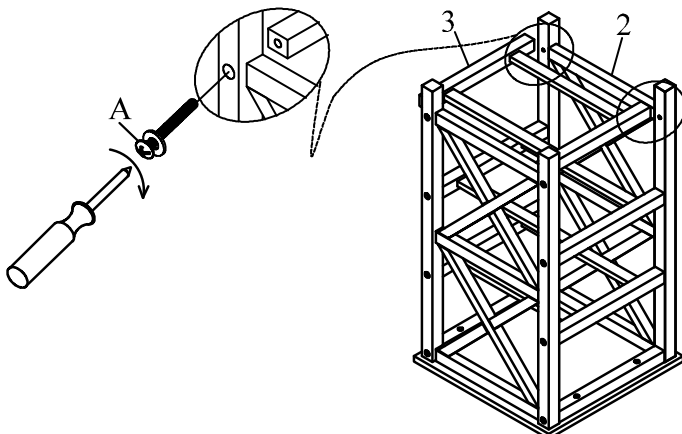

STEP 4:
 A. ROTATE THE ASSEMBLED UNIT TO UPRIGHT POSITION. B. INSERT BASKET BOTTOM (C) INTO BASKET FRAME (B). REPEAT FOR REMAINING BASKETS. C. PLACE THE BASKETS INTO TOWER AS SHOWN.

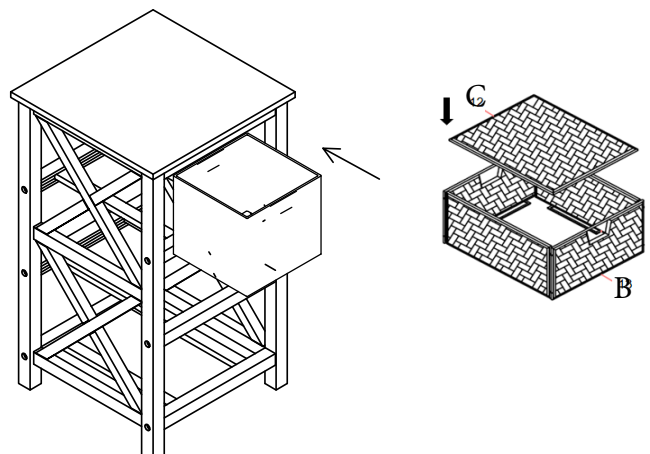

ASSEMBLY INSTRUCTIONS

STEP 5:

A. ASSEMBLY IS COMPLETE.

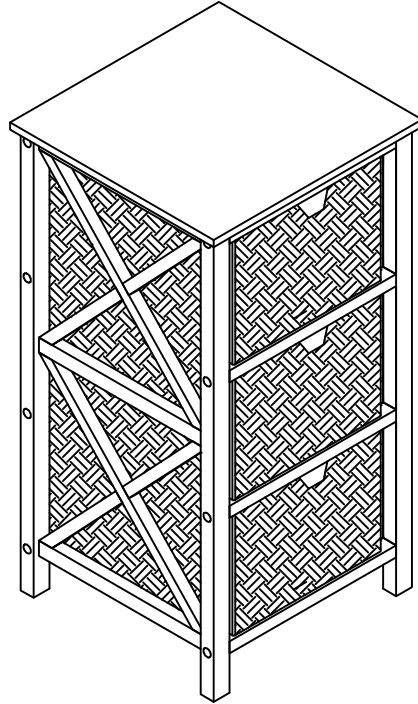

IMPORTANT NOTE:

- PLACE ALL WOODEN PARTS ON A CLEAN AND SMOOTH SURFACE TO AVOID SCRATCHING.
 - KINDLY FOLLOW THE ASSEMBLY INSTRUCTION STEP BY STEP.
 - WE RECOMMEND THAT YOU PERIODICALLY TIGHTEN ALL BOLTS/SCREWS. PLEASE MAKE SURE ALL BOLTS/ SCREWS ARE PLACED IN THEIR PROPER POSITION AND ARE TIGHTENED SECURELY TO ENSURE YOUR SAFETY.
 - WEIGHT RESTRICTION: 25 LBS.
 - DO NOT STAND OR CLIMB ON THE TOWER.
- NOT FOR COMMERCIAL USE.