

# Assembly Instructions

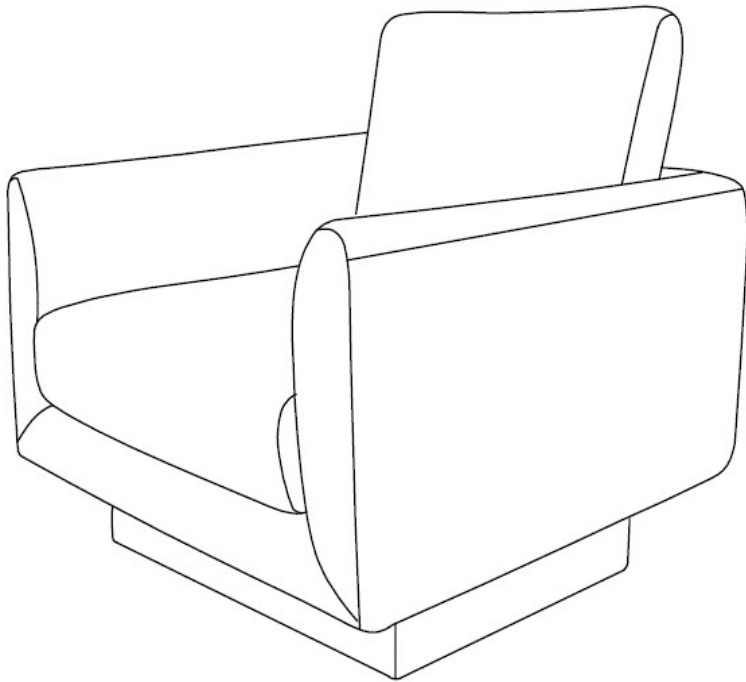

## [Guarantee]

## [ Installation Video]

Questions, Missing parts, Assembly help?

No need to return the product.

Email us Or WHATSAPP us:

[service@foresthomes-us.com](mailto:service@foresthomes-us.com)

we will reply you in 12hour.

Have a great shopping experience.

The installation video, our type transform and head adjustment on YOUTUBE for your reference.

The Youtube code is

**uTb\_JJ6CRreE**

you just search the code on YOUTUBE, the video will be there. Scan it.



WHATSAPP CODE

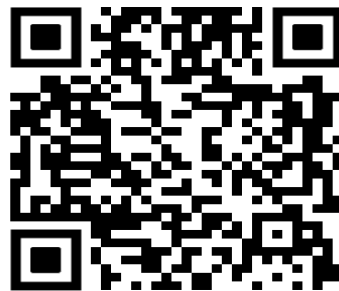

INSTALLATION VIDEO CODE

# PRE-ASSEMBLY INFORMATION

Please read this manual carefully before beginning assembly of this product.  
Keep this manual for future reference.

## NOTICE

1. Please assemble it AFTER all boxes are received.
2. Please do not throw away any of the packages or the instruction until the sofa is fully assembled.
3. Please keep children away from the plastic bags or any small pieces of stuff.
4. Some key parts of our product may be stored and hidden inside of other parts. Please open any zippered or hook & loop storage compartments to take out all parts.
5. Please do not open the compressed packages until your sofa frame is completely assembled.
6. As the cushions are all vacuum compressed, there will be some wrinkles. Please give them up to 72 hours to reach its original size and the wrinkles will basically disappear.
7. DO NOT INSTALL THE SCREWS ALL THE WAY IN THE BEGINNING. Place each screw into their proper hole and use your hand to twist the screw halfway. Twist all the screws in halfway to ensure the holes will match up properly and the product is level on the ground. When everything seems fitted, then tighten the screws.
8. Do not over tighten screws and bolts to avoid stripping.



**2 adults recommended**







**Takes about 1.5 Hours to assemble**

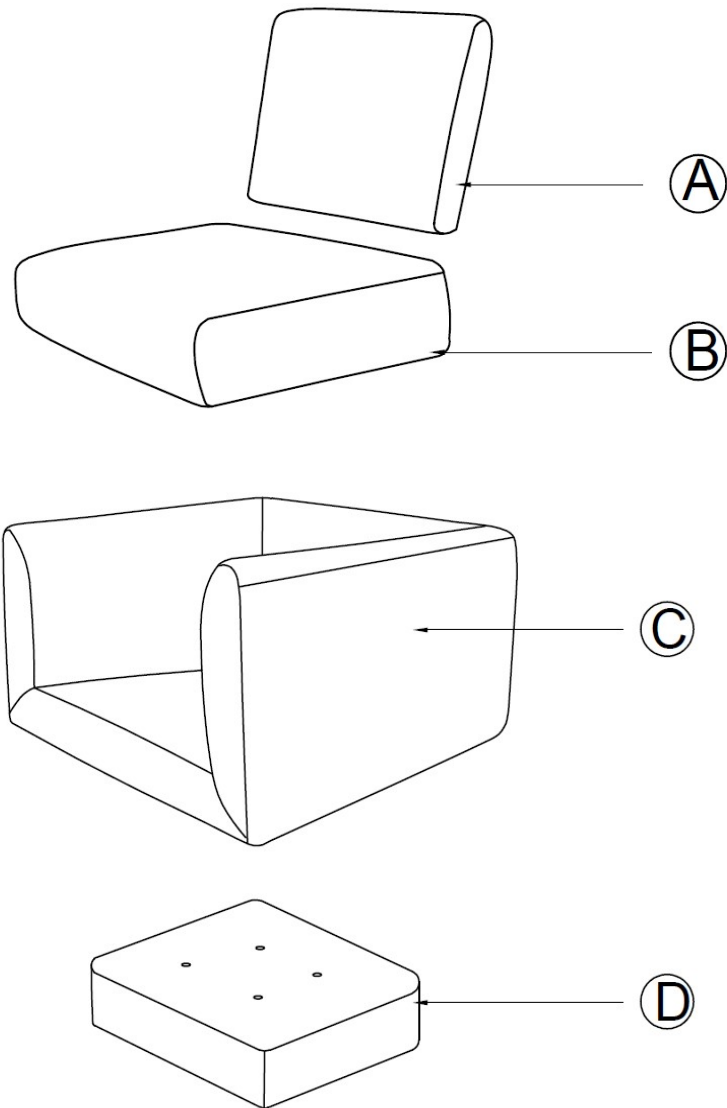

**Weight capacity of each seat: 330LBS**

# COMPONENTS



HARDWARE			
NO	DESCRIPTION	SKETCH	QTY
①	Screws M8*65		5
②	Nut		5
③	Washer		5
④	Wrench		2

# COMPONENTS

**(A) Back Cushion**

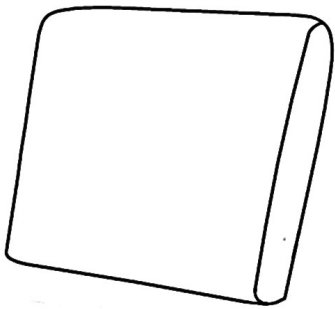

**1PC**

**(B) Seat Cushion**

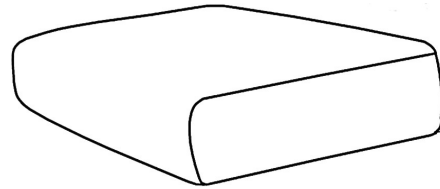

**1PC**

**(C) Chair Seat**

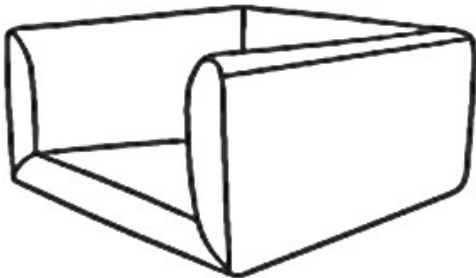

**1PC**

**(D) Leg Base**

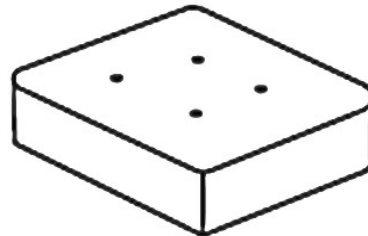

**1PC**

# ASSEMBLY STEPS

**STEP1** Install the leg base(D) to chair seat(c) using screws(①) ,nut(②) ,washer(③) with wrench(④).

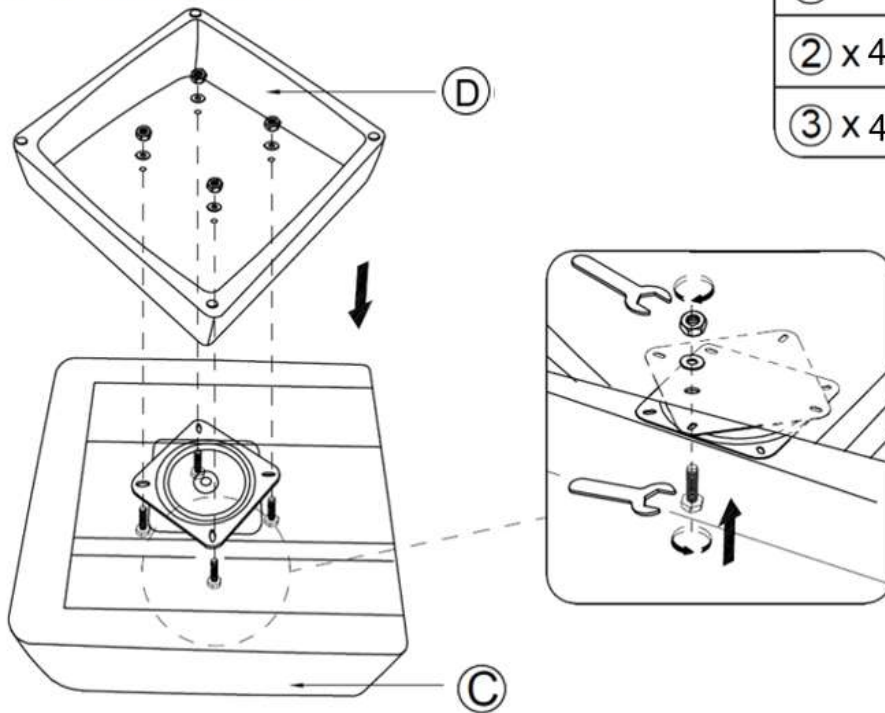

**STEP2** Put the seat cushion(B) and back cushion(A) on the chair.  
Then your chair is ready for use.

