

Installation & Assembly

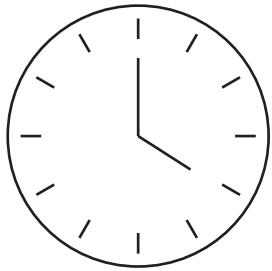

Temps d'assemblage
60 minutes
Assembly time

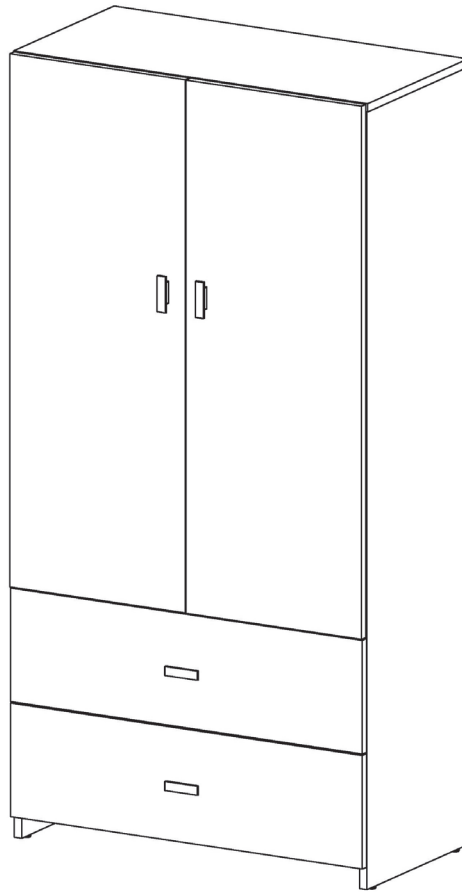

Numéro de série
Serial Number

Outillage requis
Required tools

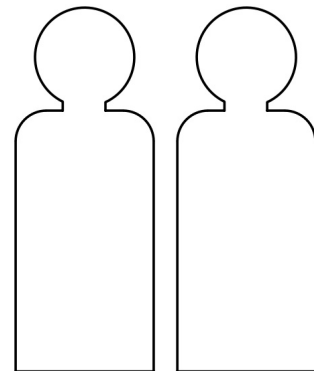
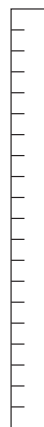
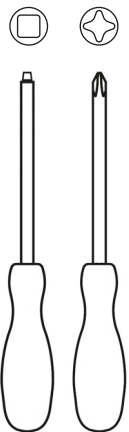
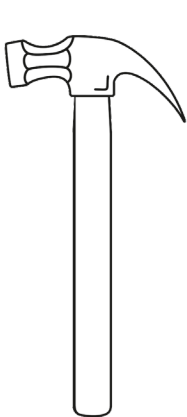

2 adultes recommandés
2 adults recommended

IMPORTANT AVANT DE DÉBUTER L'ASSEMBLAGE

- **Limitation de responsabilité:** We décline toute responsabilité en cas de blessures, de bris de matériel ou de pièces liés à l'assemblage.
- **Lire les instructions:** Veuillez lire ce guide complet avant de commencer l'assemblage.
- **Identifier les pièces:** Chaque pièce est numérotée. Référez-vous à la page de vue d'ensemble (page 5) pour identifier chaque élément.
- **Préparer les pièces:** Étalez toutes les pièces afin qu'elles soient facilement accessibles et prêtes pour l'assemblage.
- **Inspection des pièces:** Vérifiez chaque pièce pour vous assurer que les trous sont propres et libres de poussière.
- **Vérifier la quincaillerie:** Assurez-vous que toutes les vis et autres éléments nécessaires sont présents (page 3). Utilisez des contenants pour éviter de les perdre.
- **Outils nécessaires:** Avant de commencer, assurez-vous de disposer de tous les outils nécessaires pour l'assemblage.
- **Protection des pièces et du sol:** Utilisez la boîte en carton d'emballage ou un tapis pour protéger les pièces et le sol durant l'assemblage.

· **Lieu d'assemblage:** Effectuez l'assemblage le plus près possible de l'endroit où vous souhaitez installer votre commode.

· **Précautions de sécurité:** Les bords des pièces peuvent être coupants. Prenez les précautions nécessaires pour éviter les blessures.

· **Manipulation des pièces:** Manipulez les pièces avec soin et prenez votre temps. Ne forcez pas les éléments afin d'éviter d'endommager les pièces.

· **Fixation de l'armoire au mur:** Assurez-vous que la commode est correctement ancrée au mur pour éviter tout risque de blessure grave. Vous avez l'option d'utiliser le système anti-basculement inclus ou les vis de fixation incluses pour fixer dans les montants du murs. Les vis de fixation sont adaptées aux montants en bois. Utilisez des ancrages appropriés si le mur ou les montants du mur sont fait d'un autre matériel.

IMPORTANT BEFORE STARTING THE ASSEMBLY

- **Limitation of Liability:** We disclaims all liability for injuries, material damage or parts breakage related to the assembly.
- **Read the Instructions:** Please read this entire guide before starting the assembly.
- **Identify the Parts:** Each part is numbered. Refer to the overview page (page 5) to identify each piece.
- **Prepare the Parts:** Lay out all parts so they are easily accessible and ready for assembly.
- **Inspect the Parts:** Check each part to ensure that the holes are clean and free of dust.
- **Check the Hardware:** Ensure all screws and other necessary hardware are present (page 3). Use containers to keep the parts from being lost.
- **Required Tools:** Before beginning, make sure you have all the necessary tools for the assembly.

· **Protect the Parts and Floor:** Use the packaging box or a mat to protect the parts and the floor during assembly.

· **Assembly Location:** Assemble the cabinet as close as possible to the final placement location.

· **Safety Precautions:** The edges of the parts may be sharp. Take necessary precautions to avoid injury.

· **Handle Parts Carefully:** Handle the parts gently and take your time. Do not force any pieces to avoid damage.

· **Securing the cabinet to the Wall:** Make sure the cabinet is securely anchored to the wall to avoid any risk of serious injury. You have the option of using the provided furniture tipping restraint kit or the provided anchoring screws to fix into wall studs. The provided screws are for wooden wall studs. Use appropriate anchors if the wall or wall studs are made of other materials.

Quincaillerie - Hardware

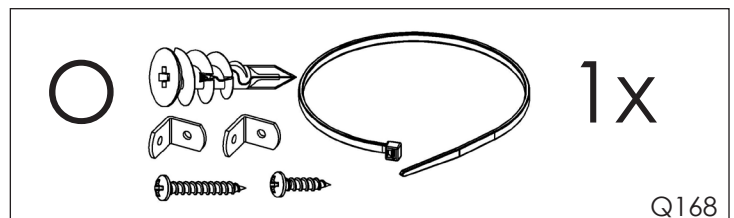
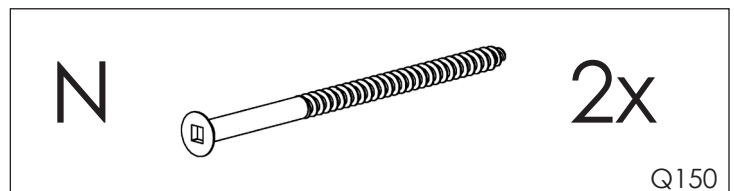
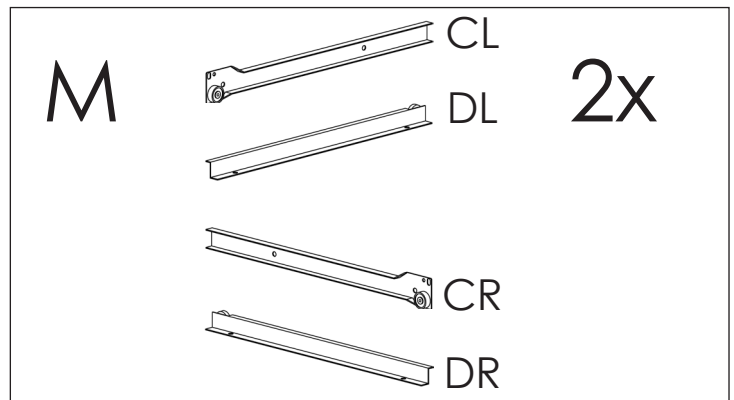
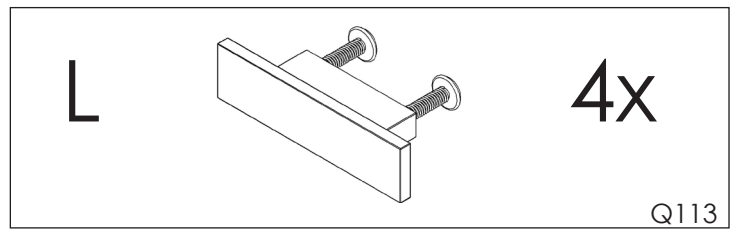
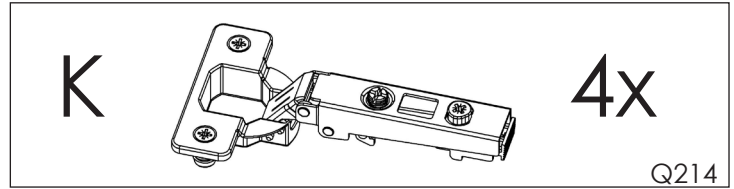
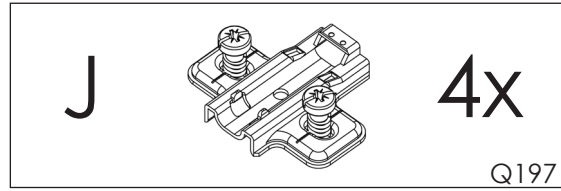
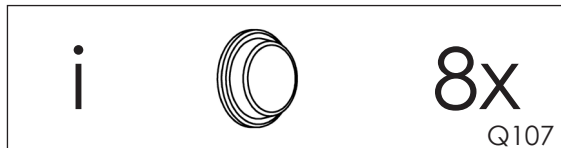
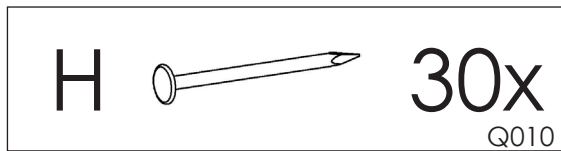
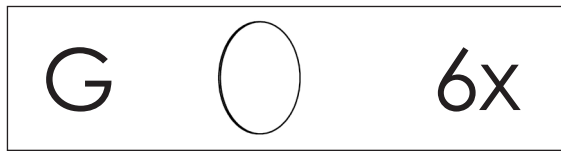
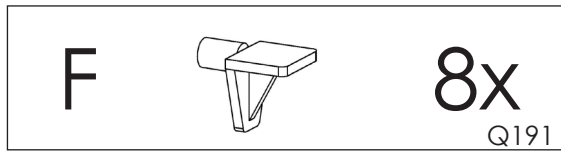
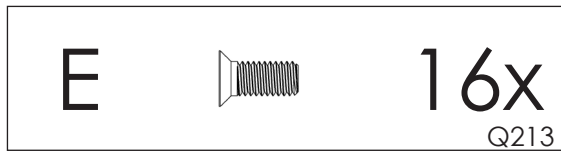
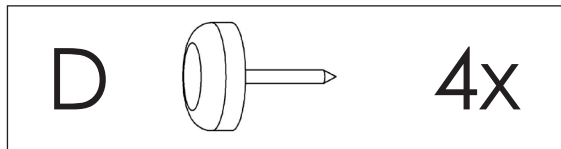
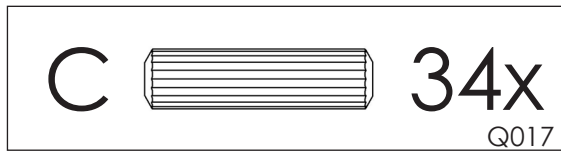
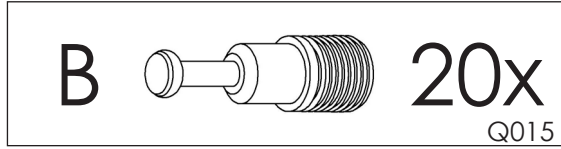
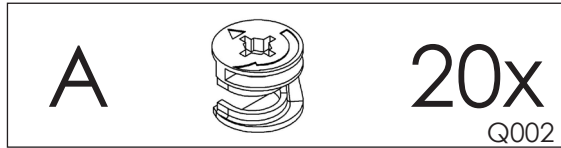



À retenir durant l'assemblage / Things to remember during assembly

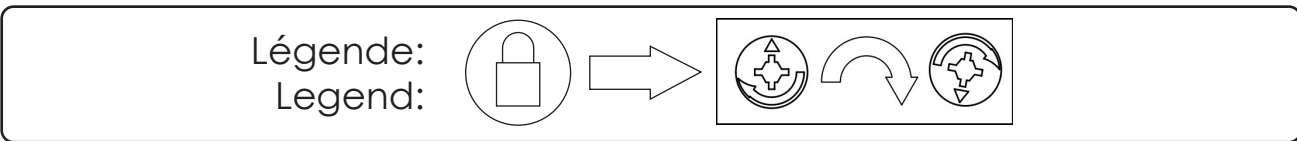
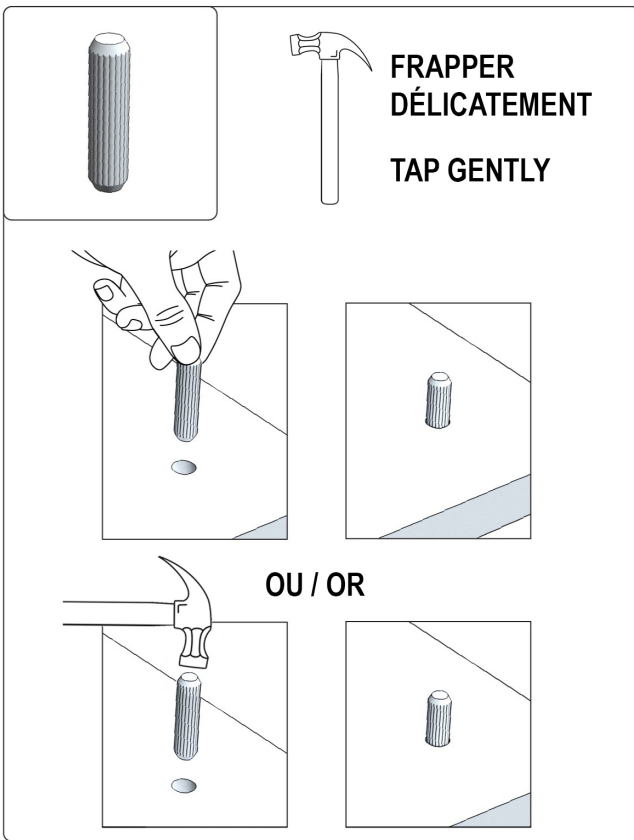
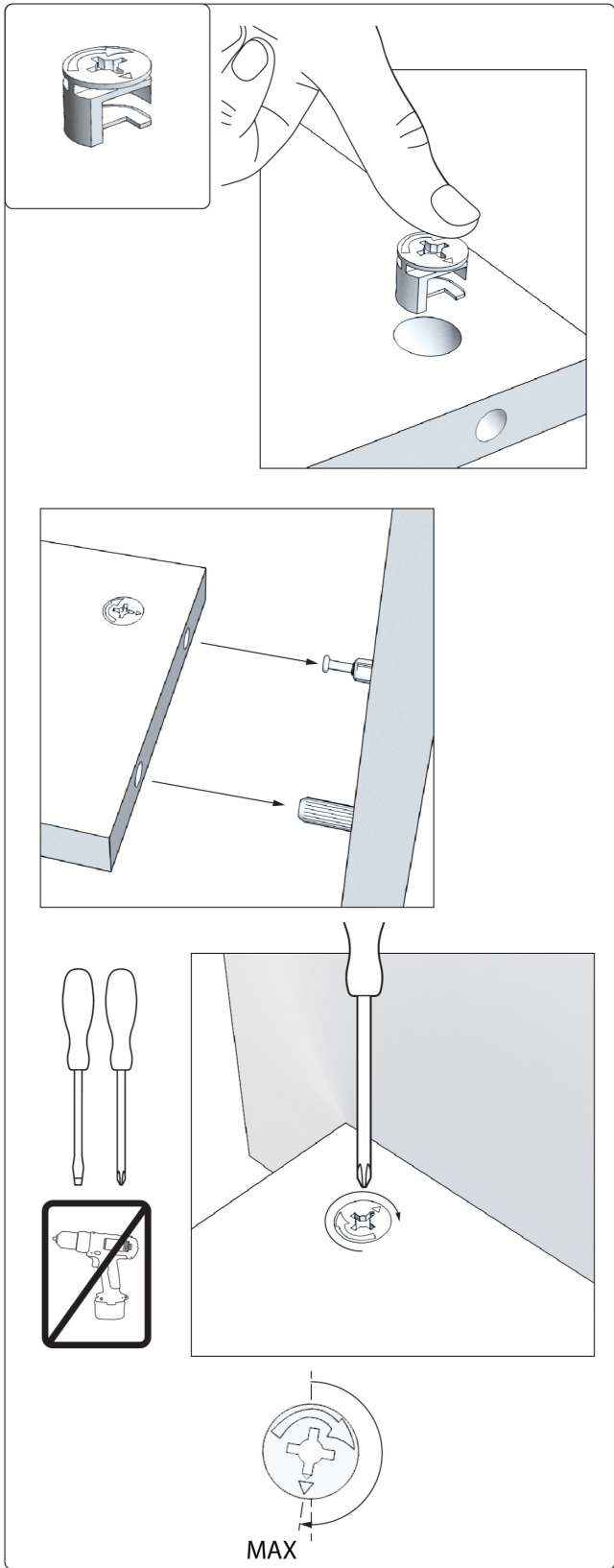
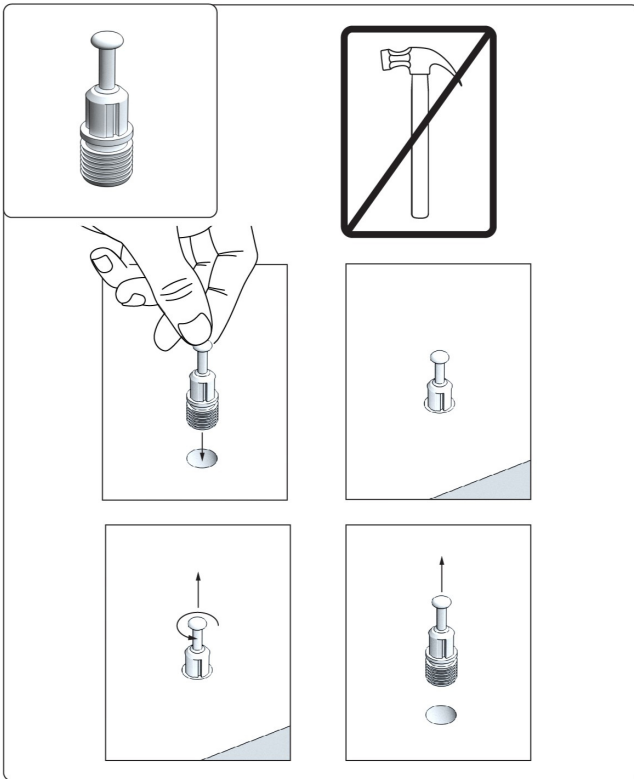





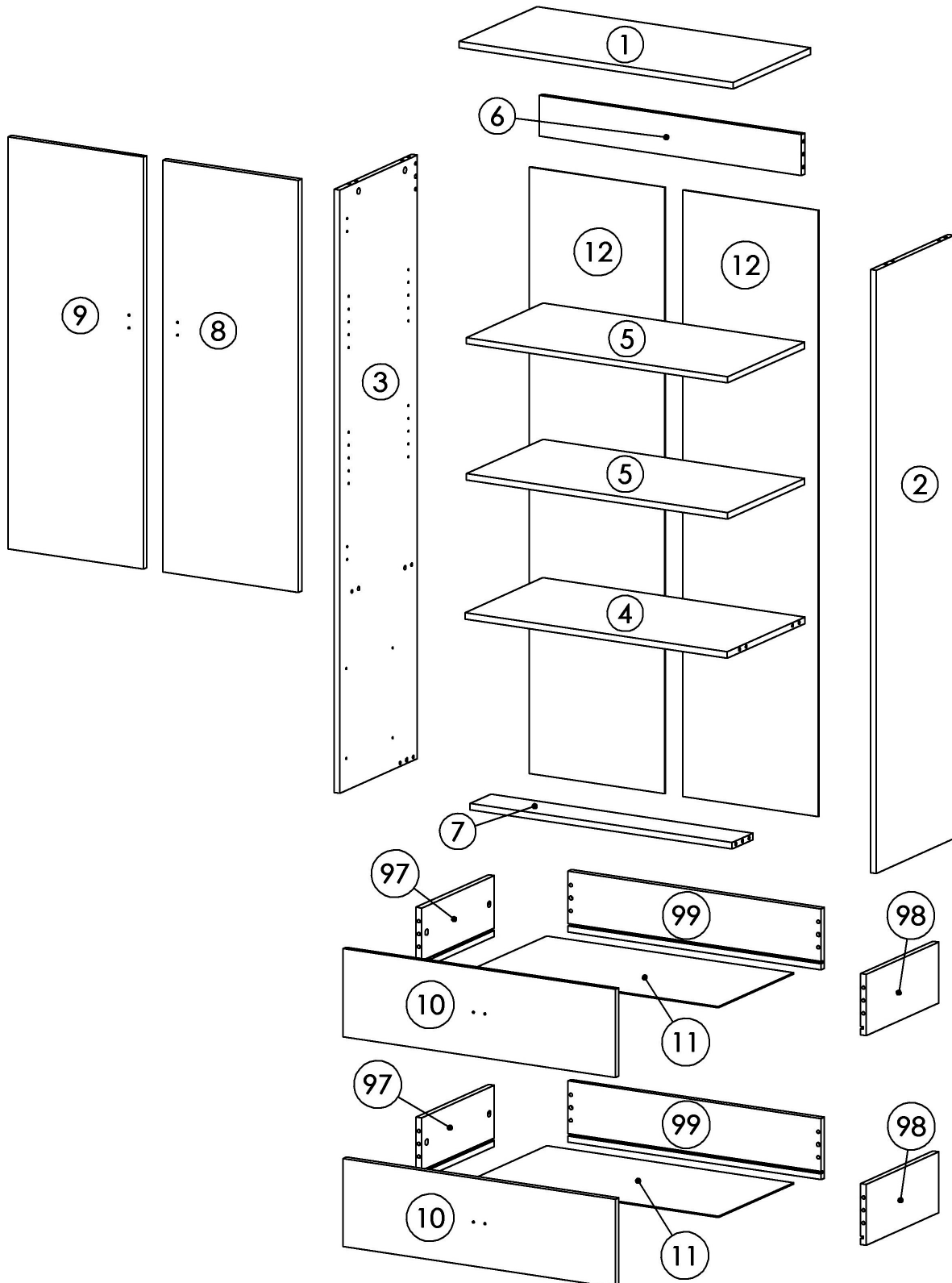

VUE D'ENSEMBLE OVERVIEW

Conservez cette page pour référence des numéros de pièce
Keep this page as a reference for part numbers

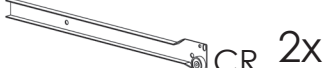

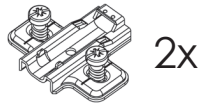
1 Côté droit Right side

- | | | |
|----------------------------------------------------------------------------------------|----------------------------------------------------------------------------------------|--------------------------------------------------------------------------------------------|
| A  2x | D  2x | M  CR 2x |
| B  4x | J  2x | |
| C  6x | E  4x | |

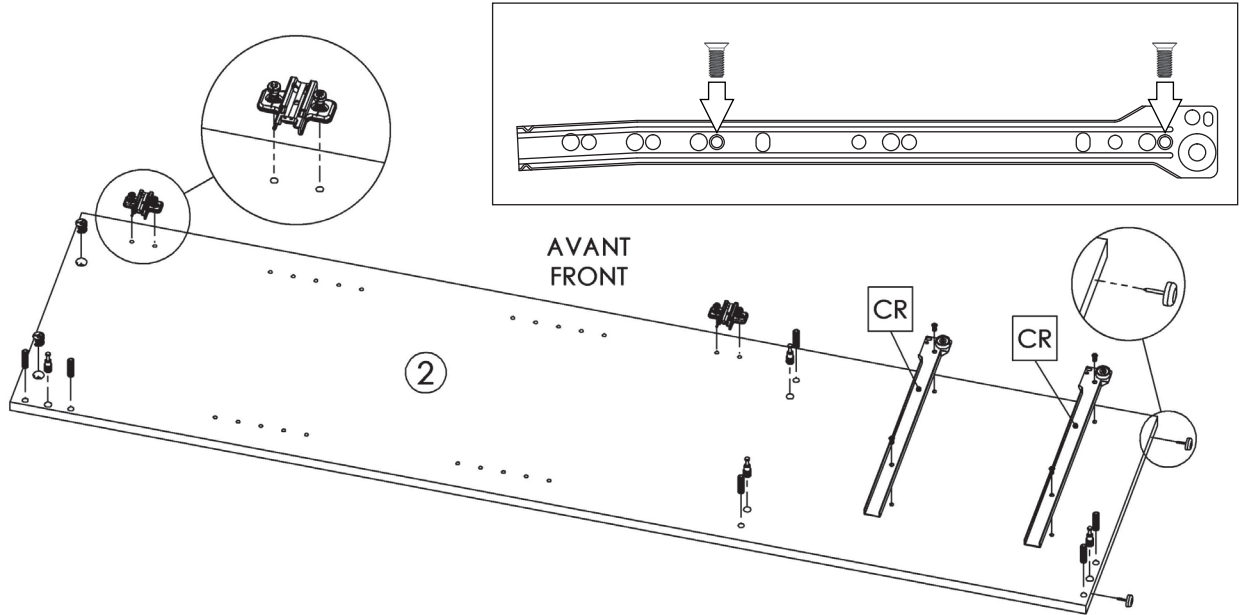
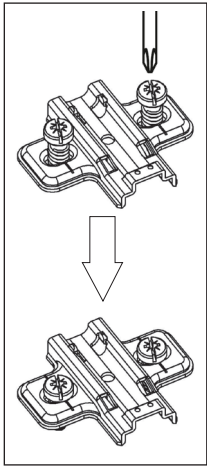
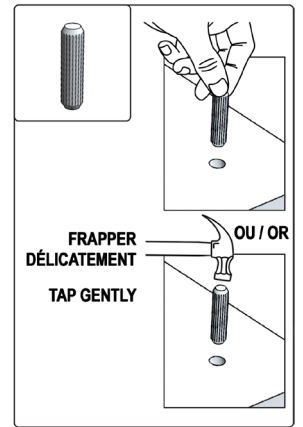

2 Tablette fixe, supports Fixed shelf, supports

- A  8x

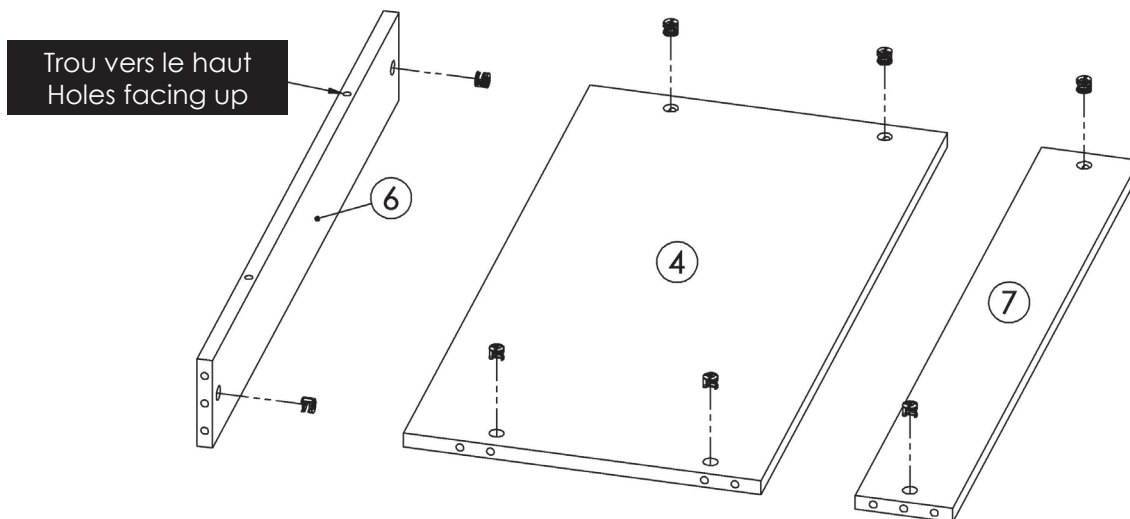

3 Assemblage de la tablette fixe et des supports Assembly of the fixed shelf & supports

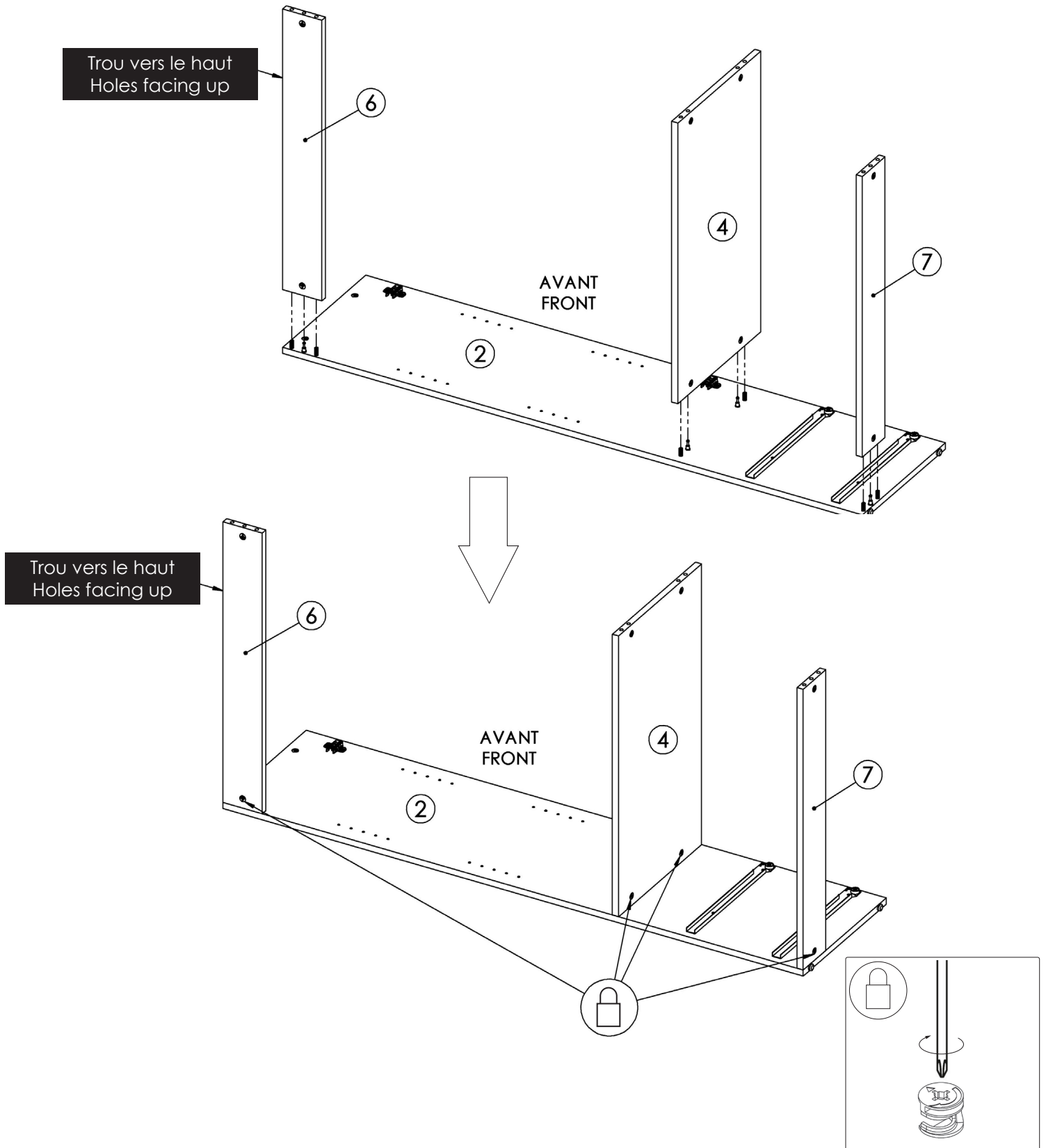

4 Basculer Flip

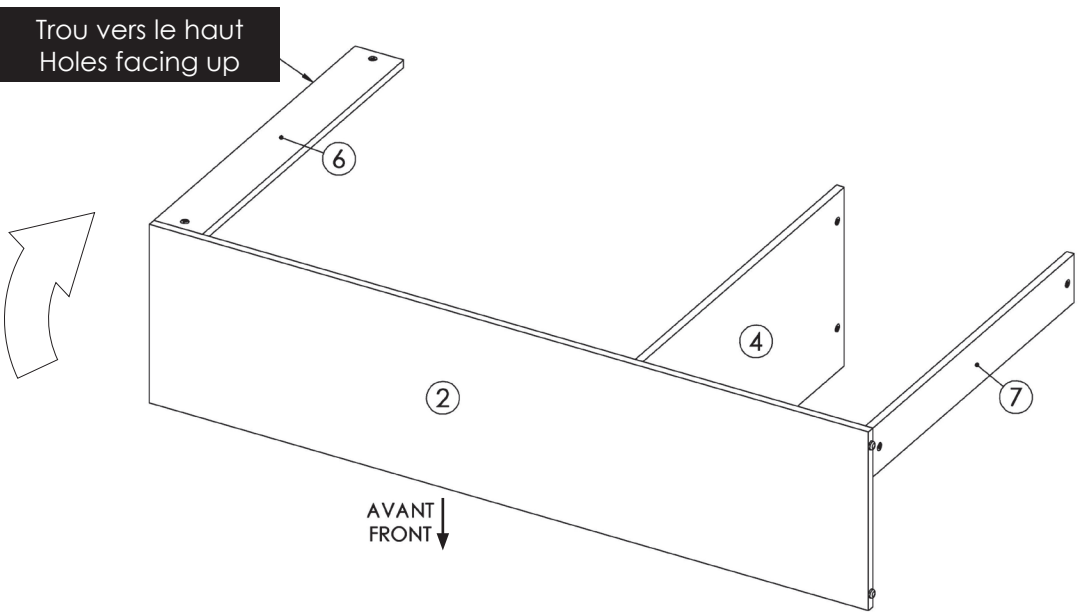

5 Côté gauche Lefs side

- | | | | | | | | | | |
|---|--|----|---|--|----|---|--|----|----|
| A | | 2x | D | | 2x | M | | CL | 2x |
| B | | 4x | J | | 2x | | | | |
| C | | 6x | E | | 4x | | | | |

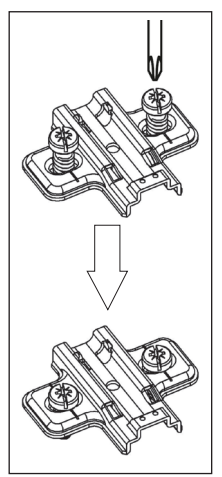
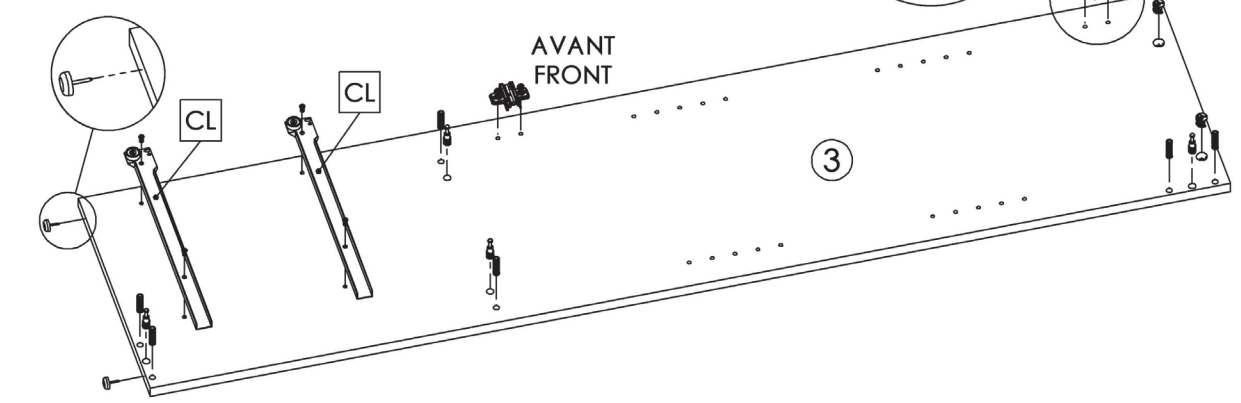
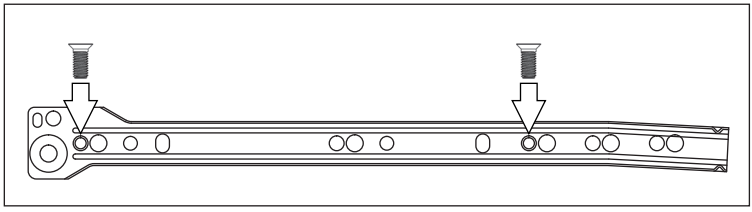
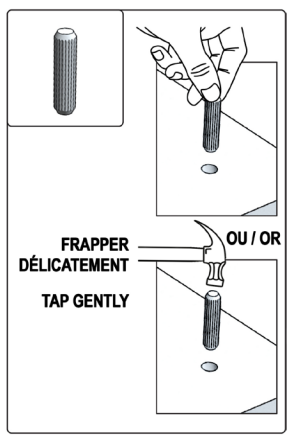

6 Assemblage du côté gauche Assembly of the left side

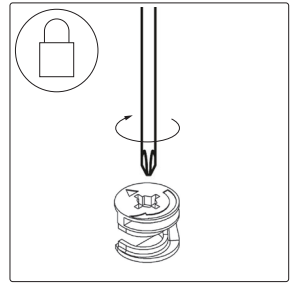
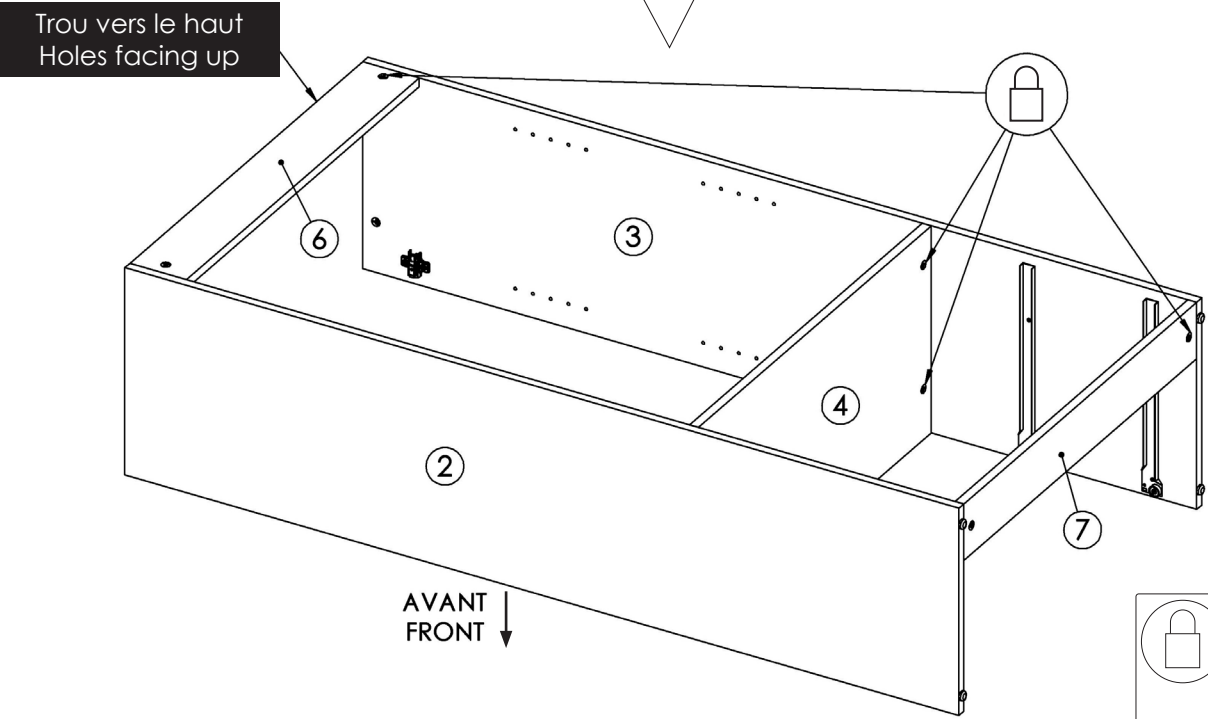
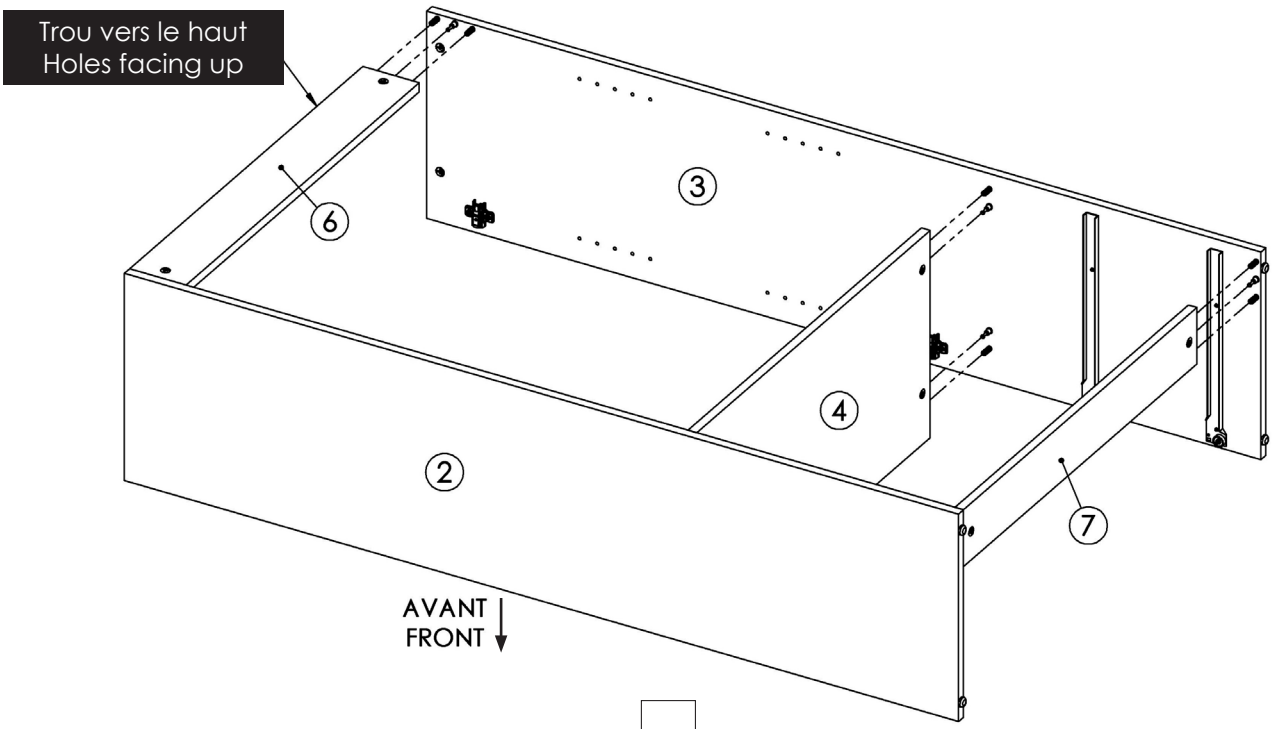

7 Dessus Top

- B  4x C  6x

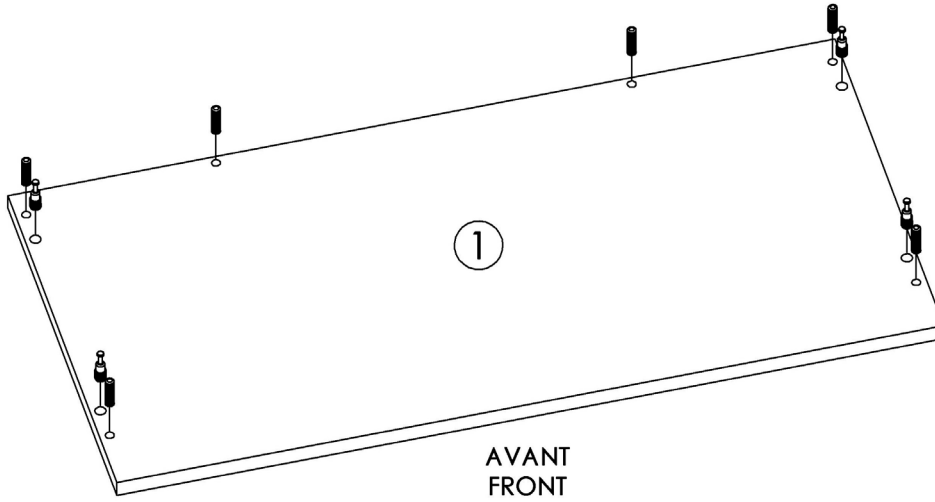
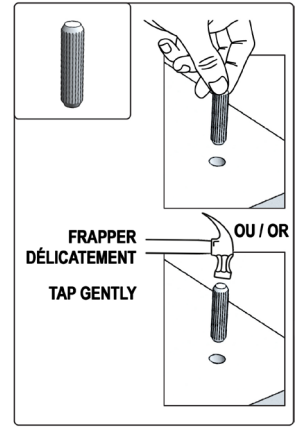

8 Assemblage du dessus Assembly of the top

- G  4x

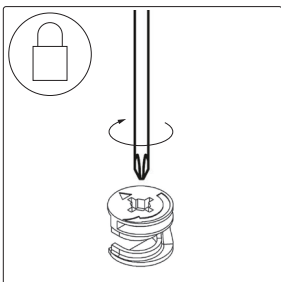
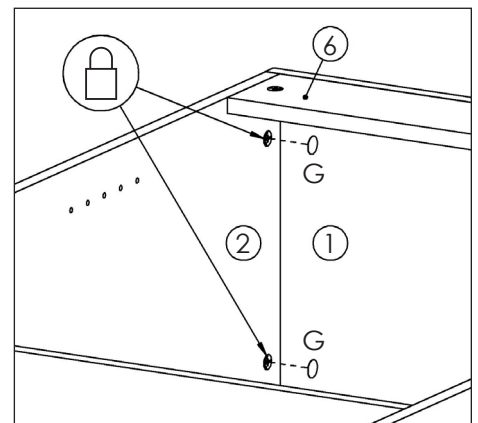
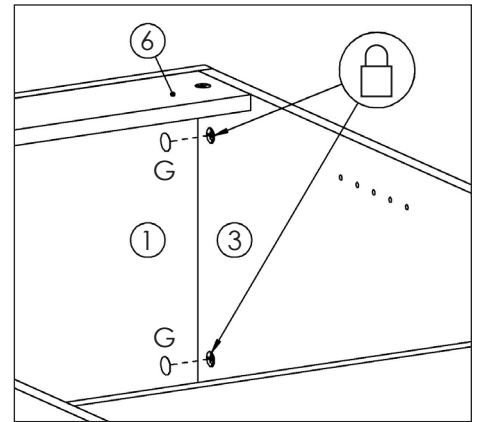
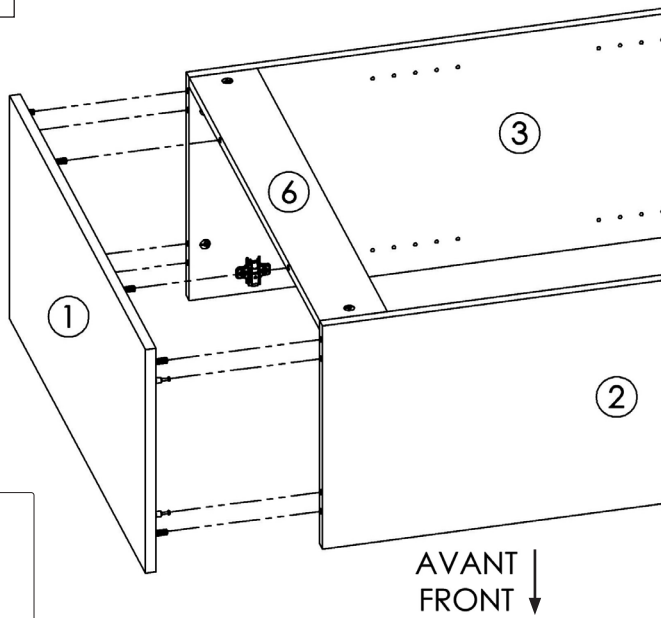

9 Marquage du centre de la tablette fixe
Marking the center of the fixed shelf

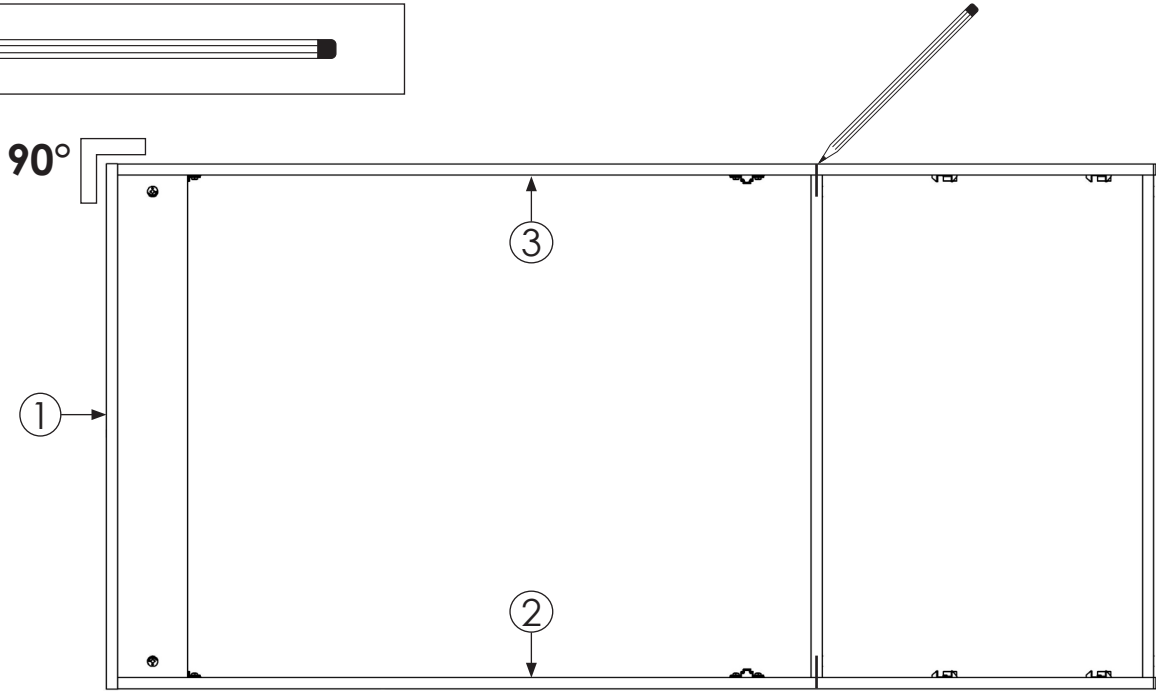

10 Placement des dos
Placing the backs

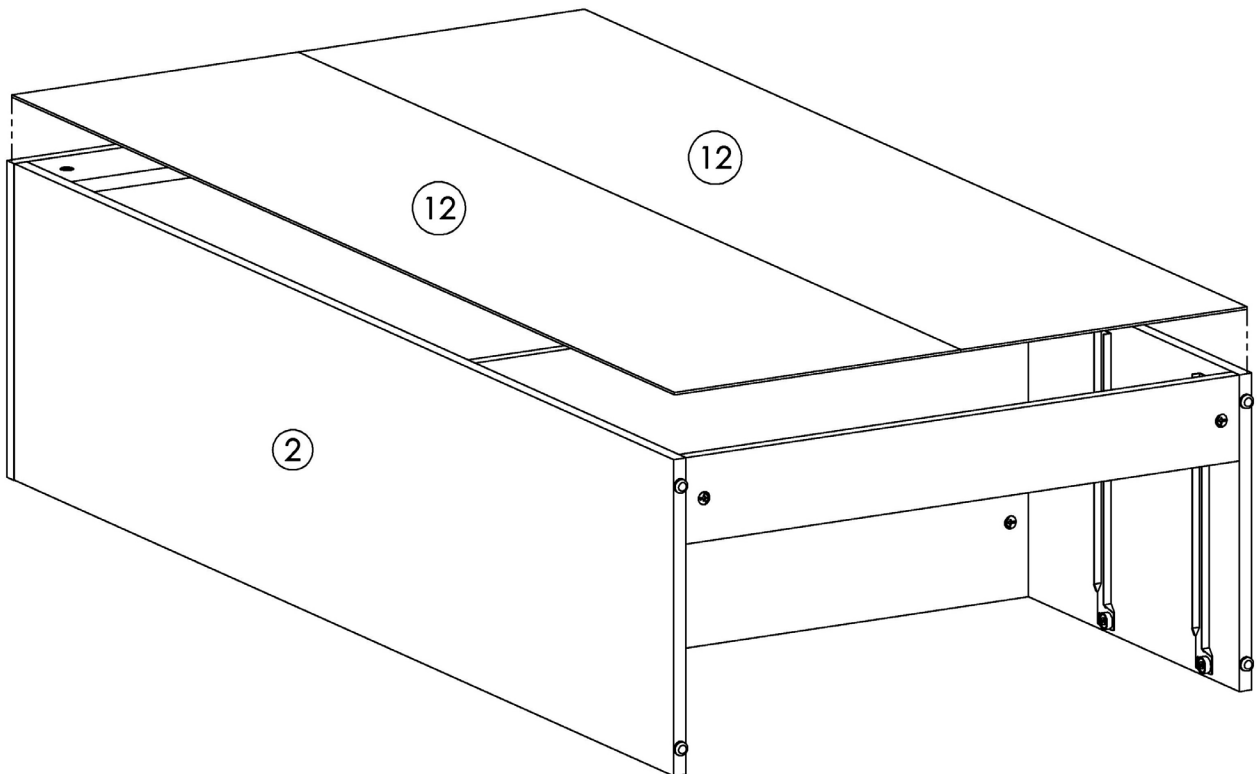

11 Marquage des dos Marking of the backs

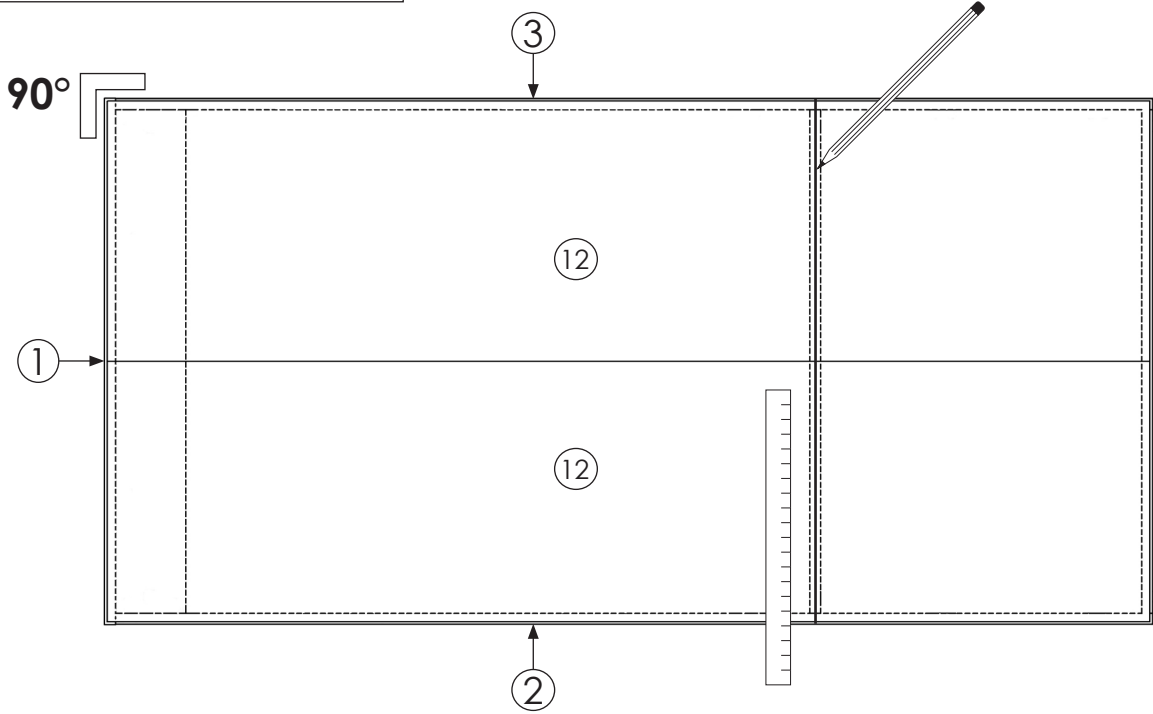
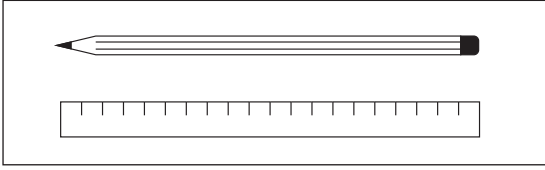

12 Fixation des dos Fixing the backs

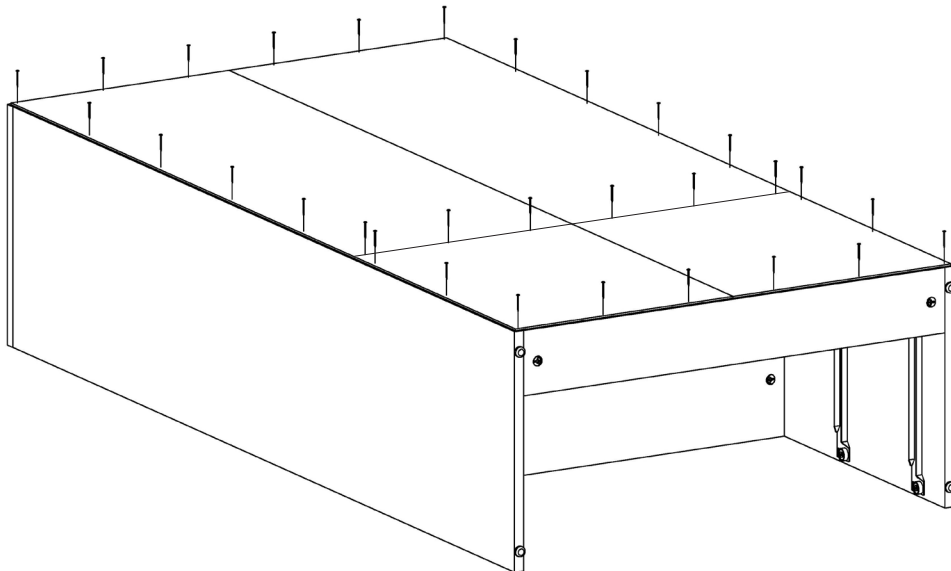
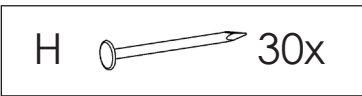

13 Basculer Flip

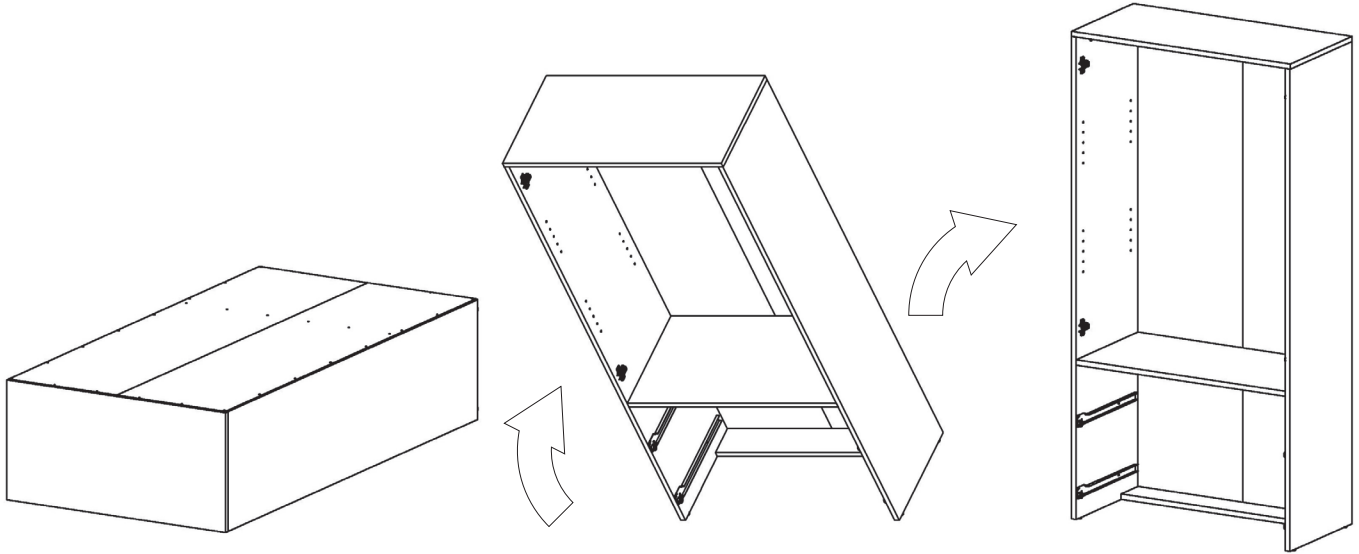

14 Portes gauche et droite Left & right doors

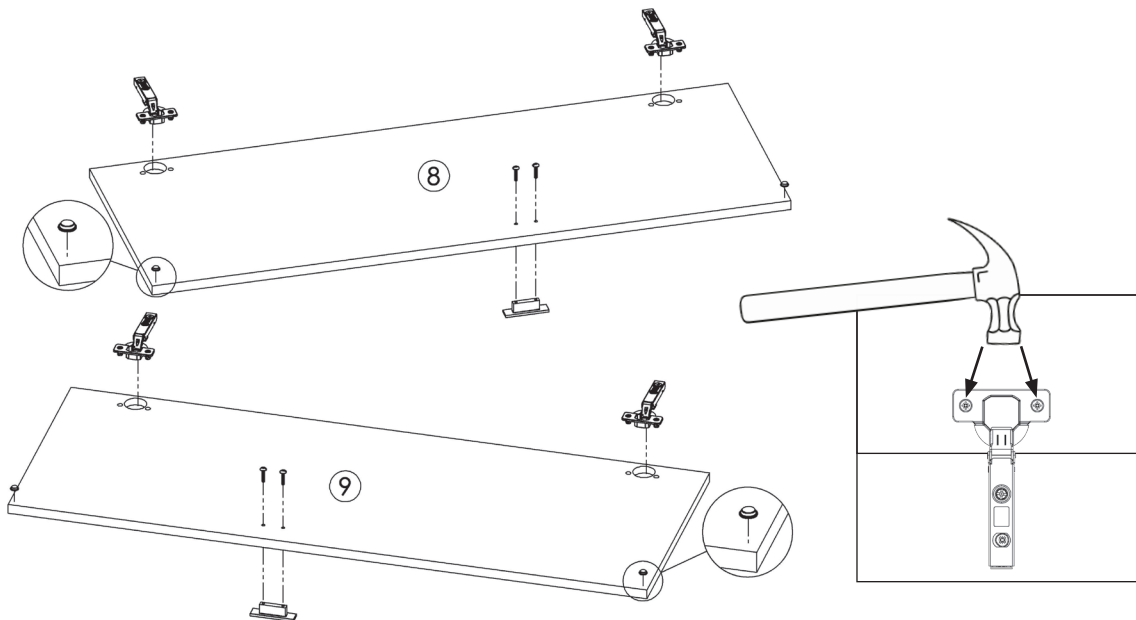
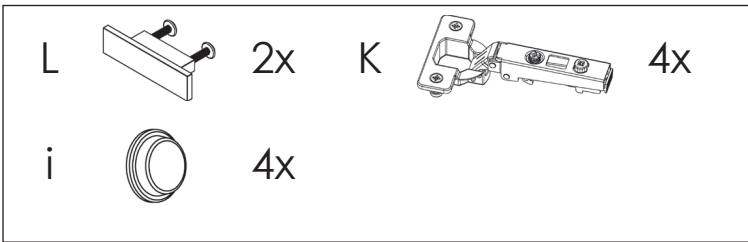

ATTENTION:
RISQUE DE BRIS
WARNING:
RISK OF BREAKING

**FRAPPEZ DÉLICATEMENT
AUX ENDROITS
INDIQUÉS**
**TAP GENTLY
ON INDICATED
AREAS**

15 Insertion des portes gauche et droite Inserting the left & right doors

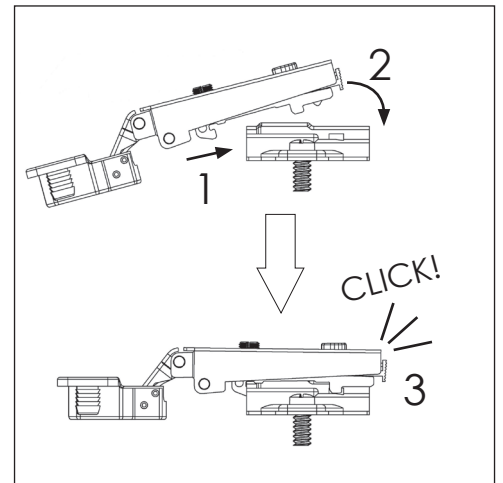
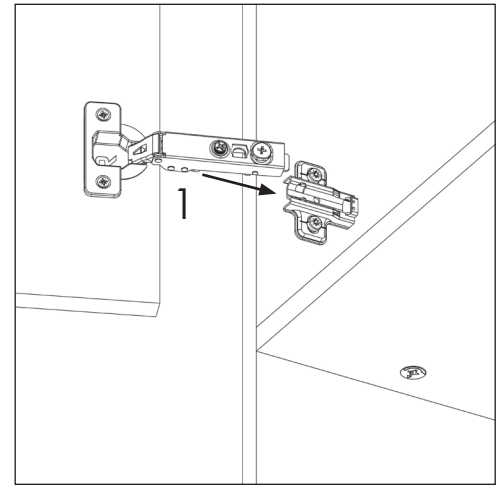
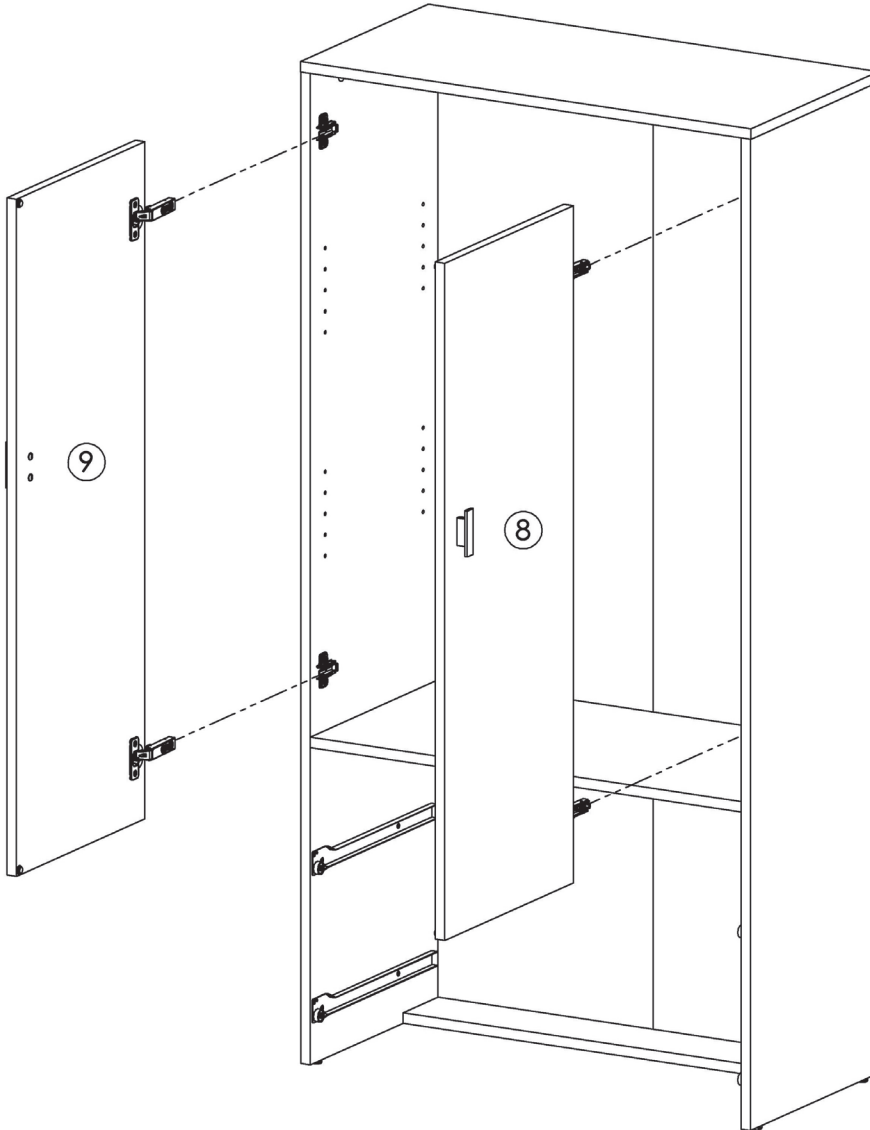

Sécurisez la penture du bas en premier et sécurisez la penture du haut par la suite.
Secure the bottom hinge first then secure the top hinge next.

AJUSTEMENTS ADJUSTMENTS

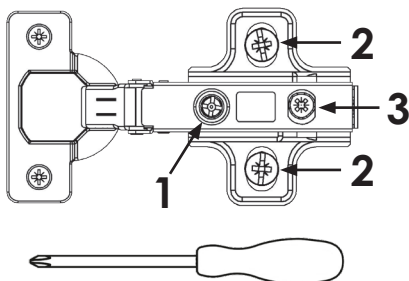

1. De côté
Side-to-side
2. Verticalement
Vertically
3. Avant-arrière
Front-to-back



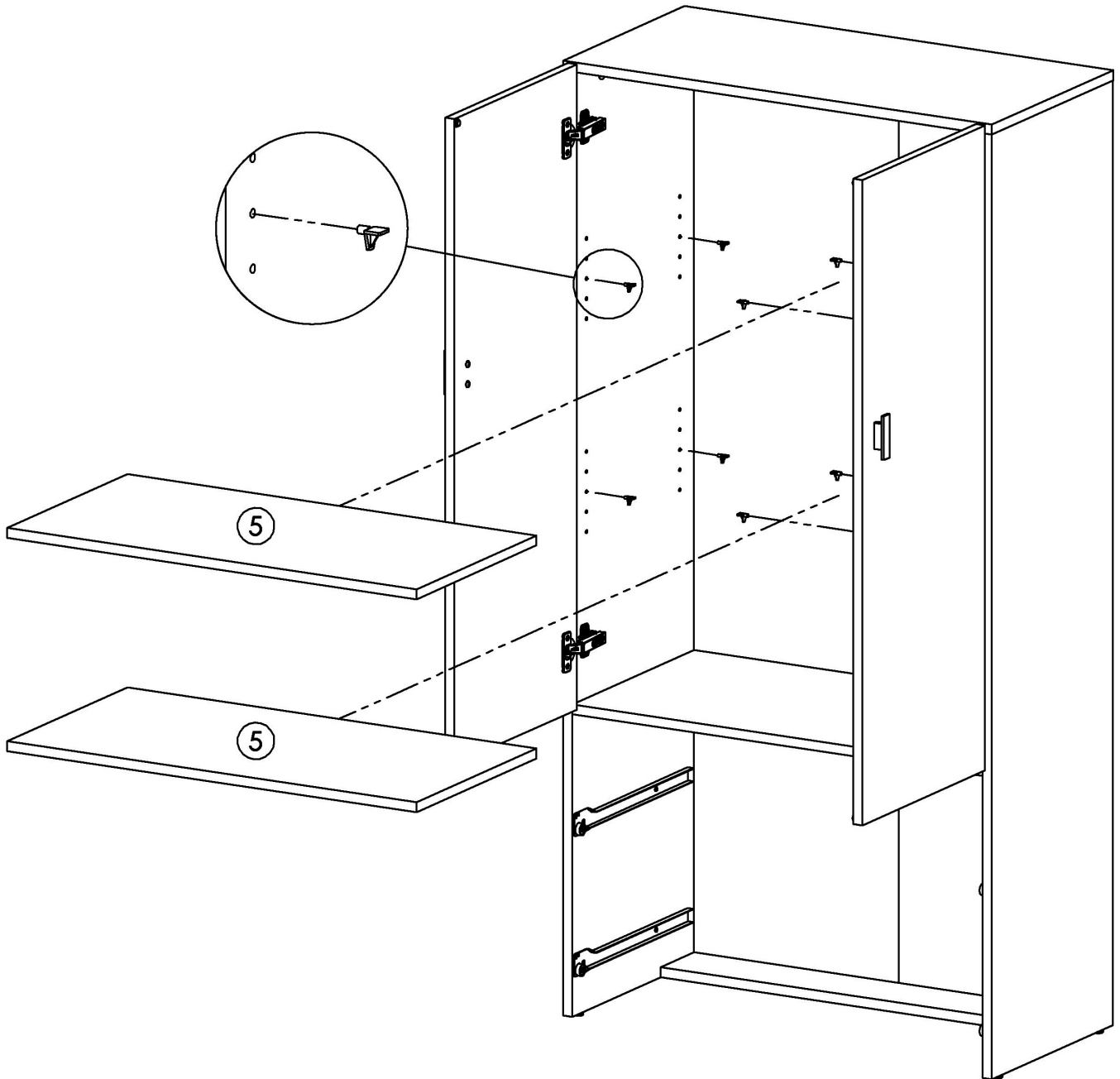
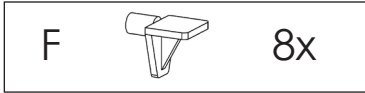

16

Insertion des tablettes amovibles
Inserting the removable shelves

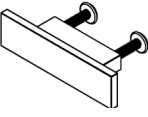

17

Facades, côtés et derrières de tiroirs Fronts, sides & backs of the drawers

A		8x	B		8x	C		16x
L		2x	i		4x			

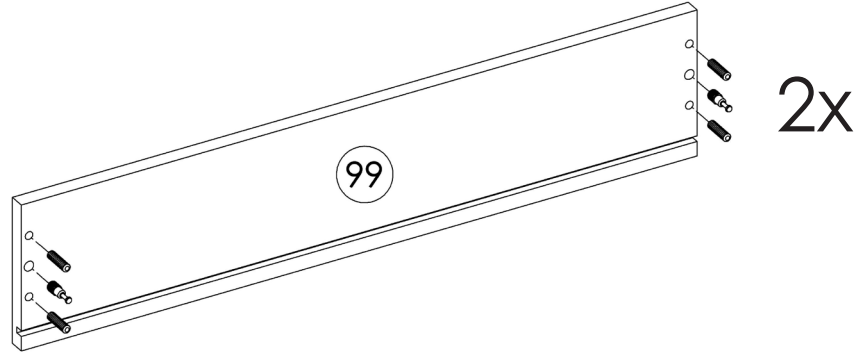
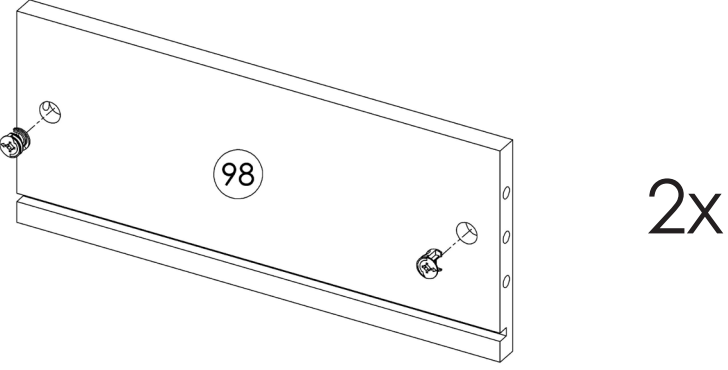
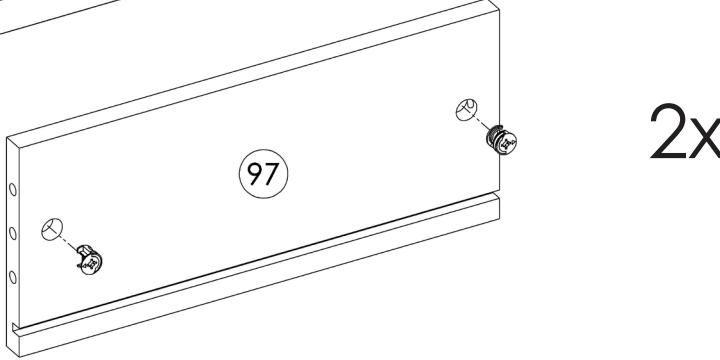
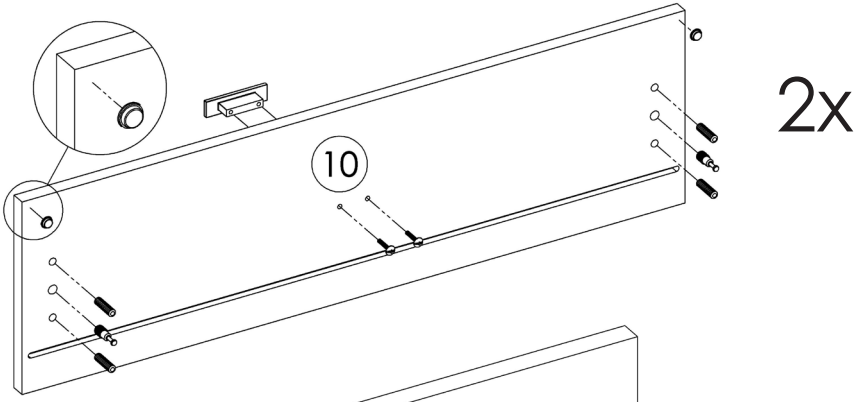

18

Assemblage de la facade et des côtés de tiroir Front & sides of the drawer assembly

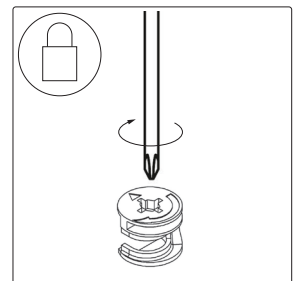
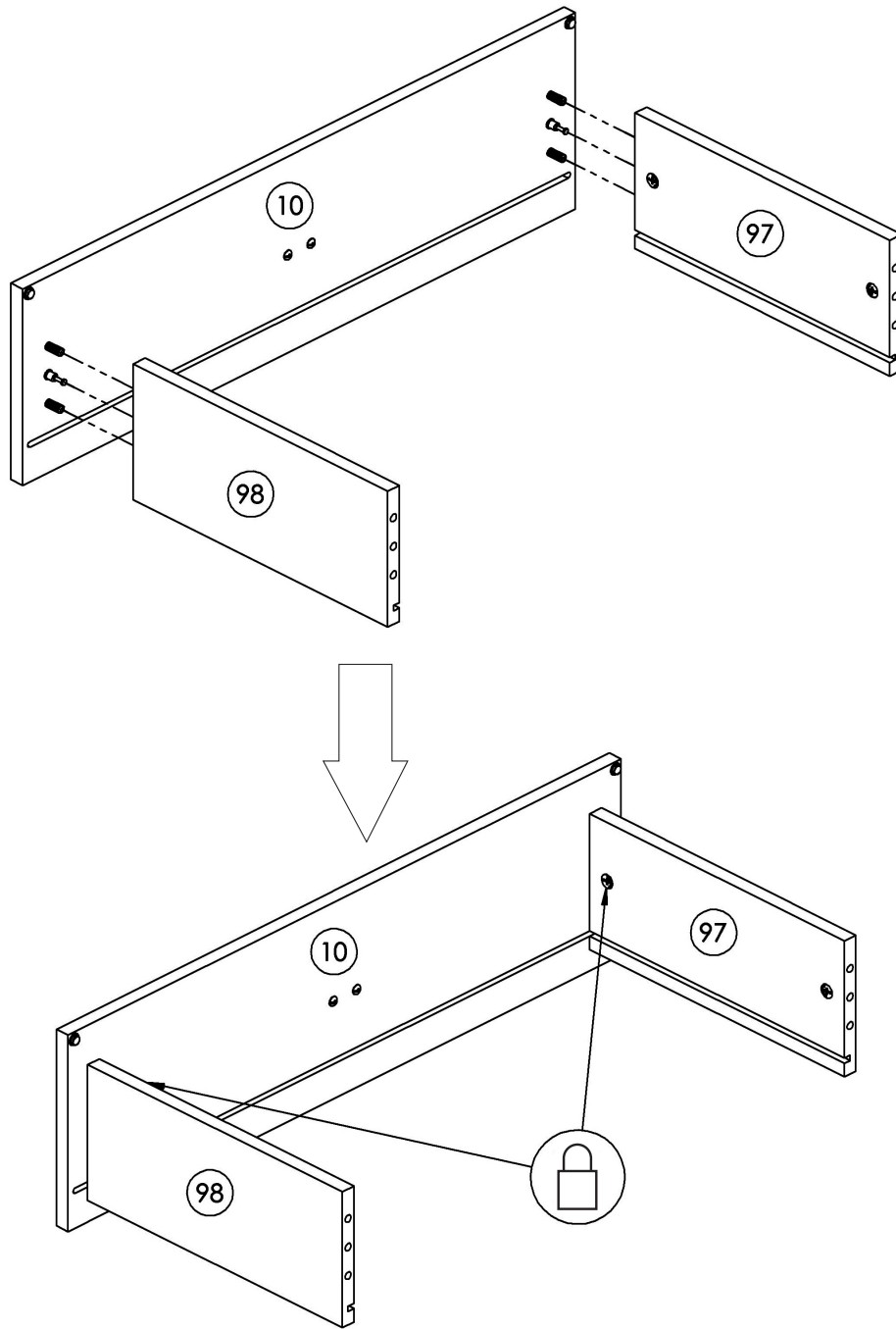

19

Inserion du fond et derriere de tiroir Bottom & back drawer assembly

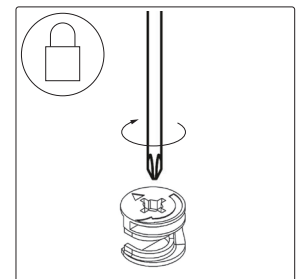
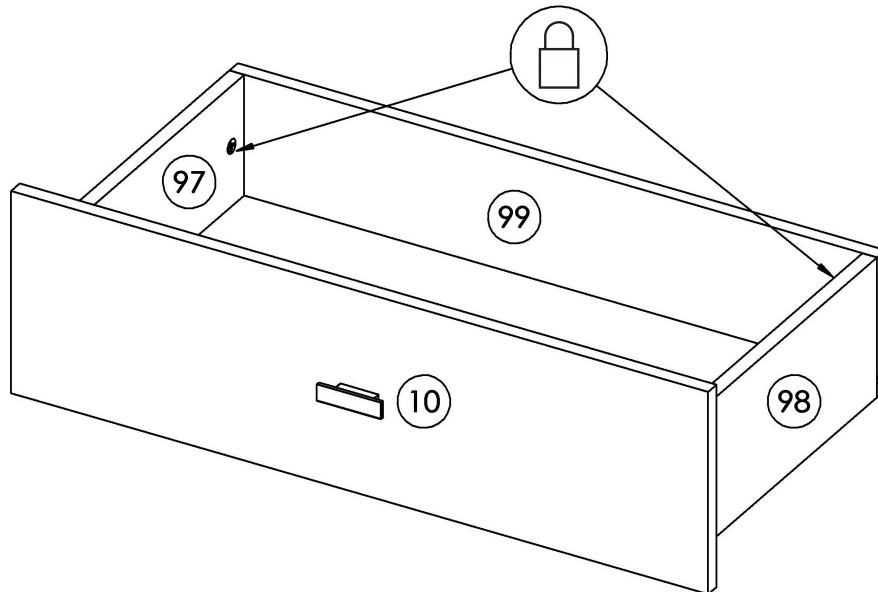
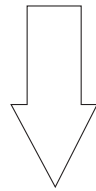
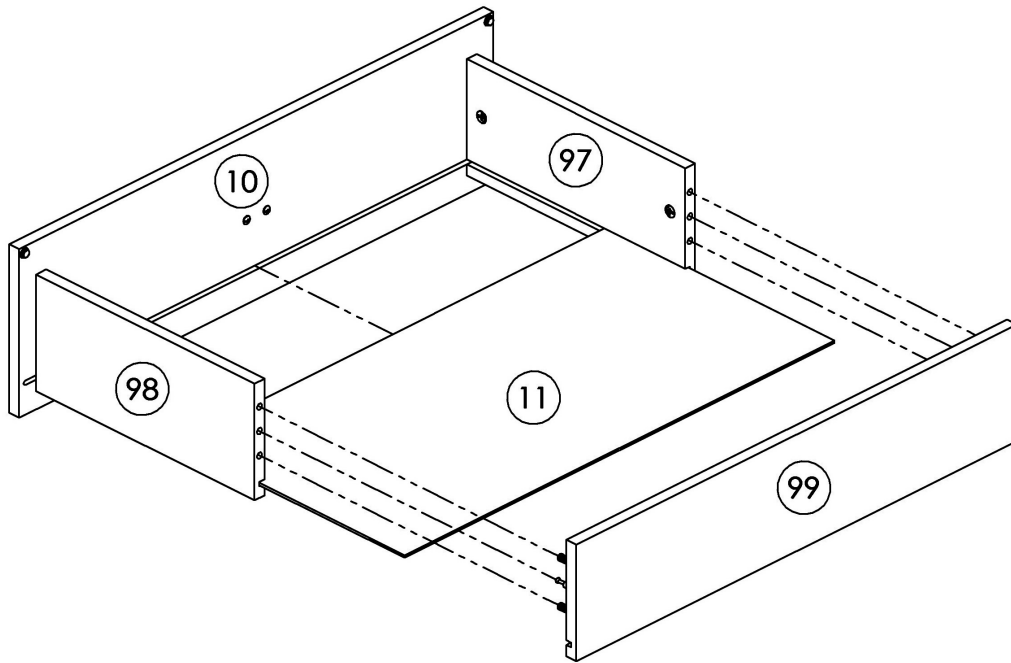

20

Coulisses Drawer slides

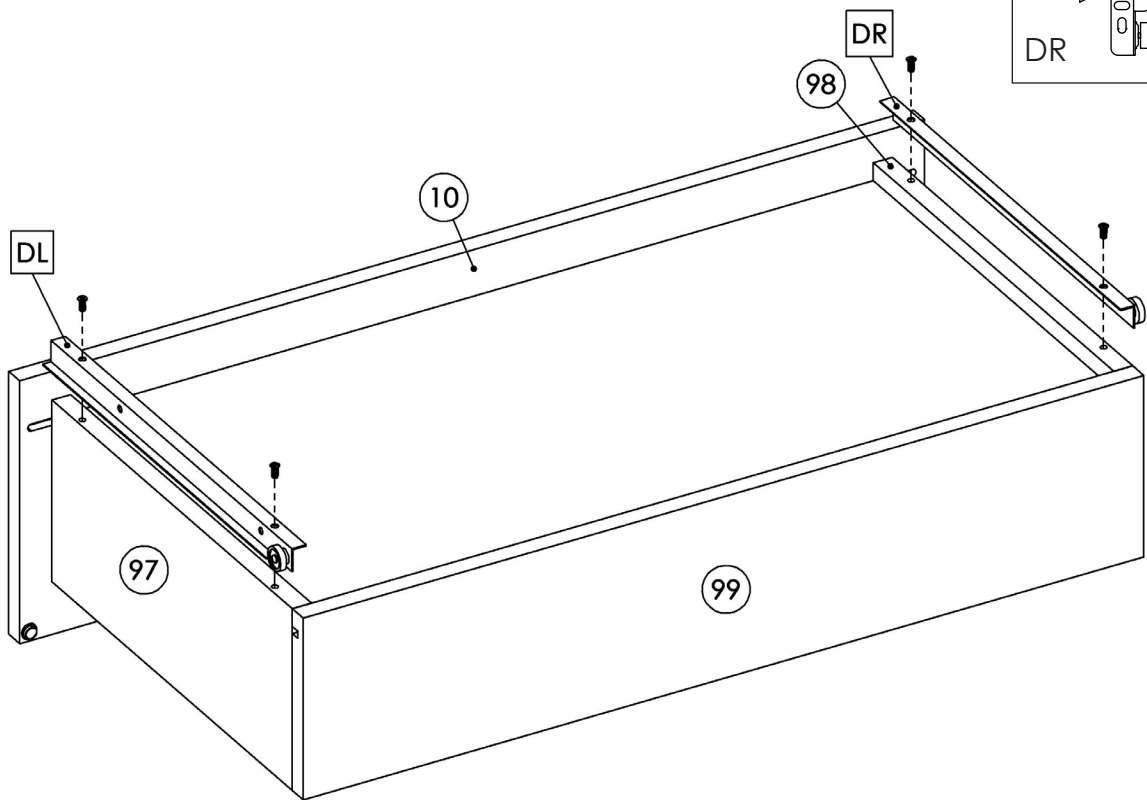
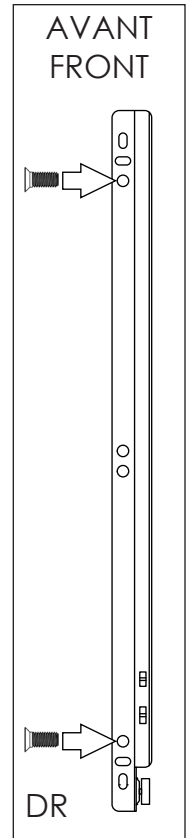
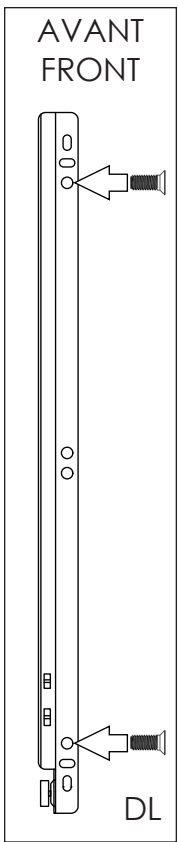
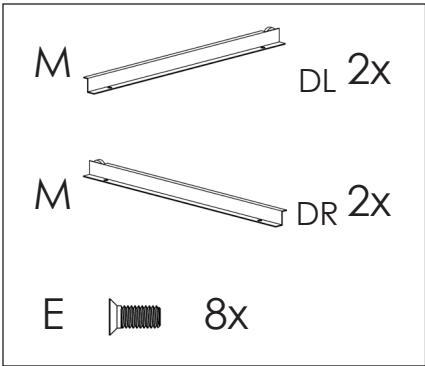

21

Inserion des tiroirs
Drawers insertion

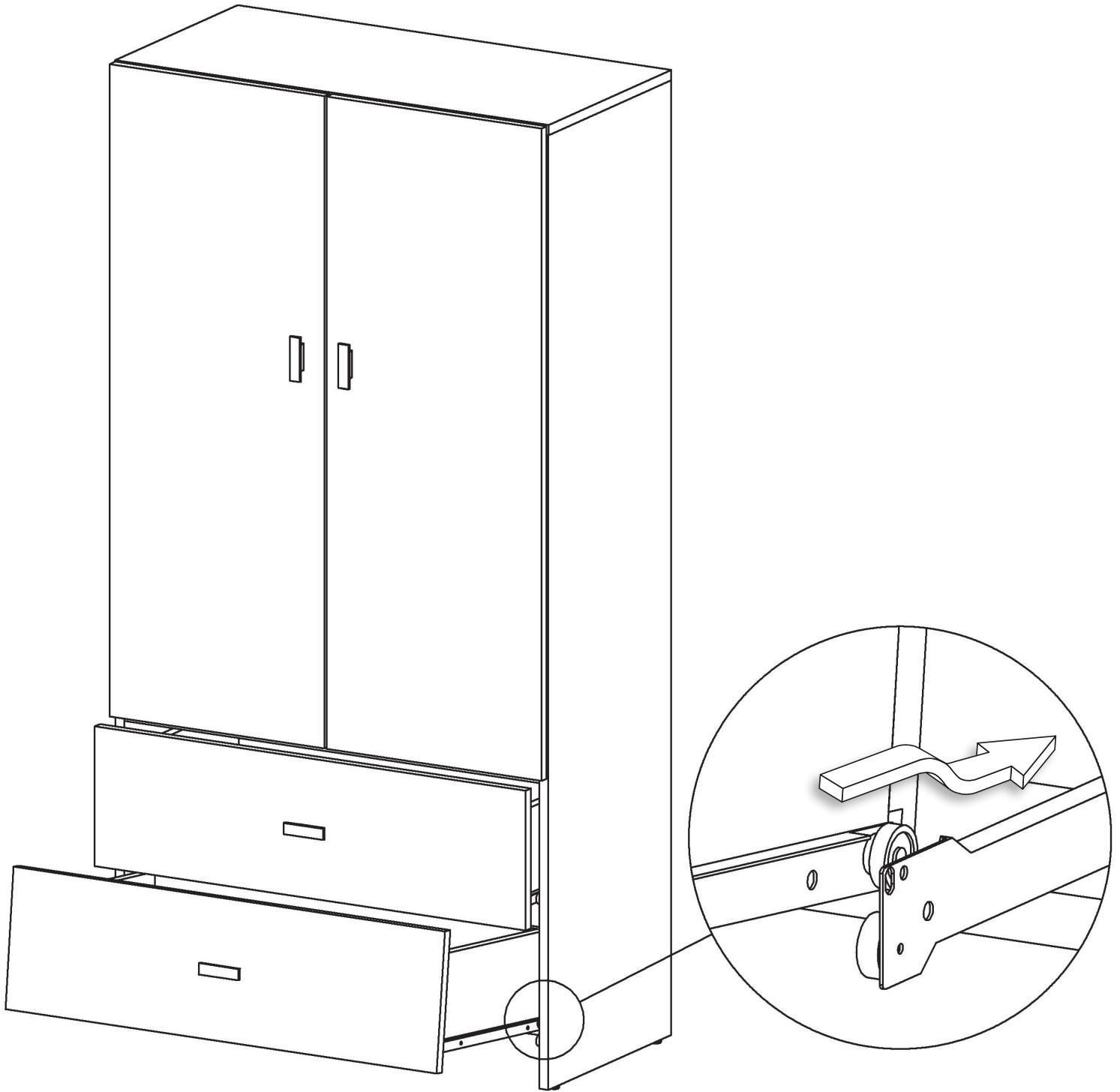

22 Systèmes anti-basculement Tipping restraint systems

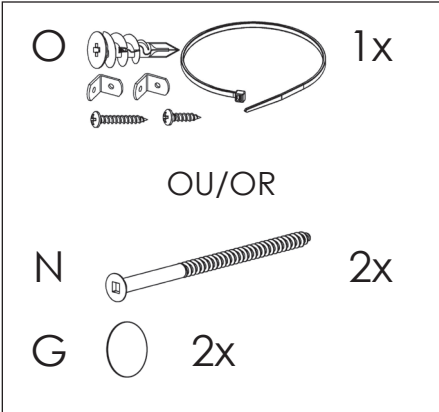

Suivre les instructions d'installation sur l'emballage du système anti-basculement "O".

OU

Trouvez les montants du mur et utilisez les vis "N" pour ancrer l'armoire au mur.

Follow the installation instructions on the tipping restraint system packaging "O".

OR

Find the wall studs and use the "N" screws to anchor the cabinet to the wall.

