

Assembly Instructions

BAR STOOL

CAUTION: You must read this before you proceed.

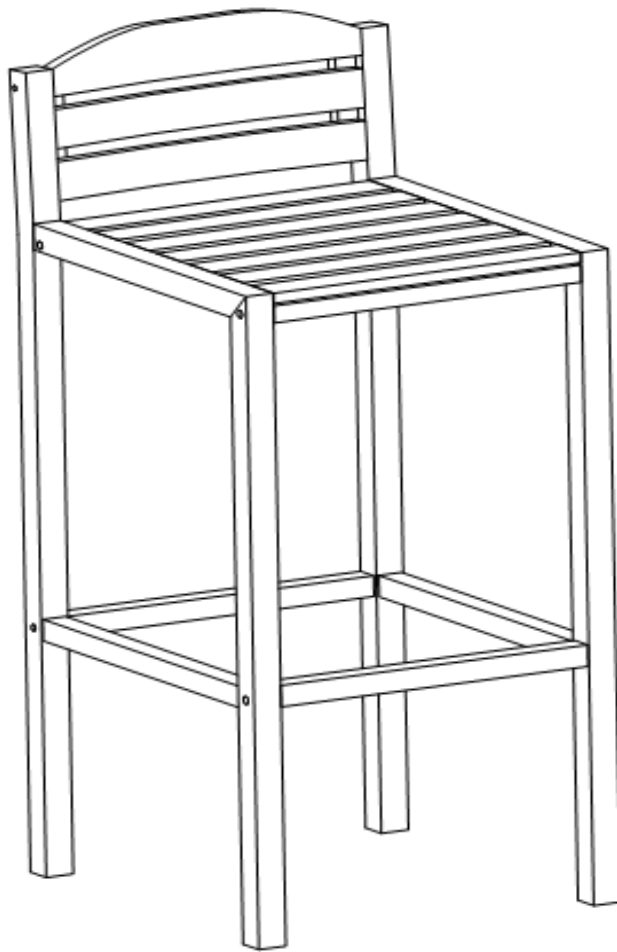

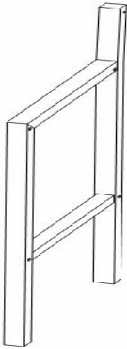
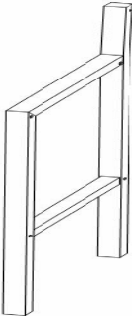
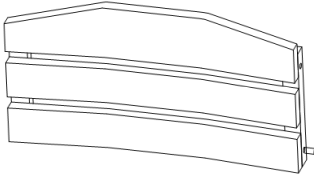
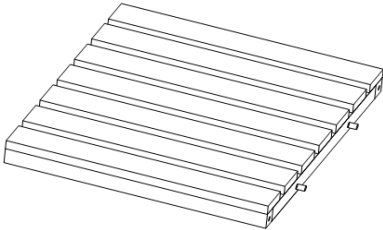
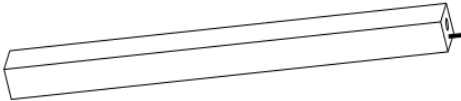

CAUTION : This Barstool is NOT a TOY.
Keep your child / children at bay during the assembly process.
For moving the Barstool and to prevent damage to the Barstool, two adults may be needed to execute this action.

Parts List

| No. | Picture | Description | Qty |
|-----|---|-----------------|-----|
| A1 |  | Left Leg Panel | 1 |
| A2 |  | Right Leg Panel | 1 |
| B |  | Backrest Panel | 1 |
| C |  | Seat Panel | 1 |
| D |  | Leg Connector | 2 |

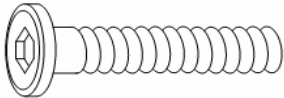
Hardware

| No. | Picture | Description | Qty |
|-----|---|----------------|-----|
| ① |  | Bolt (M6x45mm) | 11 |
| ② |  | Allen Key | 1 |

Assembly Preparation

Before Beginning Assembly:

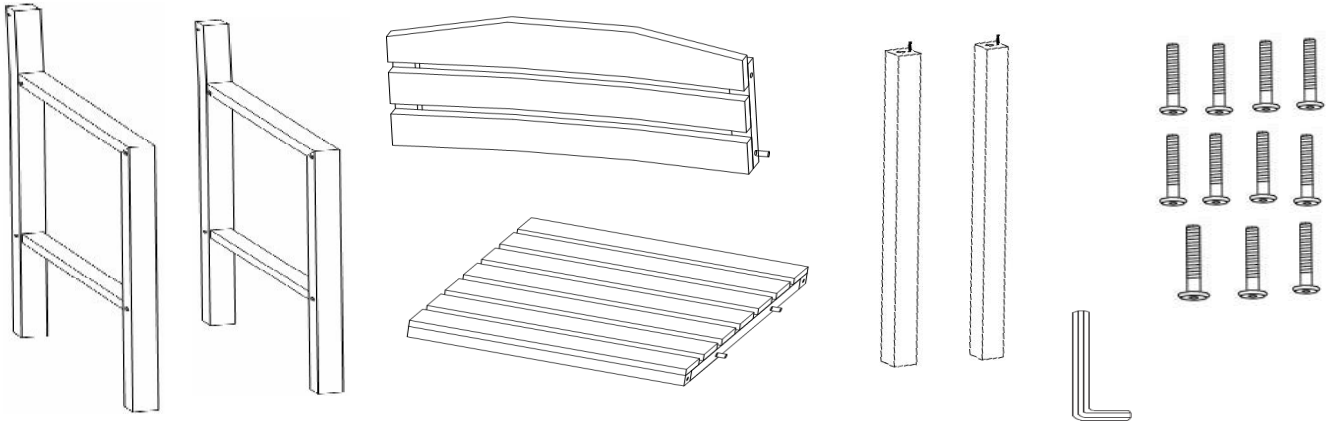

Read instructions, cover to cover.



Have 2 adults on hand for assembly.



Do not assemble on flooring or carpet.



Assemble on a clean non-marring surface (packing foam).



Save all packaging until finished.

Assembly Steps

OVERVIEW

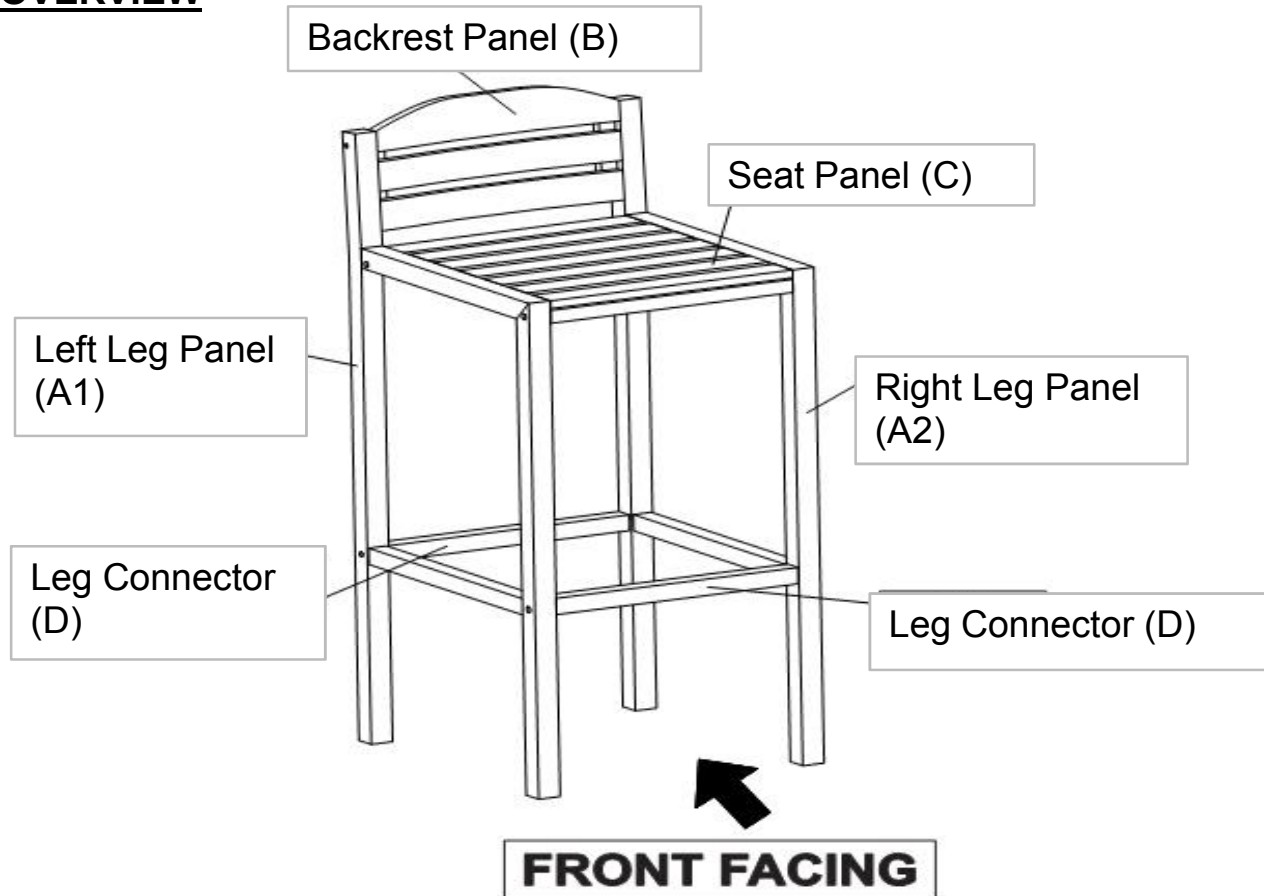

This Bar Stool has multiple parts and may require up to 30 minutes to assemble. To give you an overview of the Bar Stool parts, the above picture is to help you put the various parts into perspective. Please read through the instructions below to familiarise yourself with the parts and steps before assembly.

Step 1

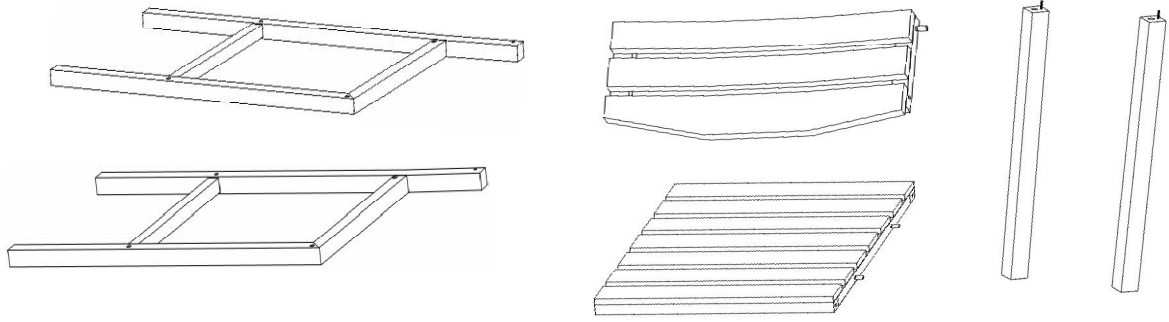

Unpack and place all parts on a clean, non-marring surface.

Step 2

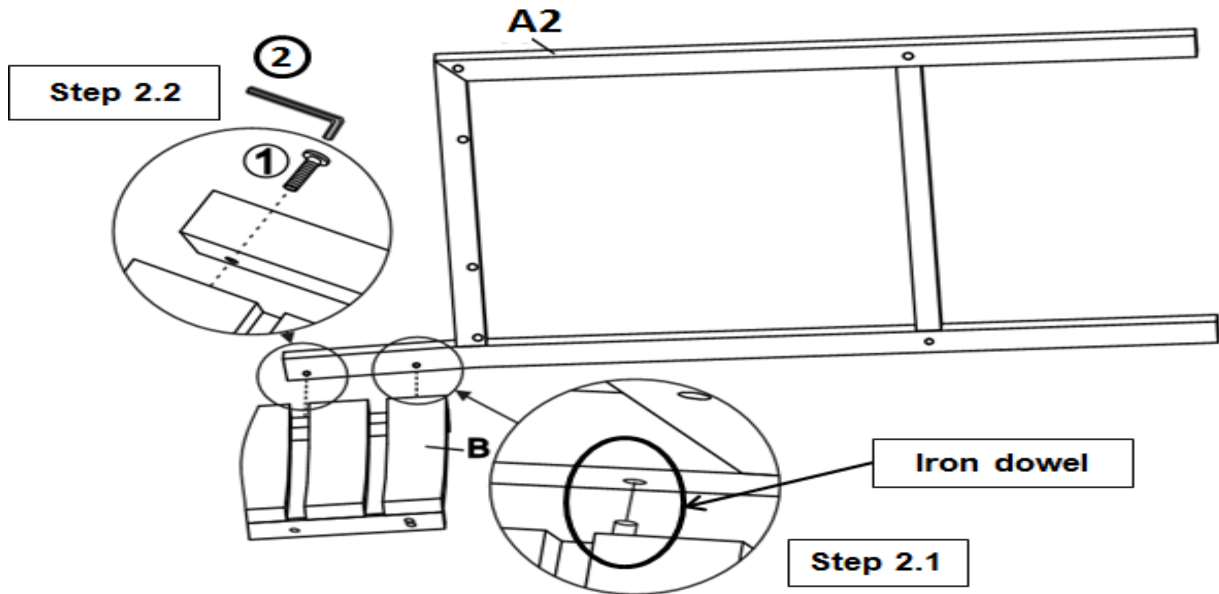

Place the Right Leg Panel (A2) at 90 degree onto a clean, non-marring surface.

2.1) Insert prefixed iron dowel of Backrest Panel (B) into housing of Right Leg Panel (A2).

2.2) Secure Backrest Panel (B) to Right Leg Panel (A2) by using Bolt (1) with Allen Key(2).

Do not fully tighten the Bolt.

Step 3

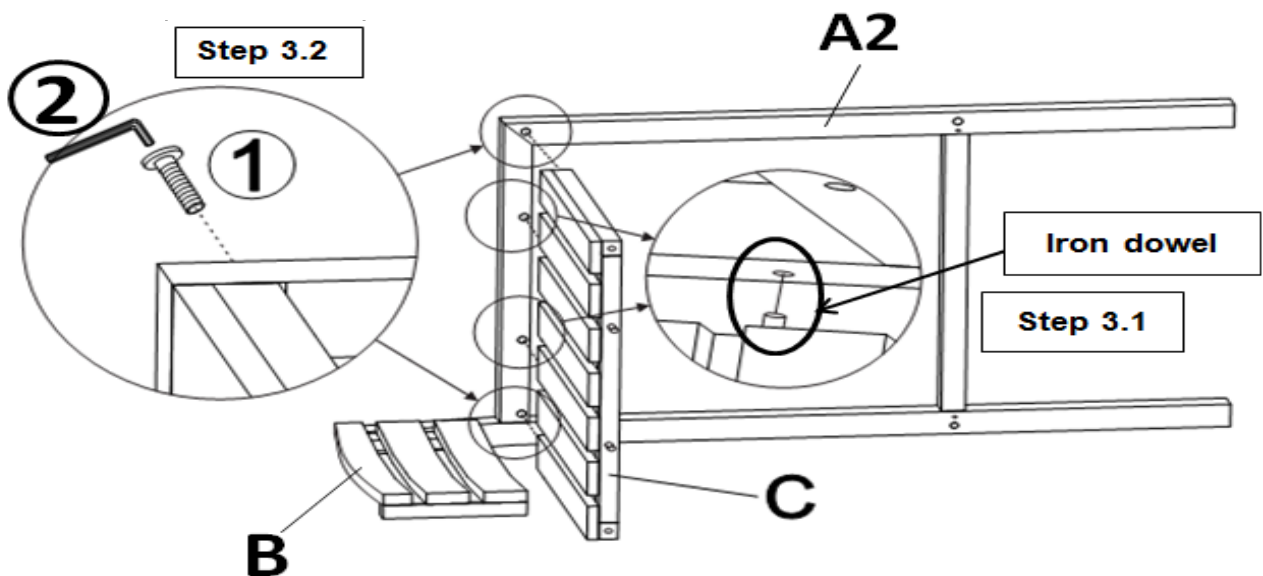

3.1) Insert 2 prefixed iron dowels of Seat Panel (C) into housings of Right Leg Panel (A2).

3.2) Secure Seat Panel (C) to Right Leg Panel (A2) by using 2 Bolts (1) with Allen Key(2).

Do not fully tighten Bolts.

Step 4

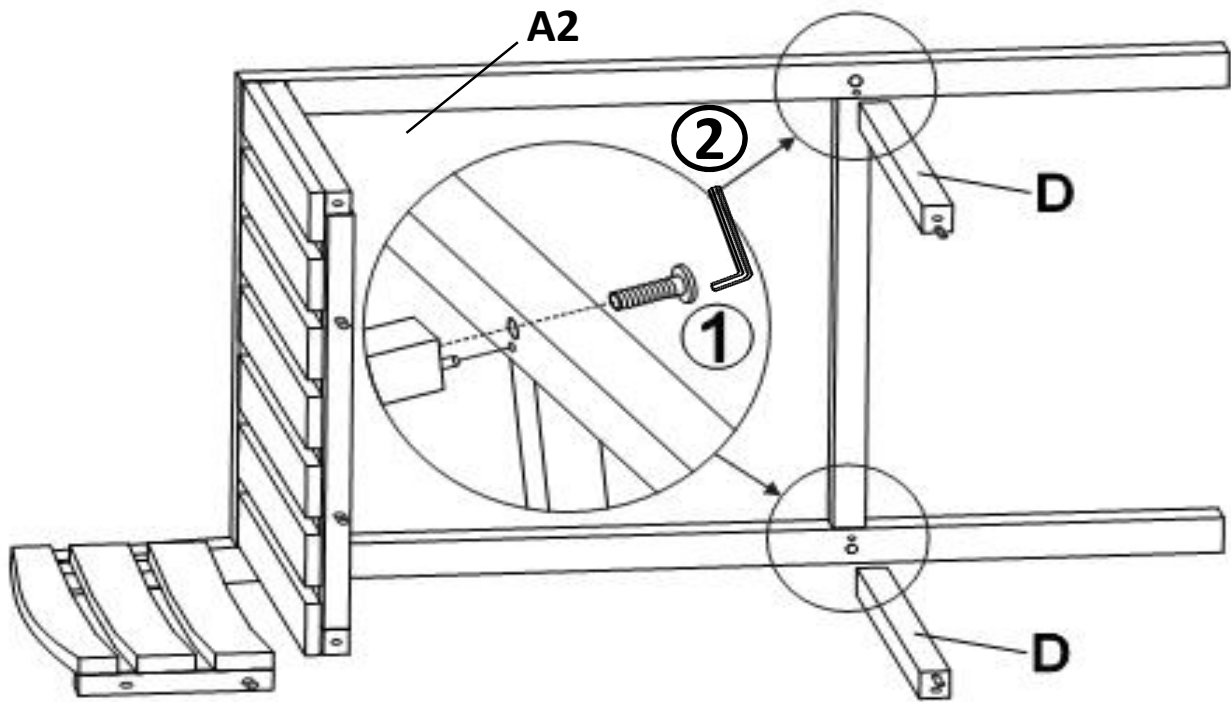

4.1) Insert prefixed iron dowel of Leg Connector (D) into housing of Right Leg Panel (A2).

4.2) Secure Leg Connector (D) to Right Leg Panel (A2) by using Bolt (①) with Allen Key(②).

Do not fully tighten Bolt.

Repeat the same process with the other Leg Connector (D)

Step 5

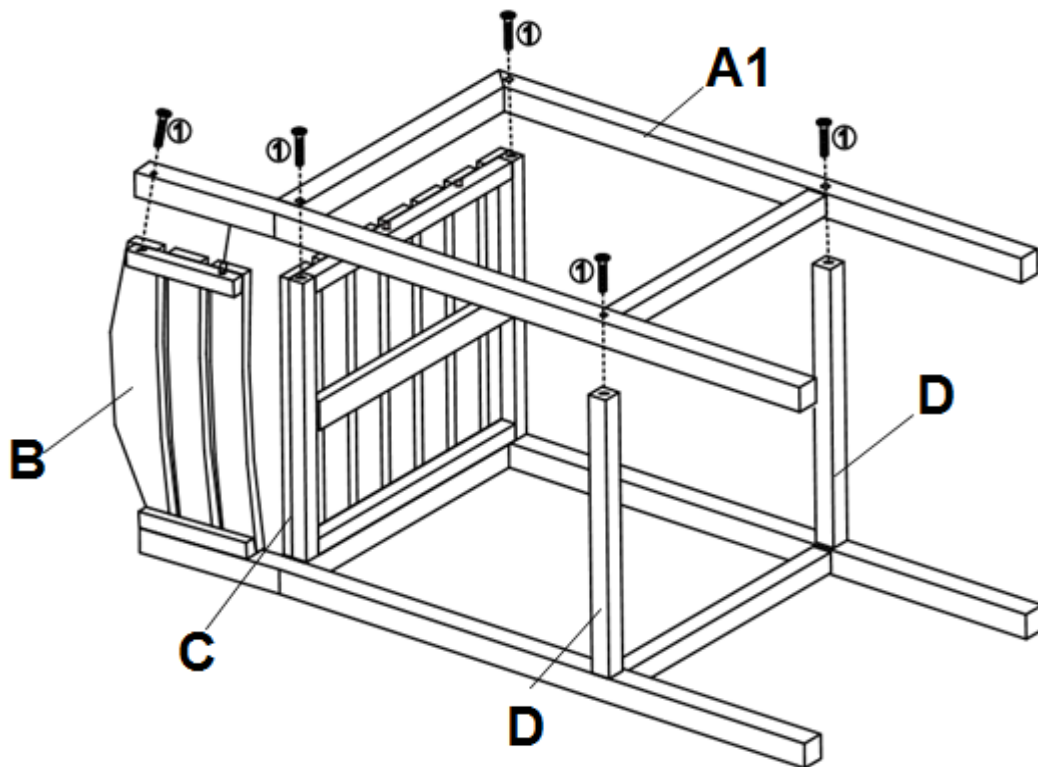

With the assistance of an adult helper, turn the Barstool 90 degree.

Attached Left Leg Panel (A1) to frame in step 4 then secure Left Leg Panel (A1) to Backrest Panel (B) by using long Bolt (②), Seat Panel (C) and Leg Connectores (D) by using Short Bolts (①) and Allen Key (③)

Do not fully tighten Bolts

Step 6

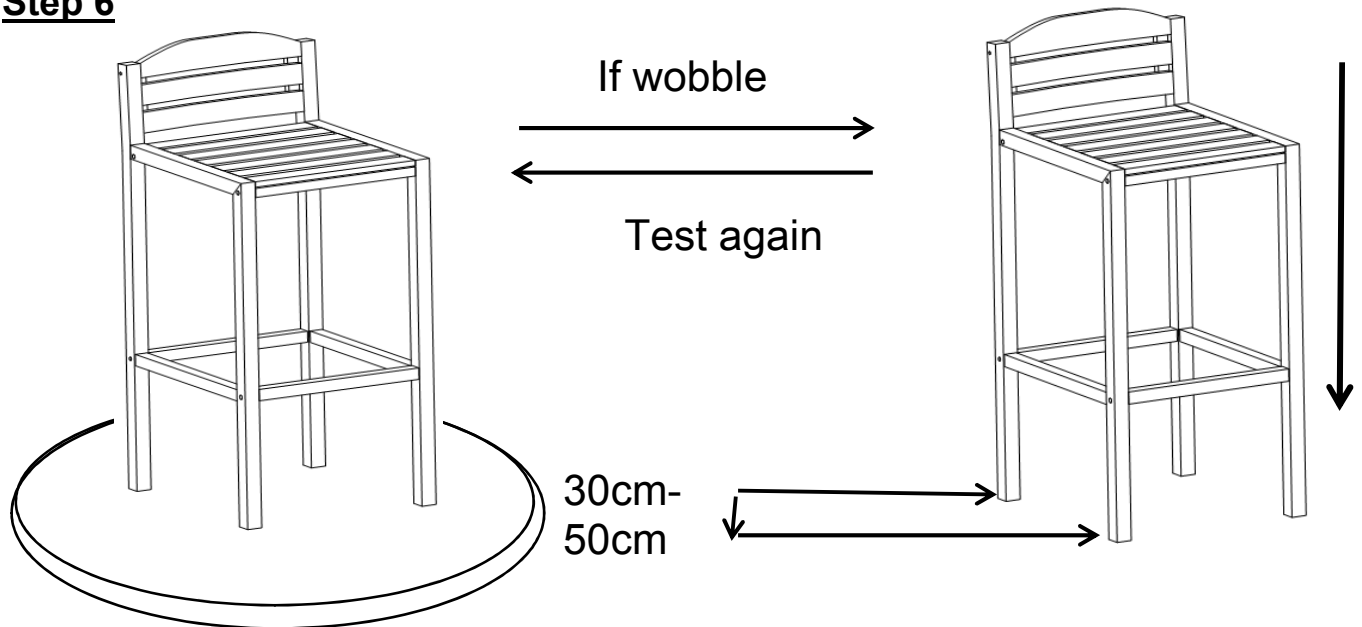

Place the Barstool right side up on a **LEVEL SURFACE** to see if it wobbles.
If it wobbles, lift the Barstool some 30cm to 50cm height from the ground.
Keep your feet and toes well away from the drop zone.

Drop the Barstool freely and vertically with all four legs, hitting the ground at the same time.
This Drop Test will help to ensure that all the Bolts and gaps reach full alignment status.
Test again for evenness on a **LEVEL SURFACE**.
If no wobbles are found, proceed to tighten all the Bolts.

When tightening these bolts, tighten sequentially.

Do not tighten any Bolt fully and then move towards the next one.

This could cause the frame to warp.

If there are still wobbles, loosen the Bolts and execute the same drop tests.

If the Barstool is not stable it could lead to damage to the product.



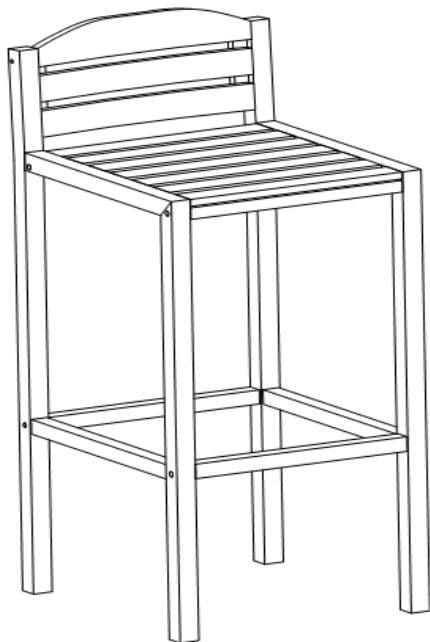





Step 7



Inspect the Barstool and make sure all parts are connected.
Your Barstool is ready for use.

This Barstool can only be used on a flat, level surface.

Care & Maintenance

- ⊘  ● Do not put hot items directly on furniture surface
 - ⊘  ● Do not clean furniture with harsh cleansers or polish.
 - ✓  ● To obtain the longest lifespan of your outdoor products, minimizing exposure to direct sunlight is recommended.
 - ⊘  ● Children should not climb or jump on the furniture.
 - ⊘  ● Do not write on furniture without a padded barrier to protect the surface.
 - ✓  ● To obtain the longest lifespan of your outdoor products, avoid extended and lengthy exposure to rain, snow, and direct sunshine. Whenever possible cover the product and /or place under patio or awnings.
 - ⊘  ● Not for commercial use. For residential use only .
 - ⊘  ● Stains may be removed with mild soap solution and damp cloth.
-
- ✓  ● Dust and pick-up spills using a clean, non-colored, lint-free cloth .