

ASSEMBLY INSTRUCTIONS & PARTS IDENTIFICATION

DARK BROWN

Hardware kit

Ltr	Qty	Description
A	9PCS.	BOLT ØM6X16MM
B	4PCS.	BOLT ØM6X28MM
C	4PCS.	FLAT WASHER
D	1PC	ALLEN WRENCH

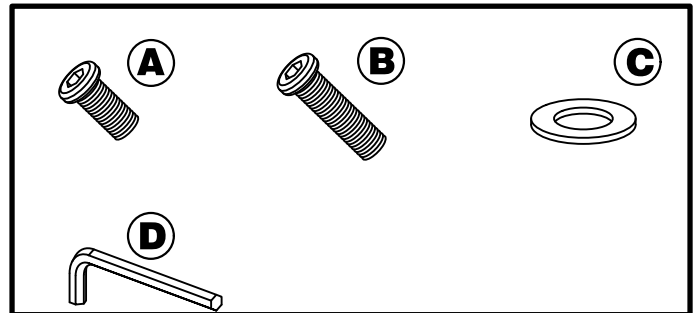

STEP 1:

- . Attach the leg assembly to the seat by inserting a flat washer and short bolt A per the diagram.
- . Attach the back rest frame to the seat by inserting short bolt A per the diagram.
- . Do not fully tighten at this point.

Parts Key

No	Code	Qty	Description
1	a	1PC	LEG ASSEMBLY
2	b	1PC	BACK FRAME
3	v	1PC	BACK CUSHION
4	f	1PC	SEAT CUSHION
5	b	4PCS	LEVELER

STEP 2:

STEP 1:

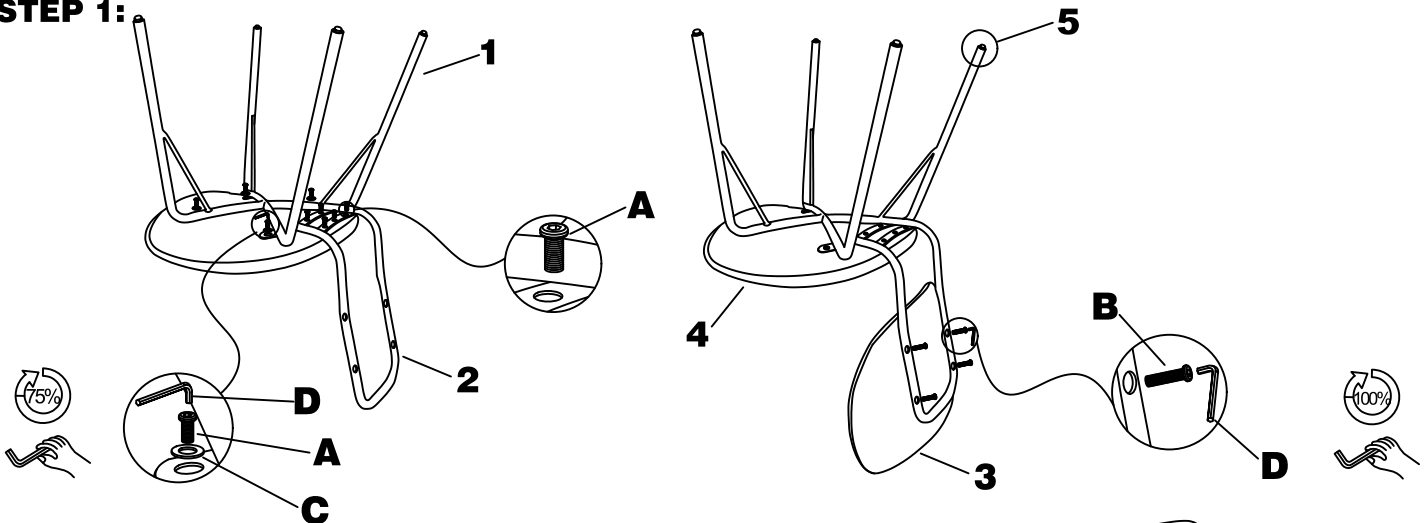

STEP 2:

- . Attach the backrest cushion to the backrest frame by inserting longer bolt B per the diagram.
- . Do not fully tighten the bolts until all are in place.
- . Once all bolts are in place, fully tighten the bolts by hand using the provided Allen Wrench. DO NOT use a power tool to tighten.
- . Use the floor levelers to level the chair, if needed.

*** FABRIC CARE:

Avoid direct sunlight, water, oil, acid, sharp objects etc.
 Use vacuum cleaner to clean. Wipe spills immediately.
 If needed, spot clean with a mild water-based soap.
 Fabric content 100% Polyurethane, Cleaning Code W

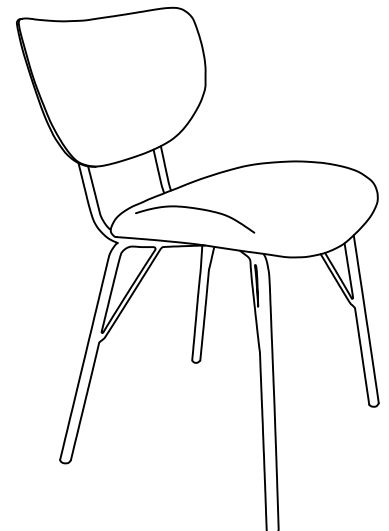







ASSEMBLY INSTRUCTIONS & PARTS IDENTIFICATION

RECLAMATION ROUND DINING TABLE

Thank you for purchasing this quality product. Be sure to check all packing material carefully for small parts that may have come loose inside the carton during shipment.

Parts			
No.	Code	QTY	Description
1	a	1 PC	Table Top
2	b	4 PCS	Leg
3	c	4 PCS	Floor Glides

Hardware Kit			
No.		Description	Qty
A		Flat washer M8x18	20 pcs
B		Lock Washer M8	12 pcs
C		Bolt M8x30	4 pcs
D		Bolt M8 x 45	8 pcs
E		Wrench	1 pc
F		Nut	8 pcs

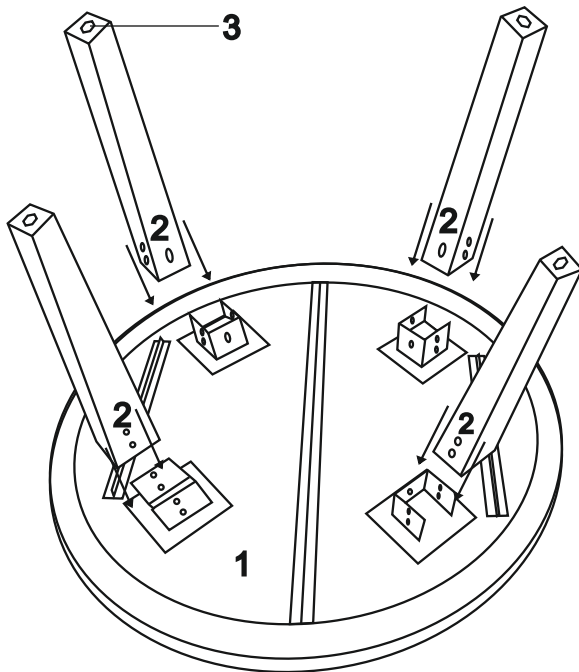

- CAREFULLY LAY TABLE UPSIDE DOWN ON SMOOTH SURFACE TO PREVENT SCRATCHING.
- POSITION THE LEG IN THE BRACKET WITH A BOLT "D" AND A FLAT WASHER. PUT ALL THE BOLTS THROUGH THE LEGS IN EACH POSITION.
- ATTACH THE BOLT USING A FLAT WASHER, LOCK WASHER, AND A NUT. DO NOT FULLY TIGHTEN AT THIS POINT.
- ATTACH BOLT "C" WITH A LOCK WASHER AND A FLAT WASHER TO THE FRONT POSITION OF THE LEG AND TIGHTEN WITH THE WRENCH PROVIDED.
- TIGHTEN ALL NUTS FIRMLY.
- TWO PERSON REQUIRED TO FLIP THE TABLE

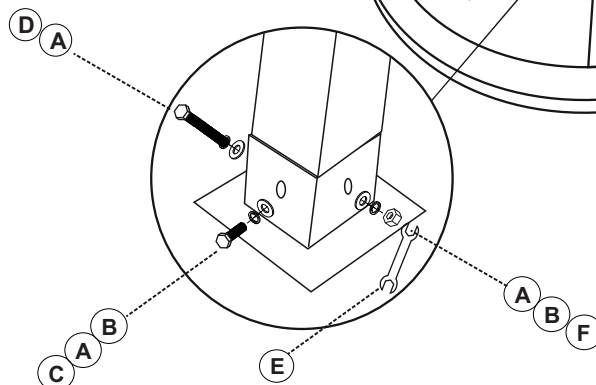
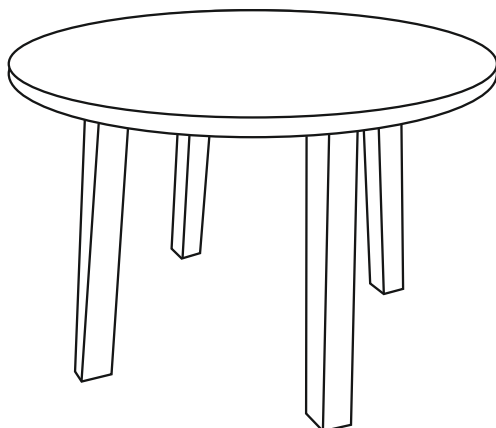
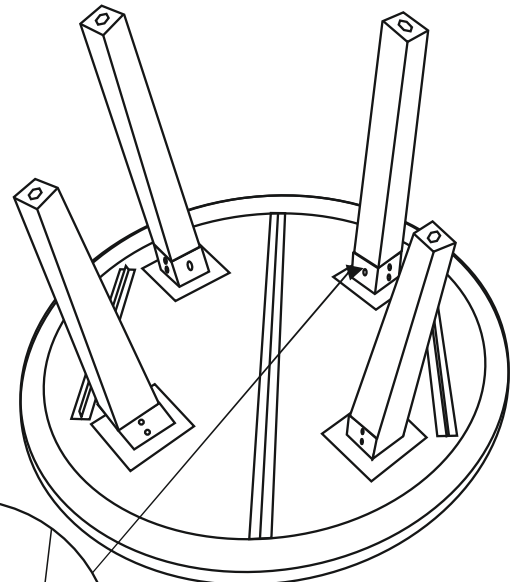

MADE IN INDIA