

Assembly Instructions

Caution: You must read this before you proceed

Please look in the Seat Base Panel for hardware pack

Sun Lounger

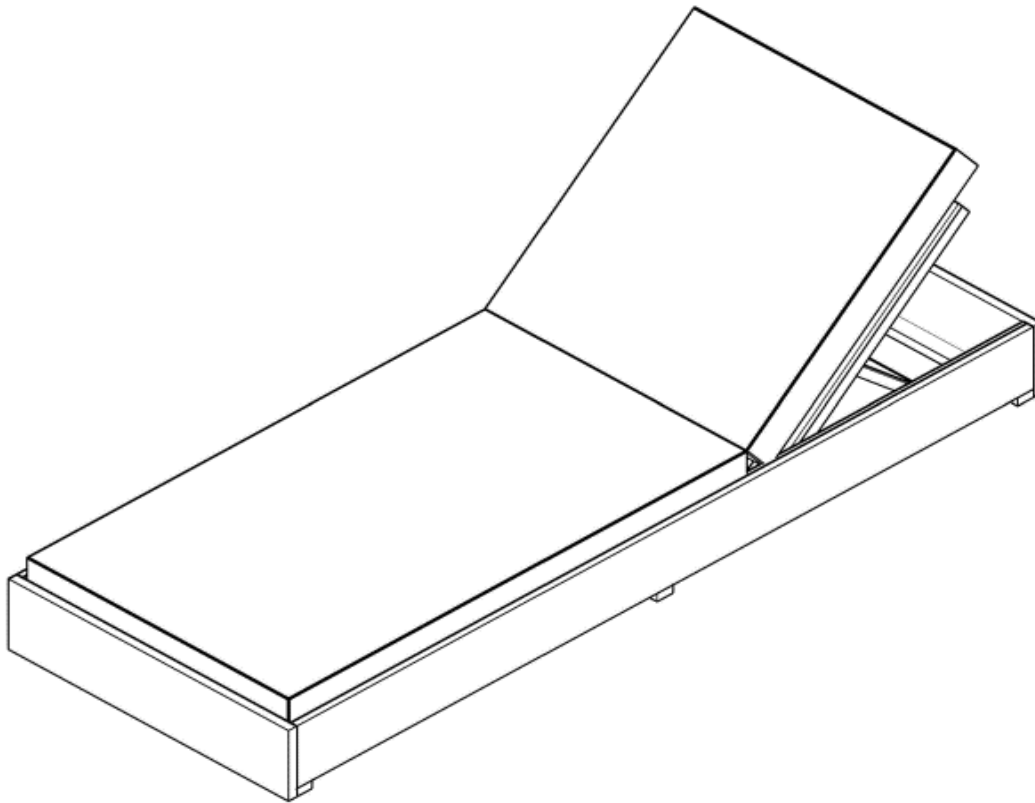









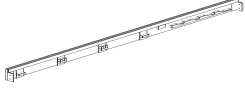

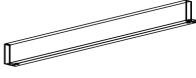

CAUTION: This Sun Lounger is NOT a TOY.

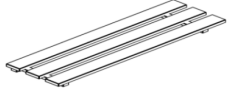

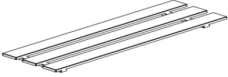

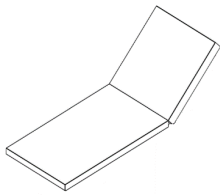

Keep your child / children at bay during the assembly process.

Whenever lifting or moving the Sun Lounger and to prevent damage to the Sun Lounger, two adults may be needed to execute these actions.

Parts List

Label	Picture	Description	QTY
A		Left Seat Base Panel	1
B		Right Seat Base Panel	1
C		First Support Bar	2
D		Second Support Bar	2
E		Seat Base Panel	2
F		Feet Base Panel	1
G		Seat Frame	3
H		Left Backrest Frame	1
I		Right Backrest Frame	1
J		Middle Backrest frame	1
K		Horizion Bar	1
L		Verticle Bar	2
M		Lower Backrest Panel	1
N		Upper Backrest Panel	1
O		Cushion	1

Hardware

Label	Picture	Description	QTY
①		Screw (M6 X 30 mm)	7
②		Screw (M6 X 40 mm)	11
③		Bolt (M6 X 20 mm)	9
④		Bolt (M6 X 45 mm)	3
⑤		Flat Washer (Ø6/20 X 4 mm)	5
⑥		Allen Key	2
⑦		Flat Washer (Ø6/14 X 1 mm)	9

Assembly Preparation

Before Beginning Assembly:

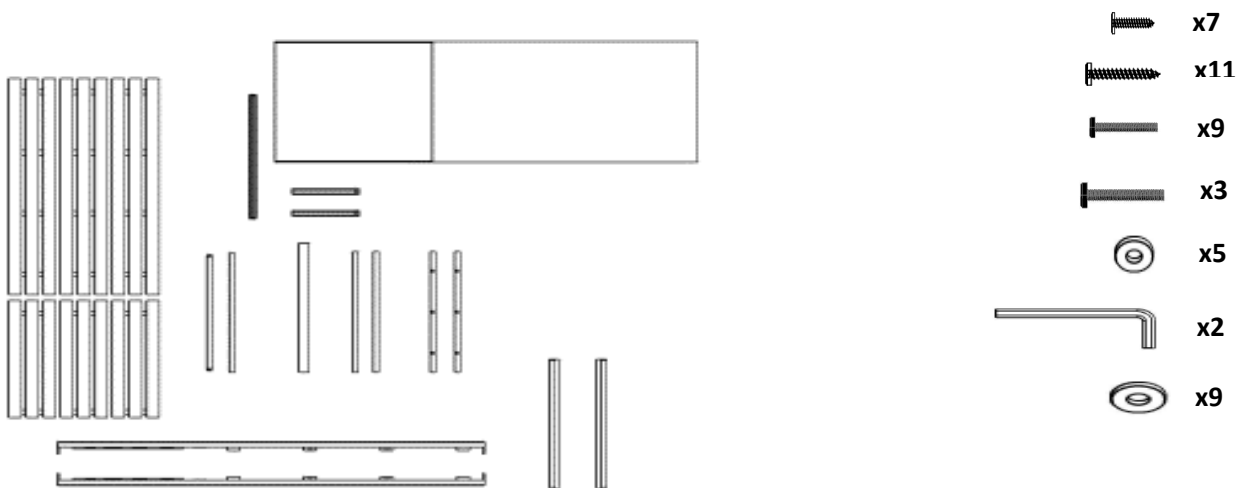

- Read instructions, cover to cover-



- Have 2 adults on hand for assembly-



- Do not assemble on flooring or carpet-



- Assemble on a clean non-marring surface (packing foam)-



- Save all packaging until finished-

Assembly Steps

Overview

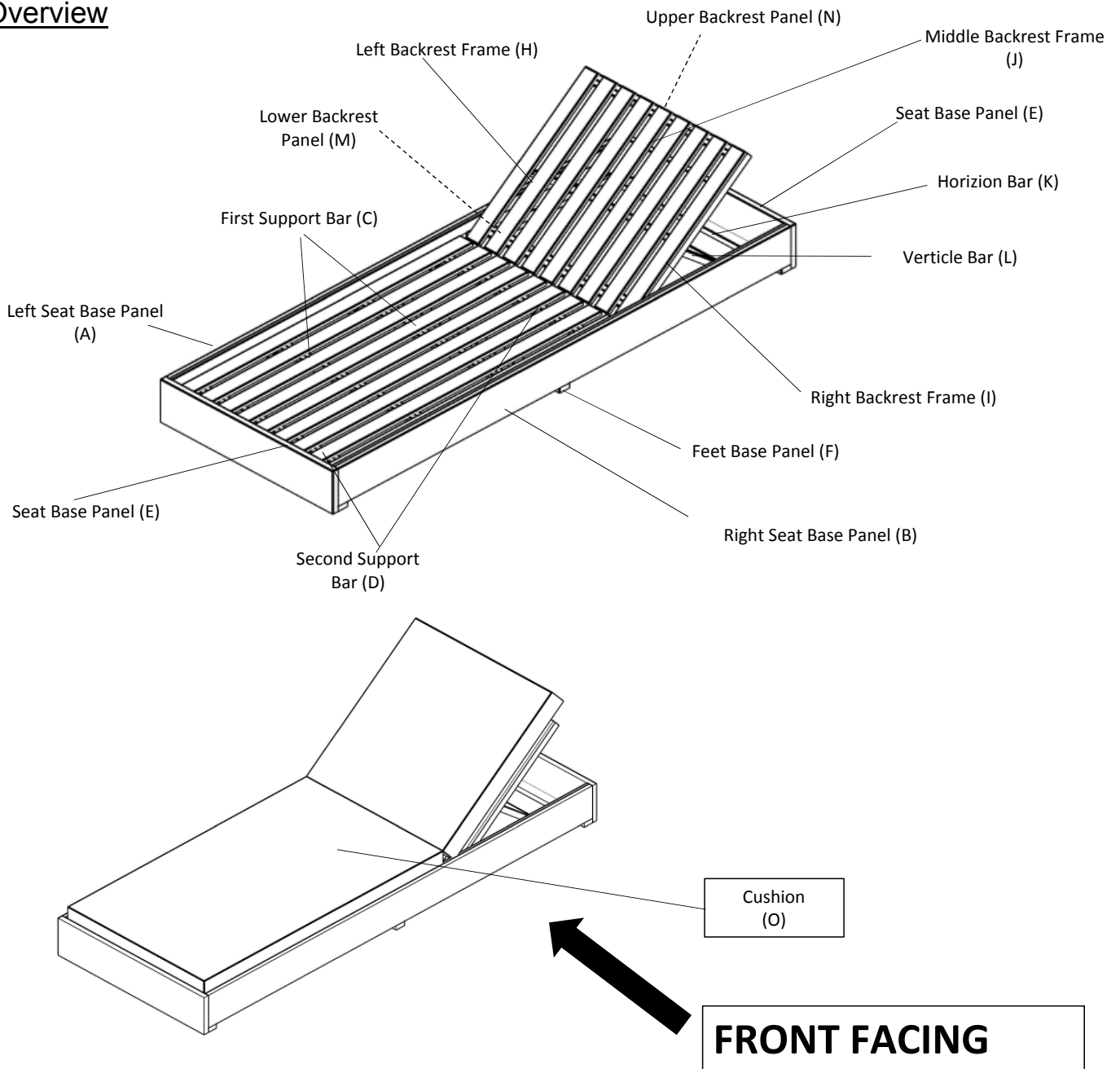

This Sun Lounger has multiple parts and may require up to 60 minutes to assemble. To give you an overview of the Sun Lounger, the above picture is to help you put the various parts into perspective. Please read through the instructions below to familiarise yourself with the parts and steps before assembly.

Step 1

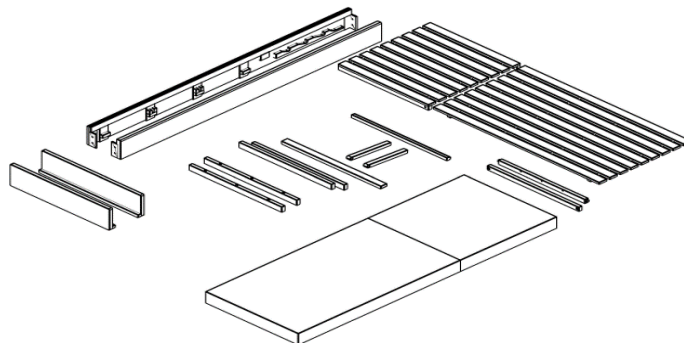

Unpack and place all parts on a clean, non-marring surface.

Step 2

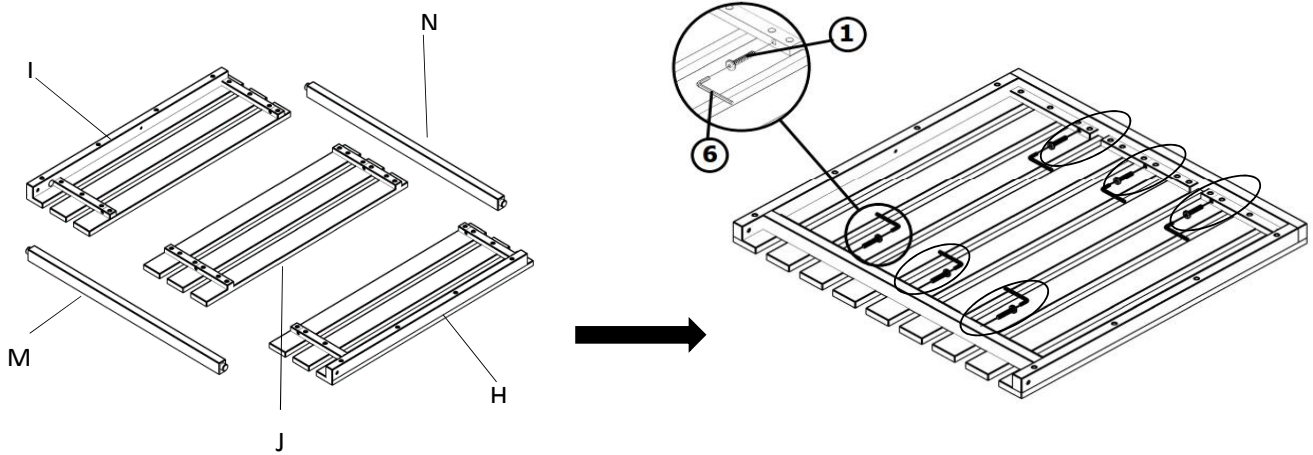

Place Right Backrest Frame (I), Middle Backrest frame (J), Left Backrest Frame (H) on a clean, non-marring surface

Then attach Upper Backrest Panel (N), Lower Backrest Panel (M) to Right Backrest Frame (I), Middle Backrest frame (J), Left Backrest Frame (H) using Screw (1) and Allen Key(6) as shown above

Do not fully tighten the Screws.

Step 3

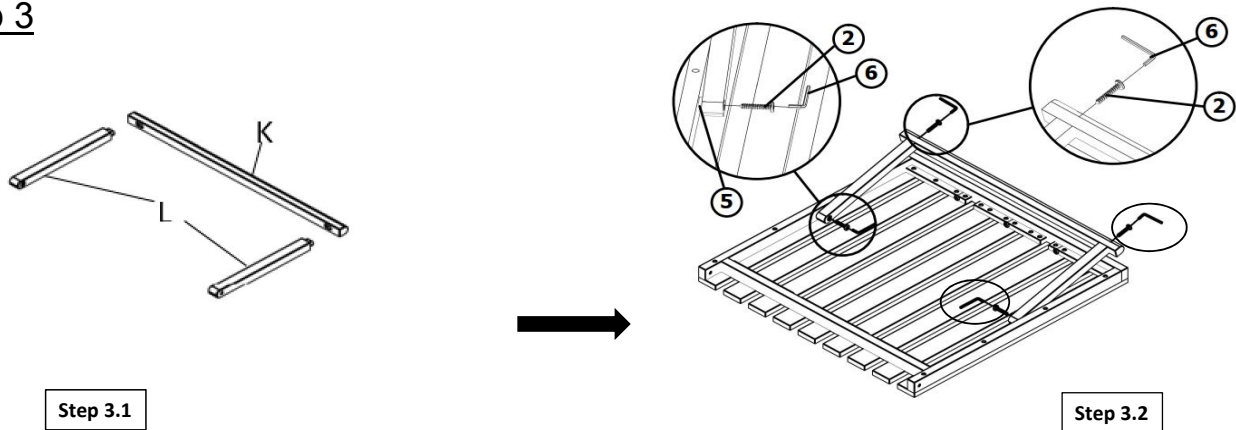

3.1) Position the tenon of Verticle Bar (L) to the housing of Horizion Bar (K) as shown above

3.2) Attach the assembled part in step 3.1 to assembled part in step 2 using Screw (2), Flat Washer (5) and Allen Key(6) as shown above

Do not fully tighten the Screws

Step 4

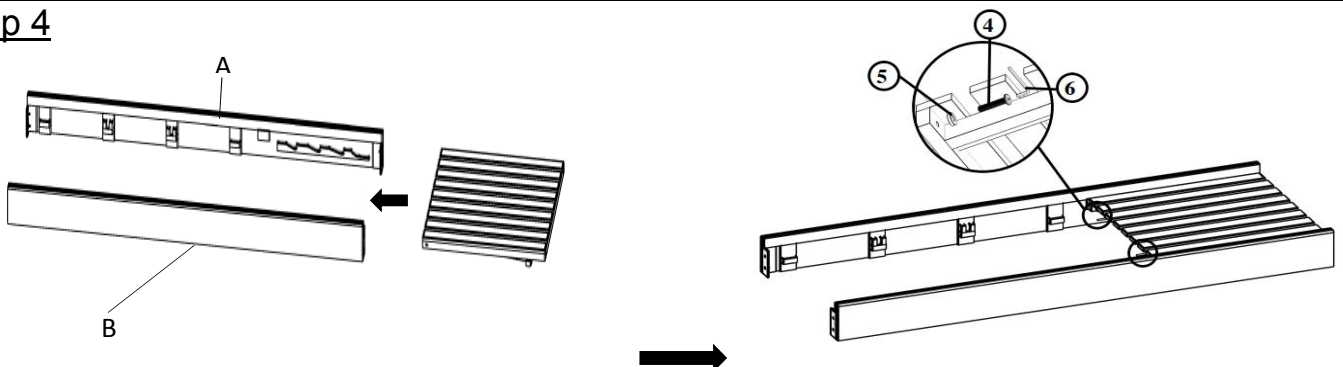

Position the assembled part in step 3 into Left Seat Base Panel (A) and Right Seat Base Panel (B) using Bolt (3), Flat Washer (5), Allen key (6) as shown above

Do not fully tighten the Bolts

Step 5:

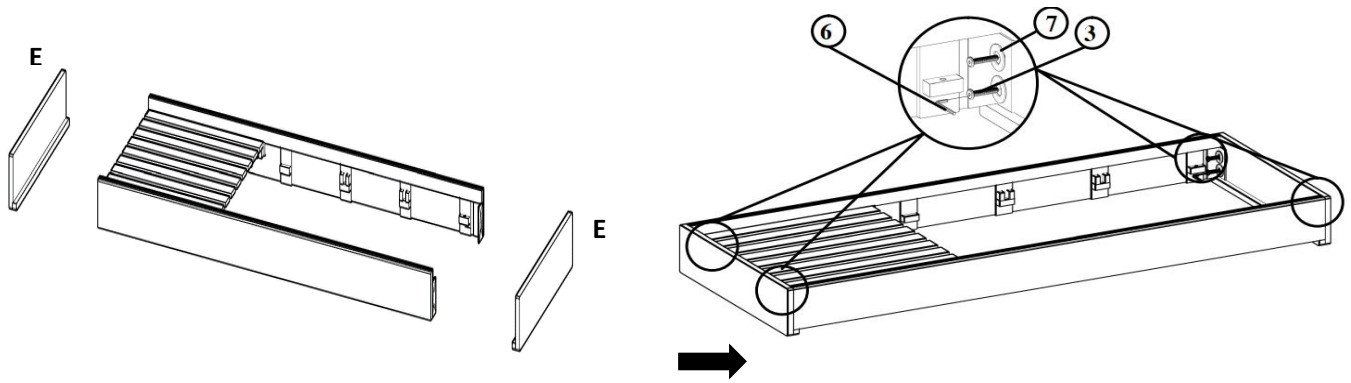

Attach the Seat Base Panel (E) to assembled part in step 4 using Bolt (③), Flat Washer (⑦) and Allen Key (⑥) as shown above

Do not fully tighten the Bolts

Step 6:

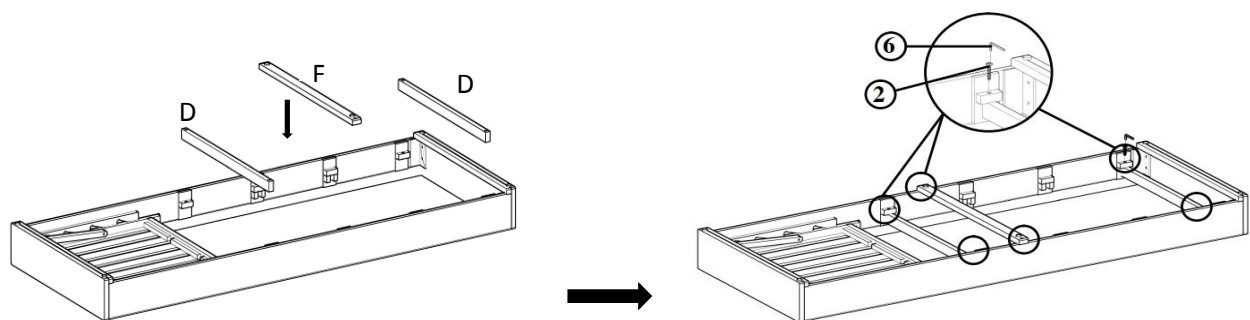

With the help of your adult partner, flip the assembled part in step 5, then attach Second Support Bar (D), Feet Base Panel (F) using Screw (②) and Allen Key (⑥) as shown above

Do not fully tighten the Screws

Step 7:

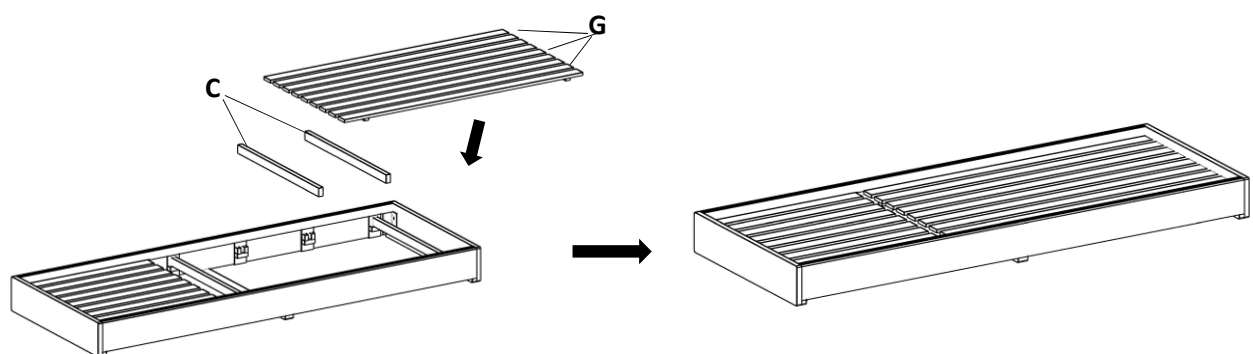

With the help of your adult partner, flip the assembled part in step 6, then attach First Support Bar (C), Seat Frame (G) to assembled part in step 6 as shown above

Step 8:

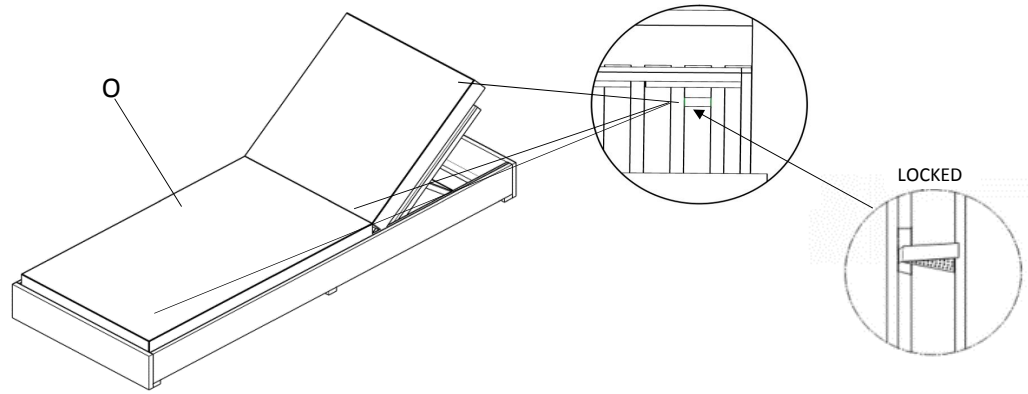

Place the Cushion (O) onto the Sun Lounger and stick the velcro as shown above.

Place the Sun Lounger on a LEVEL SURFACE.

Inspect it and make sure all parts are adequately connected.

Gently and gracefully, sit onto the Sun Lounger.

This will help align all the parts at all joint areas.

Then get off the Sun Lounger and proceed to tighten the Bolts in a sequential manner.

When tightening the Bolts tighten sequentially.

DO NOT tighten any Bolt and Screw fully and then move on towards the next one.

If there are any wobbles after tightening, loosen the Bolts/Screws and execute this same process.

The Sun Lounger is ready to be used.

This Sun Lounger can only be used on a flat, level surface.

Care & Maintenance

- ⊗ ☕ ● Do not put hot items directly on furniture surface.
- ⊗ 🧴 ● Do not clean furniture with harsh cleansers or polish.
- ✓ ☀ ● To obtain the longest lifespan of your outdoor products, minimizing exposure to direct sunlight is recommended.
- ⊗ 🧒 ● Children should not climb or jump on the furniture.
- ⊗ ✍ ● Do not write on furniture without a padded barrier to protect the surface.
- ✓ ☁ ● To obtain the longest lifespan of your outdoor products, avoid extended and lengthy exposure to rain, snow, and direct sunshine. Whenever possible cover the product and /or place under patio or awnings.
- ⊗ 🏢 ● Not for commercial use. For residential use only.
- ⊗ 🧴 ● Stains may be removed with mild soap solution and damp cloth.
- ✓ 🧺 ● Dust and pick-up spills using a clean, non-colored, lint-free cloth .