

# STEP 18

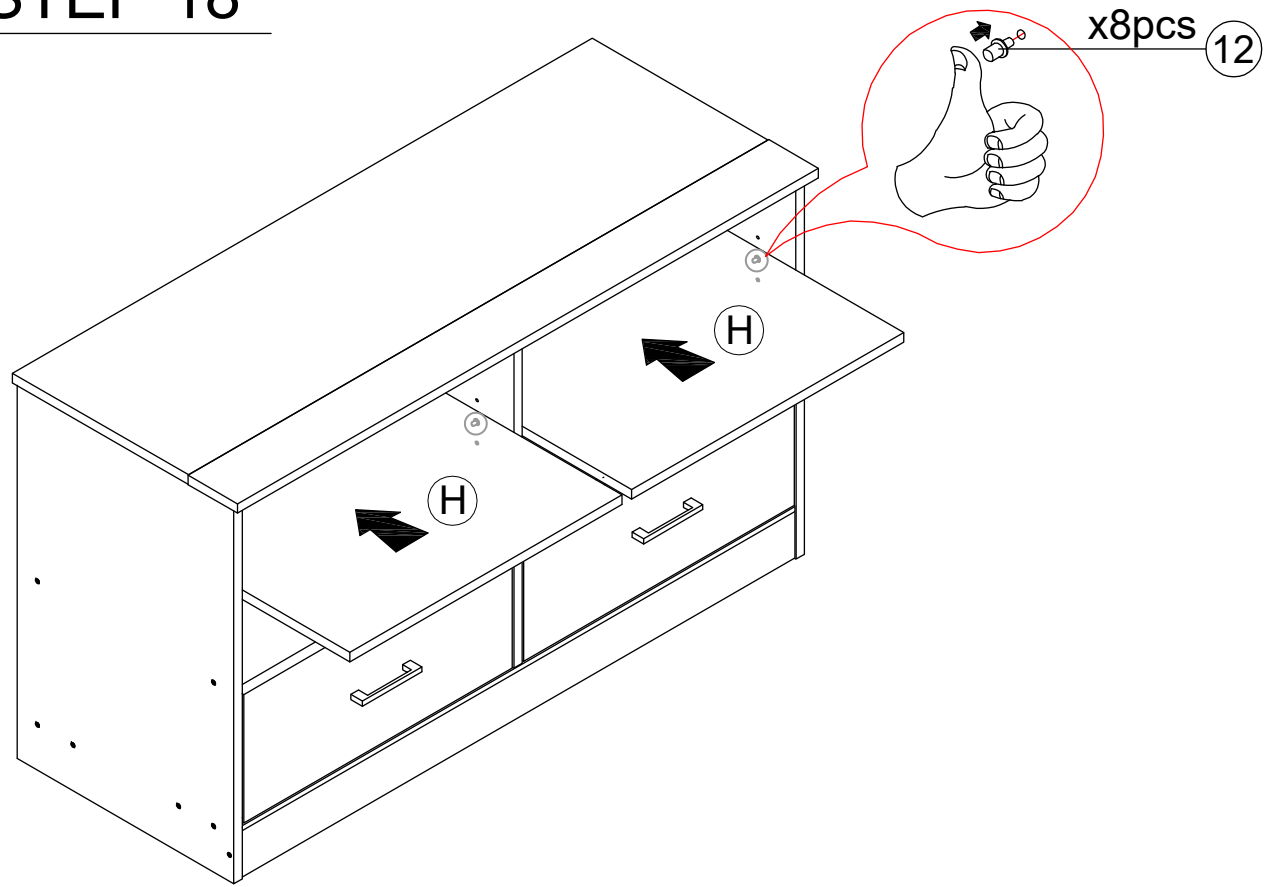

## Recommended Maximum Weight

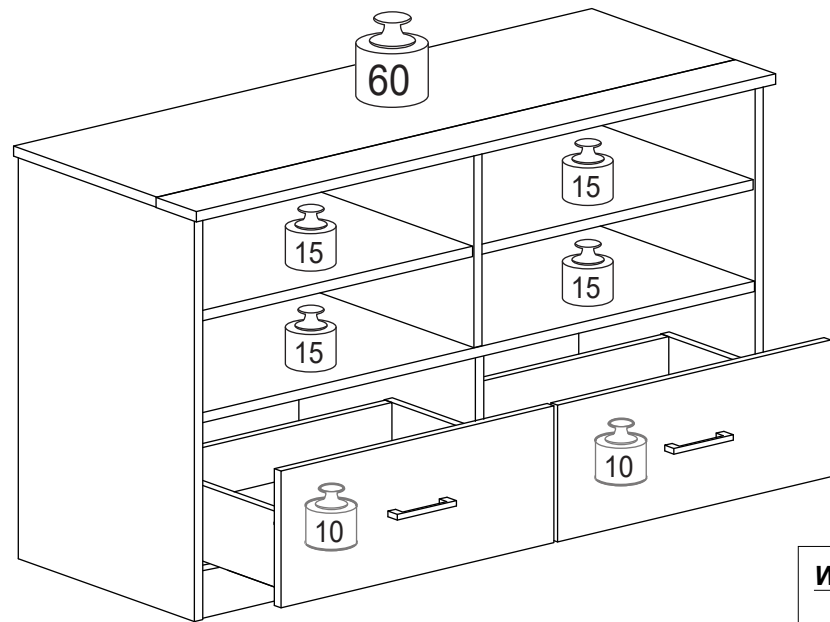

\*Unit in Pound(lbs.)

**WARNING:**

>This unit has been designed to support the maximum loads shown. Exceeding these load limits could cause sagging, instability, product collapse, and/or serious injury.

>DO NOT allow children to climb on unit.

> Put heavier items on lower shelves.

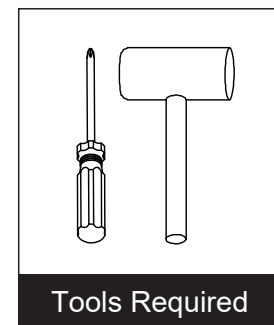
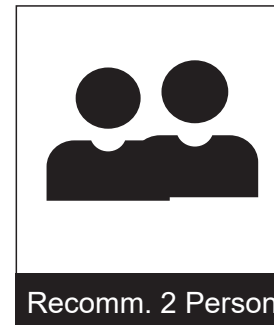
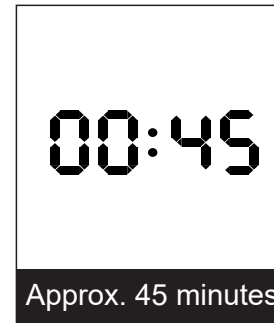

### Assembly Instruction

Furinno Jensen TV Stand with Drawer

MODEL : 20202

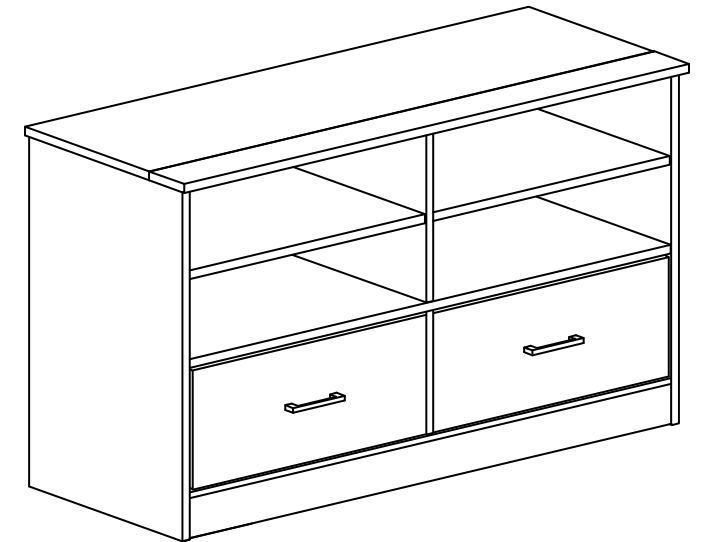















### Customer Support

**NEED HELP?** For replacement requests or product inquiries, please contact our Customer Service Team by emailing us at [support@furinno.com](mailto:support@furinno.com). Thank you for selecting Furinno!

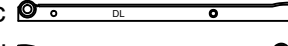
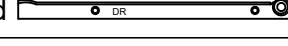
[www.furinno.com](http://www.furinno.com)



# HARDWARE & PARTS LIST

NO	HARDWARE LIST	QTY	NO	PART LIST	QTY
1	MINIFIX  	12pcs	A	TOP PANEL	1pc
2	CHIPBOARD SCREW 	20pcs	B	TOP SUPPORT PANEL	1pc
3	PWA SCREW 	20pcs	C	RIGHT SIDE PANEL	1pc
4	L BRACKET 	2pcs	D	LEFT SIDE PANEL	1pc
5	DRAWER BRACKET 	4pcs	E	UPPER CENTER PANEL	1pc
6	DRAWER SLIDE 6a  6b  6c  6d 	2sets	F	LOWER CENTER PANEL	1pc
7	SCREW 	24pcs	G	CENTER PANEL	1pc
8	DRIVE FASTENER 	8pcs	H	SHELF PANEL	2pcs
9	HANDLE 	2pcs	I	SUPPORT PANEL 1	1pc
10	HANDLE SCREW 	4pcs	J	SUPPORT PANEL 2	1pc
11	POWER PIN 	28pcs	K	KICK PANEL	1pc
12	SHELF SUPPORT 	8pcs	L	LEG SUPPORT PANEL	1pc
			M	DRAWER FRONT	2pcs
			N	DRAWER SIDE PANEL	4pcs
			O	DRAWER BACK PANEL	2pcs
			P	DRAWER BASE PANEL	2pcs
			Q	BACK PANEL	1pc

## USEFUL HINTS BEFORE YOU START:

1. Read each step carefully before starting.
2. It is important that each step is performed in correct order to avoid difficulties.
3. Identify, sort and count the parts before assembly.
4. Assemble your furniture on packaging cardboard to prevent scratch or damage.
5. Clean the product with mild cleanser using soft dampened cloth. Do not use harsh or abrasive cleanser.
6. Using incompatible hardware might cause damage to product.

## STEP 16

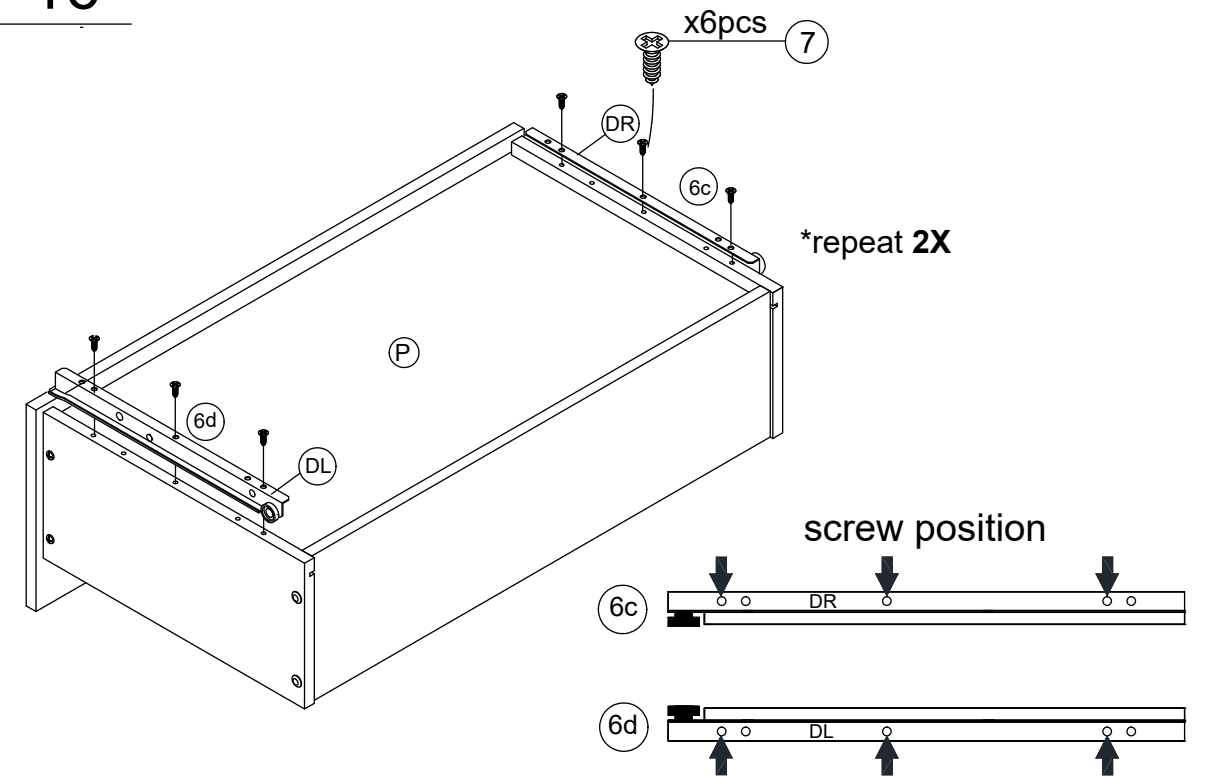

## STEP 17

Note: The drawer bracket holes are sloteed Drawer fronts can be adjusted by loosening screws, making needed adjustments and retightening screws.

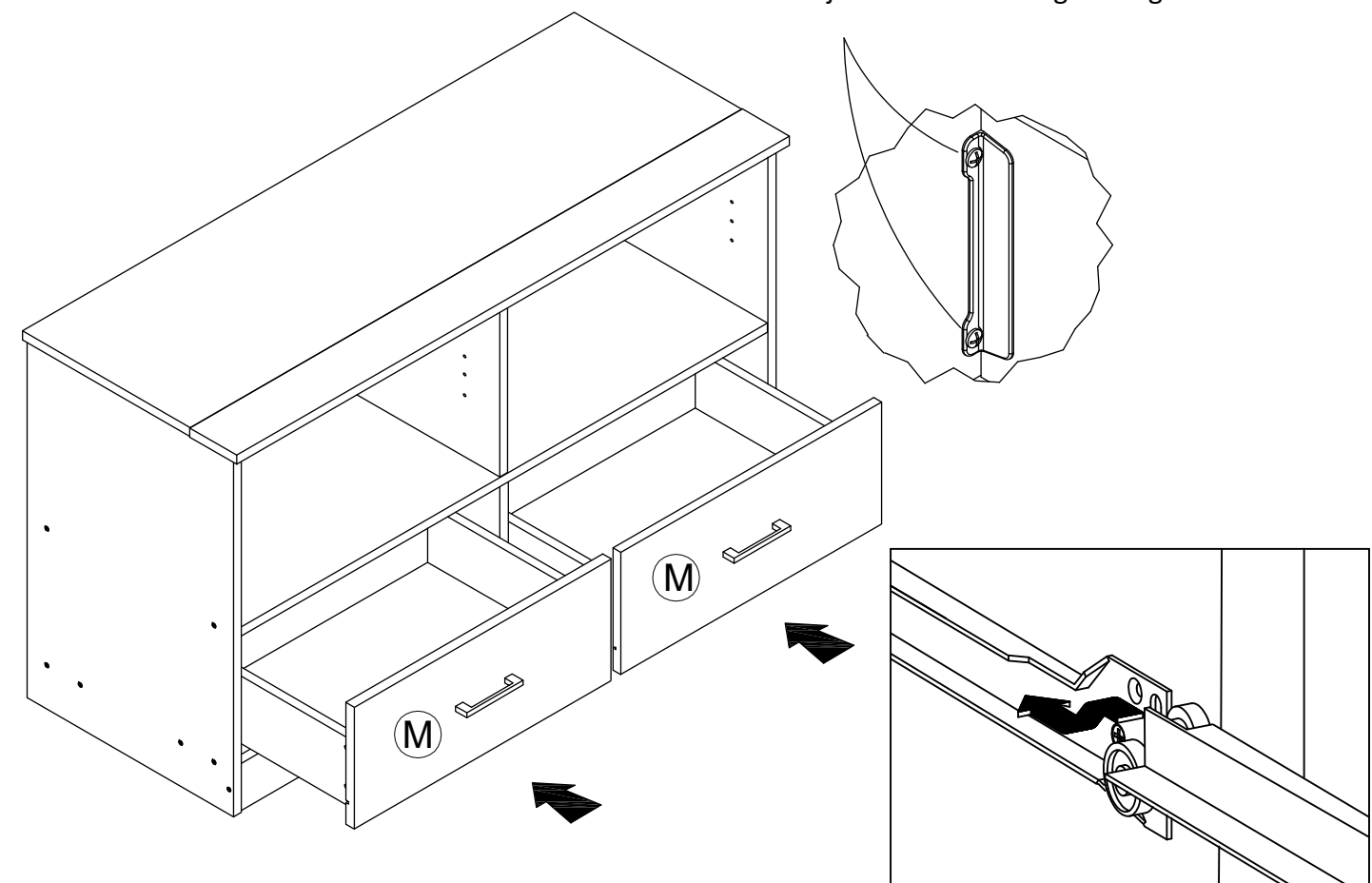

### STEP 13

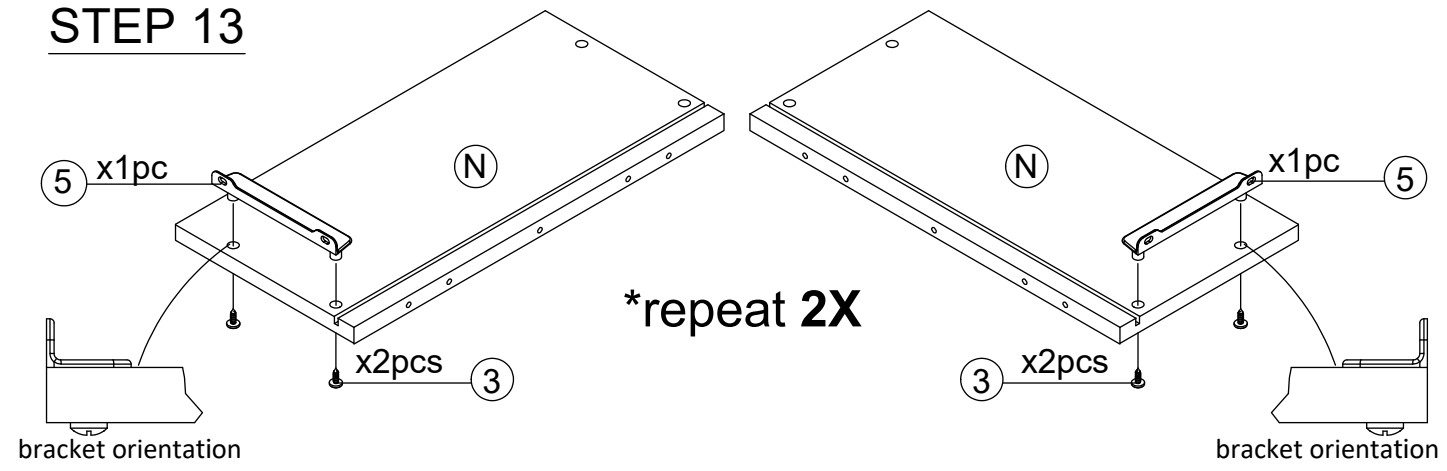

### STEP 14

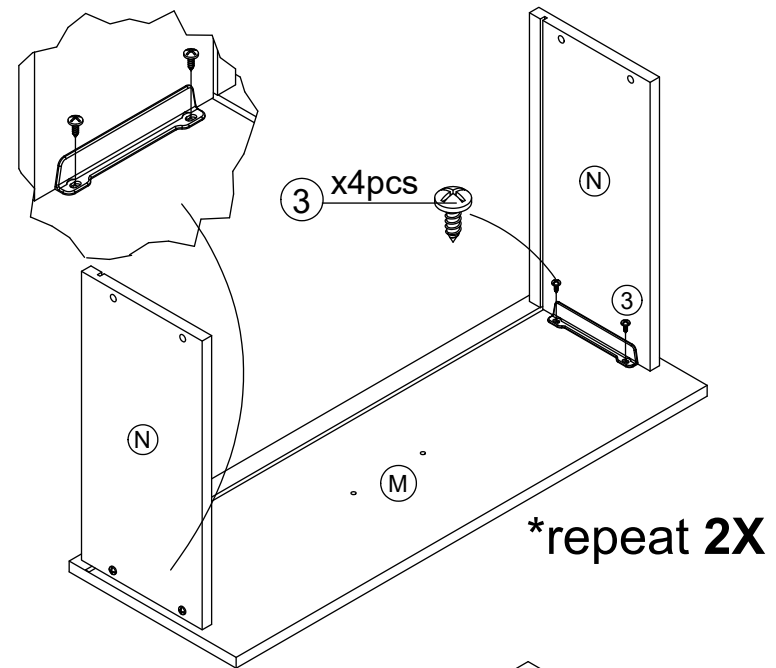

### STEP 15

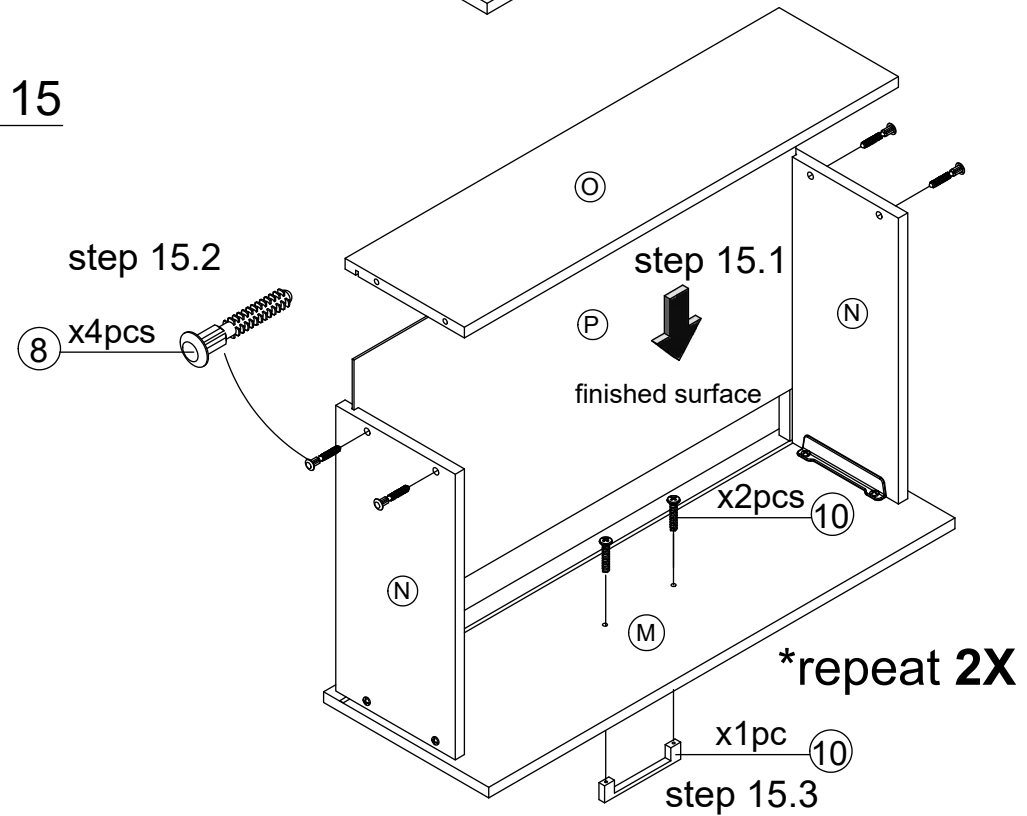

### FRONT VIEW

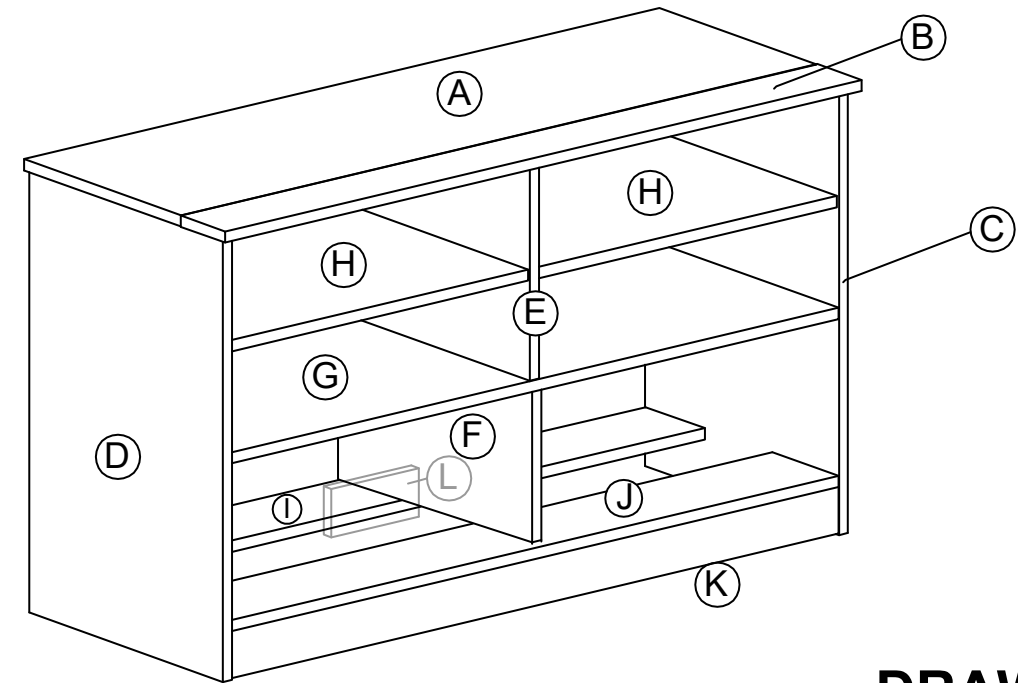

### DRAWER VIEW

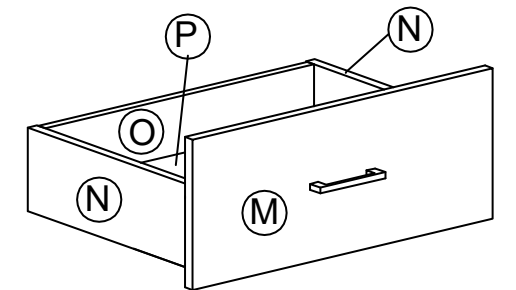

### BACK VIEW

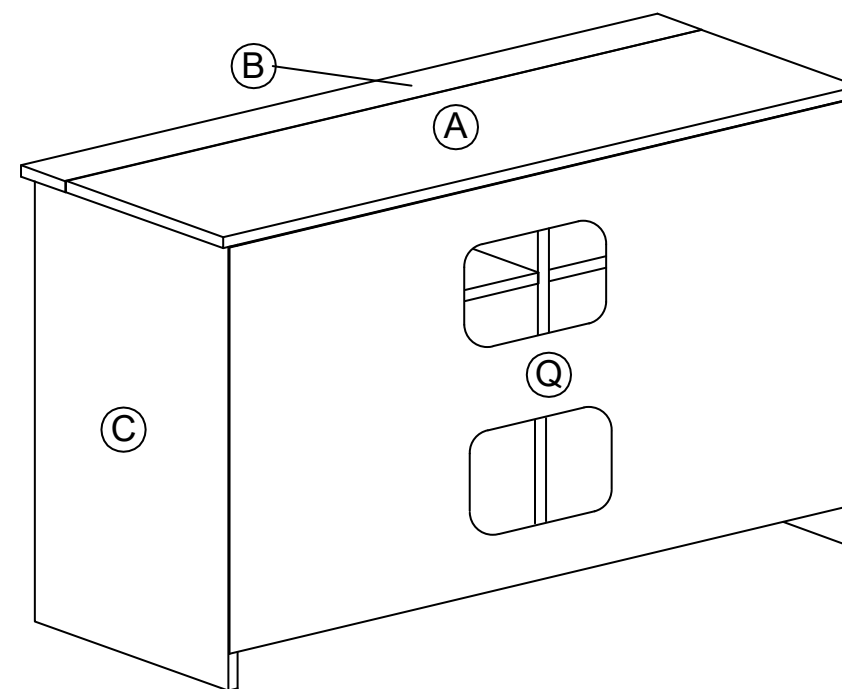

# ASSEMBLY INSTRUCTIONS

BEFORE YOU BEGIN, PLEASE READ ASSEMBLY INSTRUCTIONS CAREFULLY,  
FOLLOW THEM STEP BY STEP.

## STEP 1

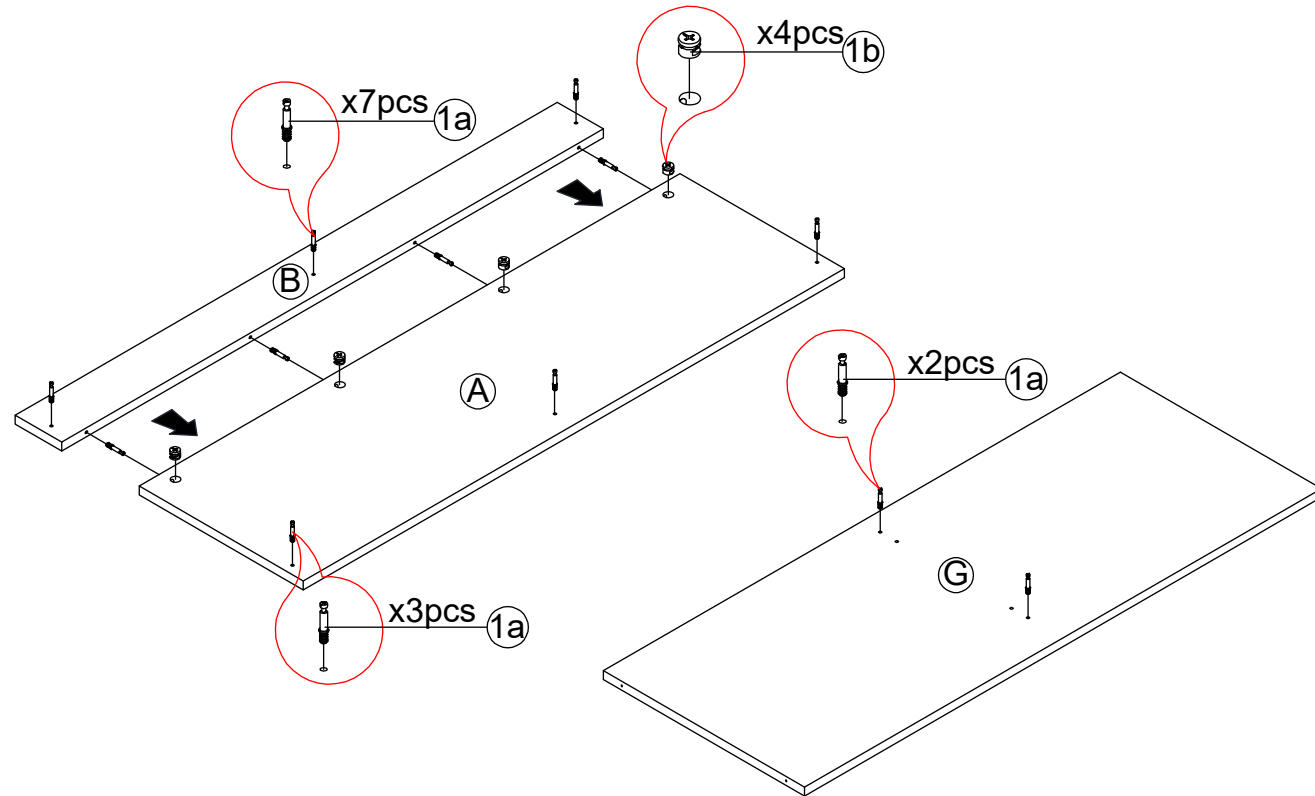

## STEP 2

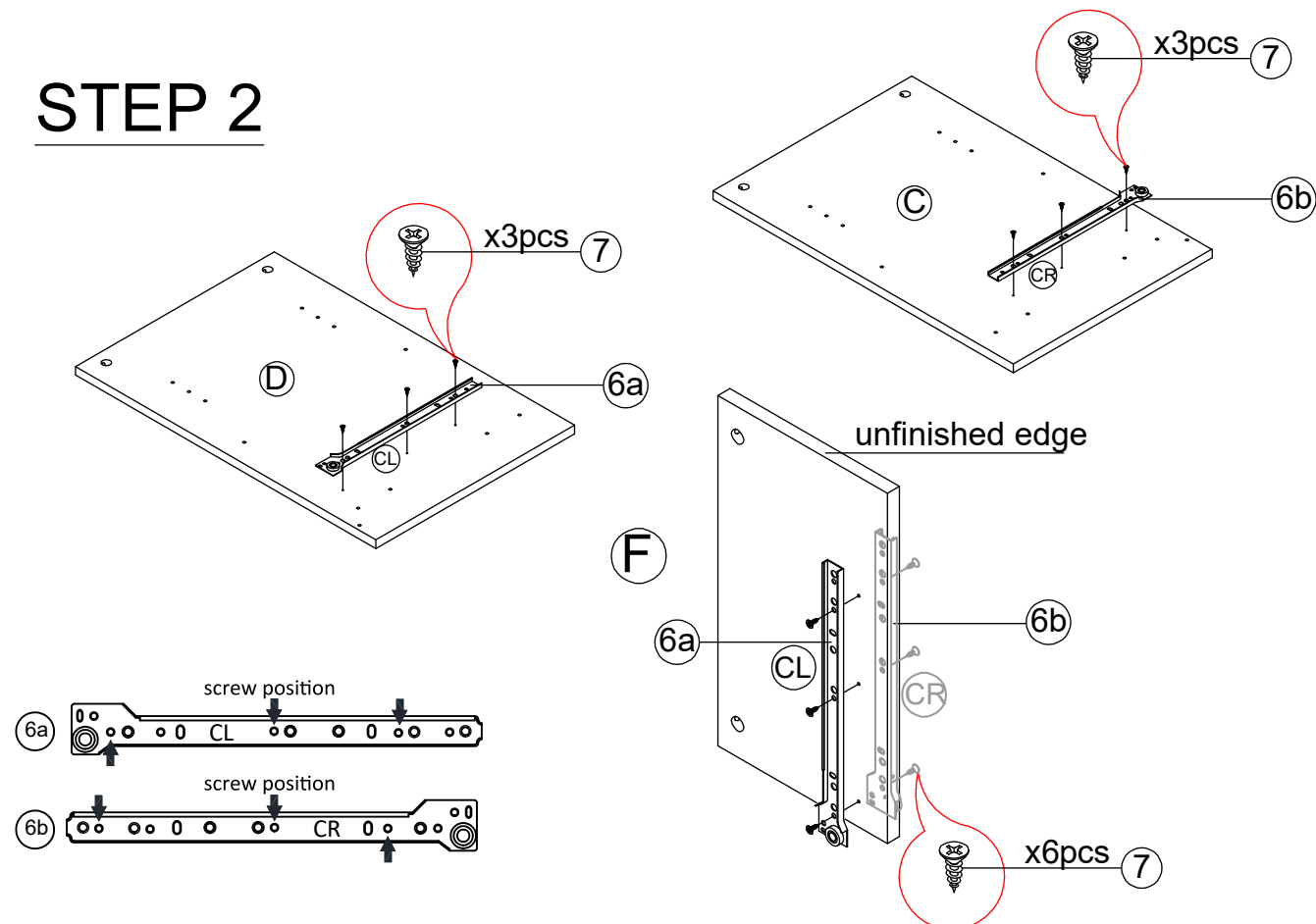

## STEP 11

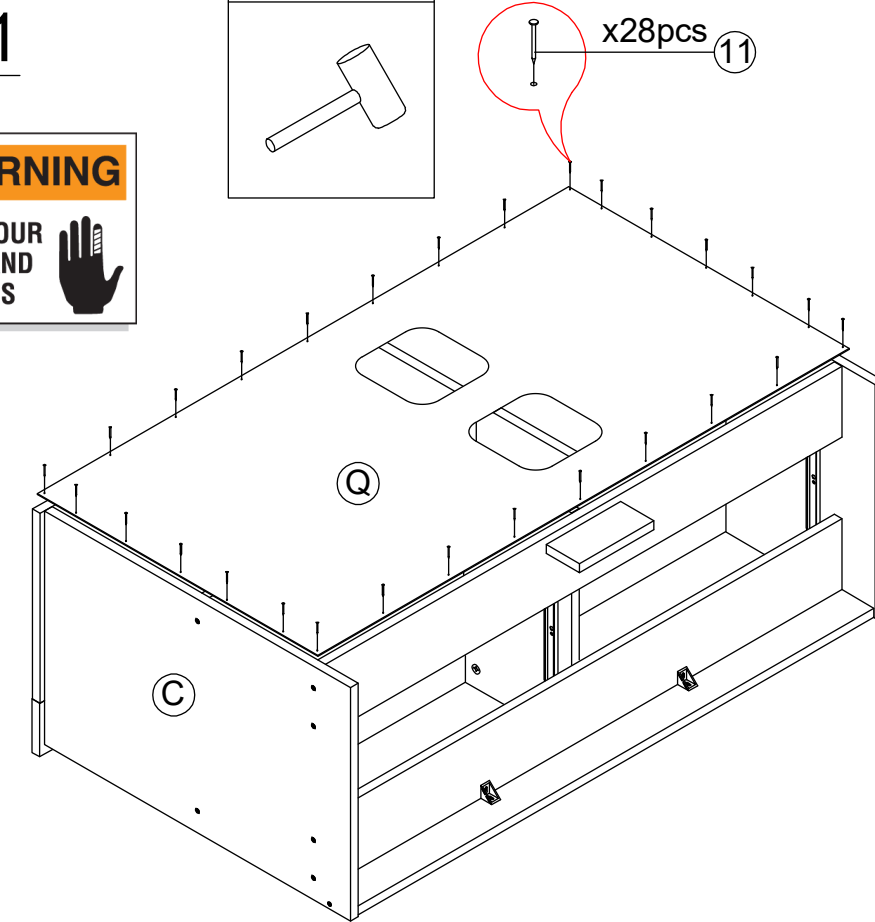
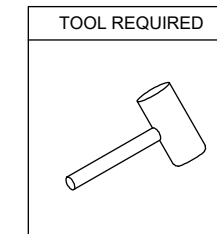

## STEP 12

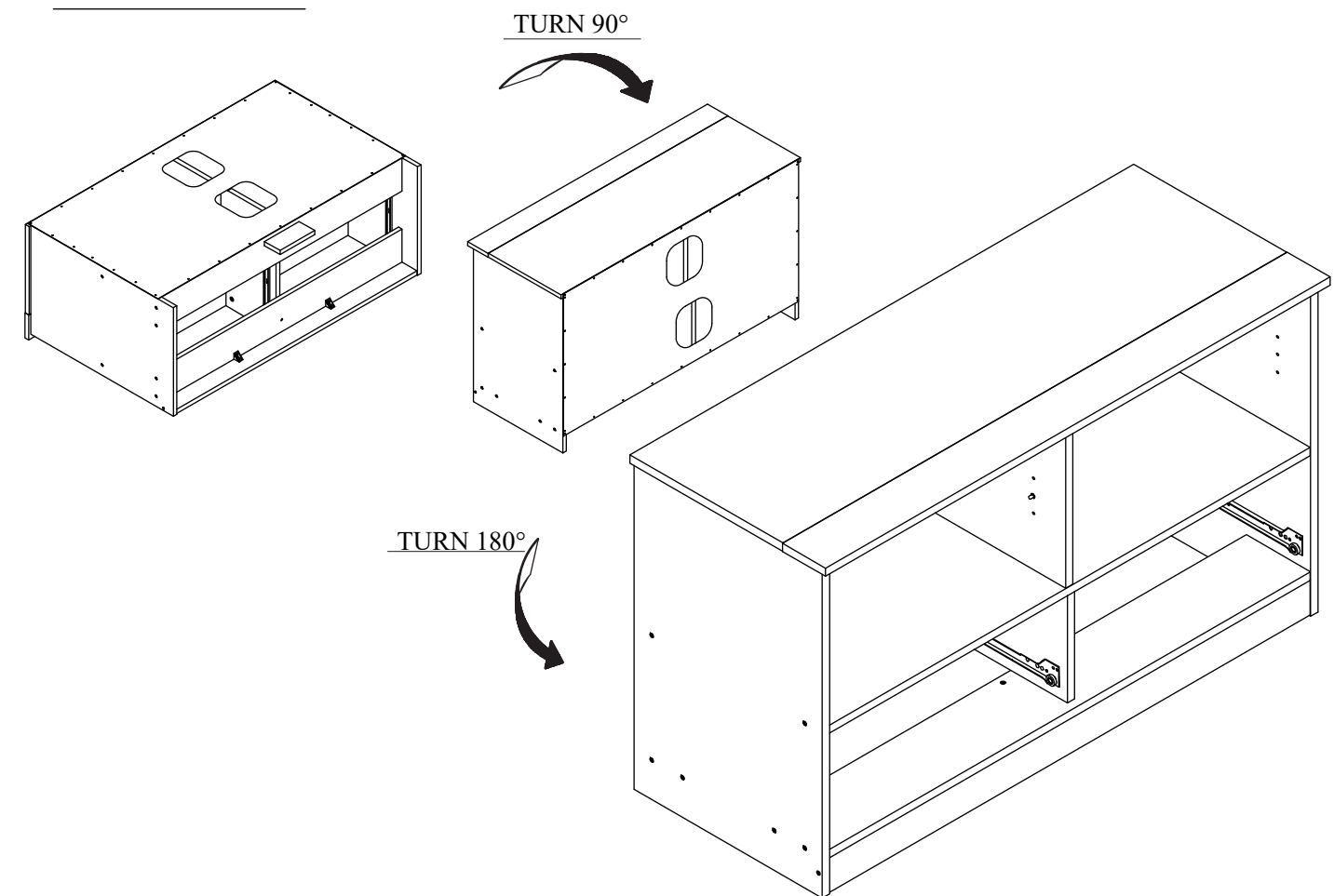

# STEP 9

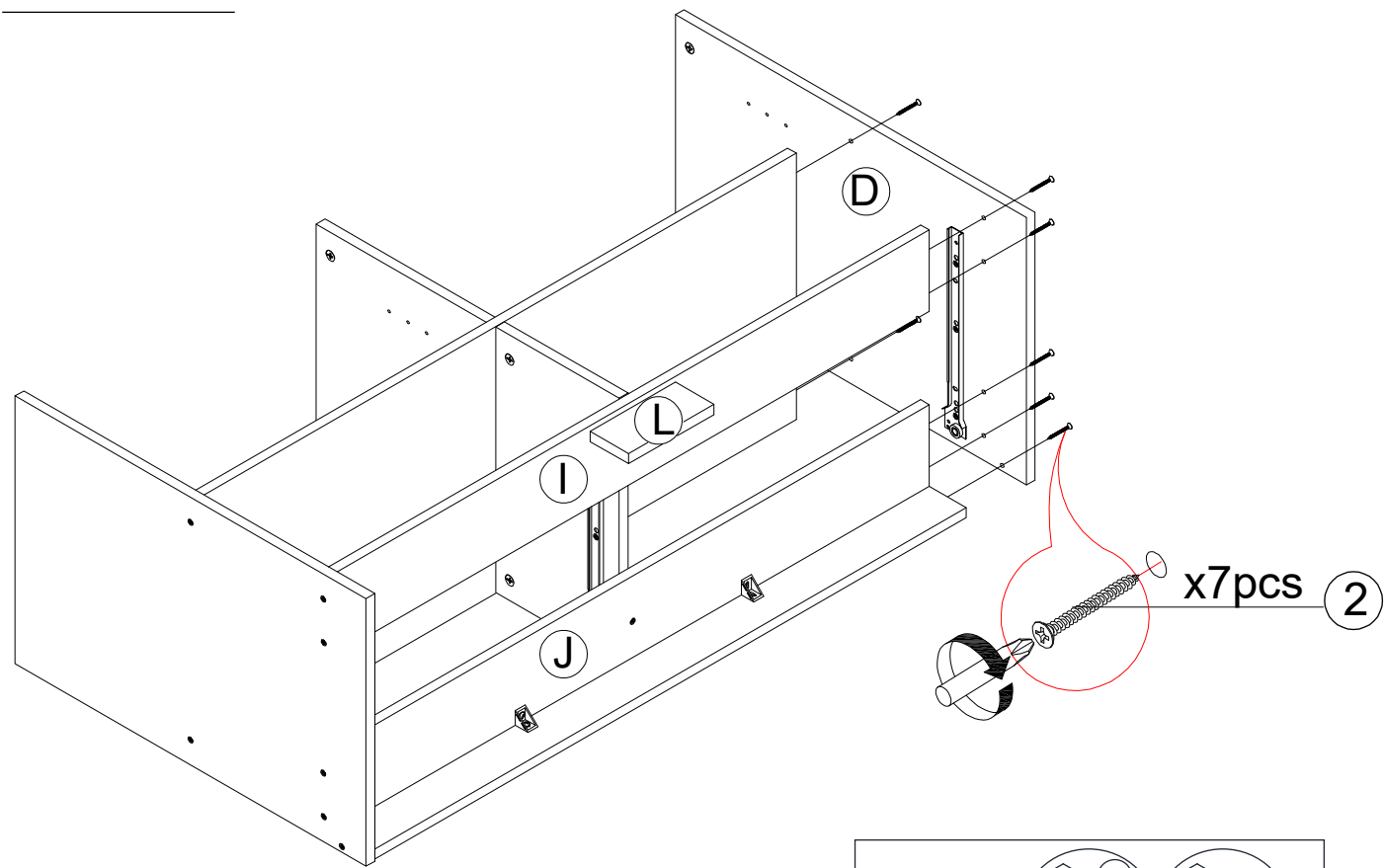

# STEP 10

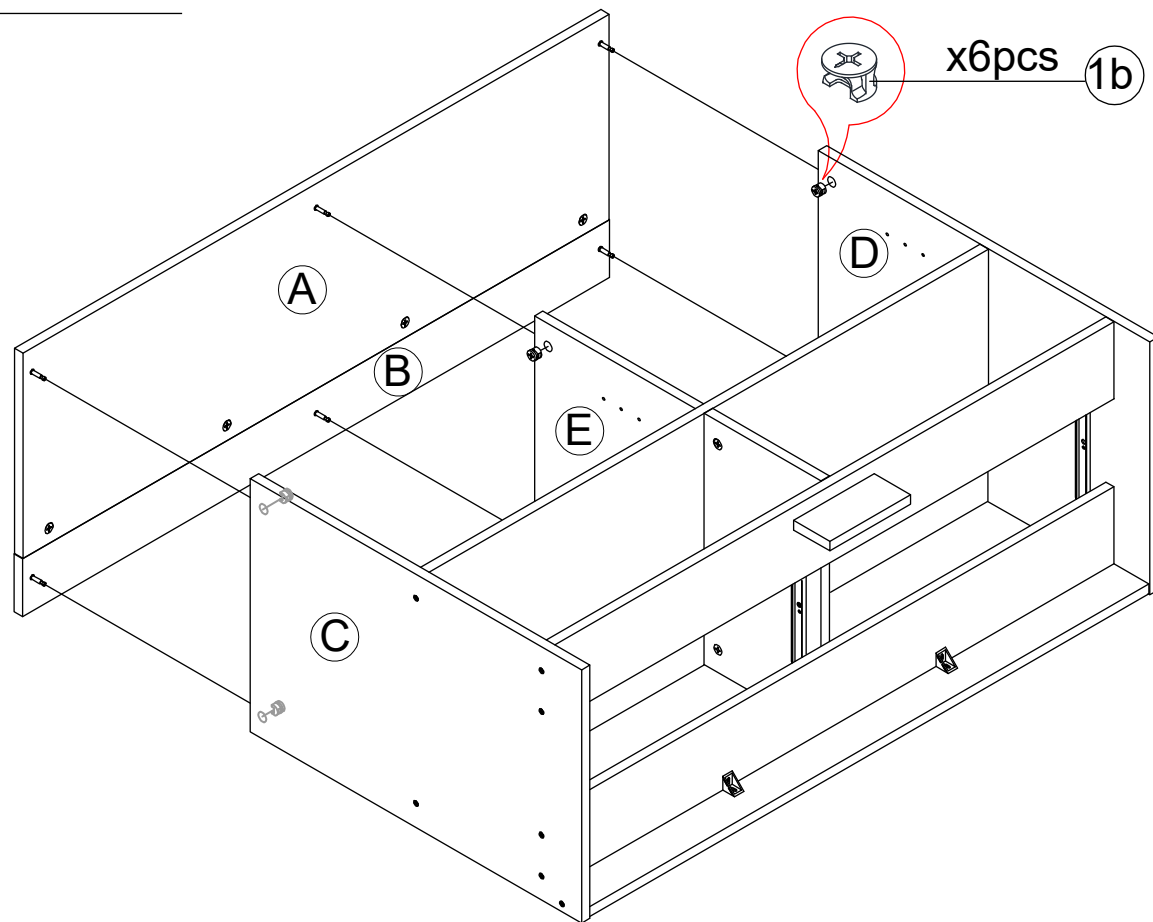

# STEP 3

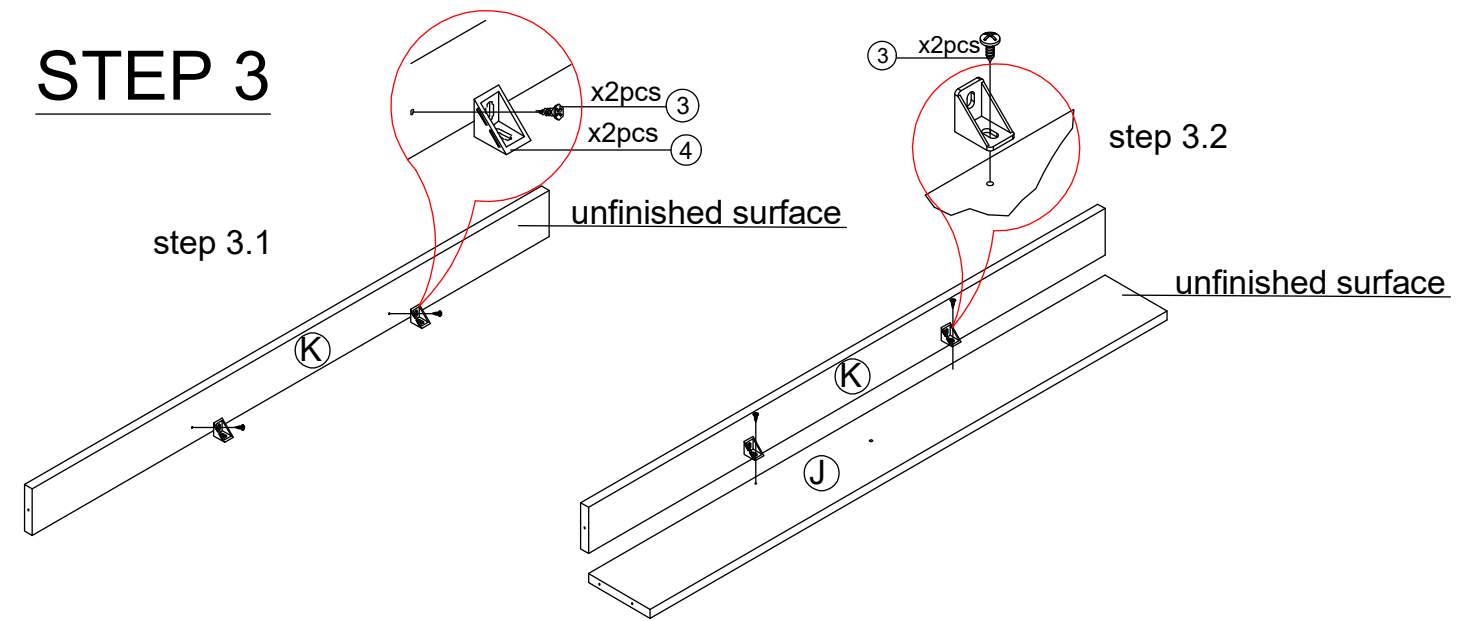

# STEP 4

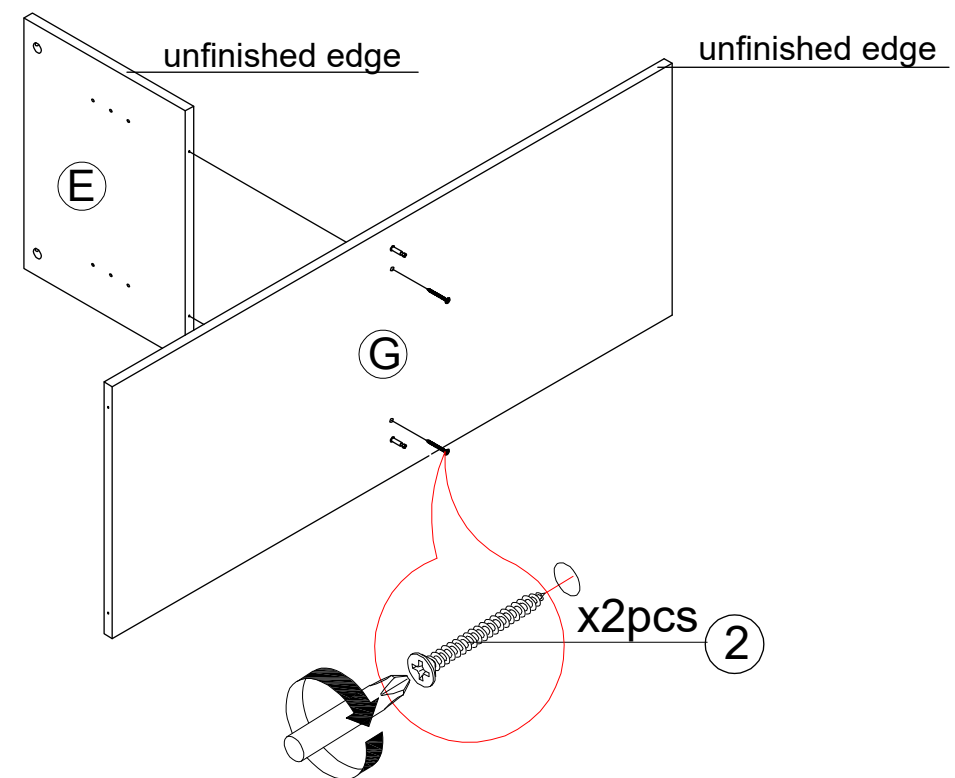

# STEP 5

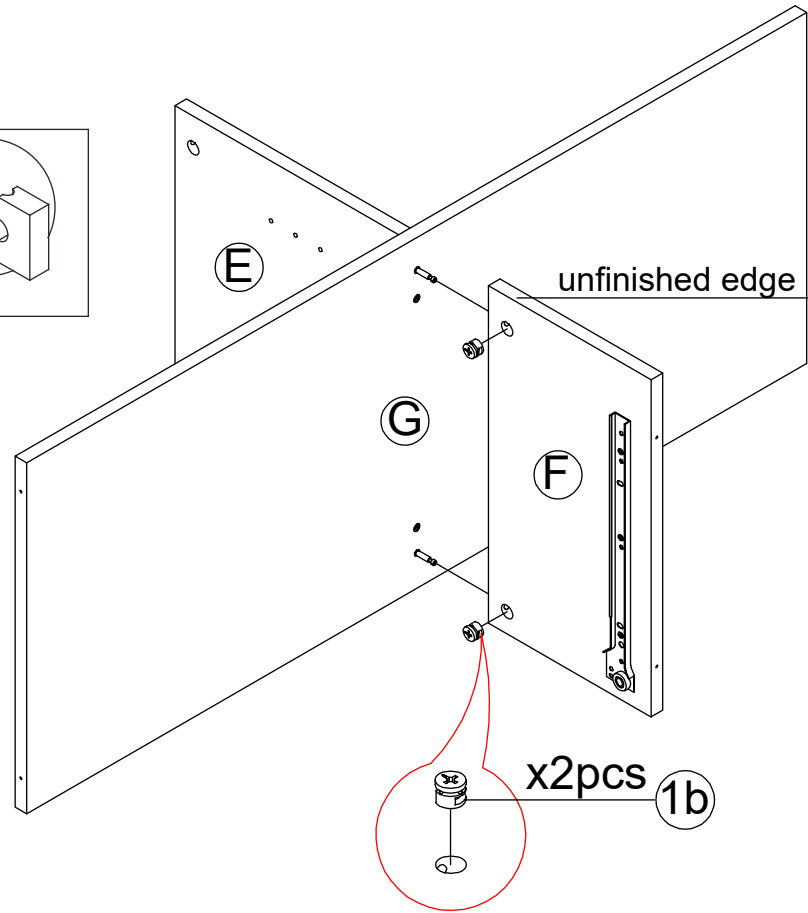
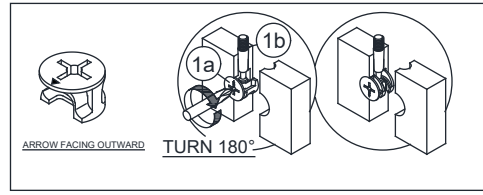

# STEP 6

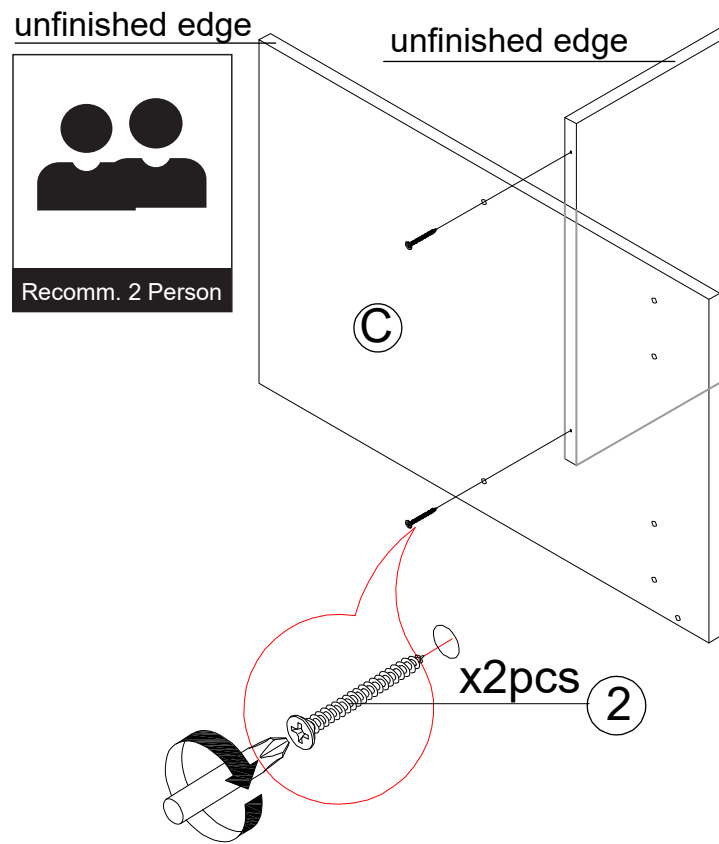

# STEP 7

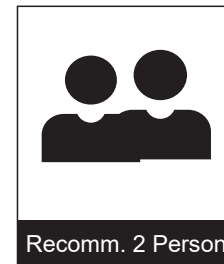
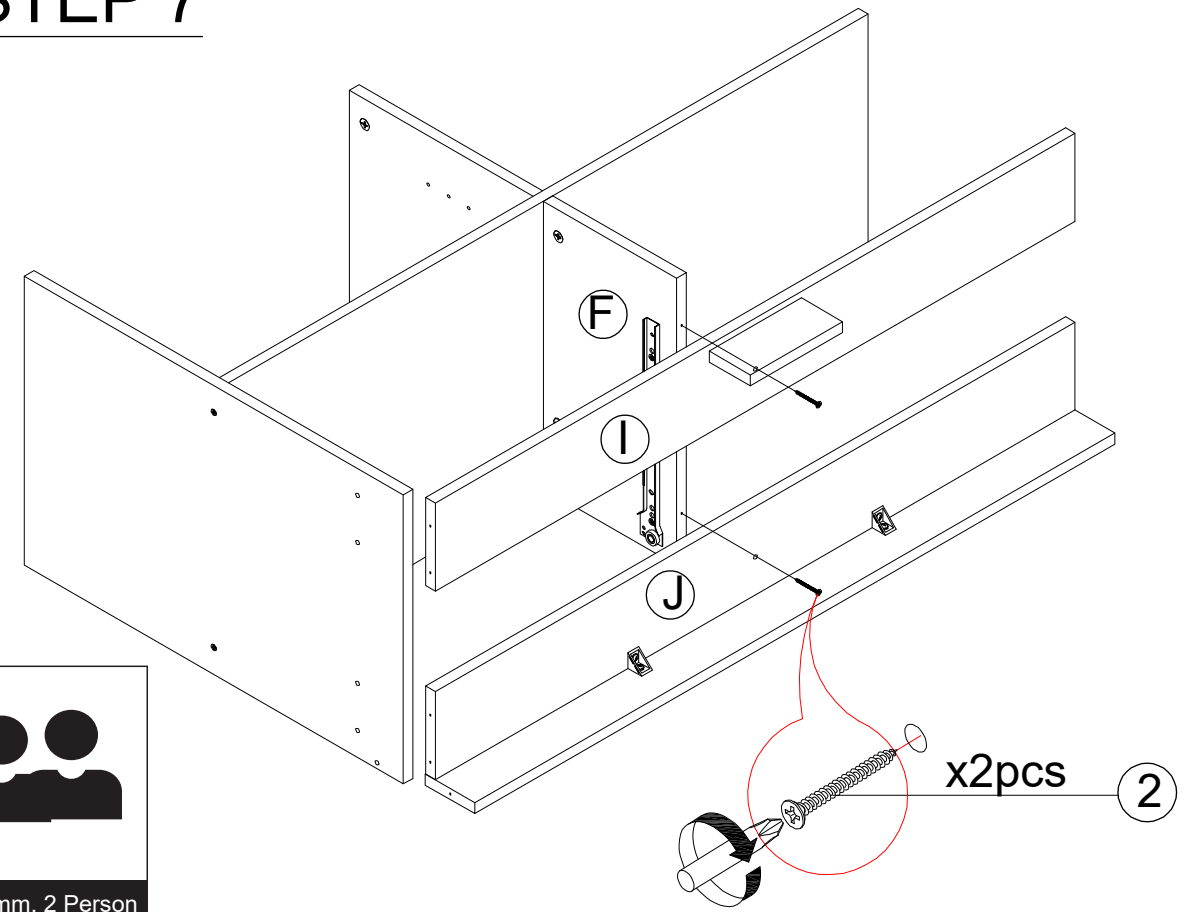

# STEP 8

