

OWNER'S MANUAL

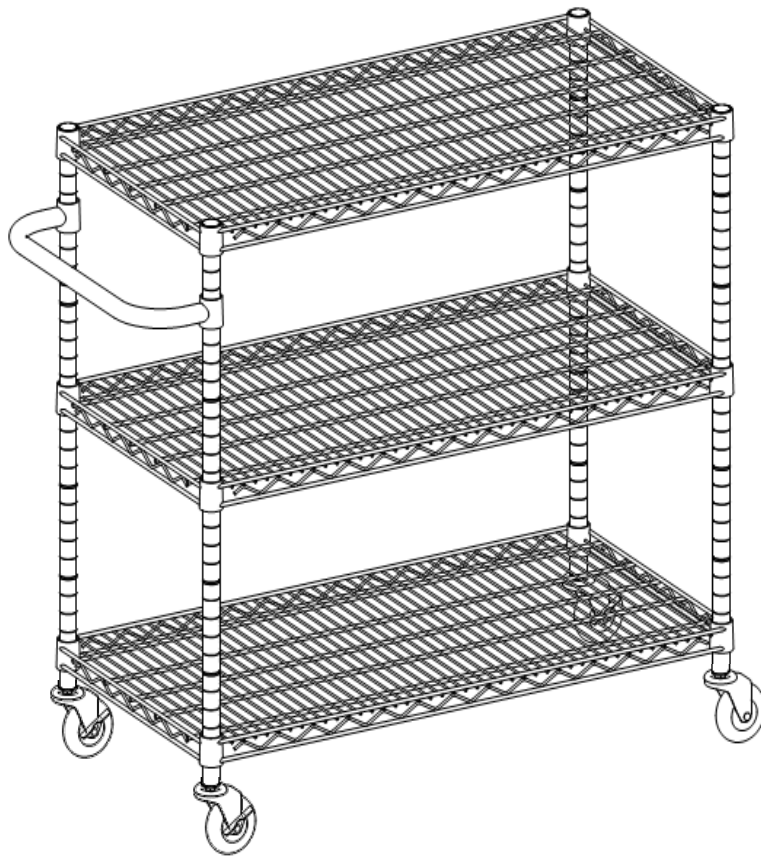

NSF 40.5" x 18" x 36"
3-TIER CART

PARTS LIST

Your 3-Tier Cart should include the following parts. Please inspect box contents to ensure you have received all components.

If you are missing any parts, need assistance with assembly or have questions, please contact our Customer Service.

You will need no additional tools for assembly.

A



POLE (4)
End Cap (4) and
Threaded Insert (4)
are pre-installed

B



SHELF (3)

C

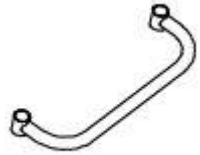

CART HANDLE (1)

D



SLIP SLEEVE
(28) + (4) extra

E

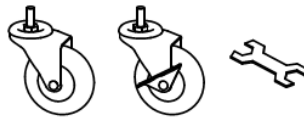

CASTER (w/wrench)
(2 locking, 2 non-locking)

Please inspect box contents to ensure you have received all components.

Note: The black circular plastic tops in between the Shelves are used only for packaging purposes. They are NOT NEEDED. Please discard.

ASSEMBLY INSTRUCTIONS

STEP 1: CASTERS

Screw each CASTER (E) into the bottom of each POLE (A). Turn clockwise to screw in place.

Use the provided caster wrench to tighten completely. Failure to do as instructed could result in the caster stem breaking.

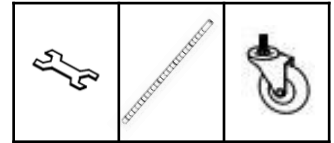

A (4) E (4)

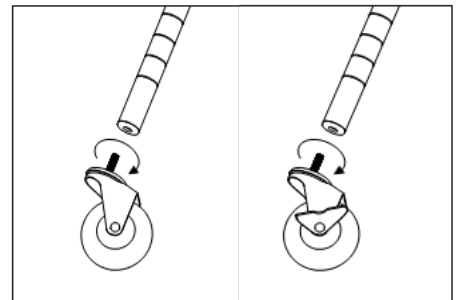

STEP 2: SLIP SLEEVES

Note that each POLE (A) has slight horizontal line indentations at 1" intervals. Each SLIP SLEEVE (D) has raised horizontal lines inside designed to lock them in place on the POLE (A).

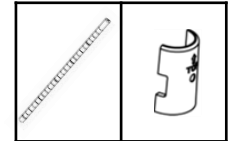

A (4) D (8)

On POLE (A), place 1 pair of SLIP SLEEVES (D) at the desired level. Please make sure the arrow faces up and that the word "TOP" is right side up. Do this for each POLE (A) and make sure that the heights are identical for POLE (A).

Slide the pair of SLIP SLEEVES (D) until you hear a click to confirm the pair is locked onto the POLE (A). DO NOT place more than one pair on each POLE (A) at a time.

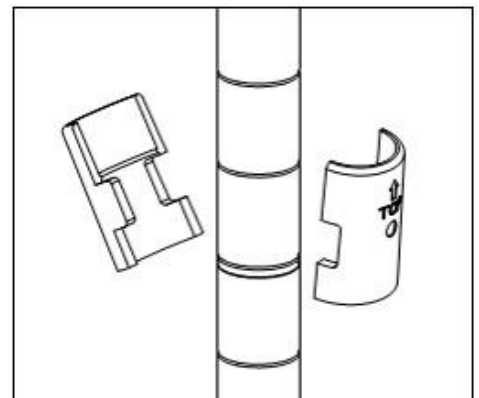

* For safety and stability, the lowest SHELF (B) should be lower than the 3rd notch from the bottom.

** Note: There will be a very small gap in-between the SLIP SLEEVES (D)—this is normal.

ASSEMBLY INSTRUCTIONS

STEP 3: INSTALLING BOTTOM SHELF

Place SHELF (B) on its side and slide the (4) POLES (A) through the holes in the SHELF (B). Make sure that the SHELF (B) corner cylinders are positioned over the SLIP SLEEVES (D).

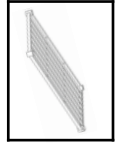

B (1)

Note: Make sure to insert the poles with the Locking Casters on the short side of the Cart.

Stand the unit upright.

**Note: The level side of the SHELF (B) is the TOP side (the logo on the corner cylinders should be right-side up.)*

***Use a rubber mallet, if needed, to secure the SHELVES (B).*

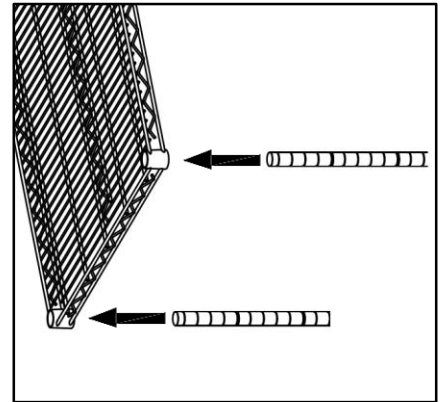

STEP 4: INSTALLING SHELVES

On POLE (A), place 1 pair of SLIP SLEEVES (D) at the desired distance between SHELVES (B). Please make sure the arrow faces up and that the word "TOP" is right side up. Do this for each POLE (A), and make sure that the heights are identical for each POLE (A).

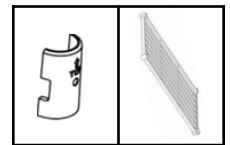

D (8)

B (1)

Lower SHELF (B) over the POLES (A) so that the corner cylinders of the SHELF (B) are positioned over the SLIP SLEEVES (D).

***Use a rubber mallet, if needed, to secure the SHELVES (B).*

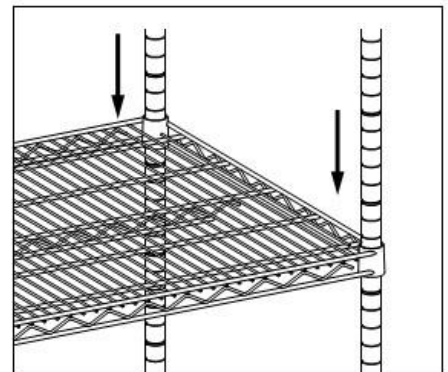

ASSEMBLY INSTRUCTIONS

STEP 5: INSTALLING CART HANDLE

Attach SLIP SLEEVES (D) to the POLES (A) at the desired height for the CART HANDLE (C).

Make sure to put the CART HANDLE (C) in place before attaching the top SHELF (B).

For ease of use, please attach the CART HANDLE (C) to the same side of the Cart as the Locking Casters.

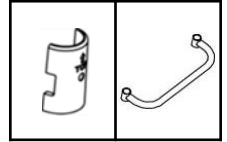

D (4) C (1)

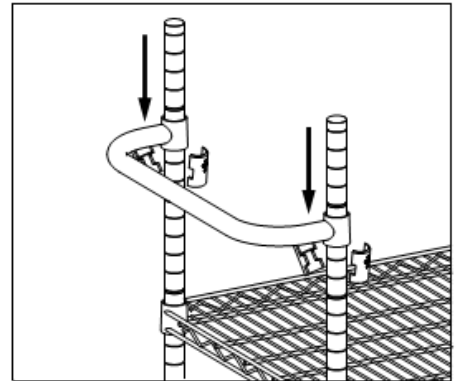

STEP 6: INSTALLING TOP SHELF

Repeat Step 4 to install the last SHELF (B).

****Note:** For safety and stability, the highest SHELF (B) should be higher than the third horizontal indentation from the top.

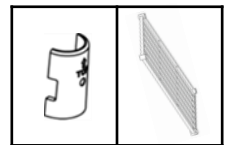

D (8) B (1)

SERVICE PARTS LIST

Customer Service provides the following replacement parts:

Description

- | | |
|-----------------------|-------------------|
| 1) Slip Sleeve | 5) Locking Caster |
| 2) Pole | 6) Cart Handle |
| 3) Non-locking Caster | 7) Endcap |
| 4) Wrench | 8) Shelf |

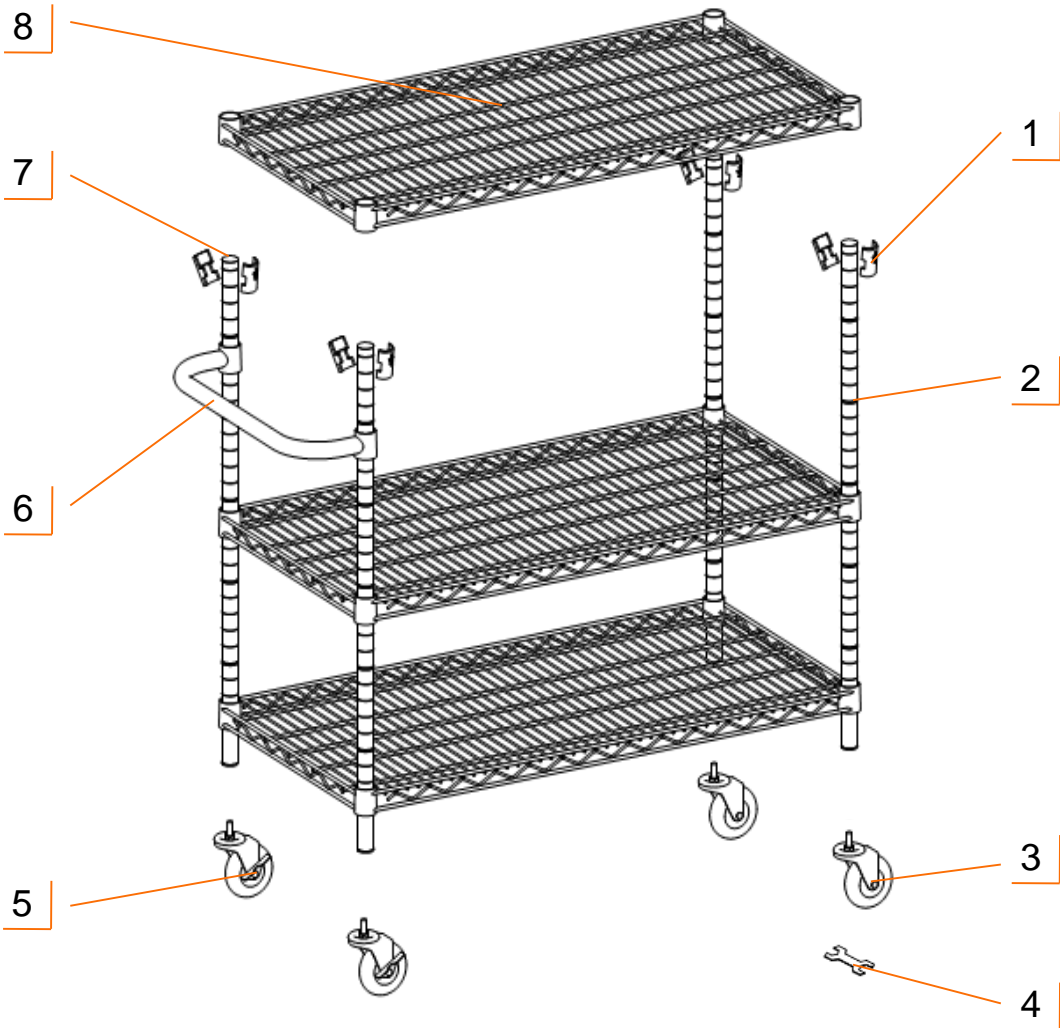

WARNINGS

- 1. Read and understand all instructions.** Failure to follow all instructions may result in injury and/or damage.
- 2. Use the provided caster wrench to tighten casters completely.** Failure to do as instructed could result in the caster stem breaking thereby causing the shelving rack to collapse.
- 3. The warnings, cautions, and instructions discussed in this manual cannot cover all possible conditions or situations that may occur.** The user must always be aware of their environment and ensure that they use the product in a safe and responsible manner.
- 4. Do NOT modify the product in any way.** Unauthorized modification may impair the function and/or safety of the product, and may affect the life of the product.
- 5. Check for damaged parts.** Before using this product, carefully check that all parts are in good condition, and that the product will operate properly and perform its intended function. Check for damaged parts and any other conditions that may affect the operation of this product. Replace damaged or worn parts, and never use this product with a damaged part.
- 6. Do NOT overload the product.**

Weight capacity per Shelf	265 lb (evenly distributed)
Total weight capacity of Cart	800 lb (evenly distributed)

CARE AND MAINTENANCE

- Avoid harsh, abrasive cleaners, and other corrosive chemicals
- This item is not certified for outdoor use

1 YEAR LIMITED WARRANTY

NSF 3-Tier Cart

This warranty excludes normal wear and tear of the Product and its parts or components, and damage arising from any of the following: negligent use or misuse of the Product, use contrary to this User's Manual, or alteration by any one other than this manufacturer. The warranty period of 1 year shall not be extended or renewed by the repair or replacement of, or compensation for, the Product. Any warranty implied by applicable law is limited in duration to one year from the date of purchase and is subject to the same conditions and limitations as is provided for our express warranty.

Except as set forth herein, and to the extent of applicable there are no warranties on this Product either express or implied, and we disclaims all warranties including, but not limited to, any implied warranties of merchantability, infringement or fitness for a particular purpose. No warranty or guarantee given by any person, firm, or corporation with respect to this product shall be binding .

If your Product is defective or otherwise requires service or parts, please call our Customer Service toll-free . Please tell us which model you purchased, the date of the purchase, and the problem with your Product. A copy of your original purchase receipt must accompany your service request.

LIMITATION OF REMEDIES AND LIABILITY

We (and its employees, officers, members, managers, affiliates an assigns) shall not be liable for any incidental, consequential, special, indirect, remote, special or punitive damages for breach of any warranty, express or implied, including, but not limited to, lost profits, lost savings, loss of anticipated benefits and attorneys' fees, which arise out of the purchase, use or inability to use the Product, whether arising out of contract, negligence, strict tort, product liability, or any other legal theory on which a claim is based. As noted above, to the extent damages are allowed by our express warranty or by applicable law, those damages may not exceed the purchase price paid for the Product. Without limiting the foregoing Purchaser assumes all risk and liability for loss, damage or injury to Purchaser and Purchaser's property and to others and their property arising out of the use, misuse, or inability to use this Product. This limited warranty shall not extend to anyone other than the original purchaser of this product, is nontransferable and states your exclusive remedy.

Some states do not allow the exclusion or limitation of incidental, consequential, special, or punitive damages, so the above limitation or exclusion may not apply to you. The above warranty gives you specific legal rights, and you may have other rights which vary from state to state.

CONTACT US

**QUESTIONS? NEED PARTS?
WE ARE HERE TO HELP!**

Please feel free to contact us. There are no questions too small, or any problems too big. We're committed to providing our customers with the highest level of service.