

# **Assembly Instruction**

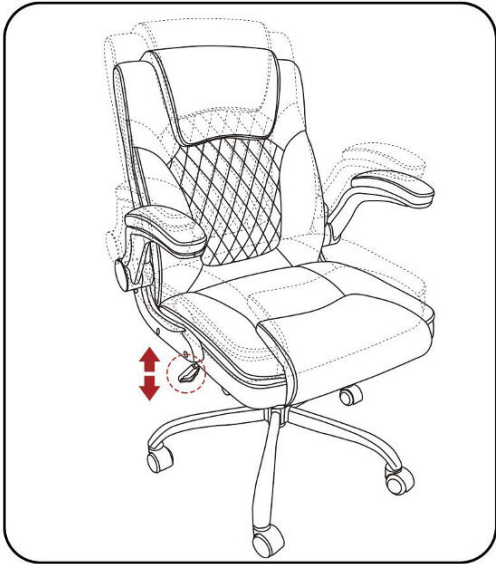

# Instructions for Use



**Up and Down Adjustment**











**Rocking Function**

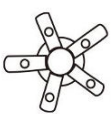
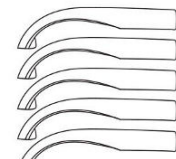

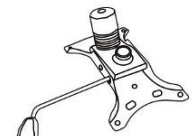
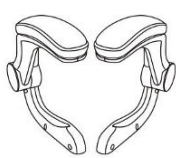
**Flip-Up Armrests**

Thanks for purchasing our products. Please read this manual before assembly. And please assemble in order. After the assembly, keep the instruction properly. Make sure all the parts are included (12 kinds in total)

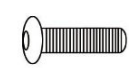
## Accessories List

(A) Central Base Tube 	(B) Foot Stool 	(C) 5 Castors 	(D) Air Rod 	(E) Base Plate 
(F) 2 Armrests 	(G) Backrest 	(H) Seat Cushion 	(I) 9 M6*20mm Screws 	(J) 8 M6*25mm Screws 
(K) 8 Decoration Caps 	(L) Hexagon Wrench 			

## Notice

- Do not stand in this chair or use the chair as a step ladder use it as chair only. This chair is designed for one person to use at a time.
- Do not use this chair unless all bolts, screws and knobs are firmly secured.
- Check all bolts, screws and knobs every 90 days. Tighten them if any are loose.
- Failure to follow these instructions may result in serious injury or death of yourself and people around you.
- Some of the parts are heavy or have sharp edges, please install them carefully to avoid hurting you and people around you.

# Assembly Instruction

Please assemble in a wide and flat place.

## Step 1

Insert 5 Foot Stool (B) into the Central Base Tube (A) as shown. Align with the holes on both sides, tighten 5 M6\*20mm Screws (I) with Hexagon Wrench (L).

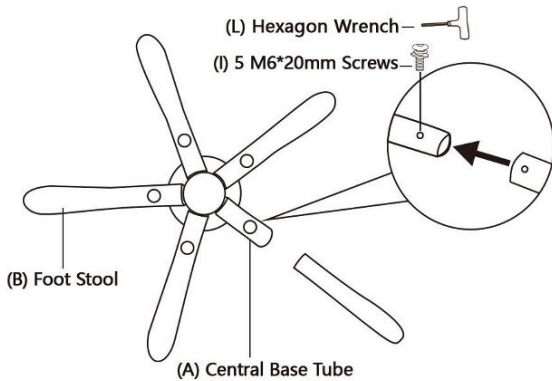

## Step 2

Insert the 5 Castors (C) to the foot stool installed in Step 1 and press them in firmly. Put Air Rod (D) into the hole of central base tube as shown. Then put it aside and we will use it on Step 6.

\* Caution: Confirm Castors (C) must be inserted deeply. Otherwise the Castors could easily fall out and the chair could fall down.

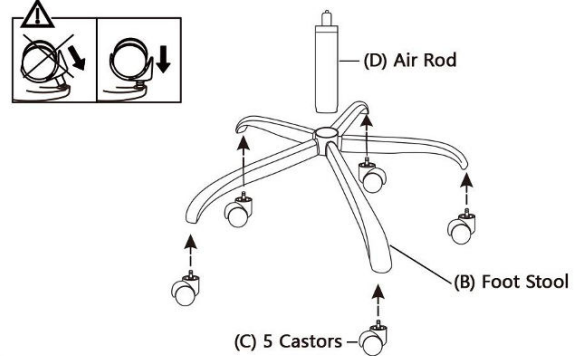

## Step 3

Fix the Base Plate (E) to the bottom of the Seat Cushion (H). Tighten the 4 M6\*20mm Screws (I) with Hexagon Wrench (L) firmly.

\* Caution: Align the direction with the 'FRONT' mark for installation, half-tighten the screws first, and tighten the four screws after aligning the holes to prevent the chassis from shifting and being difficult to tighten.

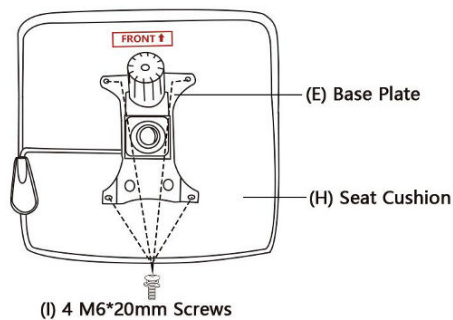

## Step 4

Take out an Armrest (F), tighten the 2 M6\*25mm Screws (J) with Hexagon Wrench (L) and fix the Armrest (F) to one side of the Seat Cushion (H). Place the Backrest (G) on the Seat Cushion (H), align it with the Armrest (F), and secure it with 2 M6\*25mm Screws (J).

\*Caution:Tighten 2 screws to 50% to secure the armrest and seat cushion, then wait until the screws on the back and armrest are aligned and screwed in, and tighten 4 screws to 100%.

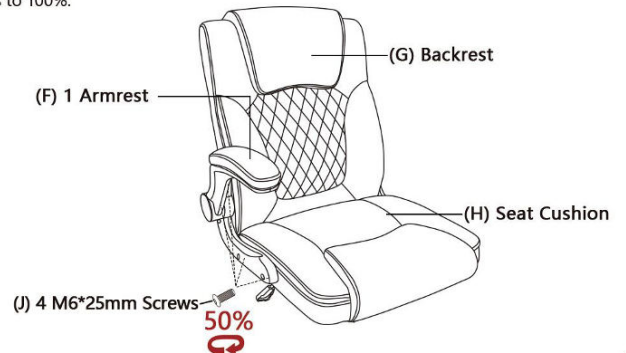

## Step 5

Attach the Armrest (F) to the Cushion (H) and Backrest (G) in the same way as in Step 4. Cover the screw holes on both sides of the Armrest (F) with 8 Decorative Caps (K).

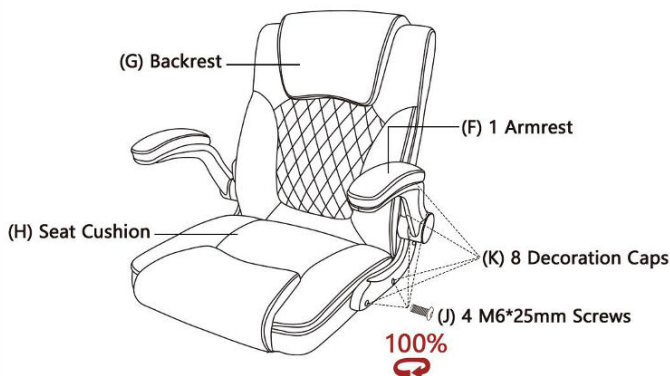

## Step 6

Pick up the Step 2's Air Rod (D) and FootStool (B). Insert the Air Rod (D) into Step 5's Base Plate (E) at the bottom of Seat Cushion (H). There's a hole in the middle of Base Plate (E). Press the Seat Cushion (H) from top to bottom, use your whole body's strength to insert it firmly.

\*Caution:If the Air Rod (D) doesn't insert to Base Plate (E) firmly, it's likely to fall down when the chair raises up.

