

INSTRUCTION MANUAL

Pergola

G30009

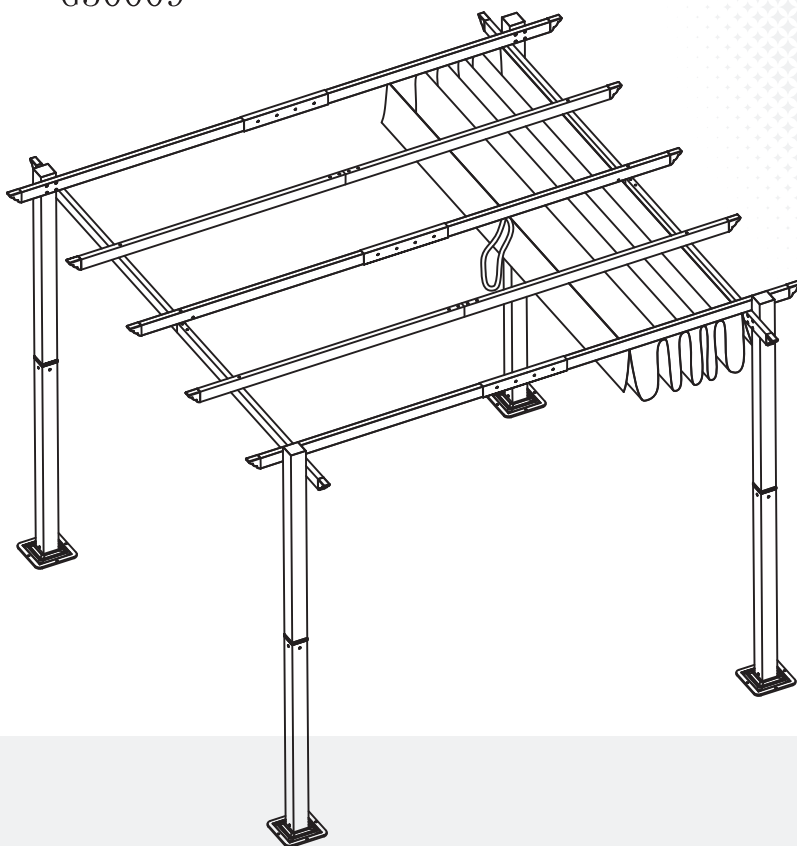

Outdoor Furniture

We are a professional furniture provider with top-notch factories and outstanding designs, Our mission is to provide consumers with new lifestyles. By collecting consumer feedback, we constantly improve our products and create more choices for consumers. If you want to create your space, We are an ideal choice.

Always.



WARNING

Ensure that all parts
and hardware are
available before
beginning assembly

WARNING

- In case of windy weather, please do not stand in the gazebo.
- Please do not stand under the gazebo in case of heavy snowfall.
- For safety, please use expansion screws to reinforce the posts to the ground.
- In windy weather, please tighten the fence and netting to avoid tearing in high winds.
- In extreme weather conditions, you can use a rope to pull the four corners of the gazebo to keep it stable.
- Please clear the snow off the roof in time for the heavy snowfall.
- Make sure all screws are tightened before use.
- Repeat to confirm all screws, buckles and straps every 90 days.
- Please keep all screws loose during the assembly process and tighten them after completing the installation.
- Do not use or store next to a pole with an open flame or flammable chemicals.
- Please note that some parts have sharp edges and should be handled with gloves.
- If any parts are missing, broken, damaged or worn, discontinue use of the product until repairs are made or factory replacement parts are installed.
- Installation of the product in a manner that does not conform to the manufacturer's instructions may result in the loss of the warranty policy for this product.

CALIFORNIA PROPOSITION 65

WARNING: This product can expose you to Carbon monoxide, which is known to the State of California to cause birth defects or other reproductive harm. For more information go to www.P65Warnings.ca.gov

TOOLS REQUIRED



Electric Screwdriver



Manual Screwdriver



Ladder



Gloves



Spanner



2-4 Persons Assembly



Minimum 120 Minutes For Assembly

ATTENTION :

1. Please read this instruction carefully before installation and follow it strictly during installation.
2. Ensure that there are no problems later due to installation errors.
3. We have prepared extra screws for you to use in case of loss or damage.

Installation Notes

Please check the quantity of all parts before installation (Please refer to the Parts Lists) and the appearance of the products. Please make sure the product is correct before installation. If there is any problem, please contact us directly.

Make sure the colored panels are facing outwards and all the holes match. The panels are textured, please install the panels in the order specified in the instructions. All lines and holes must be accurately matched to make the storage shed more stable. Please ensure that all screws are tightened to prevent the product from falling apart.

There is a protective film on the surface to protect the product, please tear it off after installation to get the final presentation. If you do not damage the film during installation, it can also remain on the product to protect the product.

Please place the product on a flat ground to prevent leaning and collapse. If the ground is uneven, the door may can't be closed.



Safety Precautions

We recommend two adults to complete the installation. Two adults installed together will make the installation process easier and safer.

The gloves must be carried to prevent hand cuts during installation.

Take care when using power tools near water the use of a residual current device (RCD) is advised. Please use the electric driver carefully during screwing to prevent the screw from slipping and hurting your hand. (We recommend that beginners use a manual screwdriver for installation.) Be careful not to fall when installing the roof. Please steady the ladder and make sure the product placed on a flat ground.

PLEASE KEEP THIS INSTRUCTION FOR FUTURE REFERENCE.

PARTS

A

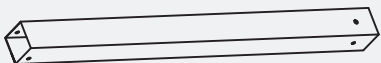

4 PCS

A1

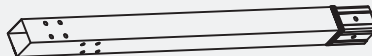

2 PCS

A2



2 PCS

B



2 PCS

B1



2 PCS

C



2 PCS

C1



2 PCS

D



4 PCS

E



2 PCS

F

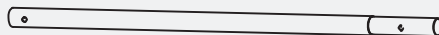

6 PCS

PARTS

F1

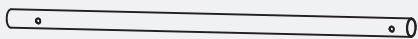

6 PCS

G



3 PCS

H



18 PCS

L

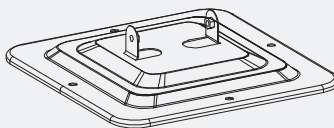

4 PCS

M1



1 PC

M2

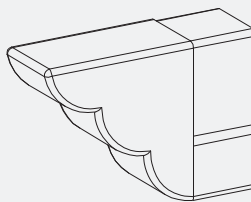

14 PCS

M3

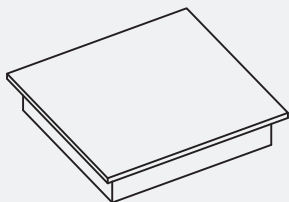

4 PCS

M4

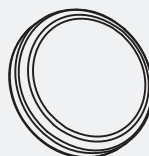

2 PCS

P



4 PCS

Z

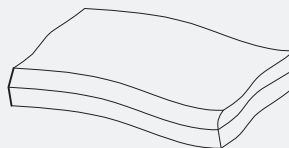

1 PC

HARDWARE

X M 6 x 40mm

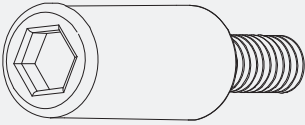

32 PCS

X1 M 6 x 15mm

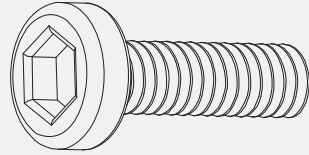

56 PCS

X2 M 6 x 75mm

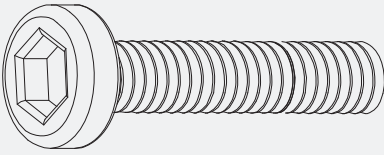

6 PCS

X3 M 6 x 40mm



13 PCS



8 PCS

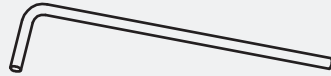

8 PCS

TOOLS

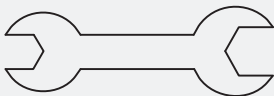

1 PC



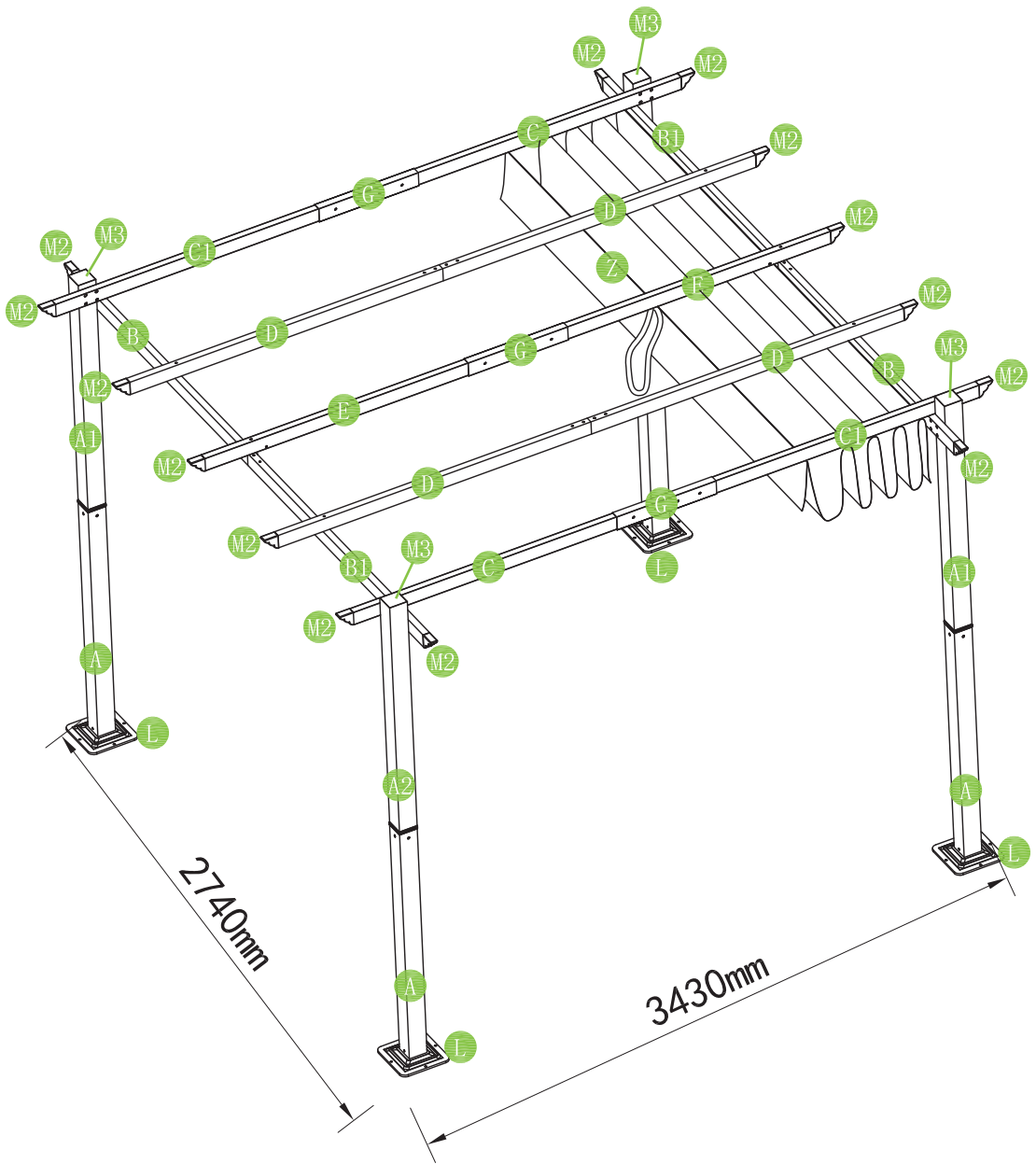

1 PC



PRODUCT ASSEMBLY

1

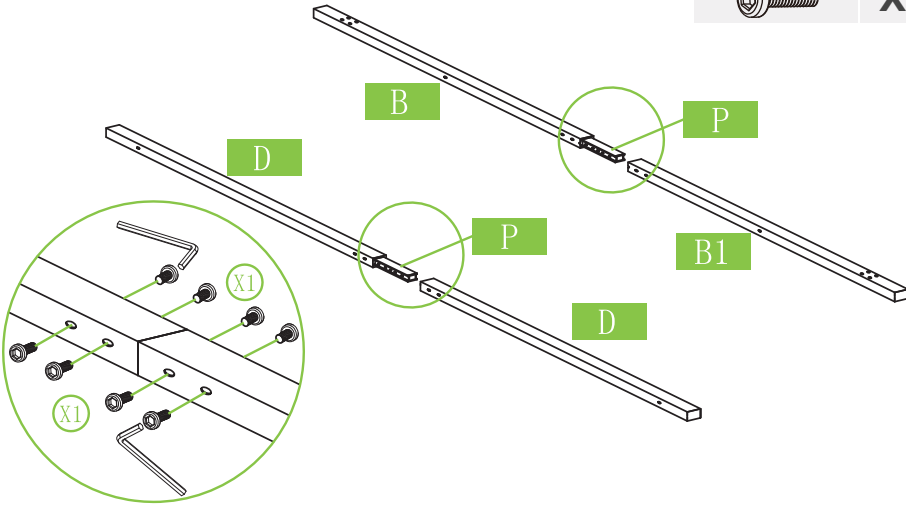

CONNECT (B, B1) (D, D) WITH P, THEN FIXED BY SCREW X1 .

PART	NO.	QTY.
	P	4
	X1	32

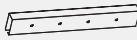

2

CONNECT (C, C1) (E, E) WITH G, THEN FIXED BY SCREW X3

PART	NO.	QTY.
	G	3
	X3	12

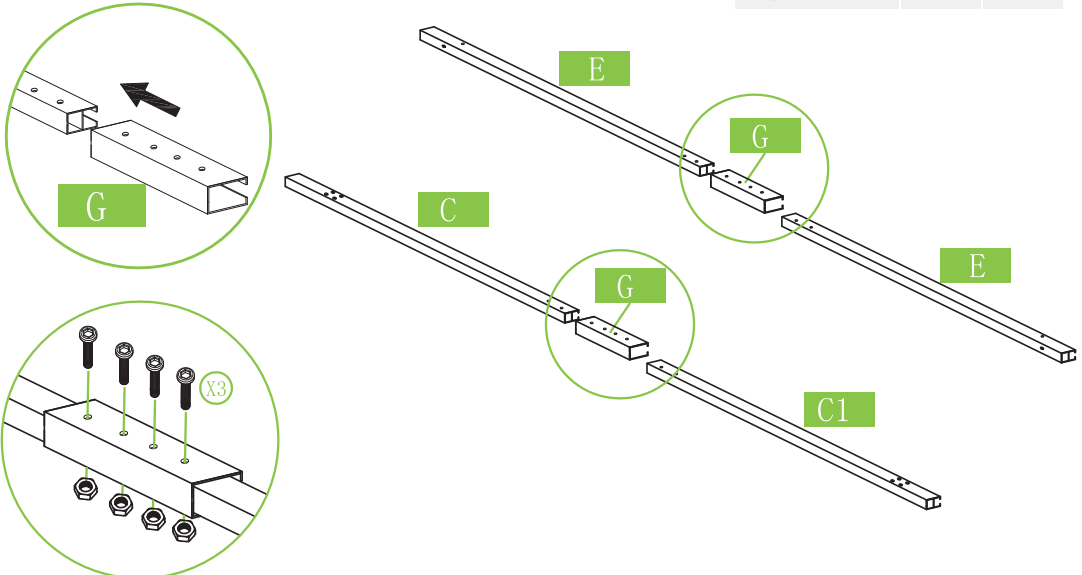

PRODUCT ASSEMBLY

3

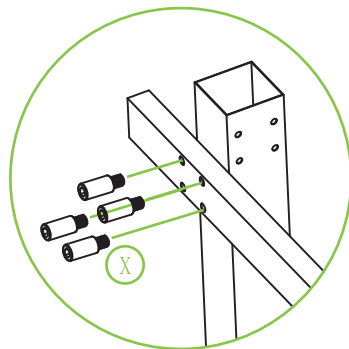
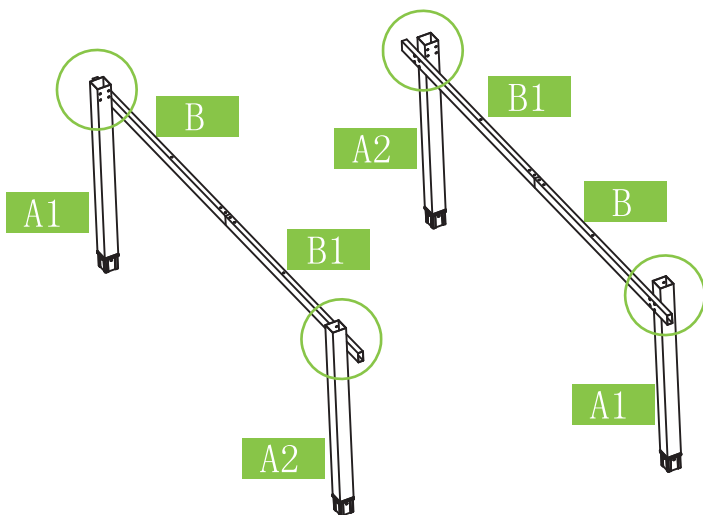

CONNECT (A1, B) (A2, B1) WITH SCREW X.

PART	NO.	QTY.
	X	16



4

PUT PULLEY H INTO CHUTE (C/C1), CONNECT (A1, C1) (A2, C) WITH SCREW X.



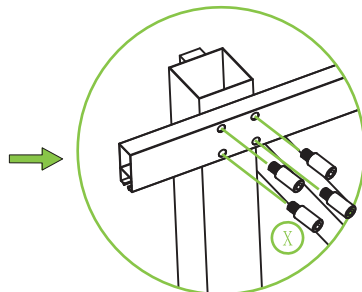
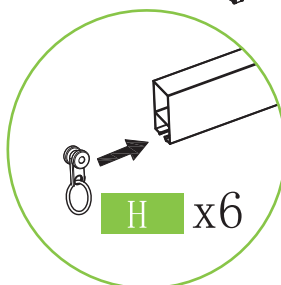
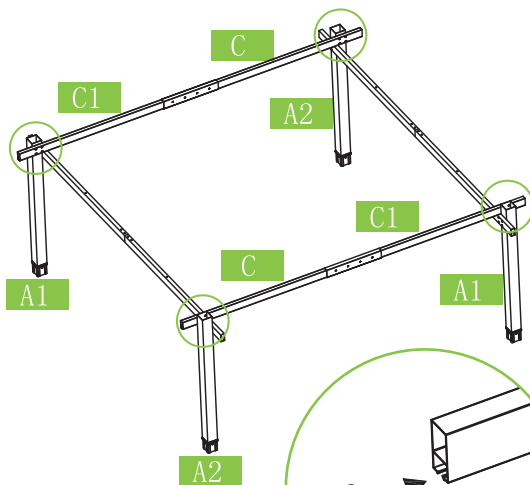

PART	NO.	QTY.
	X	16
	H	12



PRODUCT ASSEMBLY

5

PUT PULLEY H INTO CHUTE E, THEN CONNECT (E, M1) WITH SCREW X2.

PART	NO.	QTY.
	H	6
	M1	1
	M4	2
	X2	6

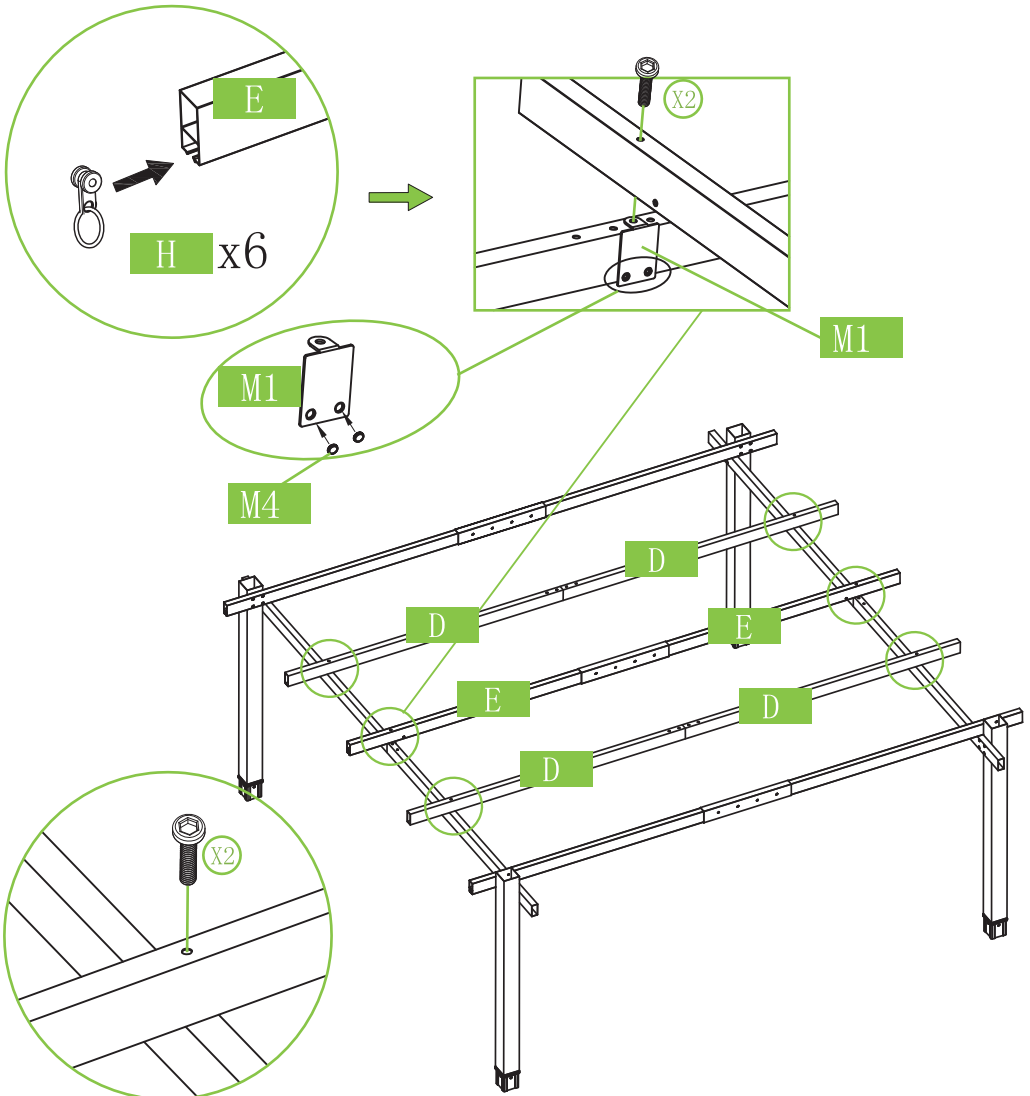

PRODUCT ASSEMBLY

6

CONNECT (F, F1)

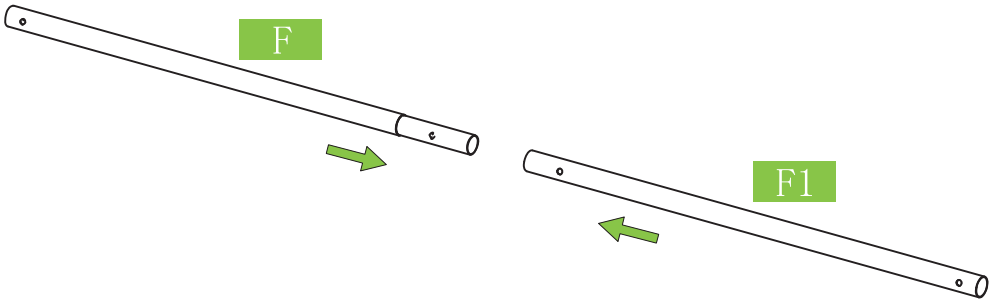

7

(F/F1) CROSS Z.

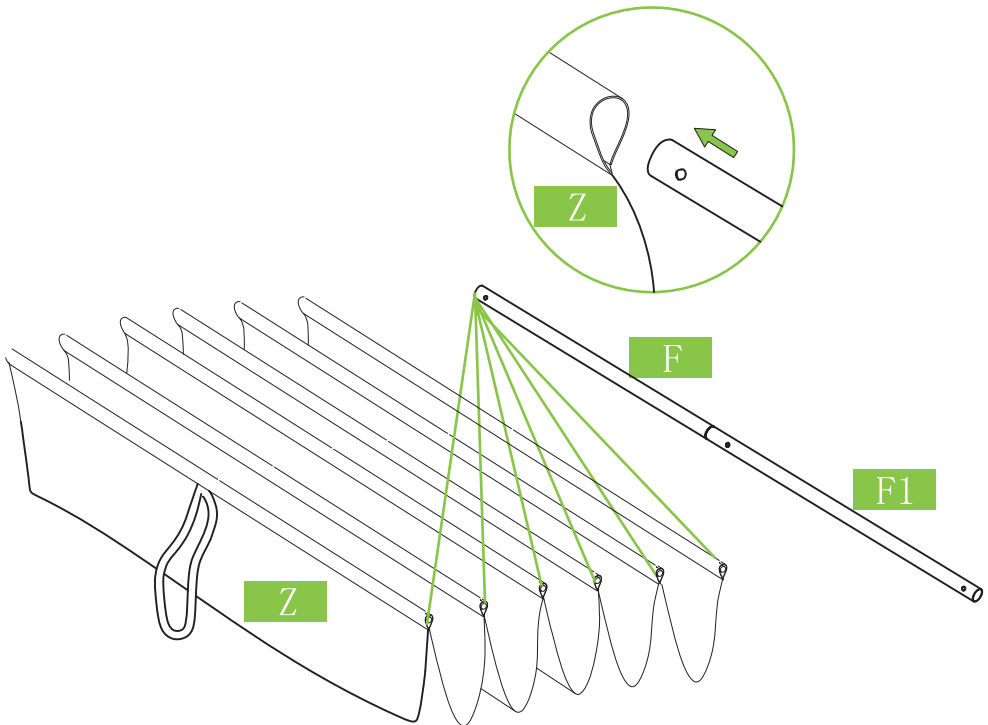

PRODUCT ASSEMBLY

8

INSTALL H ON (F,F1).

PART	NO.	QTY.
	H	18

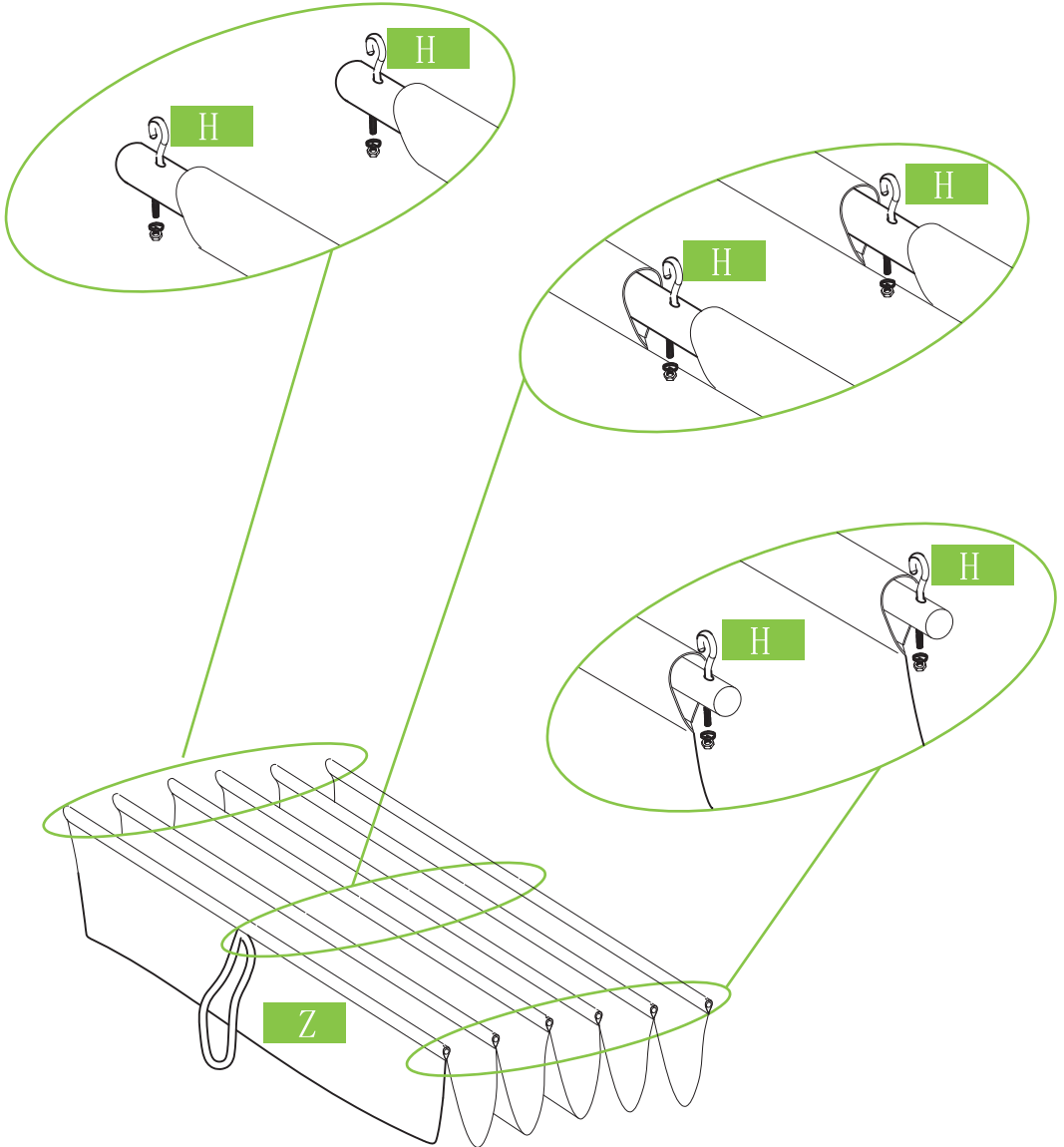

PRODUCT ASSEMBLY

9

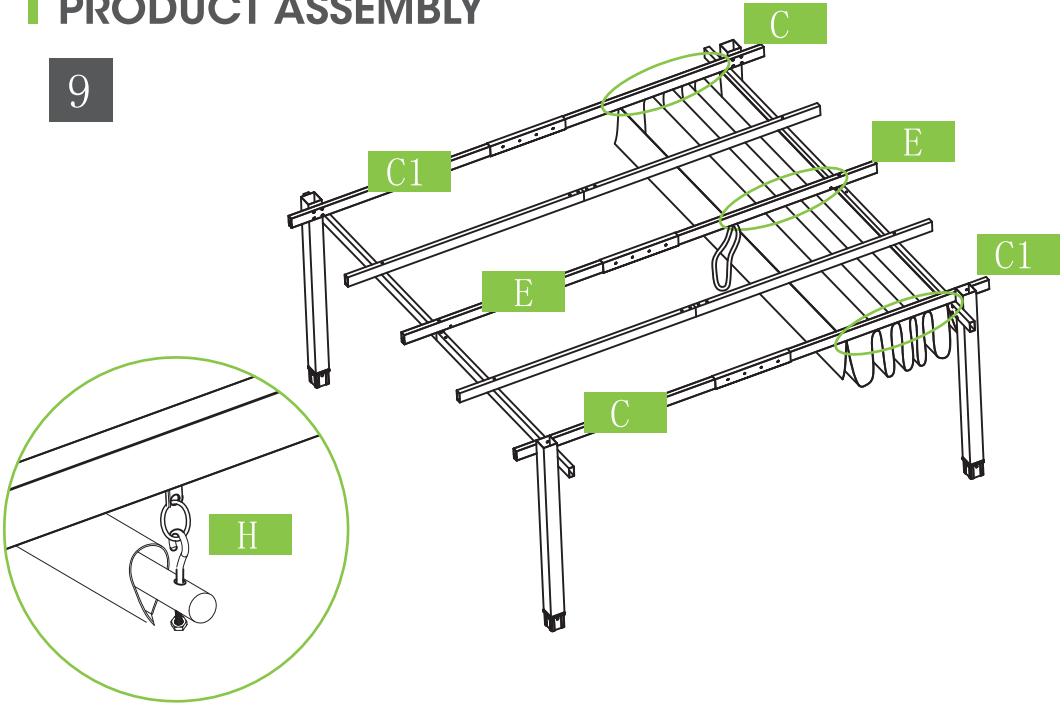

10

USE SCREW X3 TO IMMOBILIZE AN H.

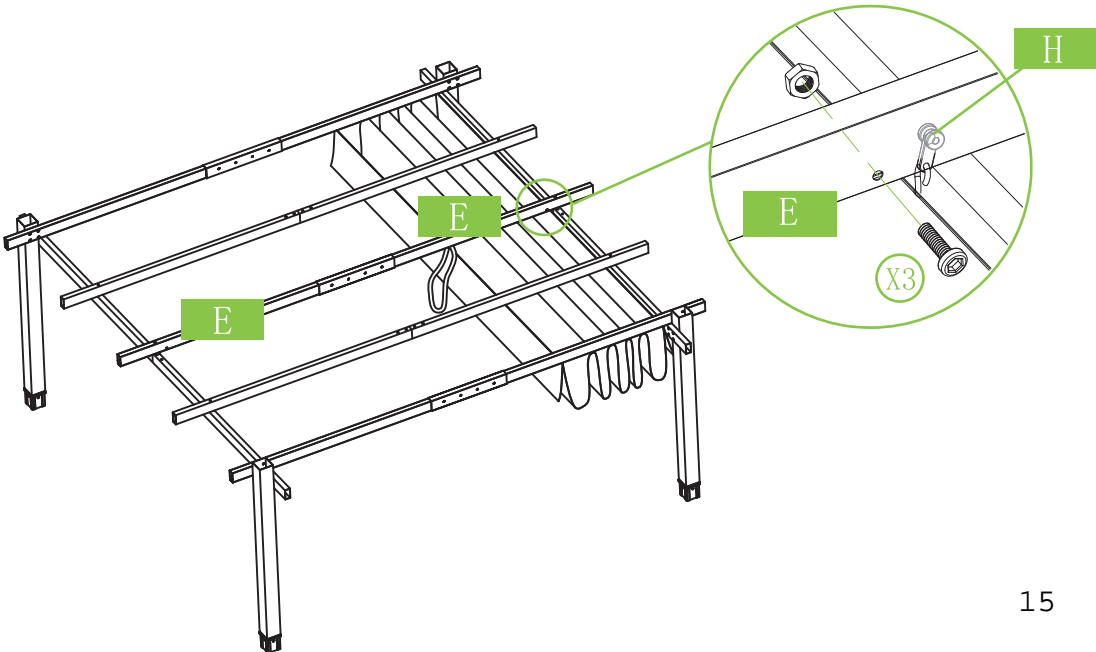

PART	NO.	QTY.
	X3	1



PRODUCT ASSEMBLY

11

INSTALL (M2, M3) SHOWN HERE.

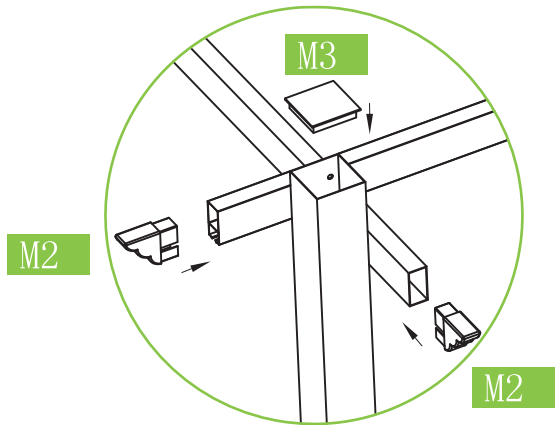
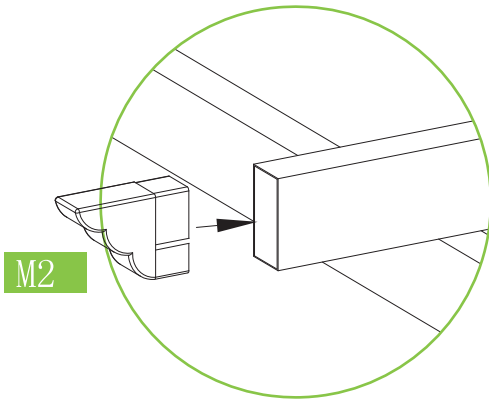
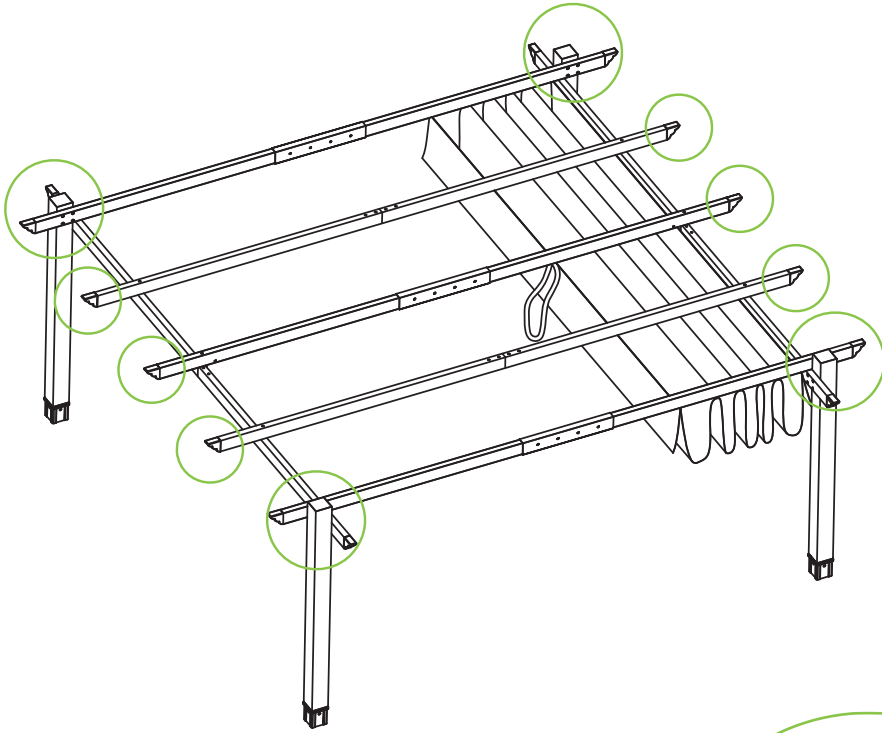

PART	NO.	QTY.
	M2	14
	M3	4



PRODUCT ASSEMBLY

12

CONNECT (A, L) WITH SCREW X1.

PART	NO.	QTY.
	L	4
	X1	8

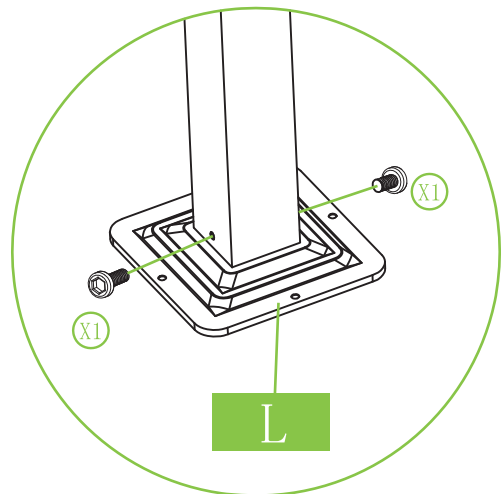
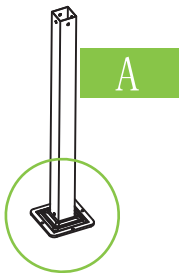
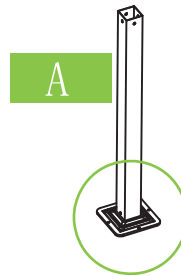
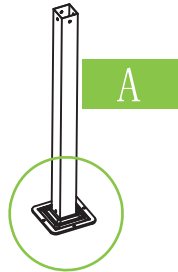
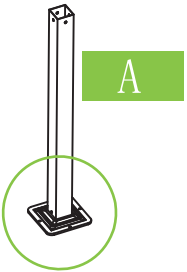

PRODUCT ASSEMBLY

13

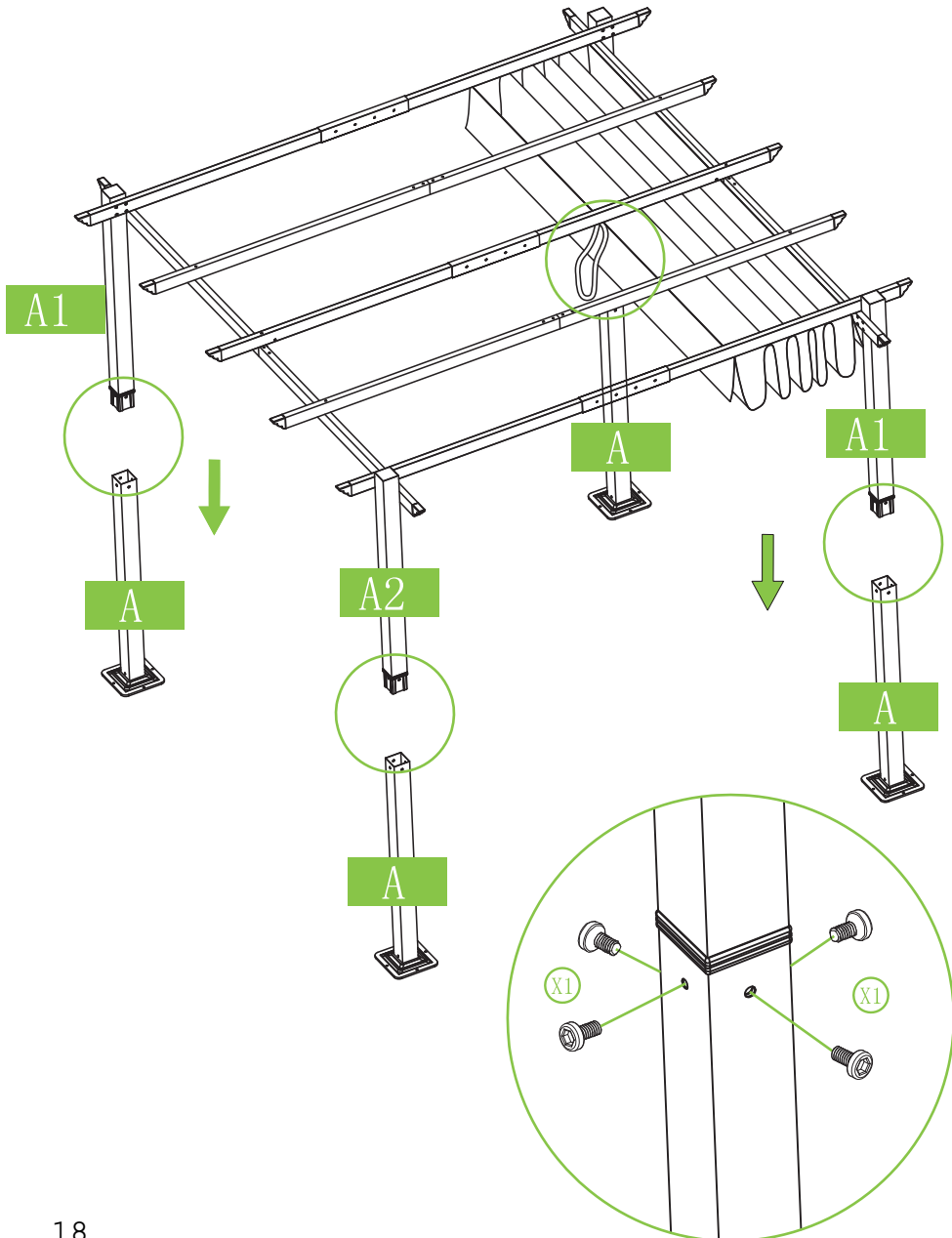

CONNECT (A, A1) (A, A2) WITH SCREW X1.

PART	NO.	QTY.
	X1	16

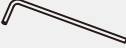

PRODUCT ASSEMBLY

14

PART	NO.	QTY.
		8
		8

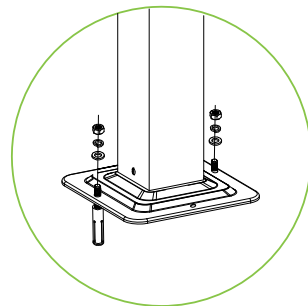
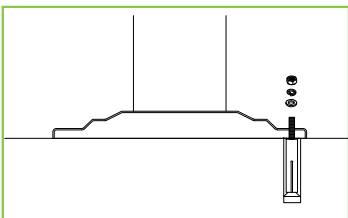
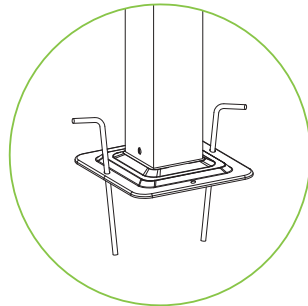
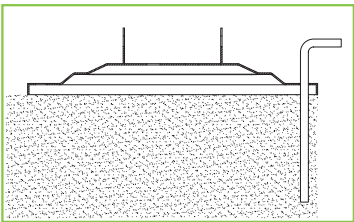
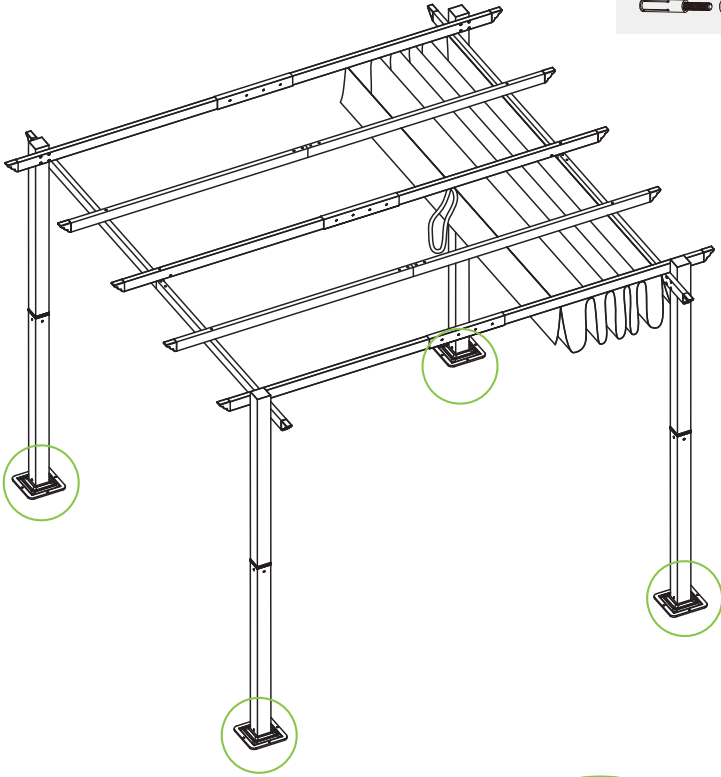

HELP CENTER

Question about your product? We're here to help. Visit us at:



Chat Support



Product Inquiry

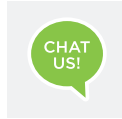

Orders FAQ



Product Assembly



Returns & Refunds

We Stand Behind the Quality of Their Furniture

If you have any issues with your item please let us know! We will always do our best to come up with a solution that you will be happy with. Please get in touch with our customer service team before returning the product.

And pls do not throw the original box(es) if you have not finished assembling or confirmed no quality issues.

Length of return period:

Items can be returned within 30 days of purchase. In the meanwhile, everything you purchased from us comes with a one-year warranty.

Who is responsible for the return shipping fee:

We will cover the return shipping fees if:

1. Your item has a manufacturing defect in its materials or workmanship. For example, torn wicker or misaligned screw holes. We will send you a prepaid shipping label after photos are sent.
2. Your item has been damaged in transit. For example, glass is broken or wicker is damaged. We will send you a prepaid shipping label after photos are sent.
3. You receive the wrong box(es) due to a warehouse error. We will send you a prepaid shipping label after photos are sent of the wrong SKU numbers on the outer box(es).
4. One or more boxes are lost in transit. We will send you a prepaid shipping label if you no longer want the item.

Return Request

In order to get a full refund as described in this return policy, all items must be:

- (1) In a brand new/unused condition, please provide photos before and after packaging.
- (2) When returning, all accessories and parts are firmly packed in all original packaging.

If your return does not meet the requirements, you may not get a full refund.

When will I be refunded? The refund is released once the goods have been returned to our warehouse. What if the product is damaged/defective outside of the valid return period? We want you to be a happy customer.

Please reach out to us by email and we will come up with a solution to make sure you are satisfied.