

Warnung

Das Aufbauen des Artikels muss von Erwachsenen erledigen.

1. Bitte entfernen Sie alle Montageteile bevor Sie den Artikel Ihrem Kind abgeben. abgeben. Nach dem kompletten aufbauen können Sie dem Kind erst den Artikel geben.
2. Bitte entfernen Sie alle Montageteile und Verpackungsmaterialien aus der aus der
3. Spitze Stelle an den Montageteilen kann es zu einer potentiellen Verletzungsgefahr für das Kleinkind kommen.
4. Der Artikel soll das Kind auf glattem Boden spielen. Und beim Verwenden vermeiden Sie bitte diese Stellen, Swimmingpool, Treppen, Fahrweg, Abhang und Straßen. Von Feuer fernhalten.
5. Überprüfen Sie bitte regelmäßig es, ob jede Montageteile noch zueinander dicht stehen. Und pflegen Sie bitte die Hauptteile des Artikels.
6. Entfernen Sie den Artikel sofort aus der Reichweite des Kindes sofern Bruchstellen oder andere Materialermüdungen sichtbar werden.
7. Bewahren Sie bitte die Anweisung für zukünftige Verwendung.
8. Achtung. Nicht für Kinder unter 36 Monaten geeignet!

Dieses Produkt entspricht den europäischen Normen EN71 Sicherheitsnorm für Spielzeug und ASTM F963 für USA. SOR2011-17 für Canada.

Um potentielle Holzsplitterung zu vermeiden, bitte wenden Sie beim Einschrauben der Schrauben nicht zu viel Kraft auf.



Made in China



WARNINGS

36M+

**THE SAFETY OF YOUR CHILD IS YOUR RESPONSIBILITY.
NEVER LEAVE YOUR CHILD UNATTENDED.**

1. Adult assembly required. Remove all packaging and complete assembly before giving this toy to your child.
2. Due to functional sharp point at screws, potentially hazardous may be formed. Keep all assembly parts and packaging materials out of reach of children.
3. Only use on flat, horizontal ground. This toy is not intended to be used close to or in stairs, steps, inclines, swimming pools, or roads. Keep away from fire.
4. To be used under direct supervision of an adult at all times.
5. Carry out regular checks to ensure fitting and fastening are secure.
6. Discontinue use at the first signs of damage or weakness.
7. Retain packaging information for future reference.
8. Not suitable for children under 36 months!

This product conforms to European standards EN71 safety standard for toys and ASTM F963 for USA, SOR2011-17 for Canada.

Clean with a damp sponge.



Made in China



Assemblage adulte requis.

En raison de la pointe acérée fonctionnelle des vis, un danger potentiel peut être formé. Veuillez garder toutes les pièces d'assemblage et les matériaux d'emballage hors de portée des enfants.

Ce jouet n'est pas destiné à être utilisé à proximité de la baignade piscines, escaliers, routes, rues de collines ou pentes. Tenir éloigné du feu.

Les enfants de moins de 36 mois doivent être utilisés sous la surveillance directe de un adulte. Existe le risque de chute.

Compétence requise. Pour éviter d'éventuelles blessures par eux-mêmes ou par d'autres, les enfants devrait être rappelé d'utiliser les jouets avec précaution pour éviter les chutes ou les collisions.

A n'utiliser que par un seul enfant.

Pour éviter d'éventuelles blessures, veuillez mettre des chaussures dans le cours, recommander aux enfants de porter des équipements de protection tels que : casques, gants, genouillères, coudières.

S'il vous plait donner un entretien régulier et vérifier l'étanchéité et le principal

pièces (telles que le système de freinage).

Veuillez conserver cet emballage pour référence future.

Ce produit est conforme aux normes européennes EN71 norme de sécurité pour jouets et ASTM F963 pour les Etats-Unis ,SOR2011-17.



WARNING:
CHOKING HAZARD – Small parts.
Not for children under 3 yrs.



El montaje del artículo debe ser realizado por un adulto.

1. Requiere montaje por parte de un adulto. Retire todo el embalaje y complete el montaje antes de dar este juguete a su hijo.
2. Debido a la funciónl punta afilada en los tornillos,potencialmente peligrosos pueden formarse.Mantenga todas las piezas de montaje y materiales de embalaje fuera del alcance de los niños.
3. Este juguete no está diseñado para ser utilizado cerca o en escaleras, escalones, pendientes, piscinas o carreteras. Manténgalo alejado del fuego.
4. Utilizar siempre bajo la supervisión directa de un adulto.
5. Realice comprobaciones periódicas para asegurarse de que el montaje y la fijación son seguros.
6. Interrumpir el uso a los primeros signos de daño o debilidad.
7. Conserve la información del embalaje para futuras consultas.
8. No apto para niños menores de 36 meses.

Este producto cumple las normas europeas EN71 de seguridad para juguetes y ASTM F963 para EE.UU.,SOR2011-17 para Canadá. No aplique una fuerza excesiva al apretar los tornillos para evitar astillar la madera.



Made in China



Il montaggio dell'articolo deve essere effettuato da adulti.

1. Rimuovere tutte le parti di montaggio prima di consegnare l'articolo al bambino.consegnare l'articolo. È possibile consegnare l'articolo al bambino solo dopo che è stato completamente assemblato.
2. Rimuovere tutte le parti di montaggio e i materiali di imballaggio dall'articolo.
3. le parti di montaggio possono rappresentare un potenziale rischio di lesioni per il bambino.
4. L'articolo è destinato a far giocare il bambino su un pavimento liscio. Durante l'utilizzo, evitare i seguenti luoghi: piscina, scale, vialetti, pendii e strade. Tenere lontano dal fuoco.
5. Controllare regolarmente se le parti di montaggio sono ancora ben salde tra loro. Inoltre, si prega di mantenere le parti principali dell'articolo.
6. togliere immediatamente l'articolo dalla portata del bambino in caso di rottura o di affaticamento del materiale.
7. conservare le istruzioni per un uso futuro.
8. attenzione. Non adatto a bambini di età inferiore a 36 mesi!

Questo prodotto è conforme alle norme europee EN71 standard di sicurezza per i giocattoli e ASTM F963 per gli USA. SOR2011-17 per il Canada.

Per evitare potenziali schegge di legno, non usare troppa forza. non usare troppa forza quando si avvitano le viti.



Dit artikel moet door een volwassene in elkaar worden gezet.

1. Montage door volwassene vereist. Verwijder alle verpakking en voltooi de montage voordat u dit speelgoed aan uw kind geeft.
2. Er kunnen potentieel gevaarlijke schroeven ontstaan door de scherpe hoekige kenmerken op de schroeven. Houd alle geassembleerde onderdelen en verpakkingsmaterialen buiten het bereik van kinderen.
3. Dit speelgoed is niet bedoeld voor gebruik in de buurt van trappen, treden, hellingen, zwembaden of wegen. Houd het uit de buurt van ontstekingsbronnen.
4. Gebruik het speelgoed altijd onder direct toezicht van een volwassene.
5. Controleer regelmatig of de montage en aansluitingen goed vastzitten.
6. Stop het gebruik bij de eerste tekenen van schade of onveiligheid.
7. Bewaar de informatie op de verpakking voor toekomstig gebruik.
8. Niet geschikt voor kinderen jonger dan 36 maanden.

Dit product voldoet aan de Europese EN71 veiligheidsnorm voor speelgoed en de Amerikaanse ASTM F963, Canadese SOR2011-17. Gebruik niet te veel kracht bij het aandraaien van de schroeven om splinters in het hout te voorkomen.



Made in China



Föremålet måste monteras av en vuxen person.

1. Den måste monteras av en vuxen. Ta bort all förpackning och slutför monteringen innan du lämnar leksaken till ett barn.
2. Potentiellt farliga skruvar kan bildas på grund av skruvarnas skarpa vinklar. Förvara alla monterade delar och förpackningsmaterial utom räckhåll för barn.
3. Denna leksak är inte avsedd att användas i närheten av trappor, trappsteg, ramper, simbassänger eller vägar. Förvaras åtskilt från antändningskällor.
4. Använd alltid under direkt uppsikt av en vuxen.
5. Kontrollera regelbundet att monteringen och anslutningarna är säkra.
6. Sluta använda produkten vid första tecken på skada eller osäkerhet.
7. Spara informationen på förpackningen för framtida bruk.
8. Ej lämplig för barn under 36 månaders ålder.

Denna produkt uppfyller den europeiska standarden EN71 för leksakssäkerhet, den amerikanska standarden ASTM F963 och den kanadensiska standarden SOR2011-17. Använd inte för mycket kraft för att undvika stänk av träflis. Använd inte överdriven kraft vid åtdragning av skruvar.



Ten produkt musi być montowany przez osobę dorosłą.

1. Wymagany jest montaż przez osobę dorosłą. Przed przekazaniem zabawki dziecku należy usunąć całe opakowanie i dokonać montażu.
2. Potencjalnie niebezpieczne ze względu na ostre elementy śrub. Wszystkie zmontowane części i materiały opakowaniowe należy przechowywać w miejscu niedostępnym dla dzieci.
3. Zabawka nie jest przeznaczona do użytku w pobliżu schodów, stopni, ramp, basenów lub dróg. Przechowywać z dala od źródeł zapłonu.
4. Zawsze używaj tej zabawki pod bezpośrednim nadzorem osoby dorosłej.
5. Regularnie sprawdzać montaż i połączenia pod kątem szczelności.
6. zaprzestać używania zabawki, gdy tylko zauważy się uszkodzenia lub oznaki braku bezpieczeństwa.
7. zachować informacje na opakowaniu do wykorzystania w przyszłości.
8. Nieodpowiednie dla dzieci w wieku poniżej 36 miesięcy.

Ten produkt jest zgodny z europejską normą EN71 dotyczącą bezpieczeństwa zabawek, amerykańską normą ASTM F963 i kanadyjską normą SOR2011-17.

Aby uniknąć odprysków drewna, nie należy używać nadmiernej siły. Nie używaj nadmiernej siły podczas dokręcania śrub.



Made in China



INSTRUCTIONS

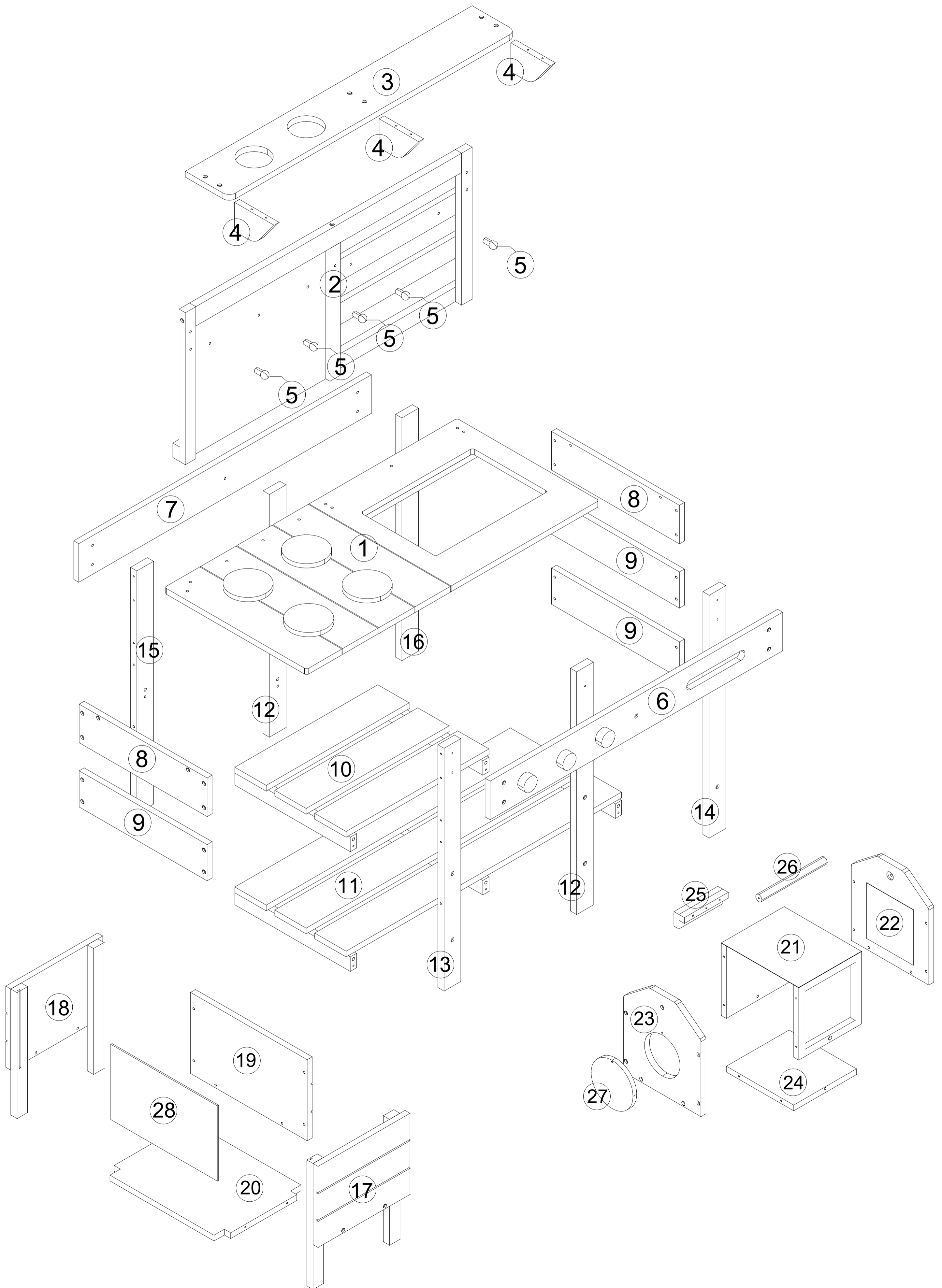

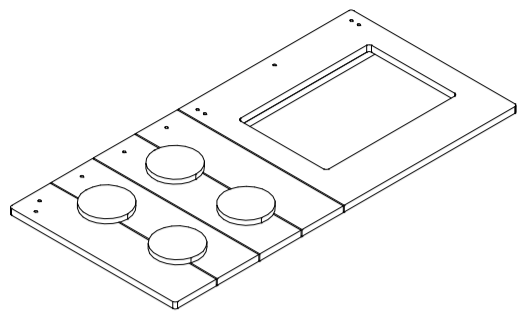

① X 1

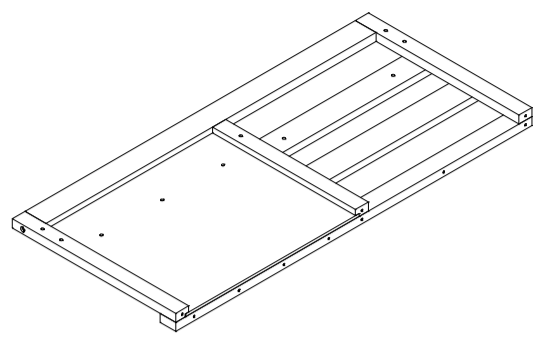

② X 1

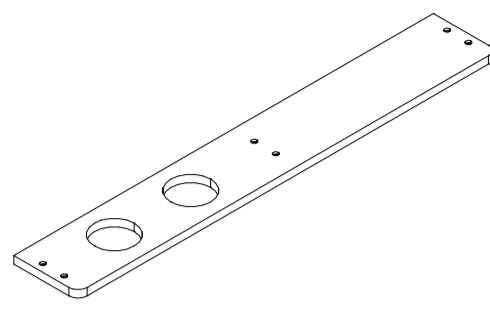

③ X 1

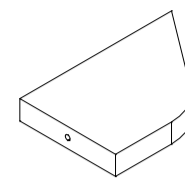

④ X 3

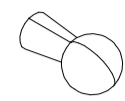

⑤ X 5

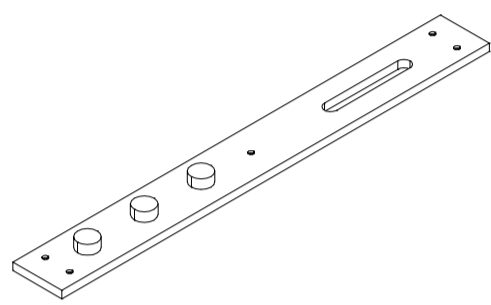

⑥ X 1

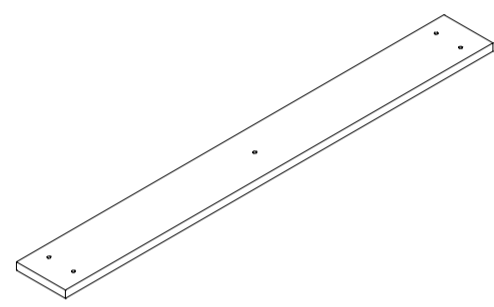

⑦ X 1

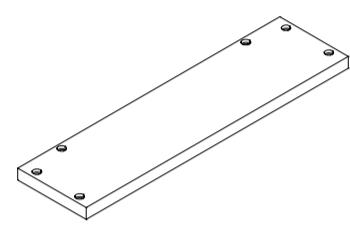

⑧ X 2

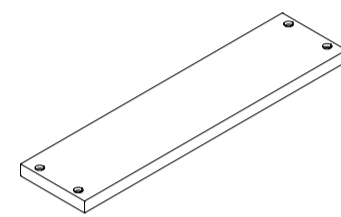

⑨ X 3

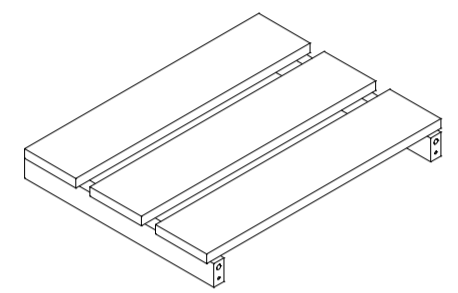

⑩ X 1

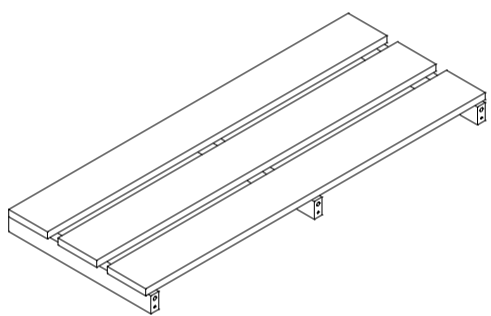

⑪ X 1

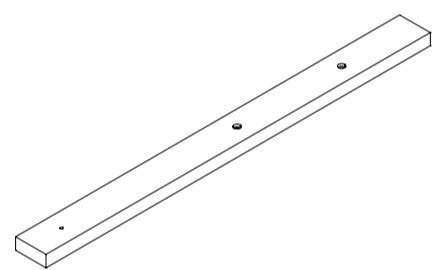

⑫ X 2

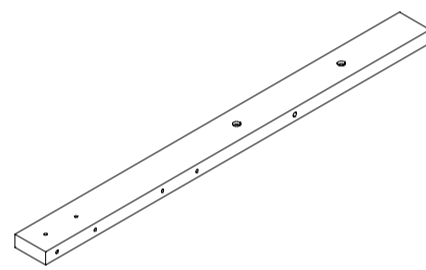

⑬ X 1

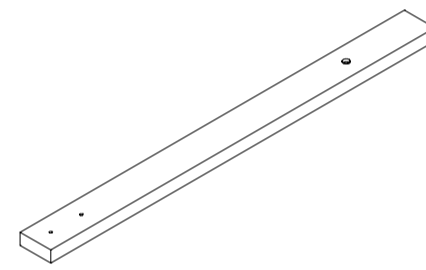

⑭ X 1

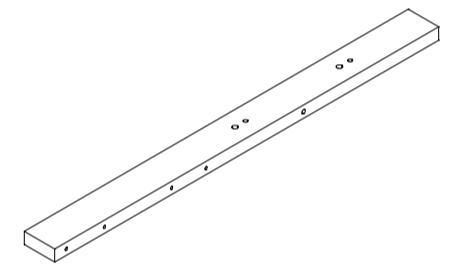

⑮ X 1

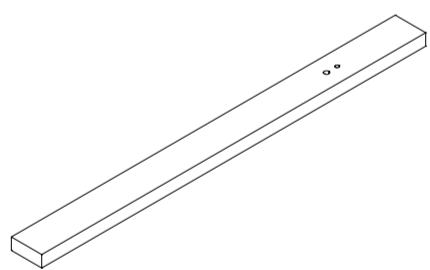

⑯ X 1

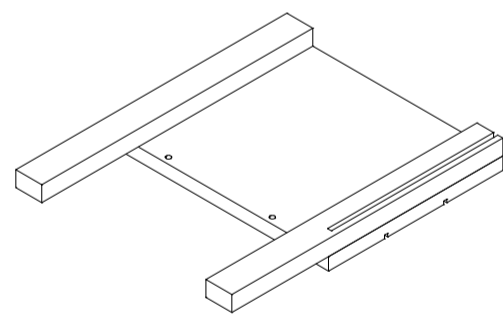

⑰ X 1

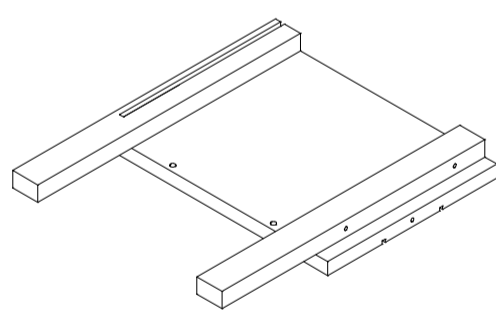

⑱ X 1

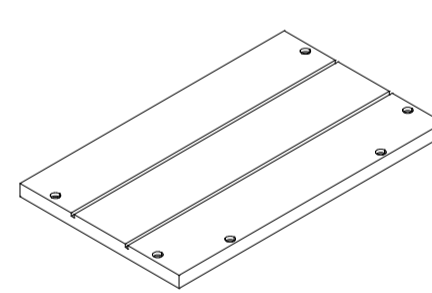

⑲ X 1

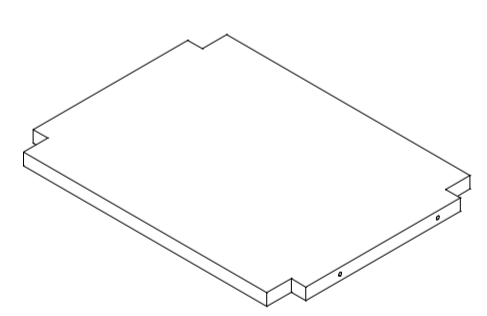

⑳ X 1

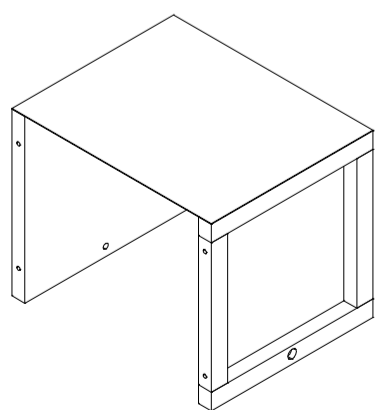

㉑ X 1

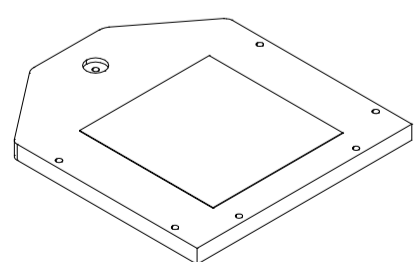

㉒ X 1

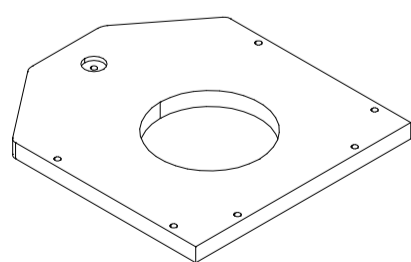

㉓ X 1

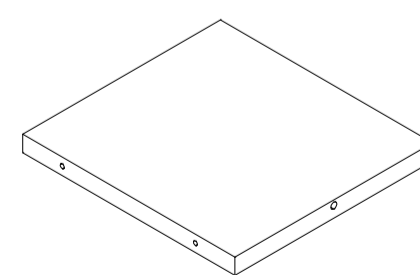

㉔ X 1

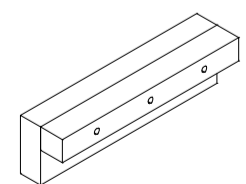

㉕ X 1

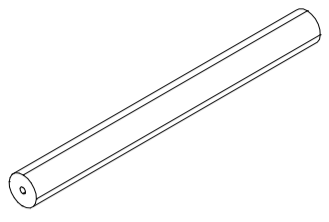

26 X 1

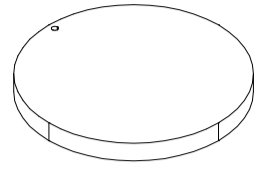

27 X 1

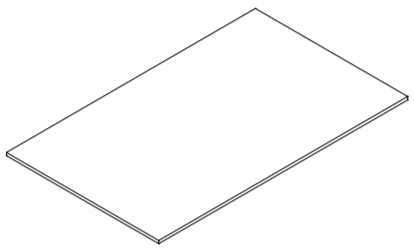

28 X 1

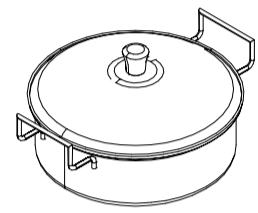

29 X 1

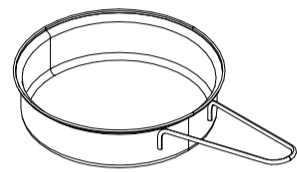

30 X 1

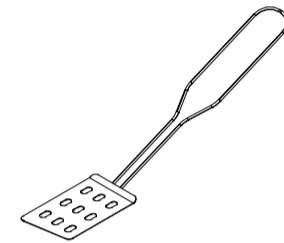

31 X 1

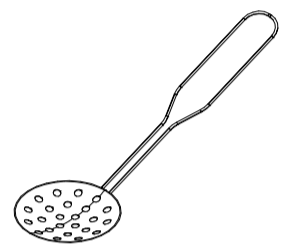

32 X 1

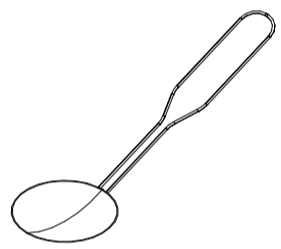

33 X 1

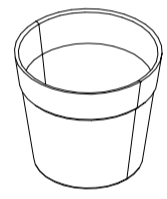

34 X 2

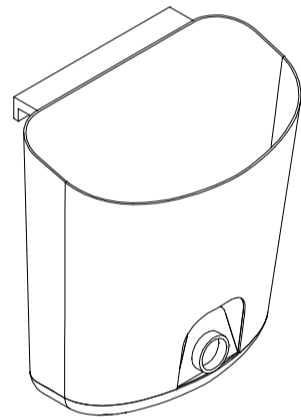

35 X 1

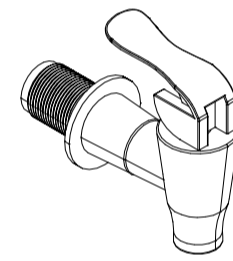

36 X 1

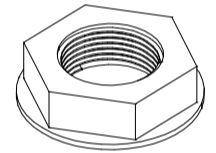

37 X 1

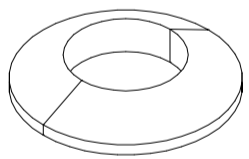

38 X 1

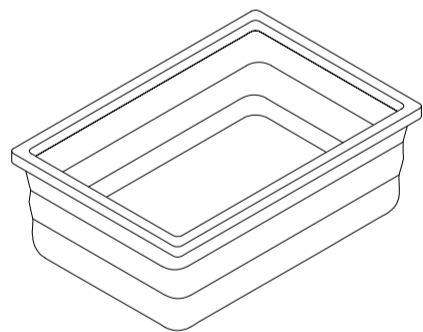

39 X 1

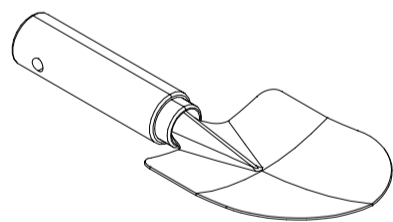

40 X 1

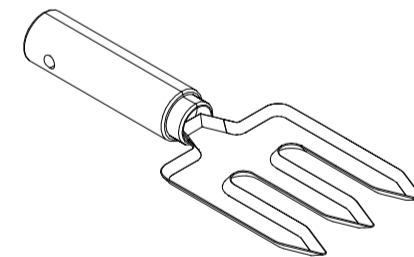

41 X 1

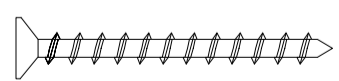

A x 67

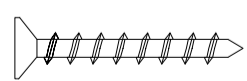

B x 15

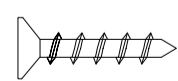

C x 18

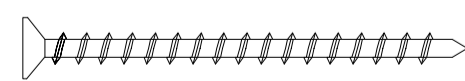

D x 2

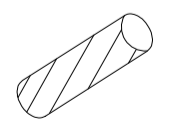

E x 10

1

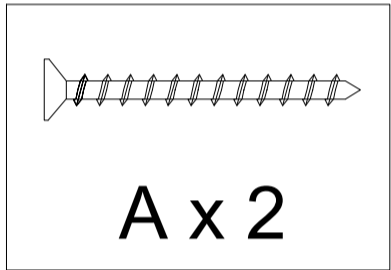
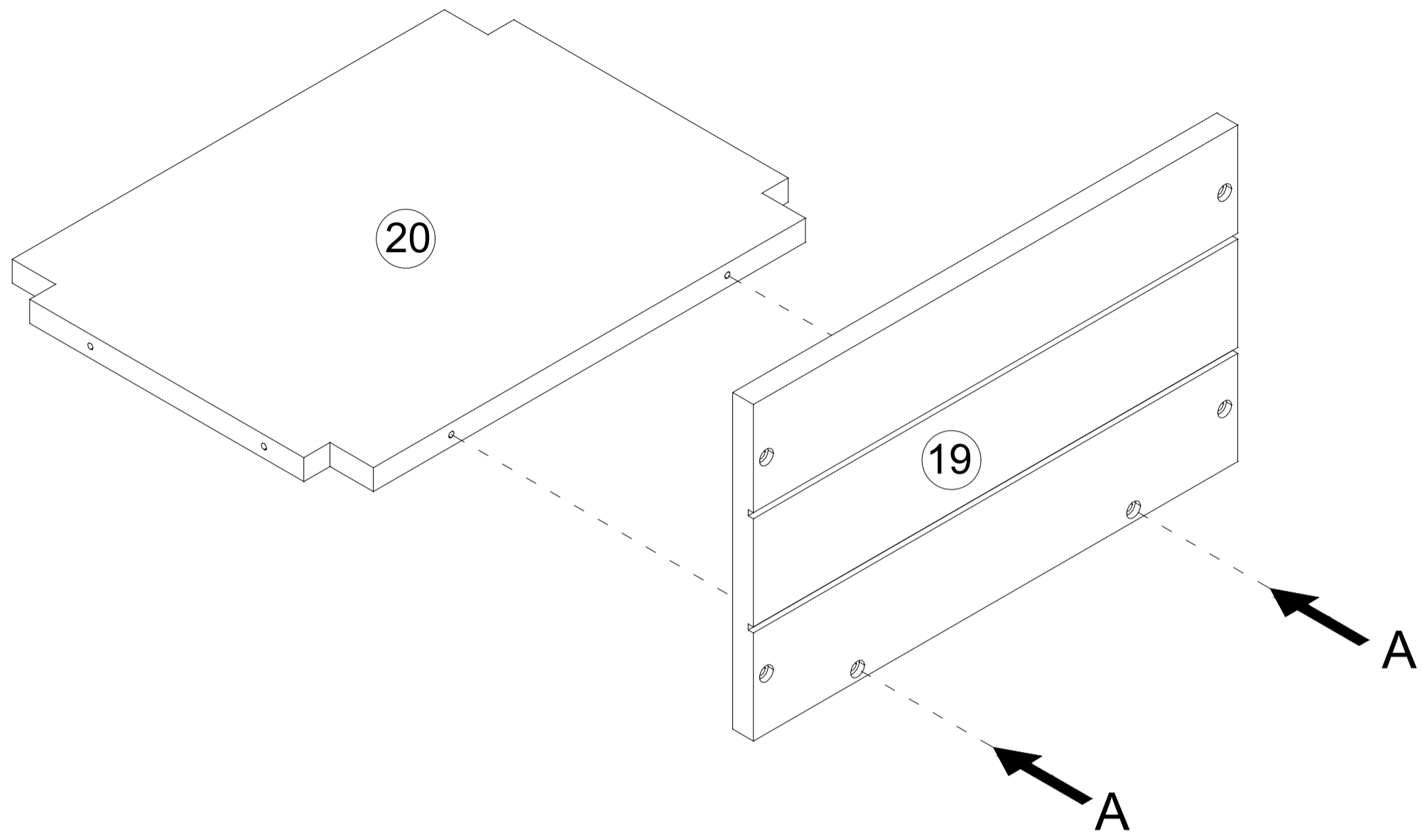

2

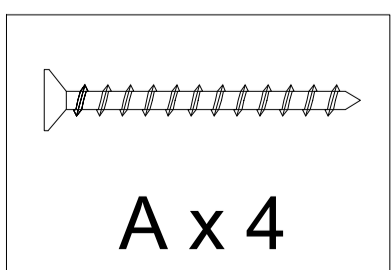
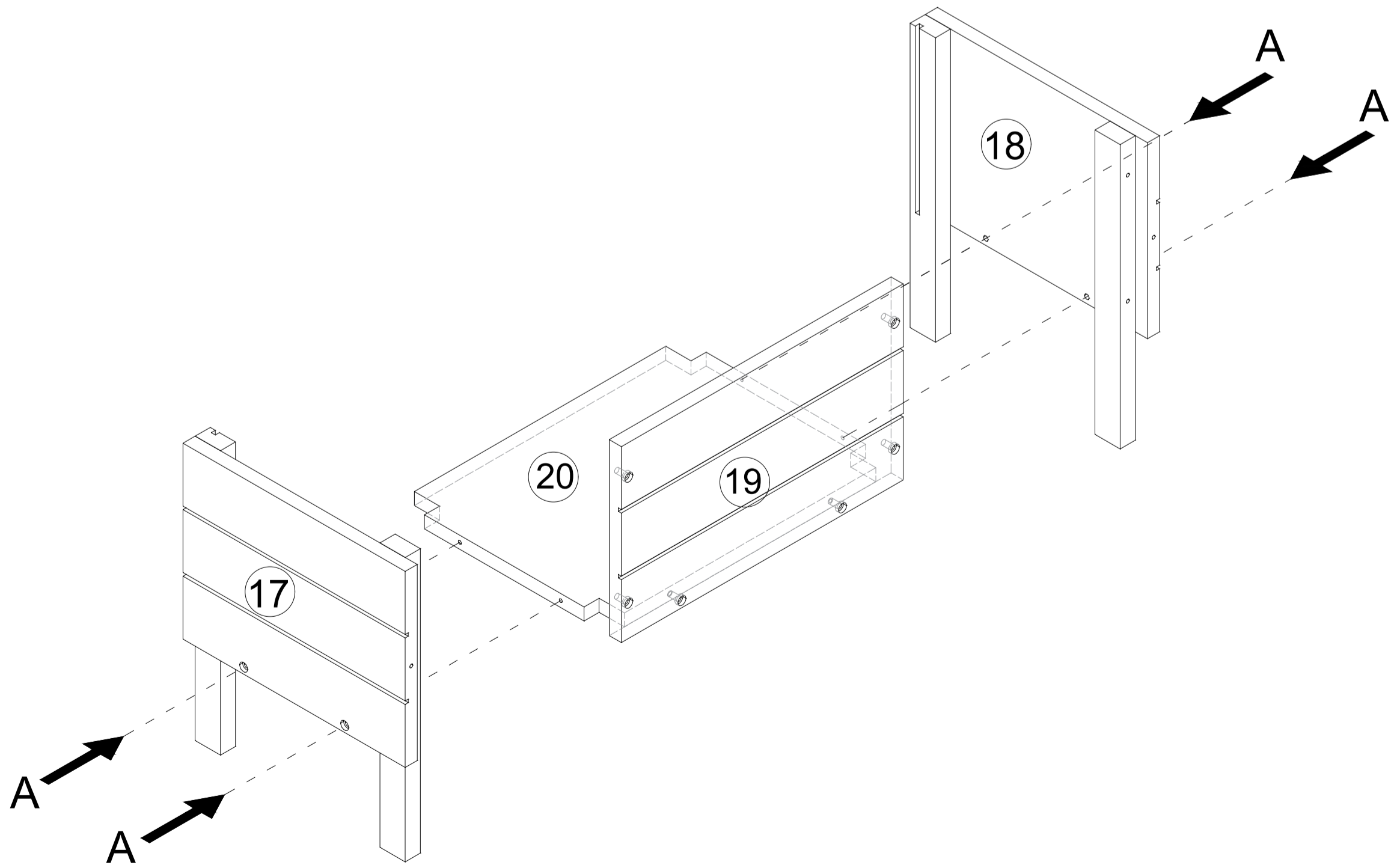

3

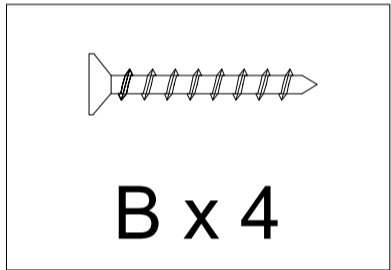
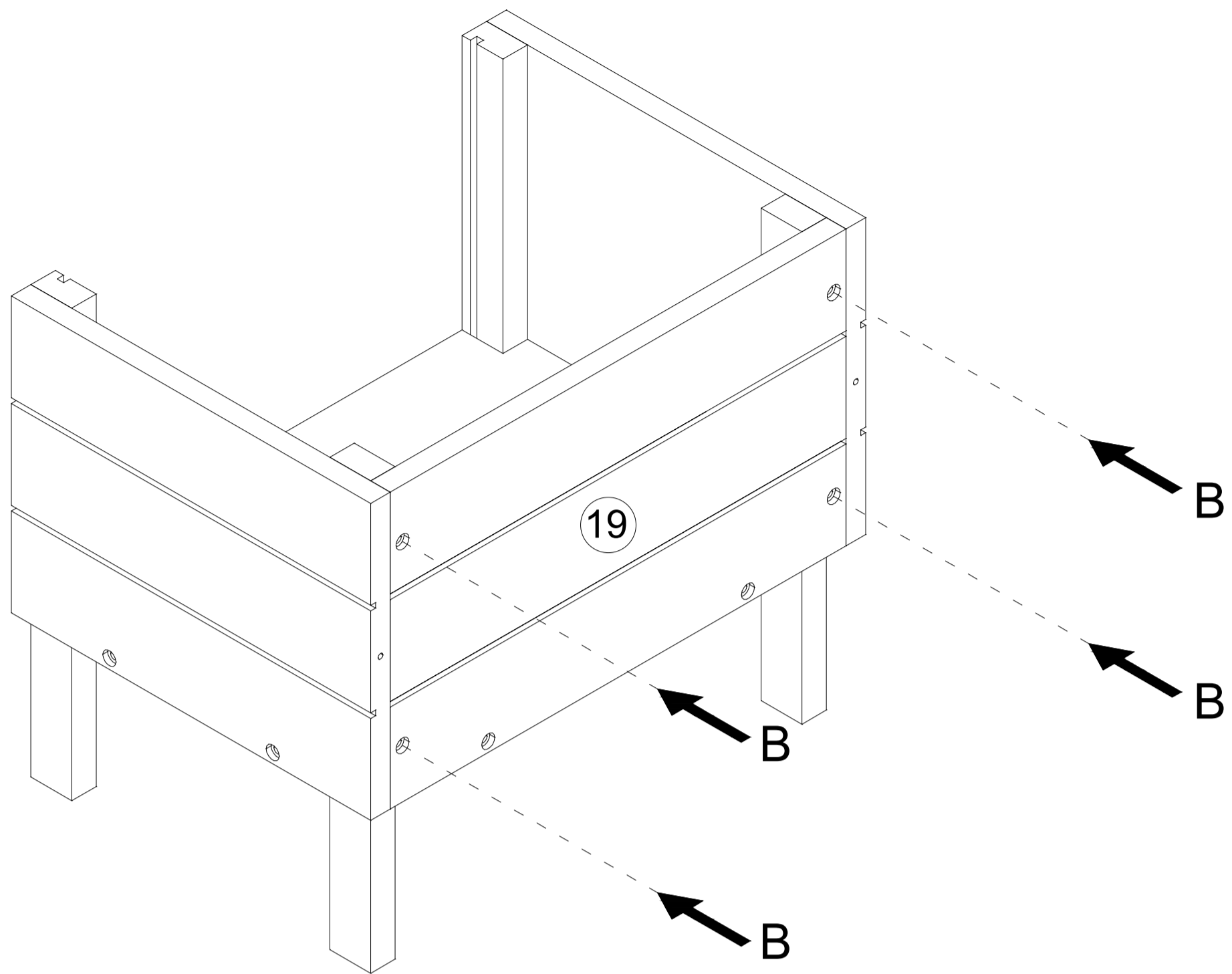

4

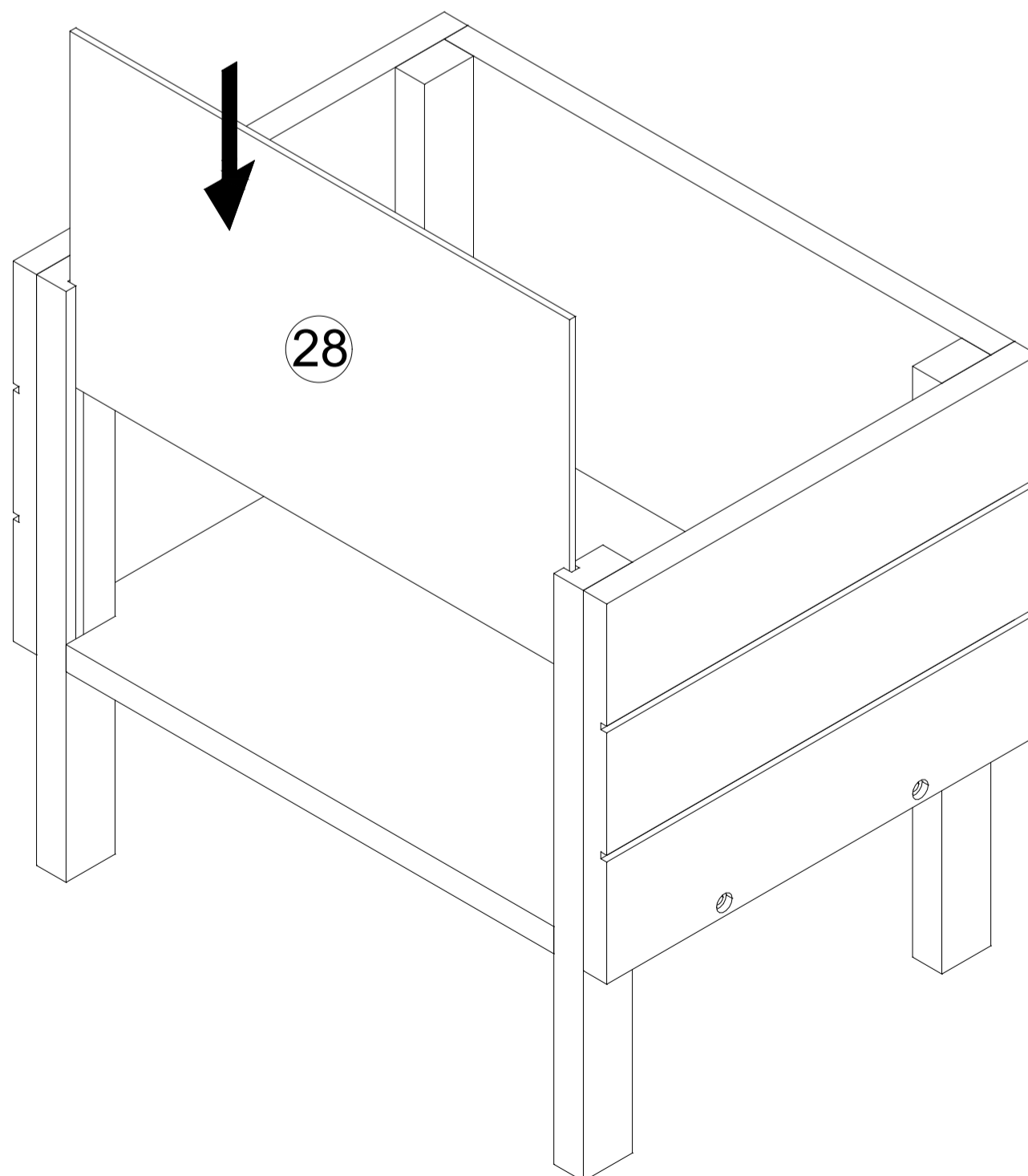

5

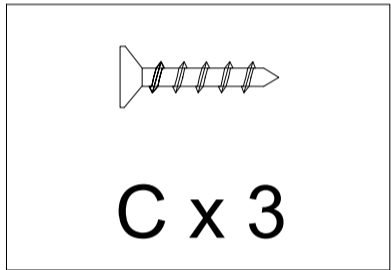
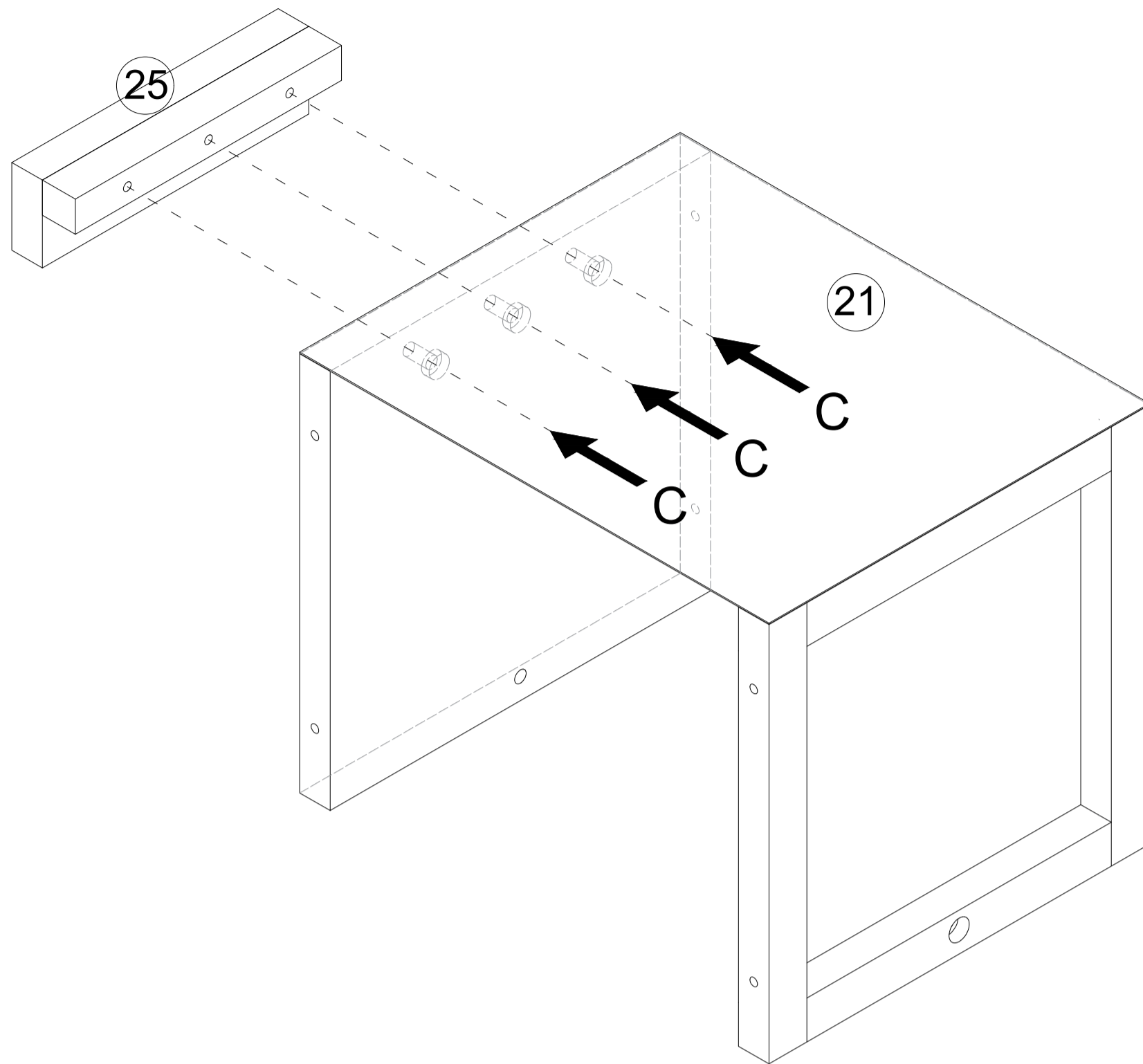

6

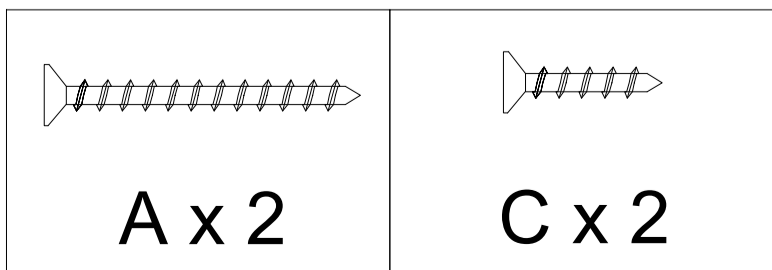
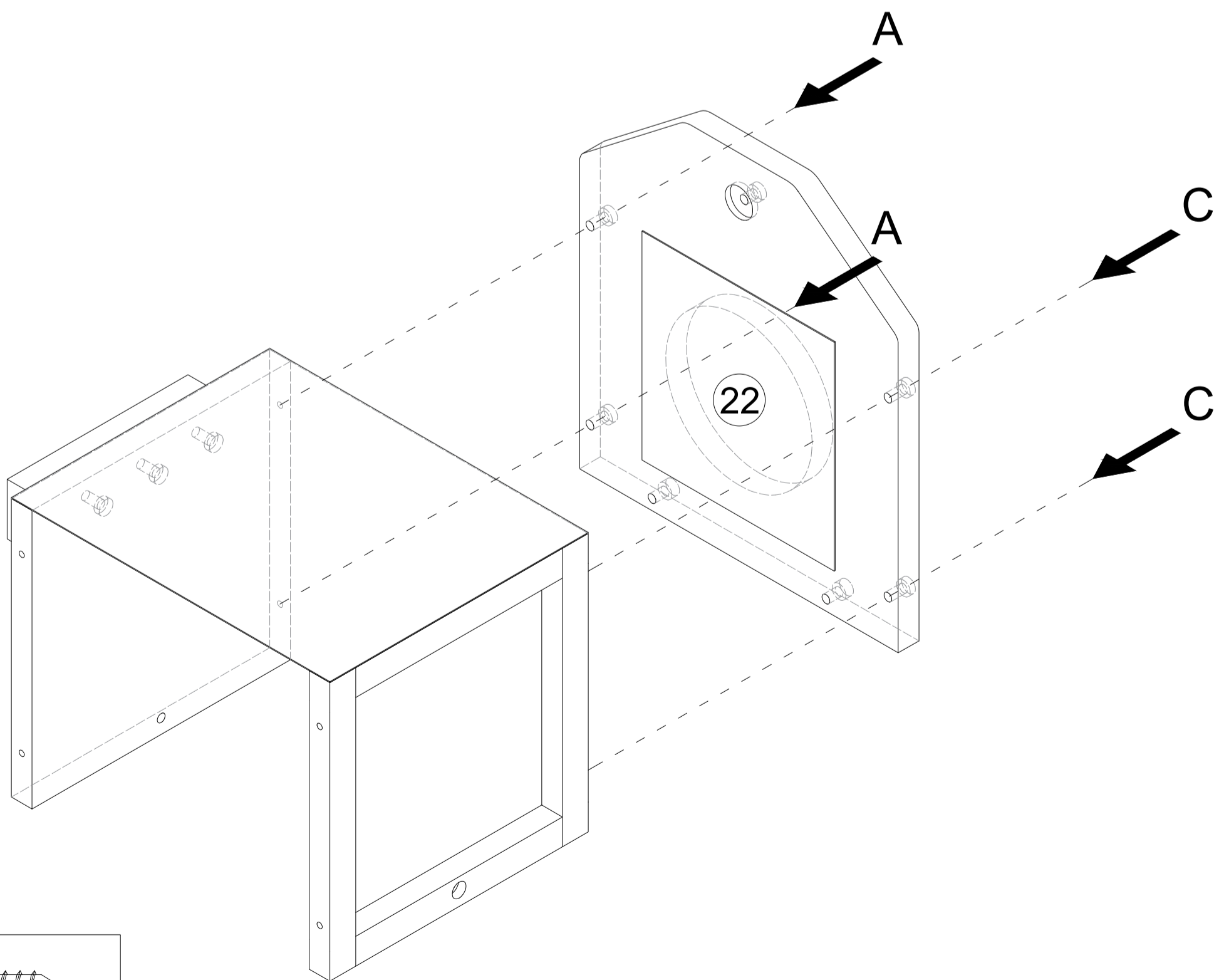

7

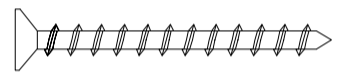
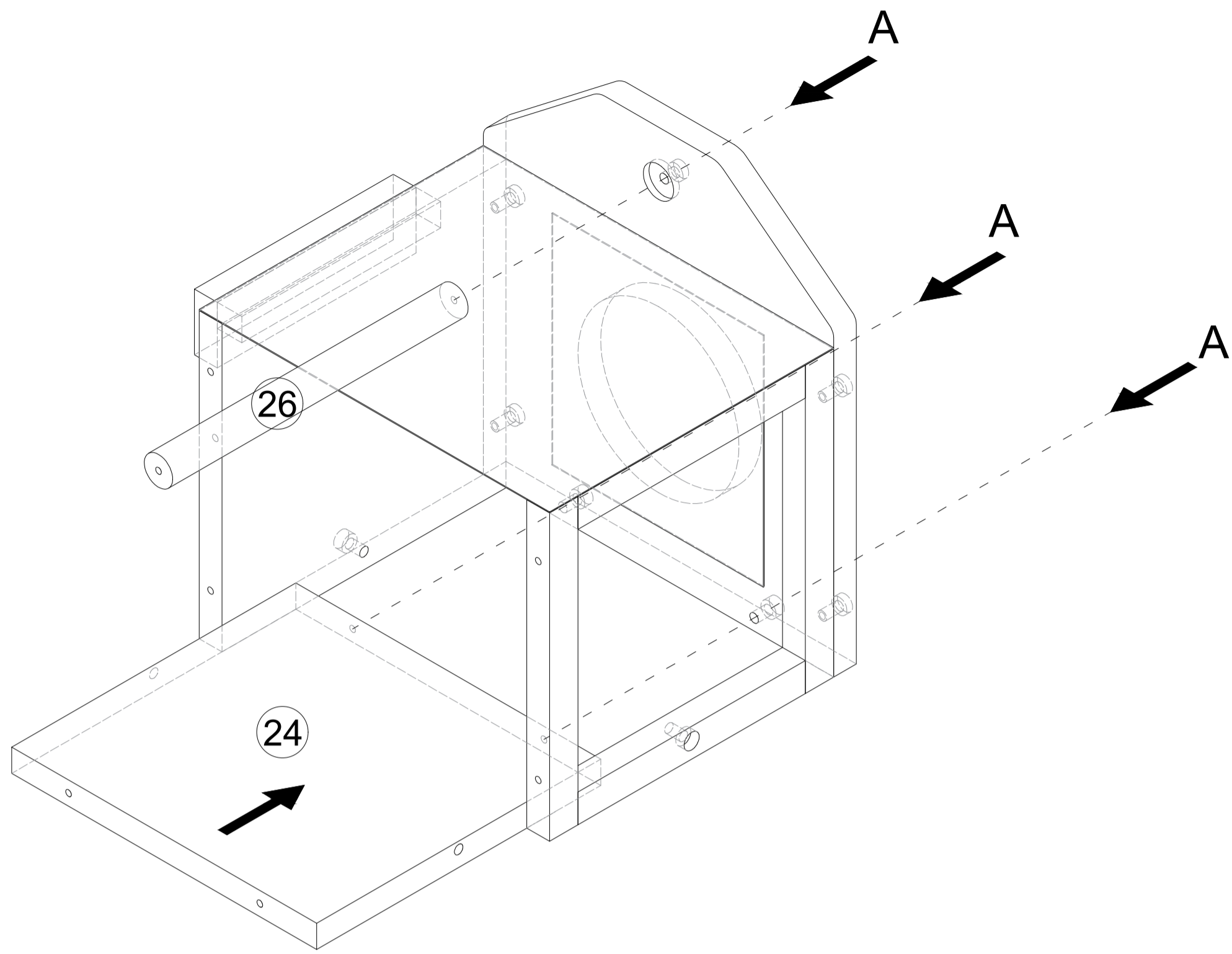

A x 3

8

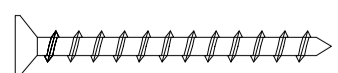
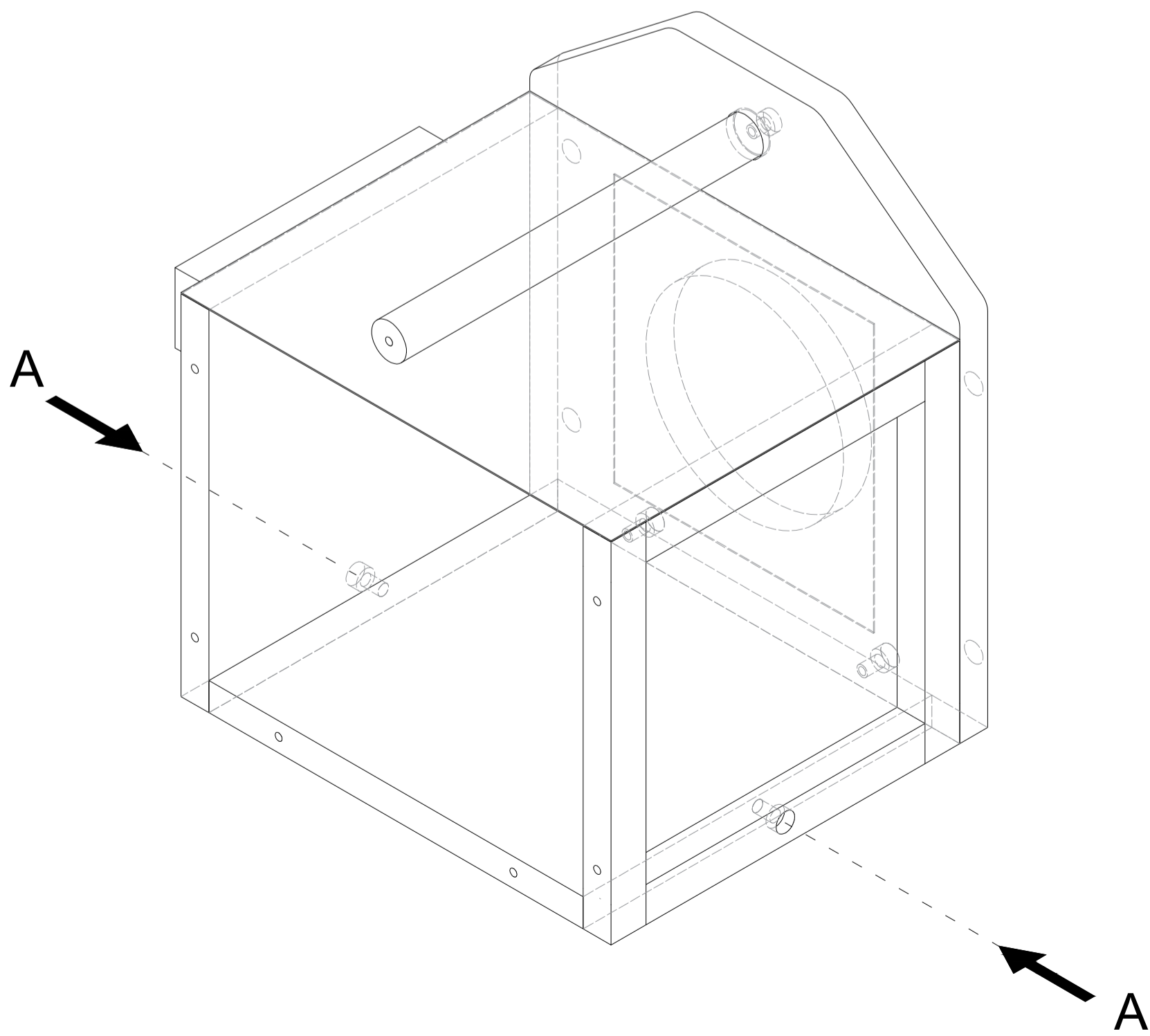

A x 2

9

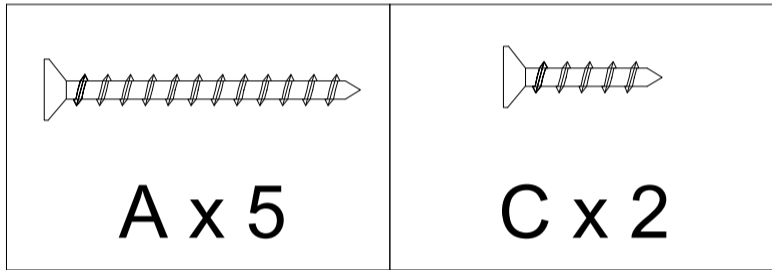
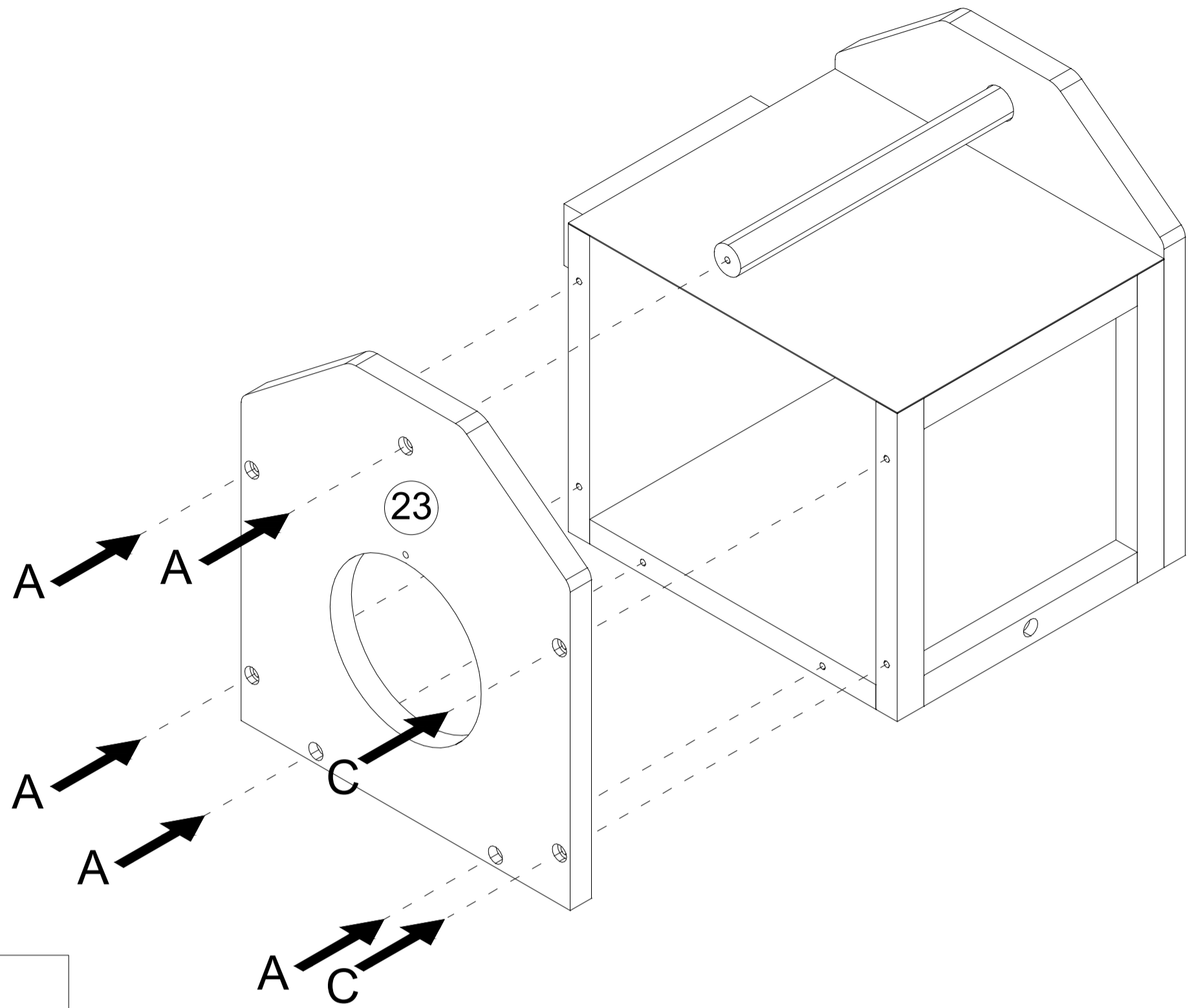

10

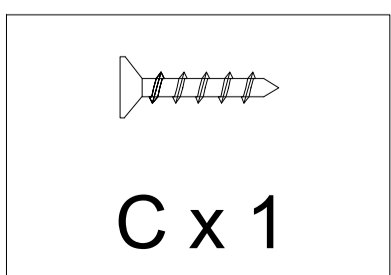
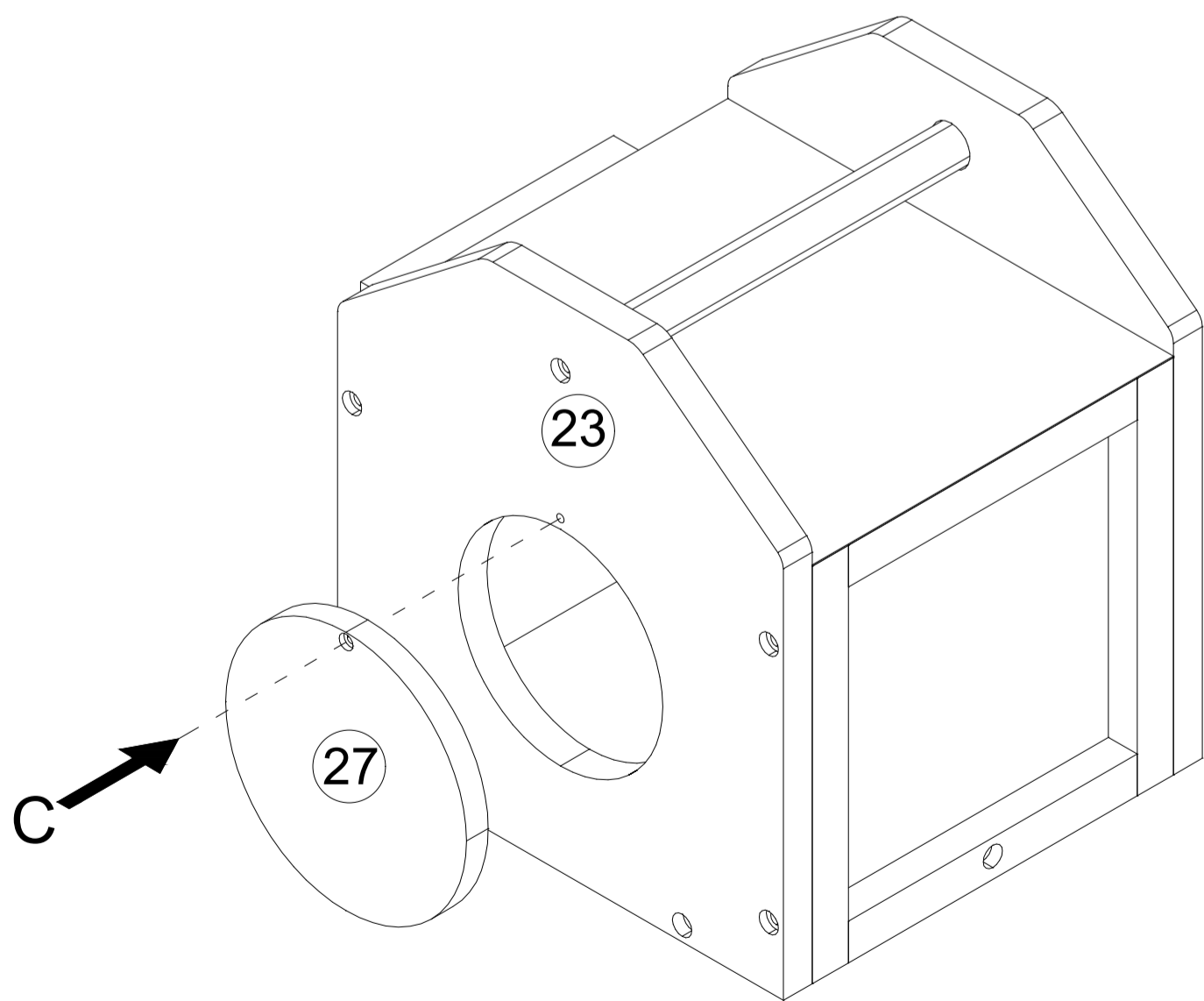

11

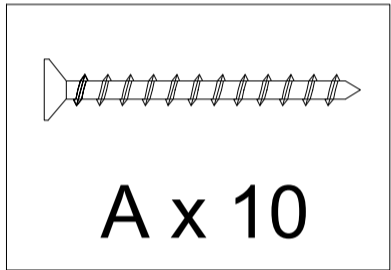
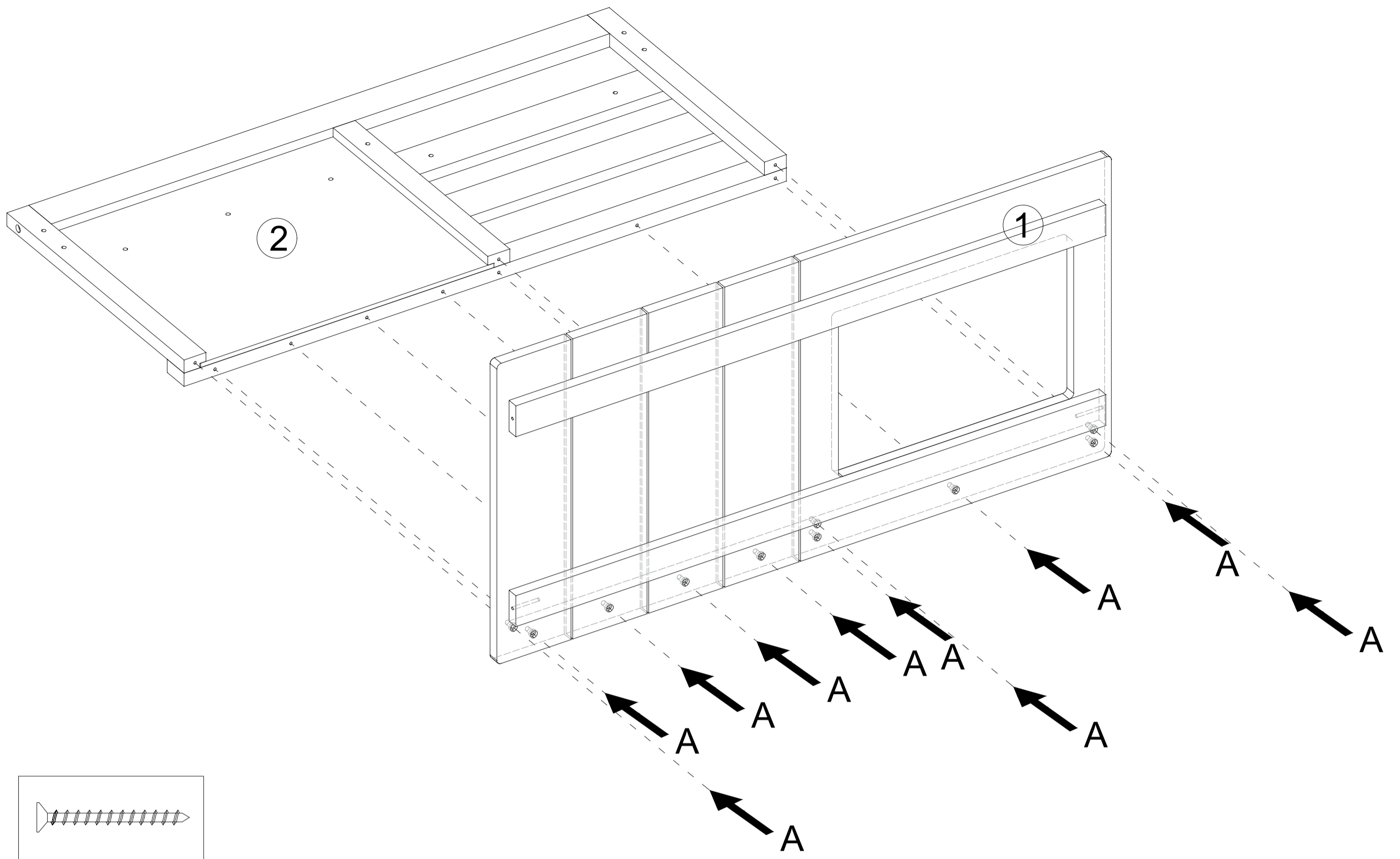

12

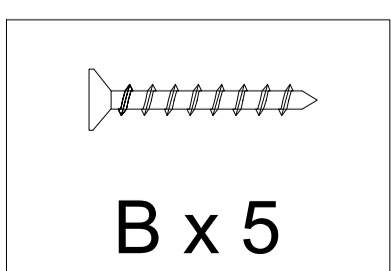
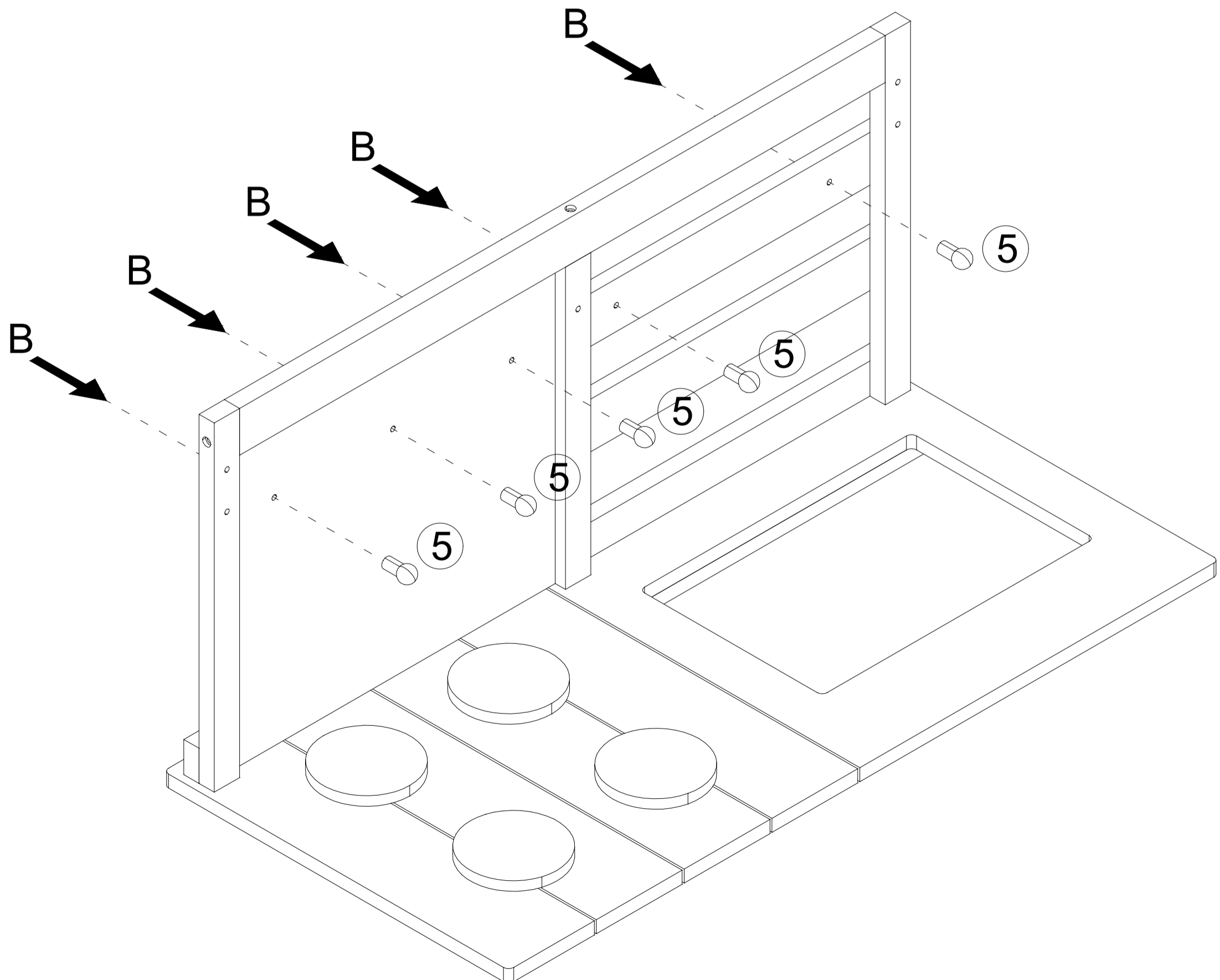

13

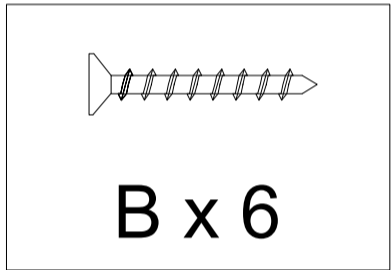
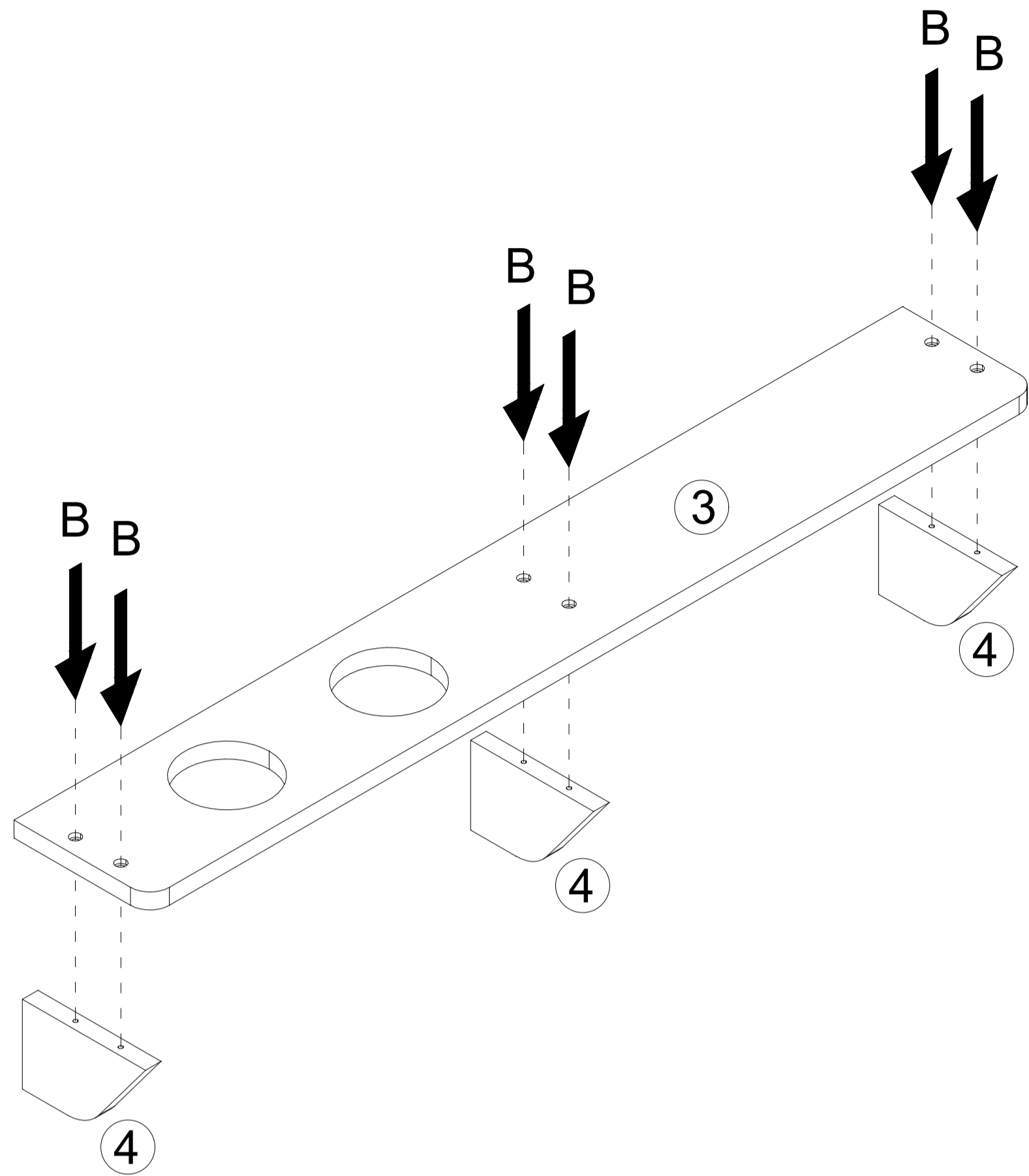

14

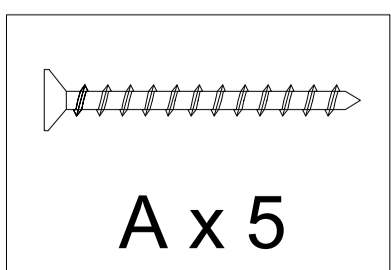
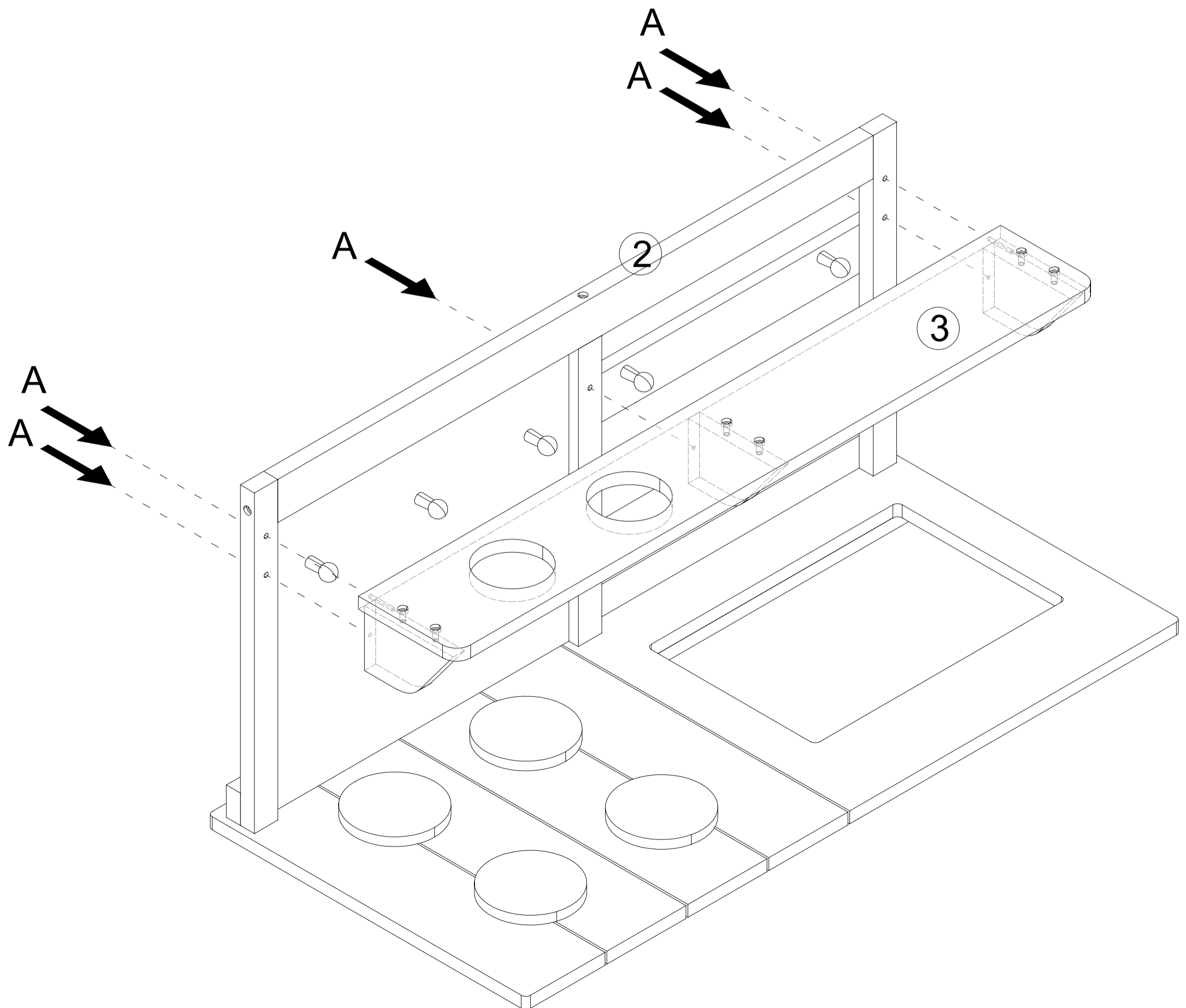

15

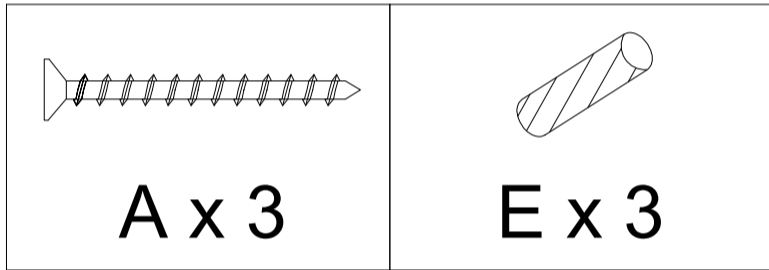
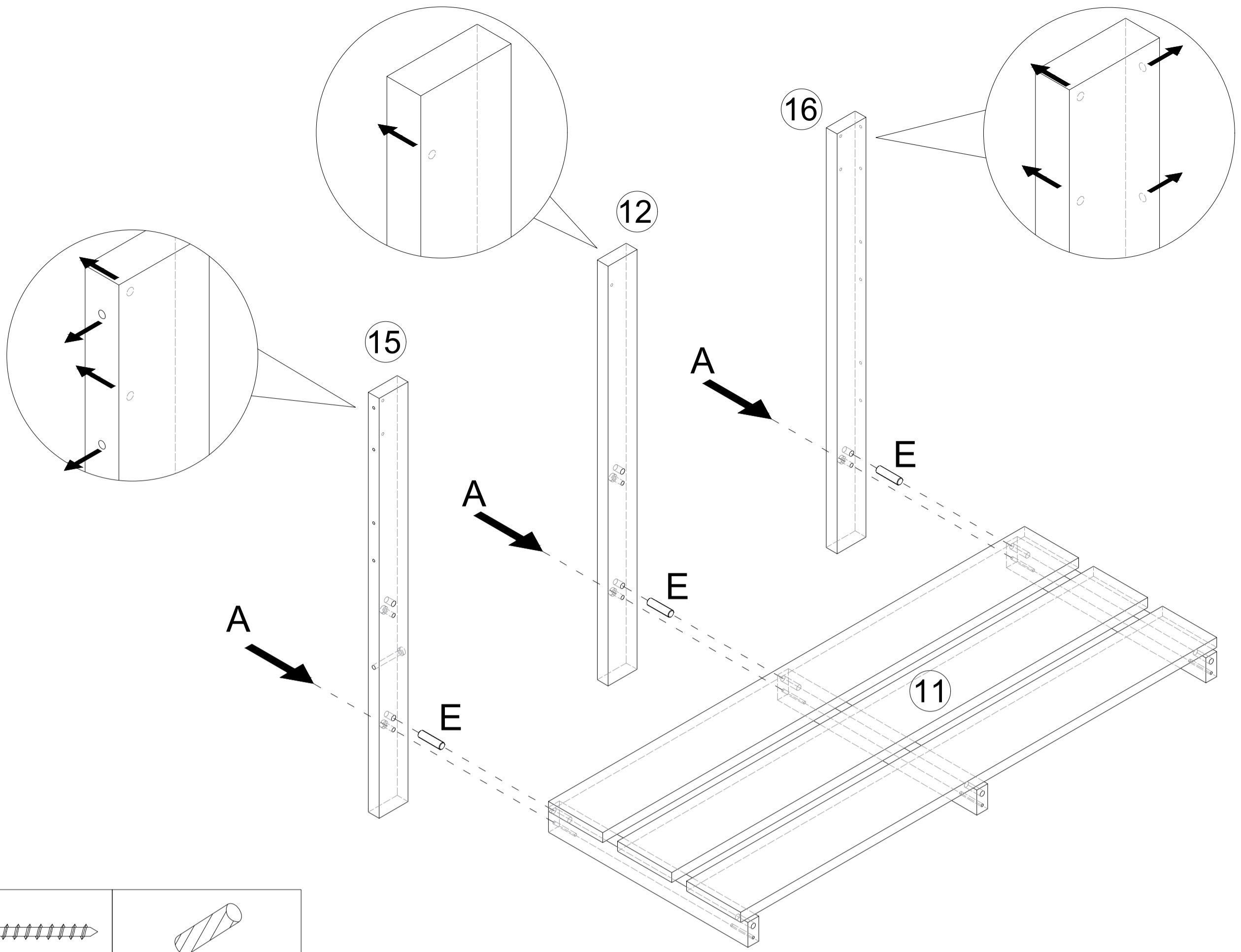

16

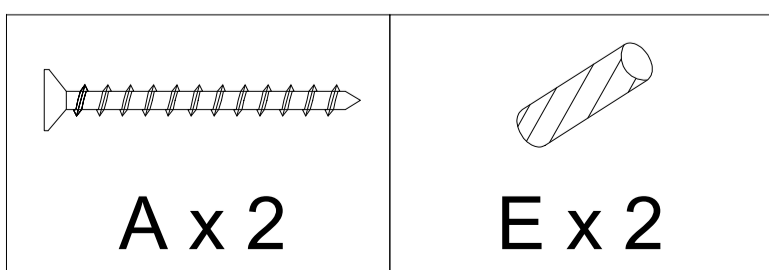
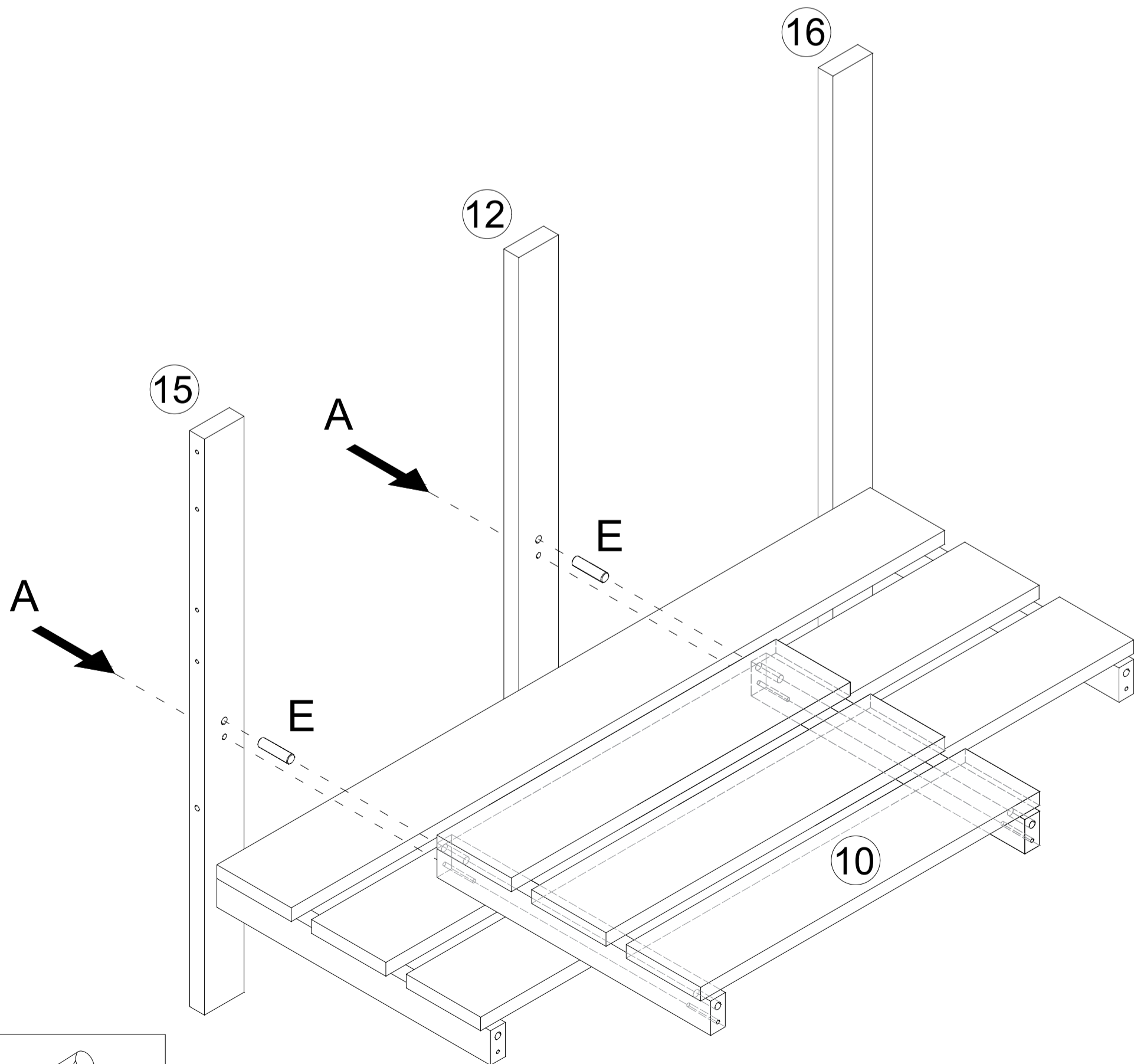

17

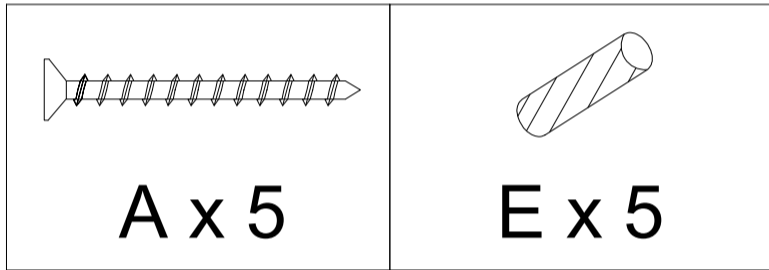
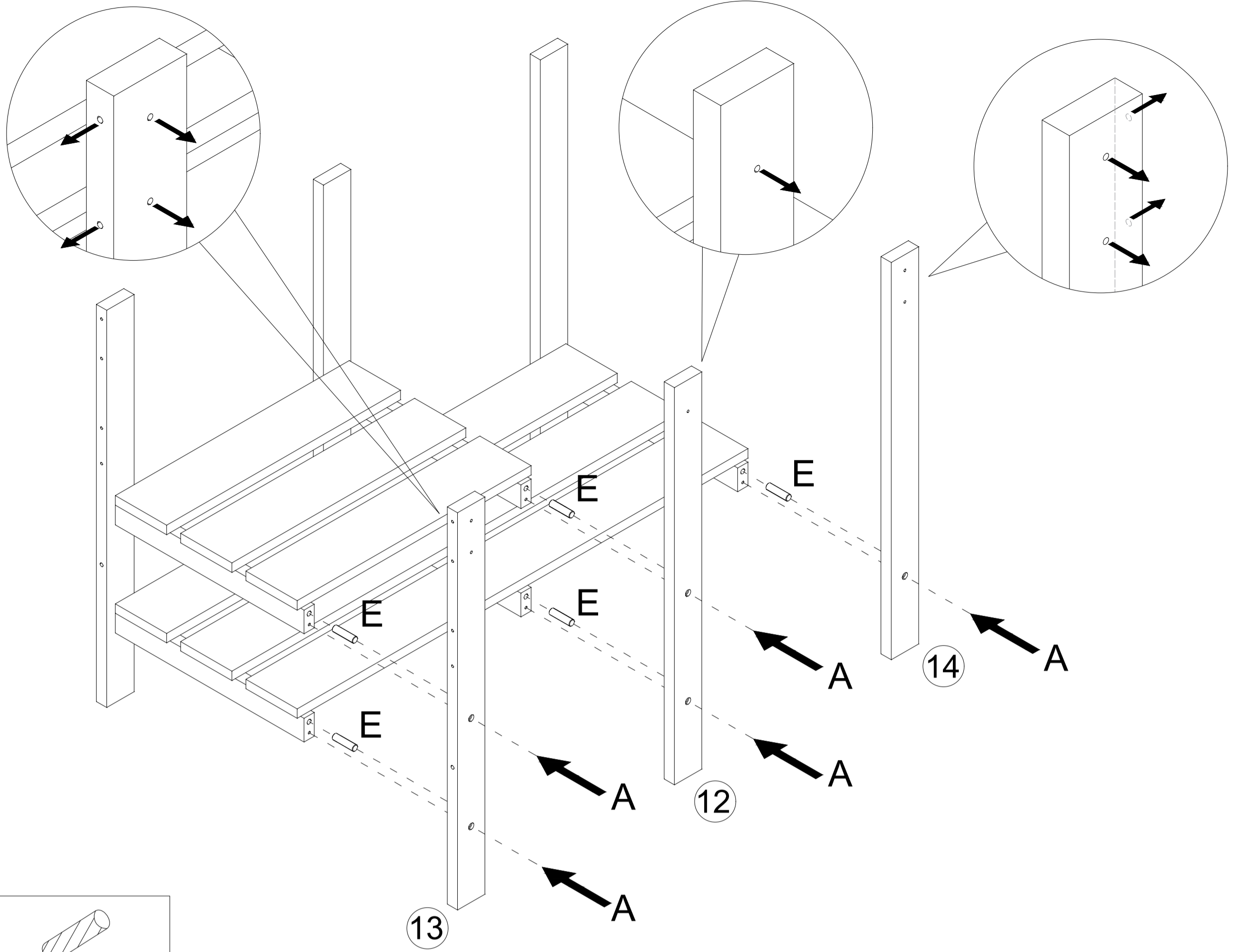

18

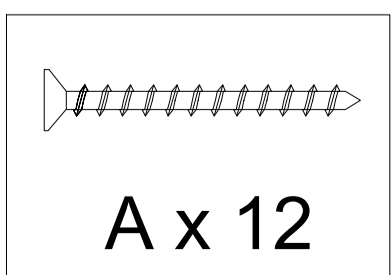
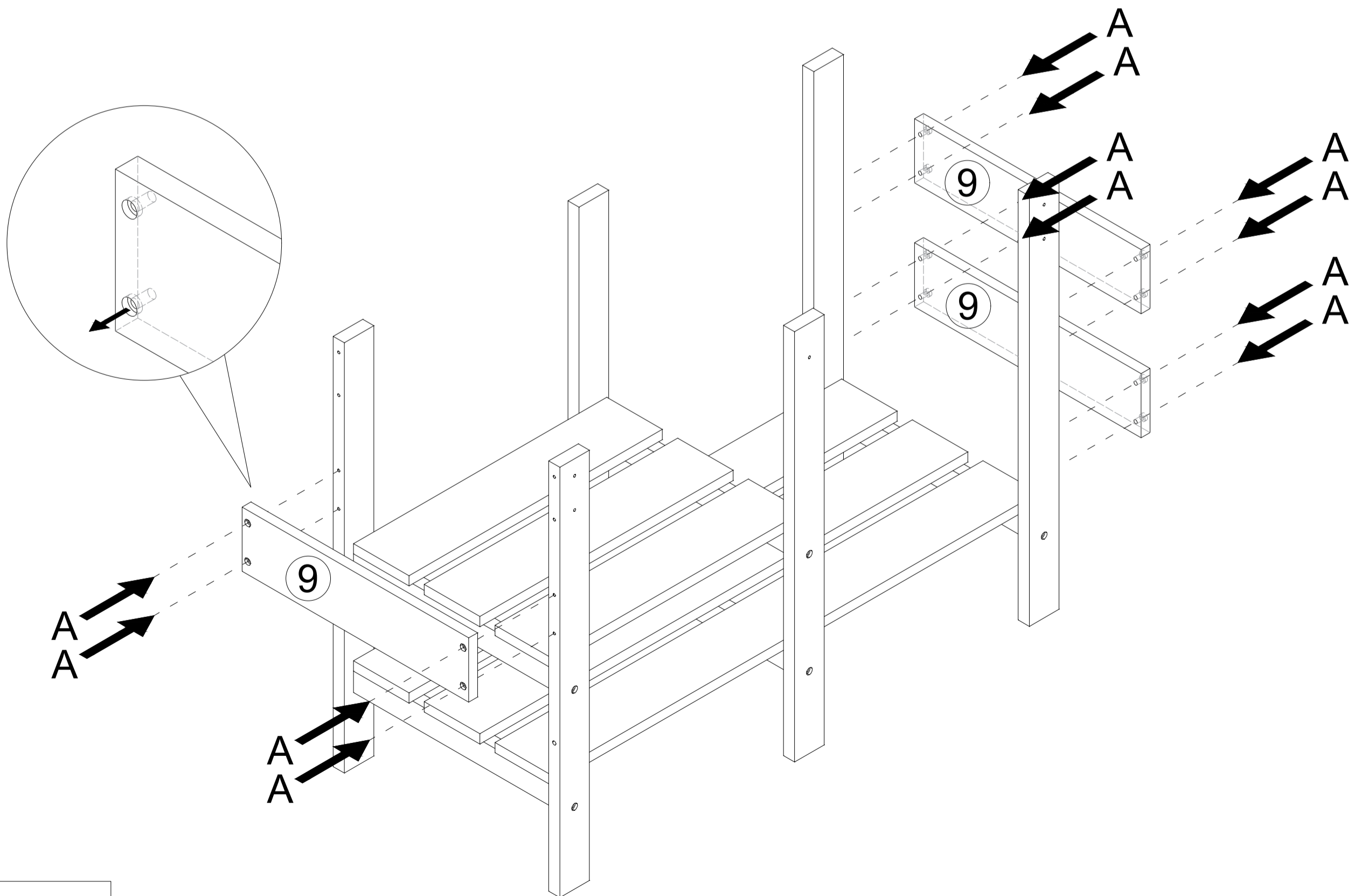

19

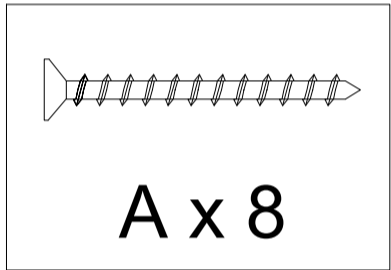
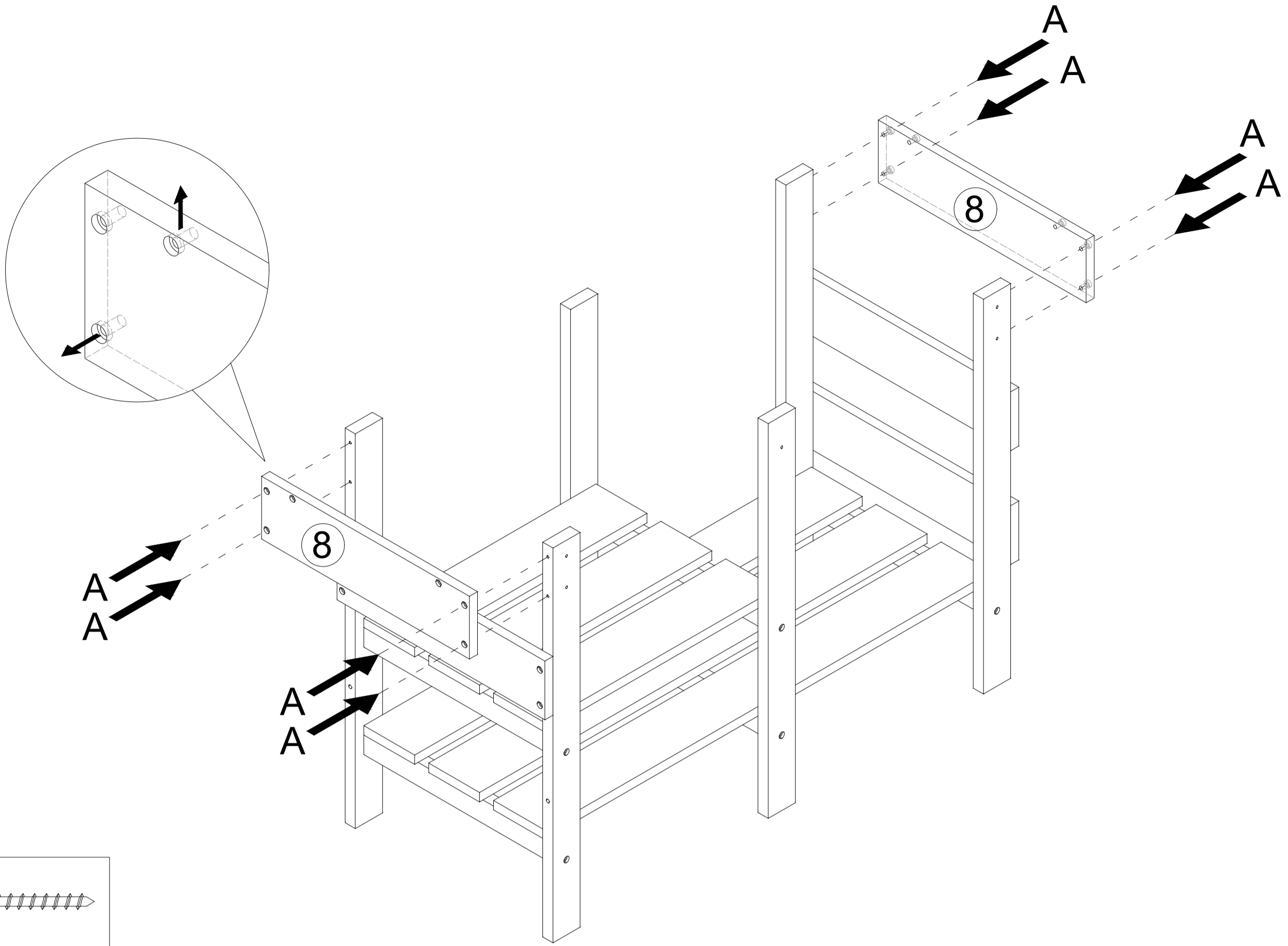

20

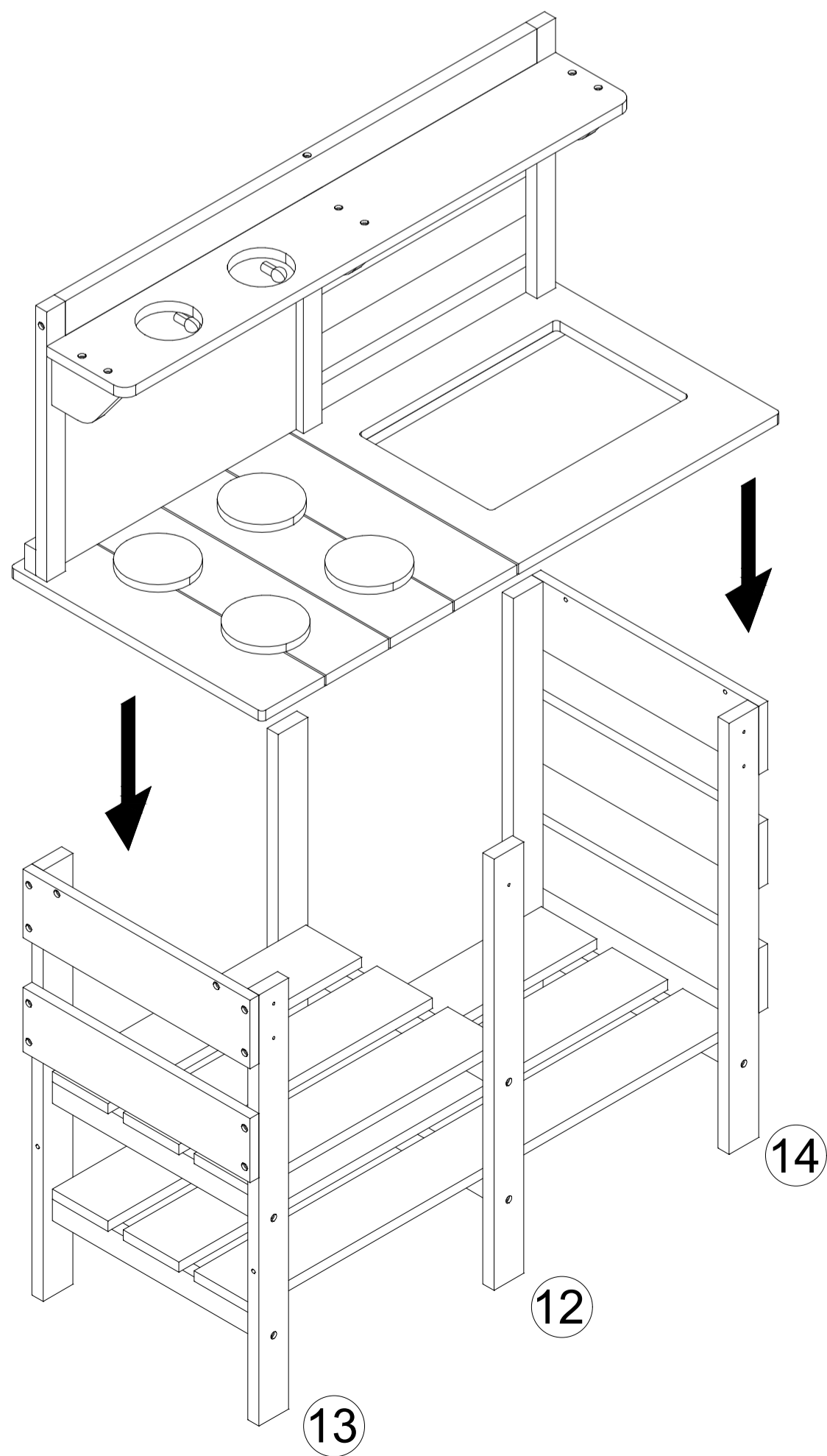

21

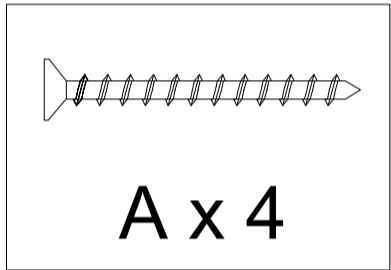
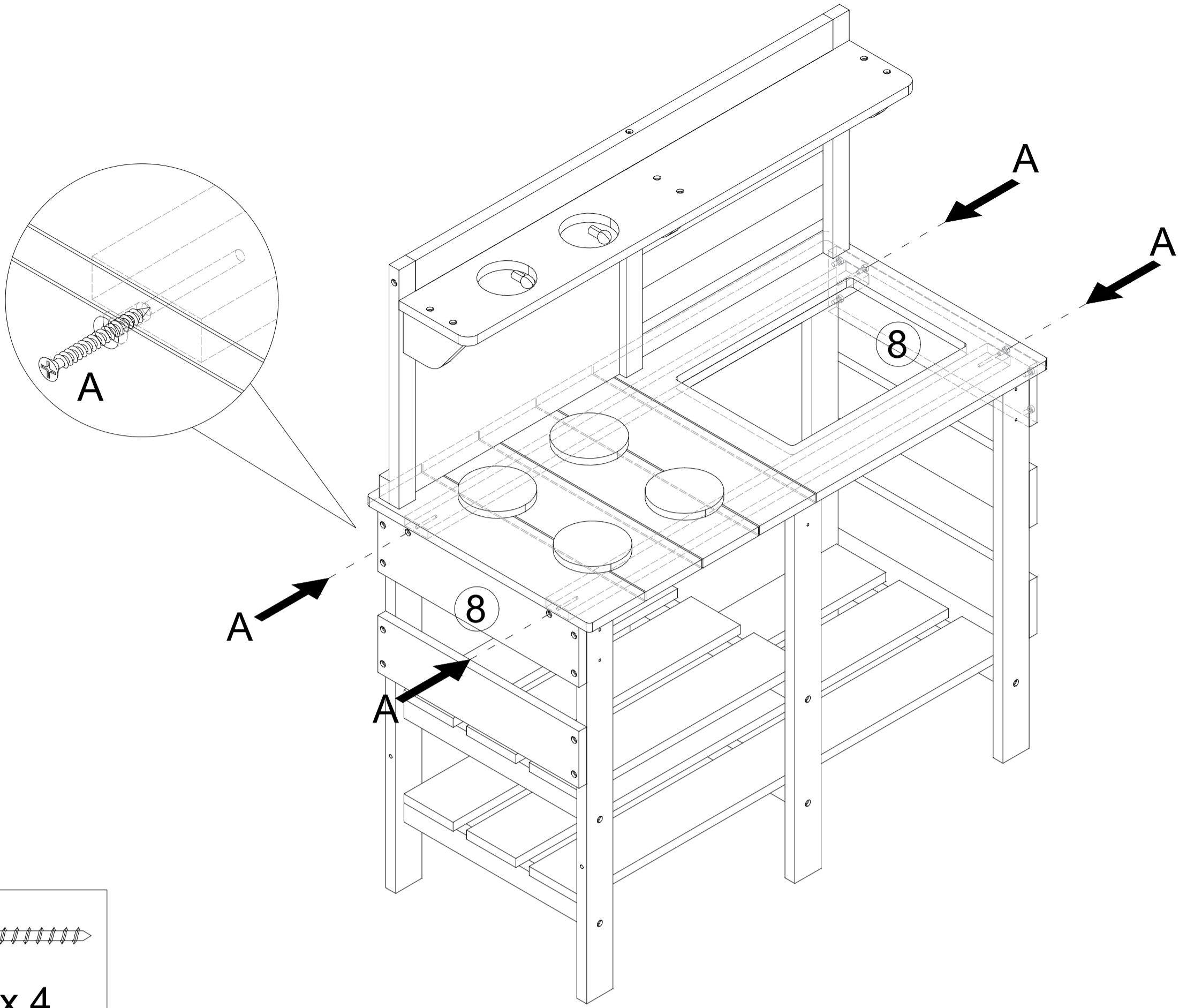

22

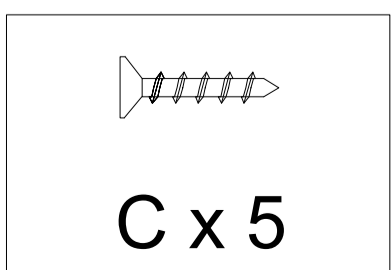
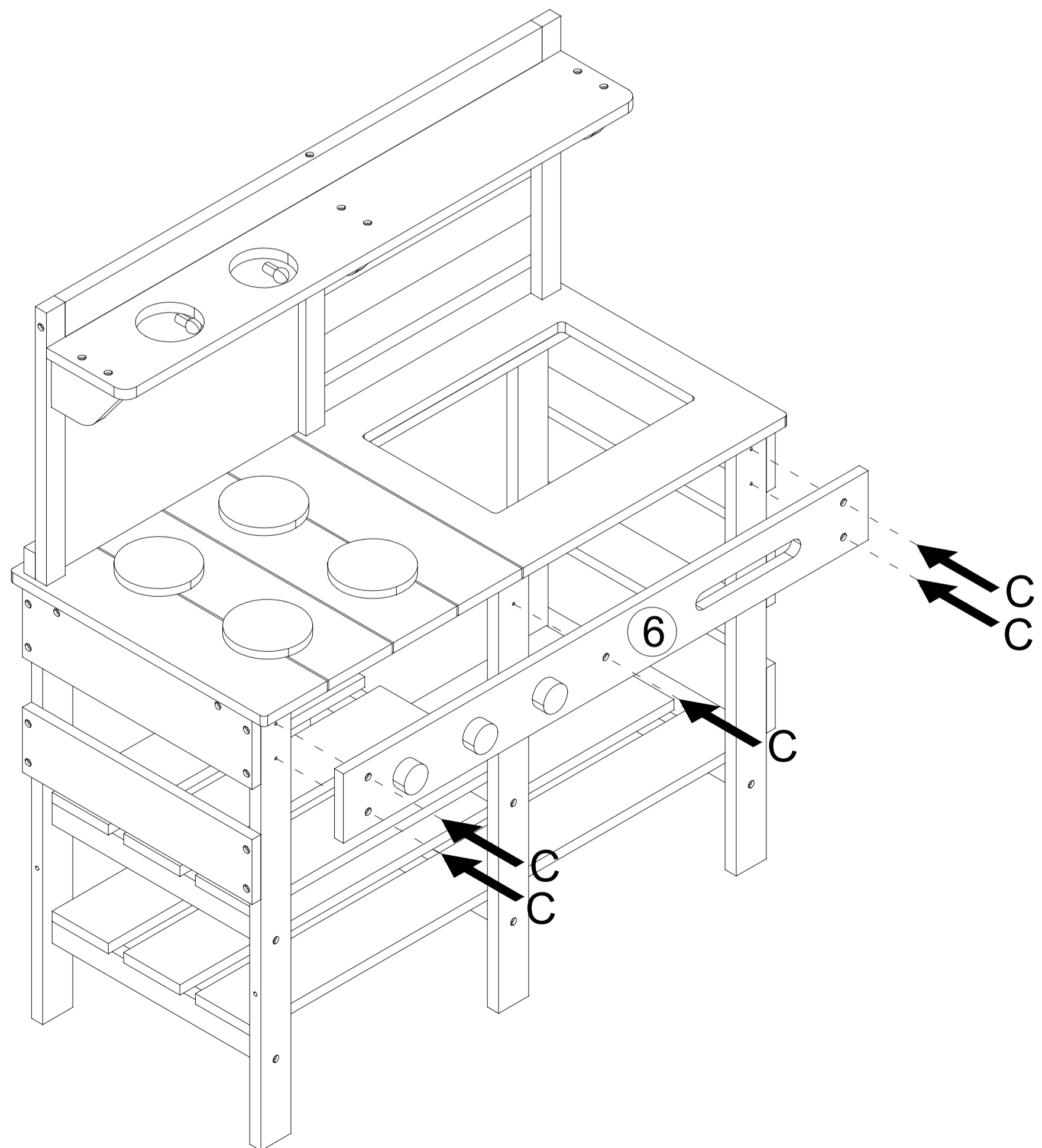

23

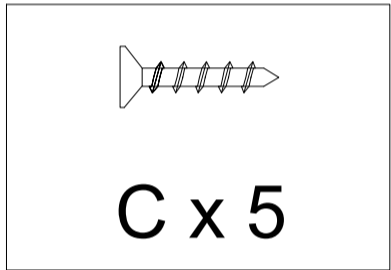
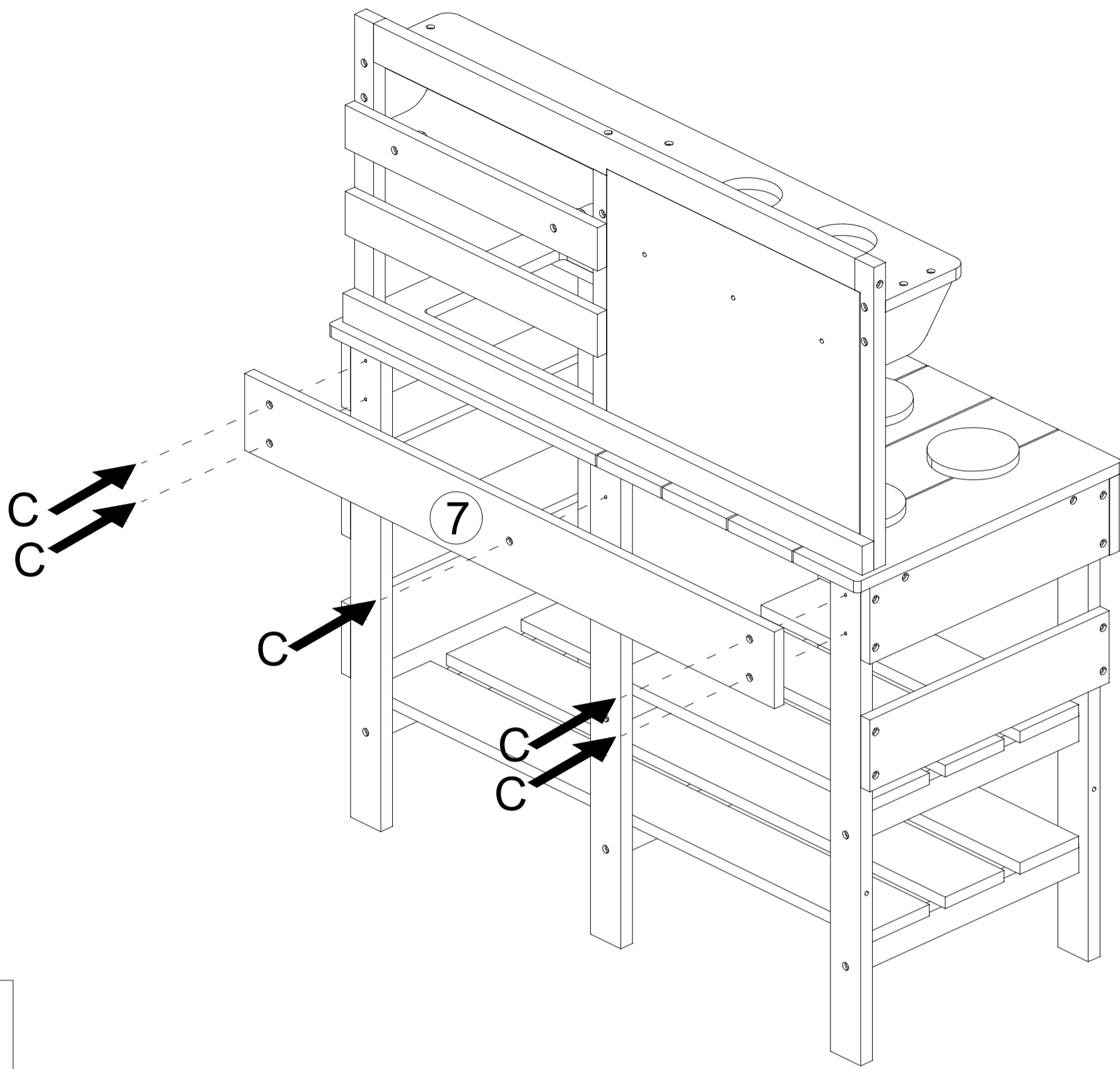

24

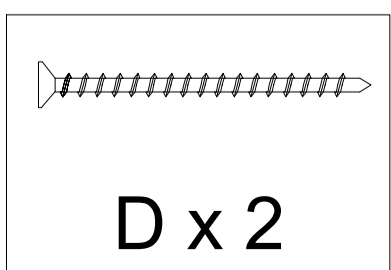
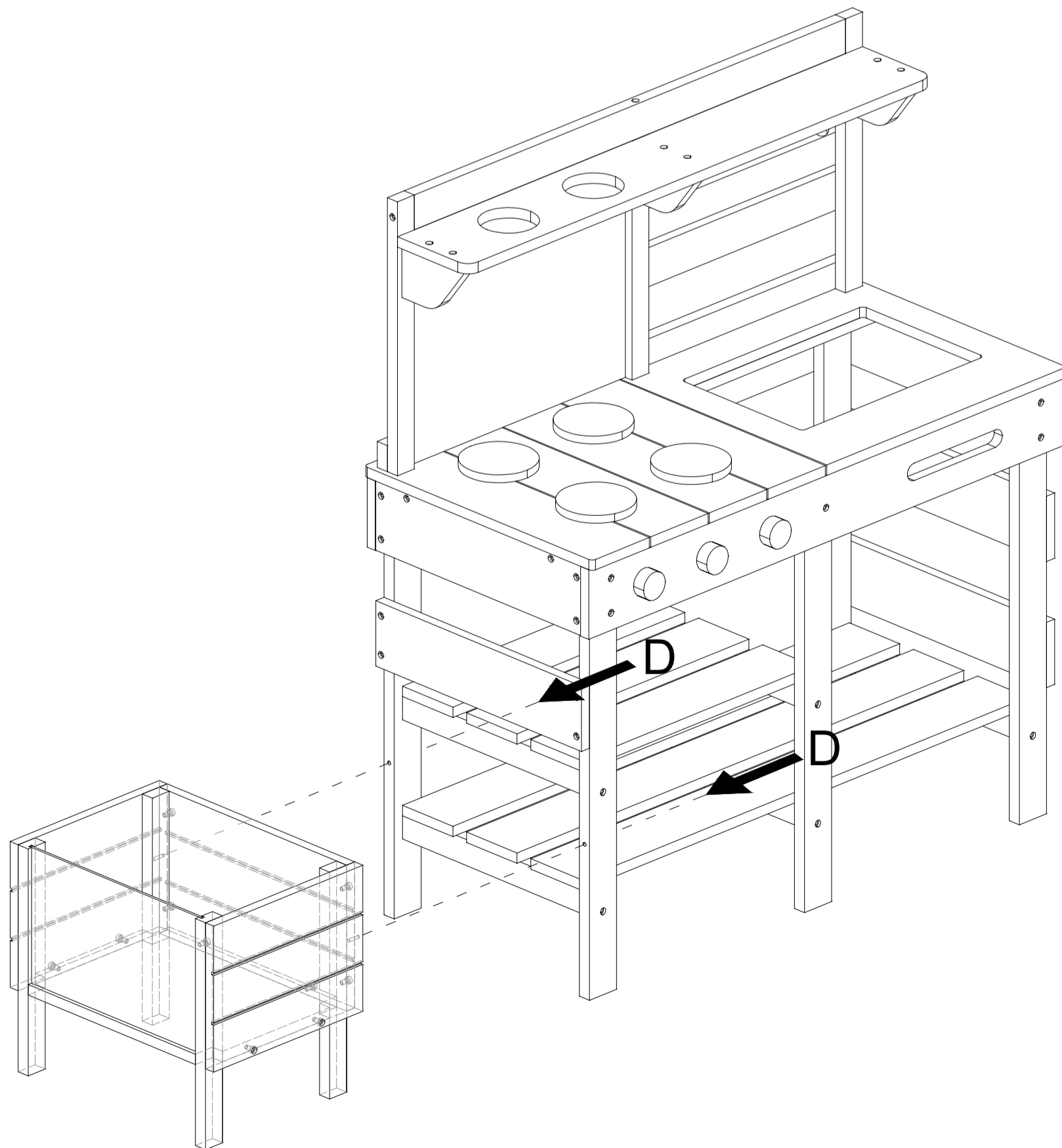

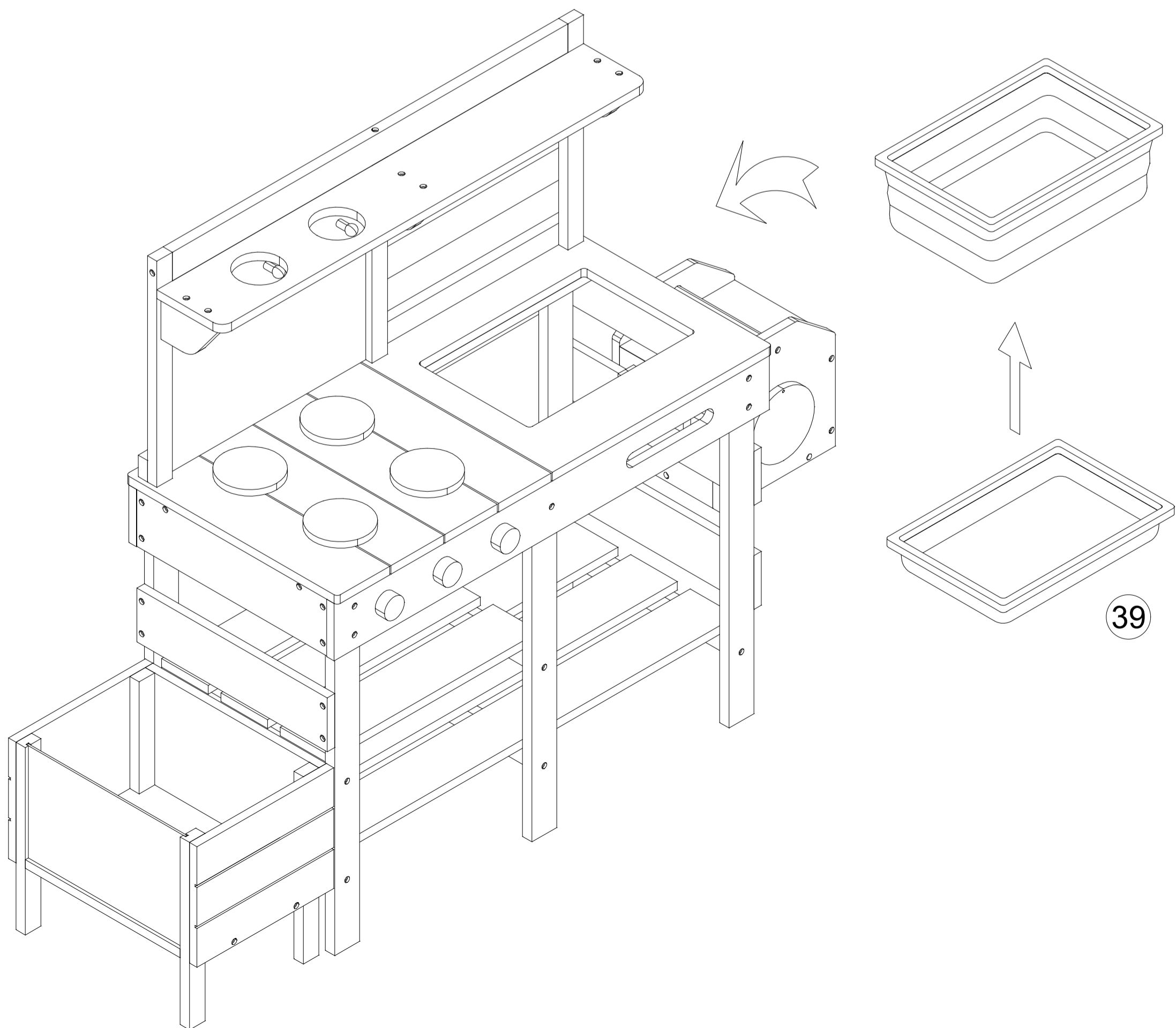
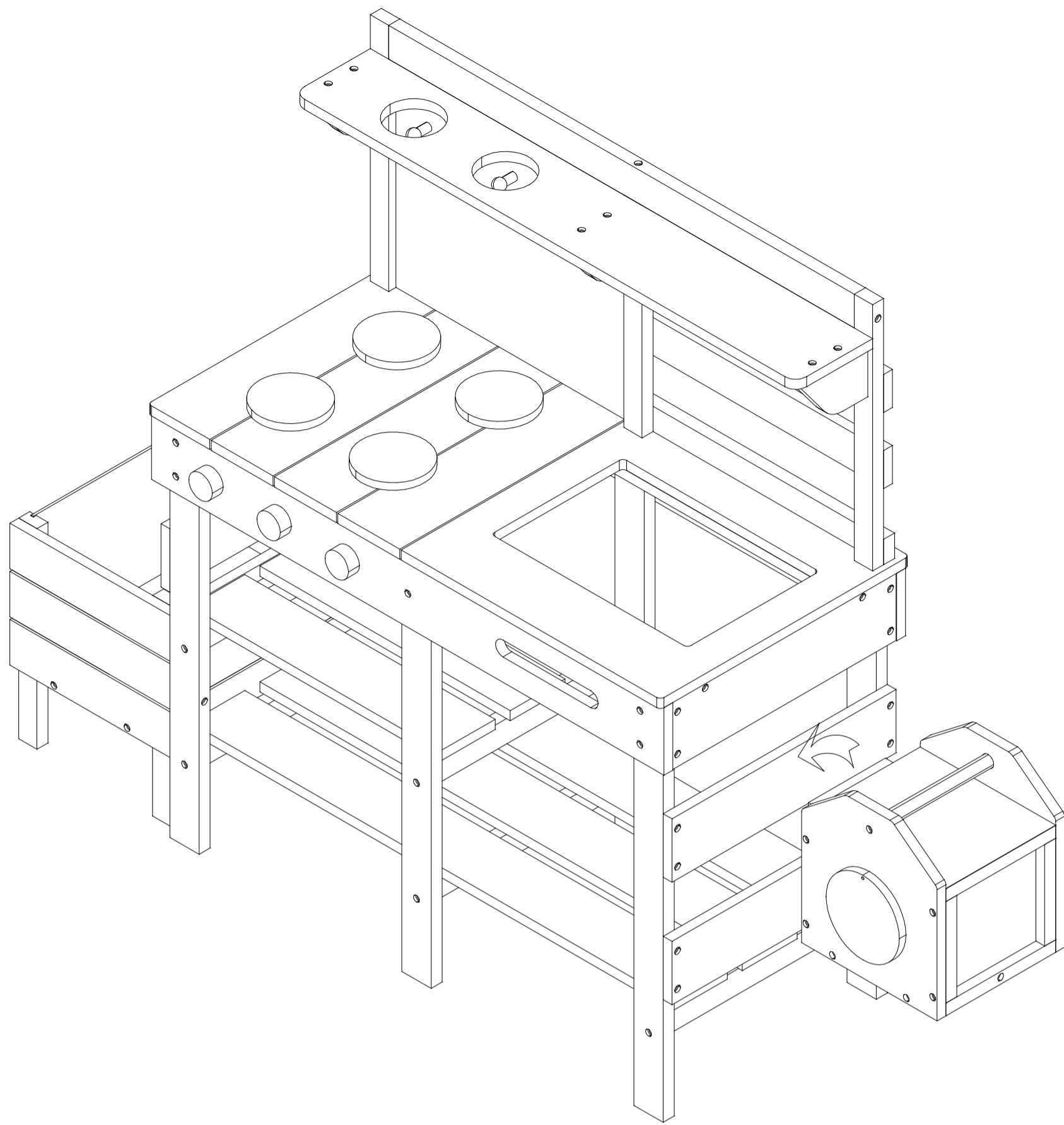

27

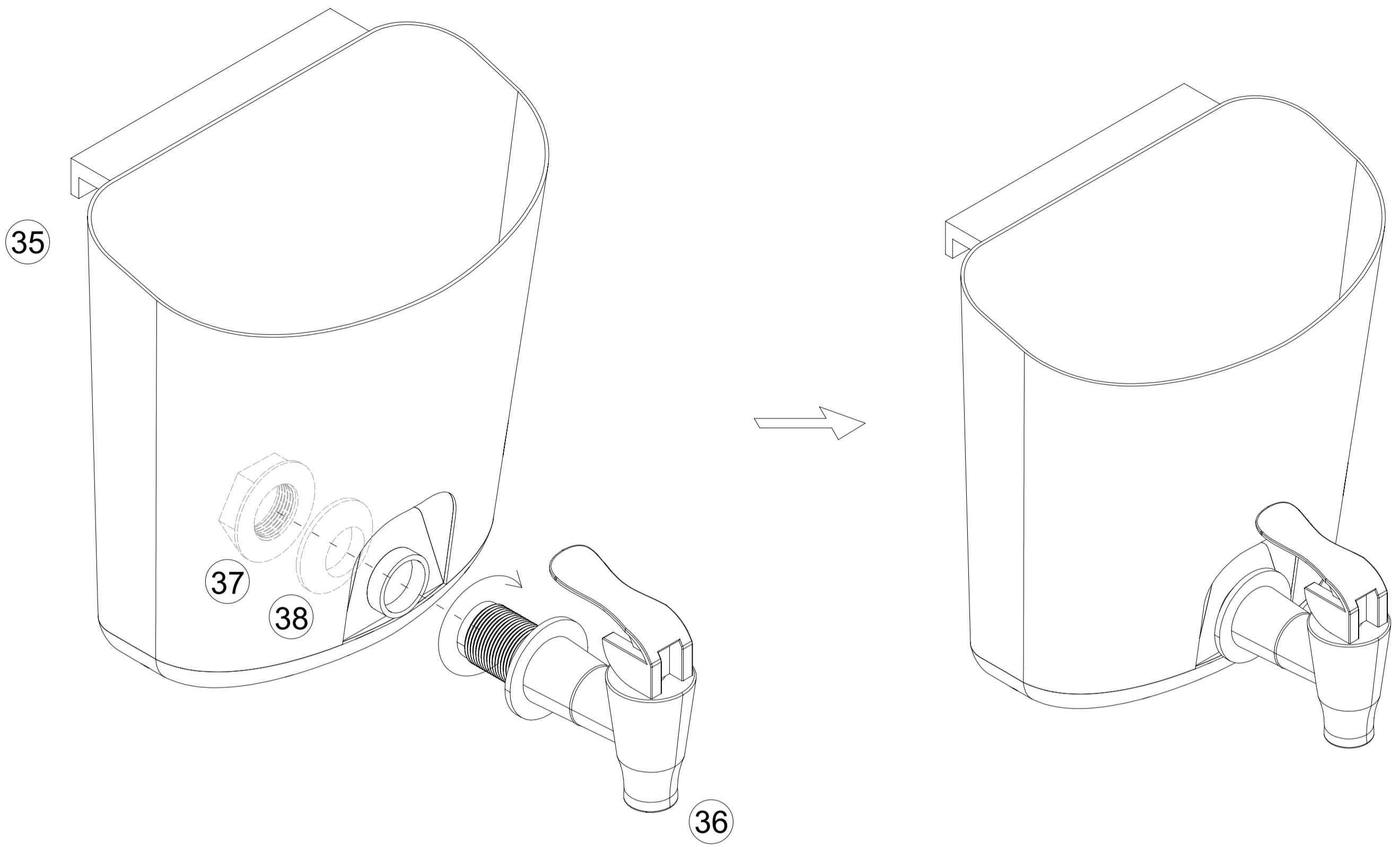

28

