

ASSEMBLY INSTRUCTIONS

LEFT PIER

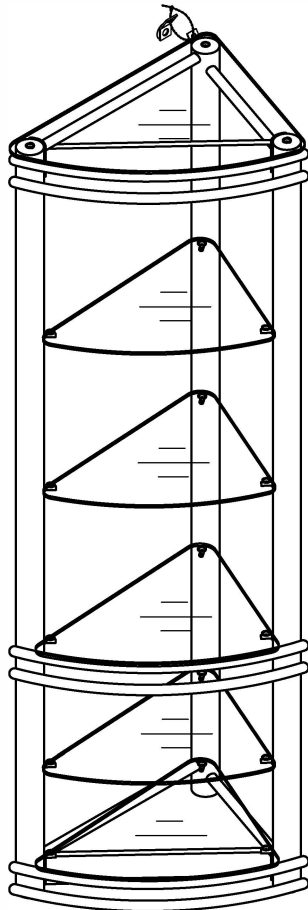

CAUTIONS:
DO NOT FULLY TIGHTEN
SCREWS UNTIL FULLY ASSEMBLED

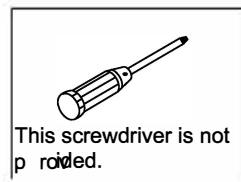

PARTS IDENTIFICATION

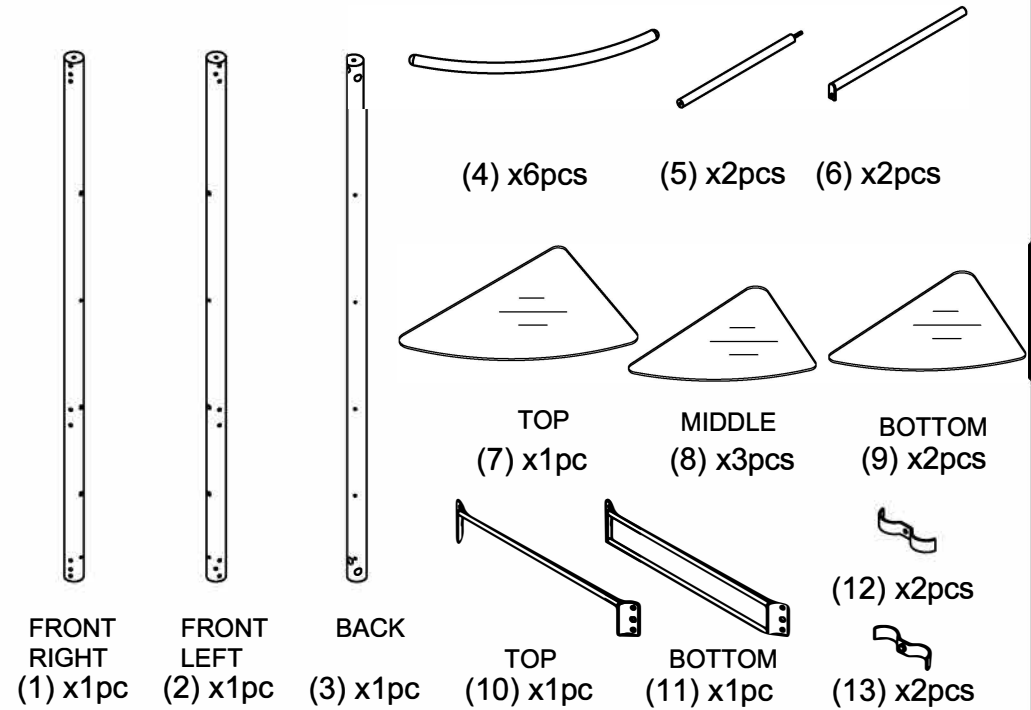



HARDWARE LIST

A		1/4"x2 1/2"	12pcs	G		2pcs
B		1/4"x7/8"	6pcs	H		1pc
C		1/4"x5/8"	2pcs	J		1pc
D			3pcs	K		M4x37mm 1pc
E			15pcs	L		4x4mm 1pc
F			15pcs			

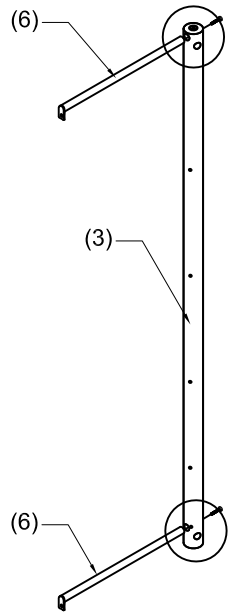
STEP 1:



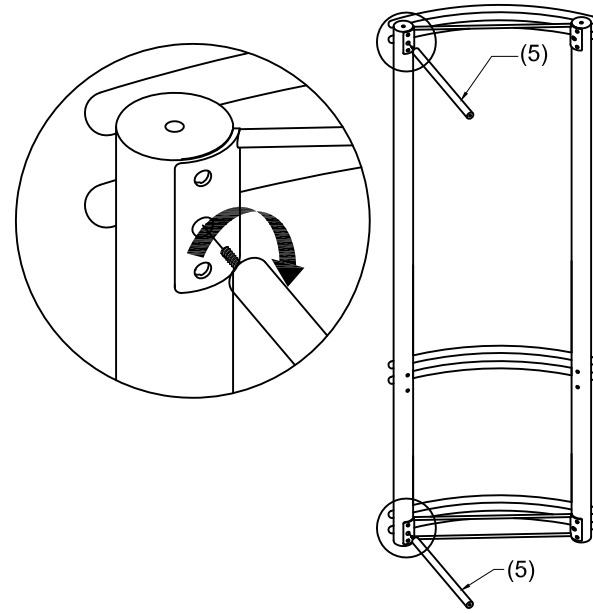

- B  2pcs
- L 

STEP 3:



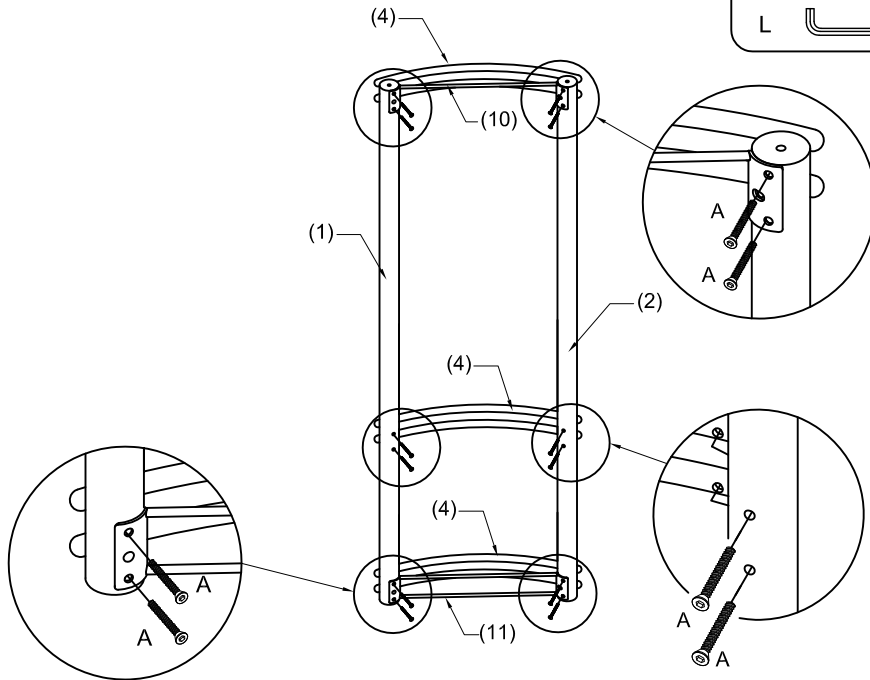



STEP 2:

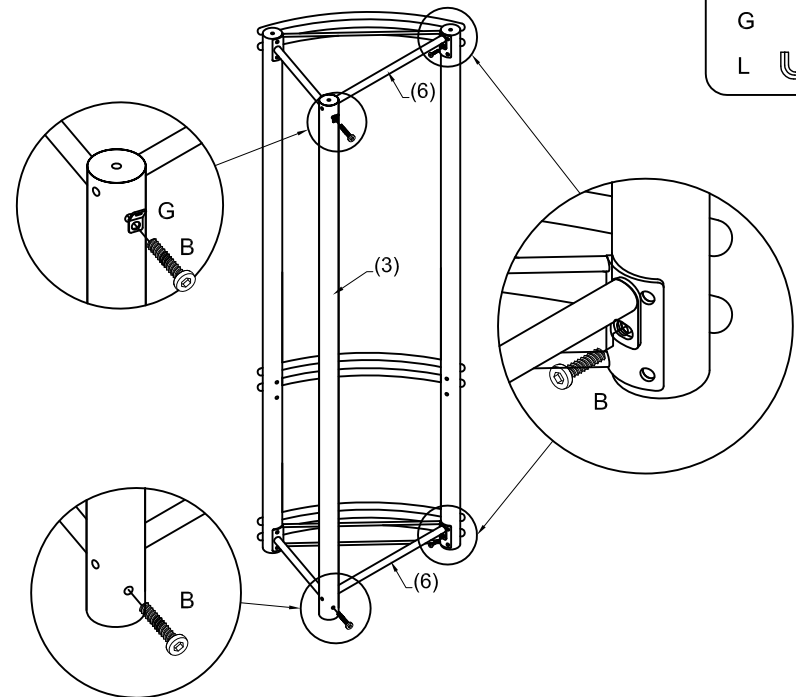

- A  12pcs
- L 



STEP 4:



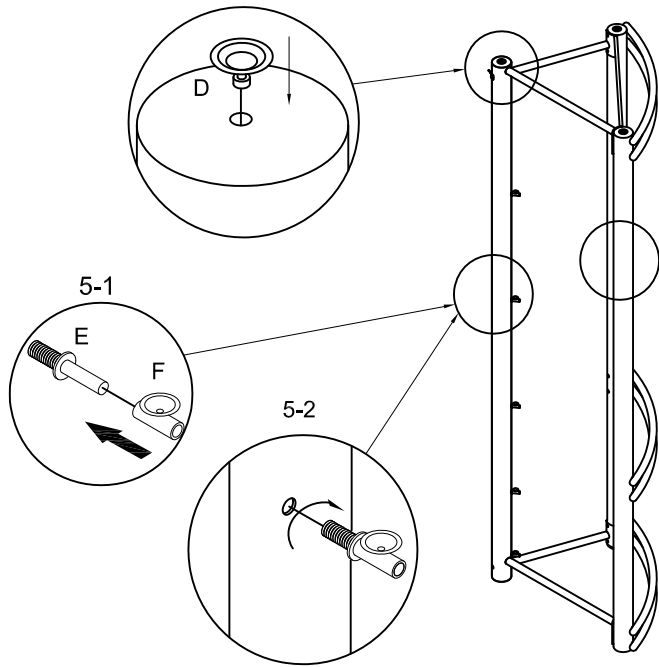

- B  4pcs
- G  1pc
- L 

STEP 5:



- D  3pcs
- E  15pcs
- F  15pcs

STEP 7:

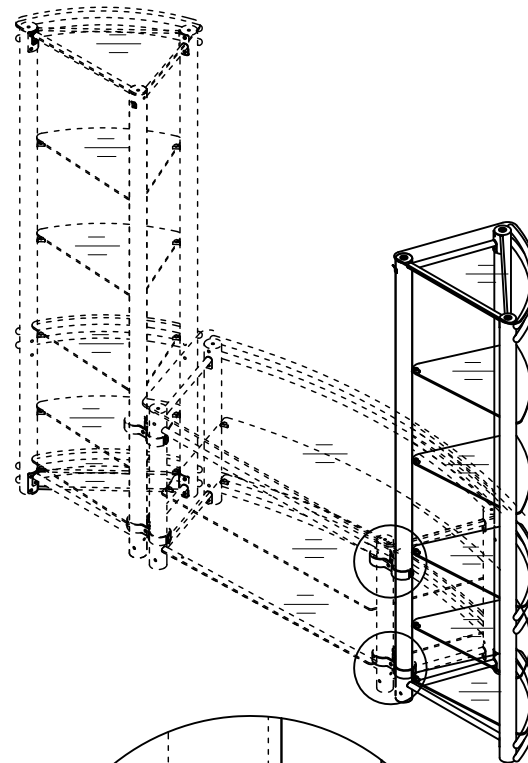

- C  2pcs
- L  2pcs

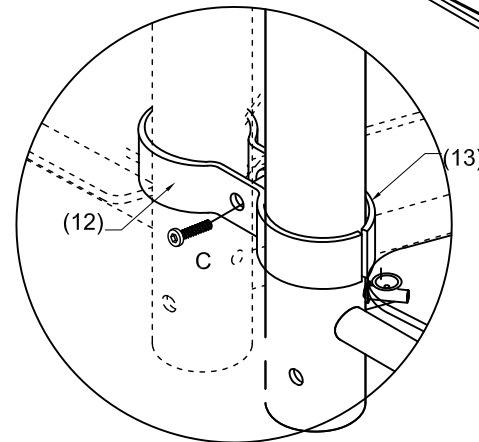
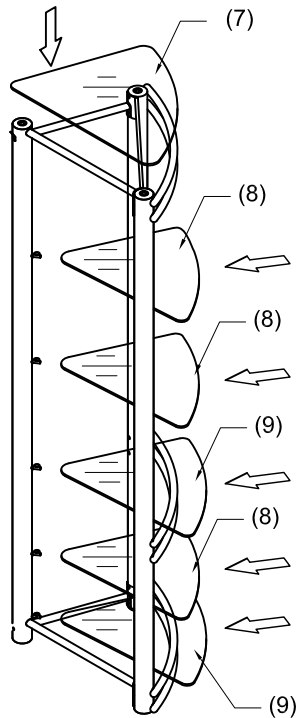

STEP 6:



STEP 9:

G		1PC
H		1PC
K		1PC

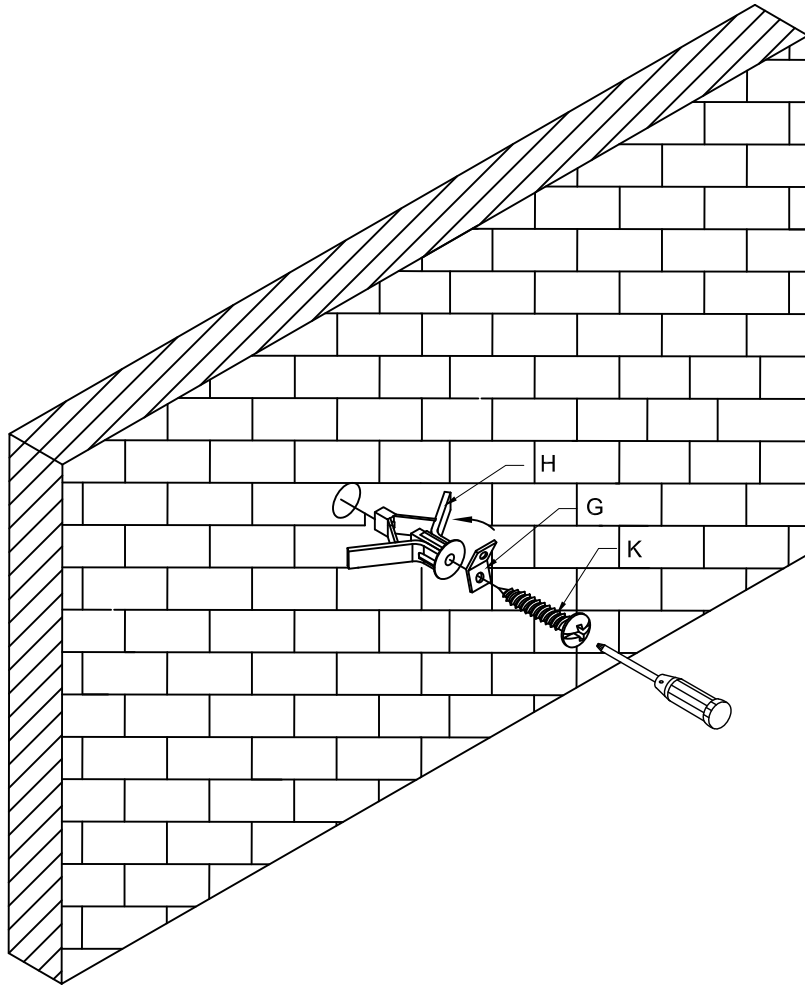

STEP 10:

TO PREVENT TIP OVER
PRODUCT MUST BE
ATTACHED TO WALL

J		1pc
---	--	-----

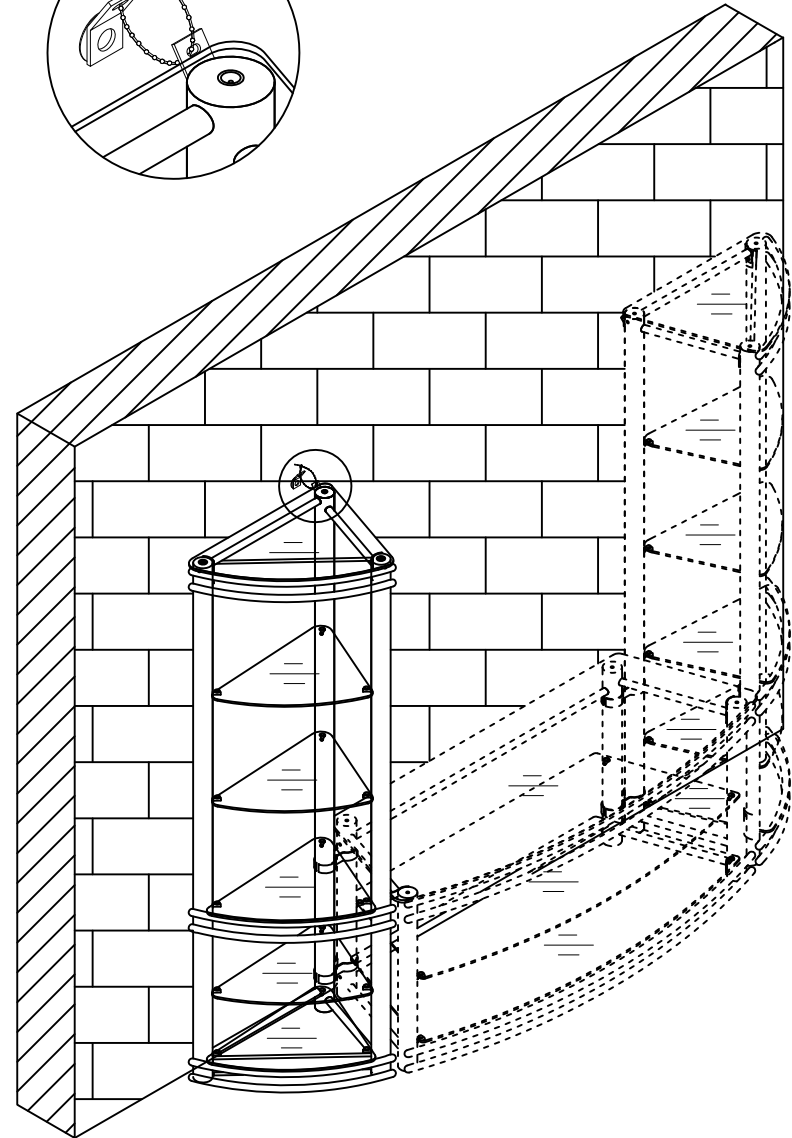
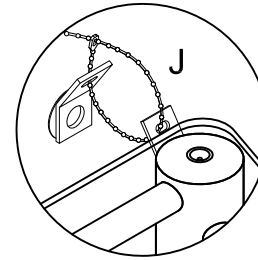

LEFT PIER

ASSEMBLY INSTRUCTIONS

RIGHT PIER

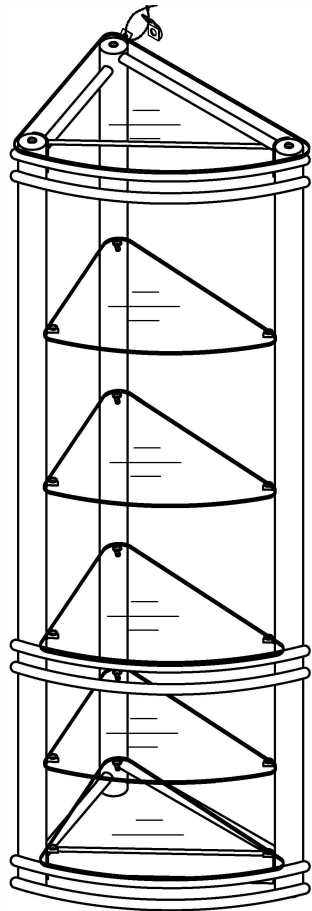

CAUTIONS:
DO NOT FULLY TIGHTEN
SCREWS UNTIL FULLY ASSEMBLED

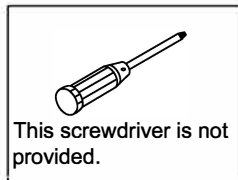

PARTS IDENTIFICATION

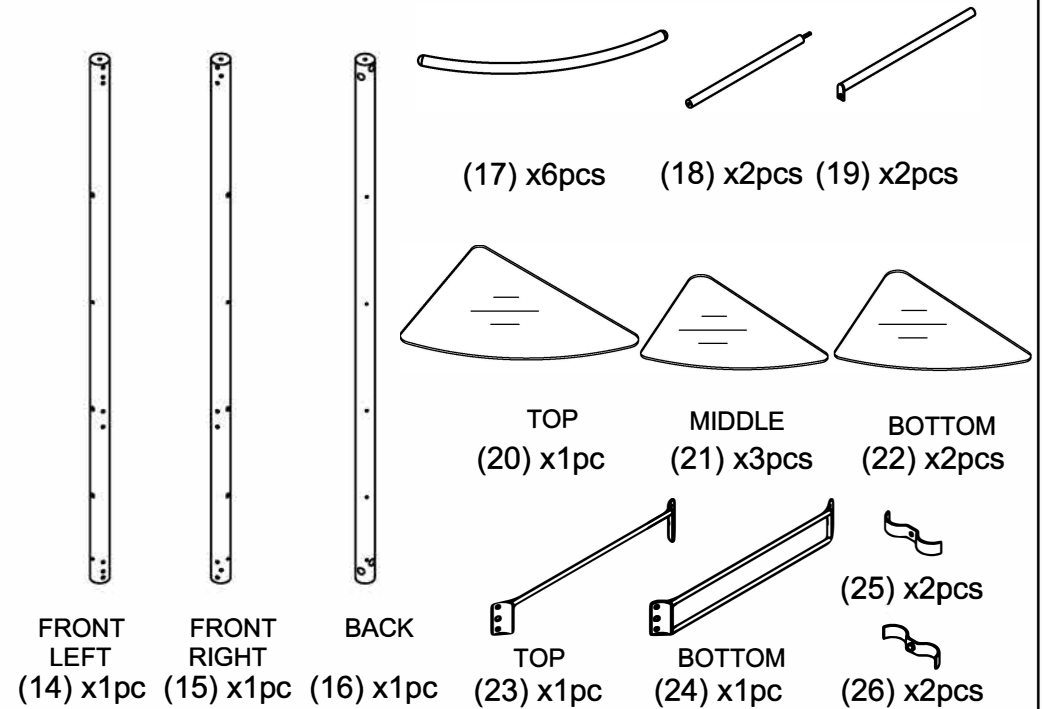



HARDWARE LIST

A		1/4"x2 1/2"	12pcs	G		2pcs
B		1/4"x7/8"	6pcs	H		1pc
C		1/4"x5/8"	2pcs	J		1pc
D			3pcs	K		M4x37mm 1pc
E			15pcs	L		4x4mm 1pc
F			15pcs			

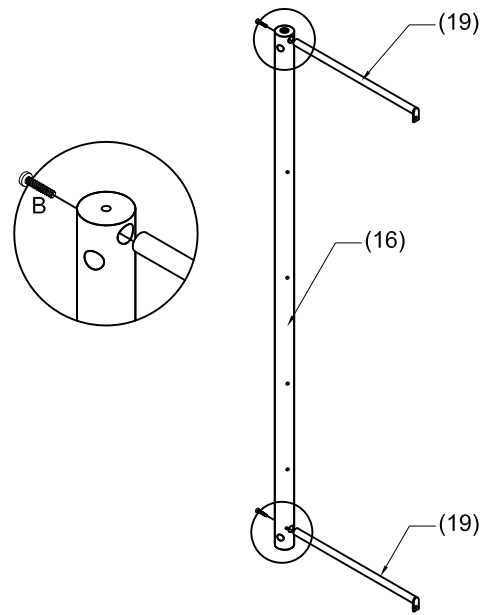
STEP 1:



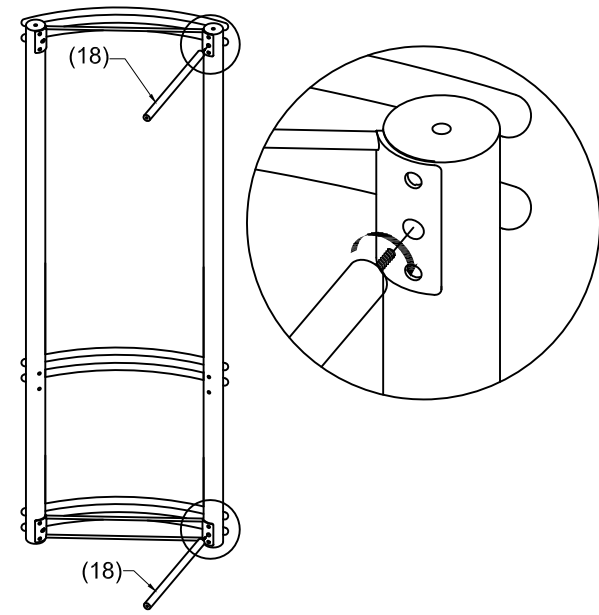

- B  2pcs
- L 

STEP 3:



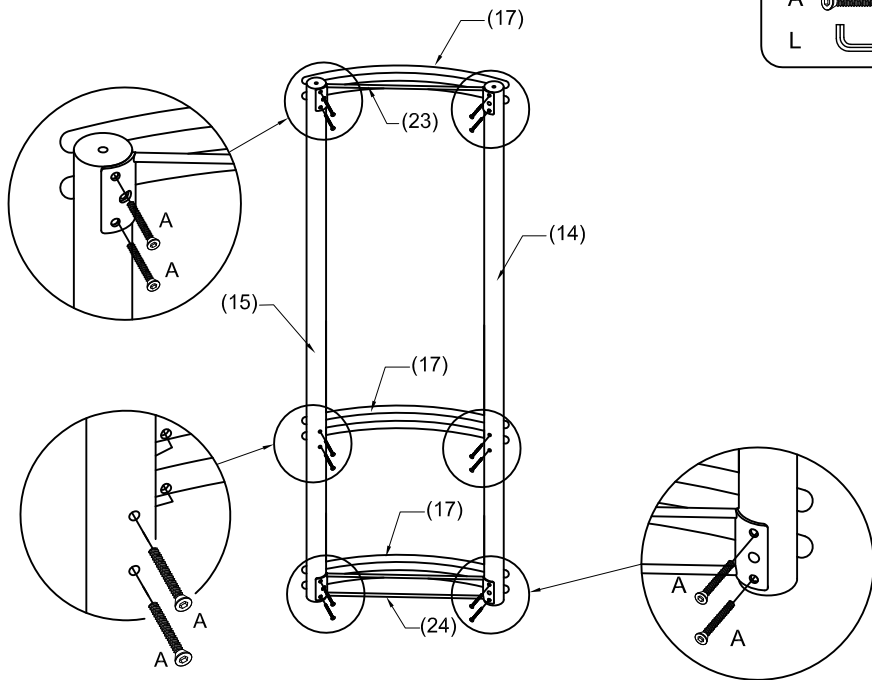



STEP 2:

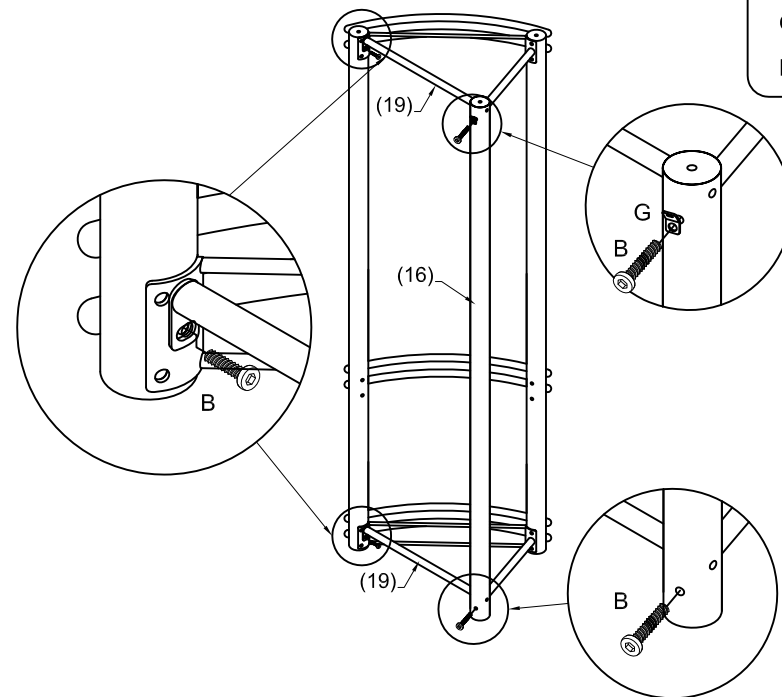

- A  12pcs
- L 

STEP 4:



- B  4pcs
- G  1pc
- L 

STEP 5:

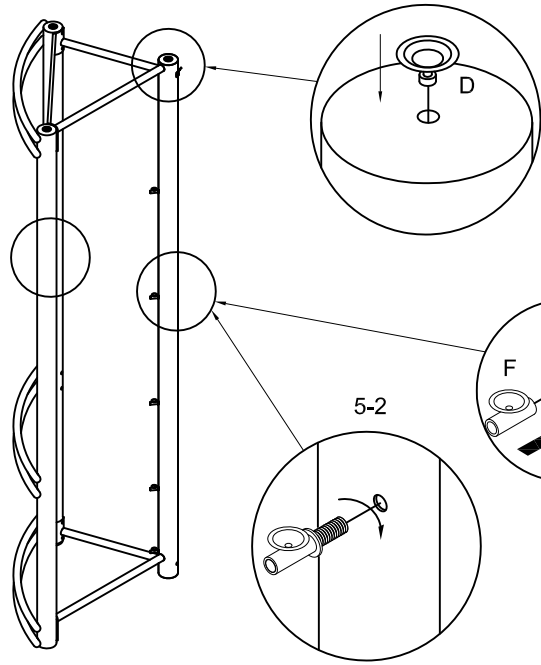

- | | | |
|---|--|-------|
| D | | 3pcs |
| E | | 15pcs |
| F | | 15pcs |

STEP 7:

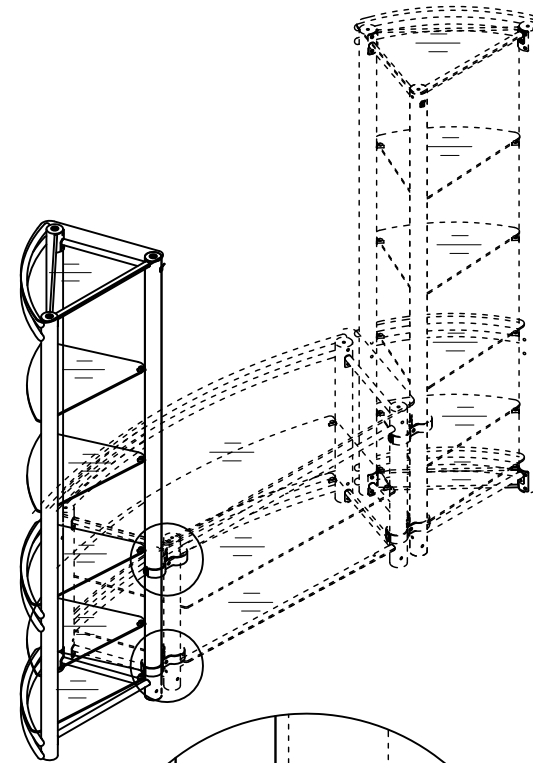

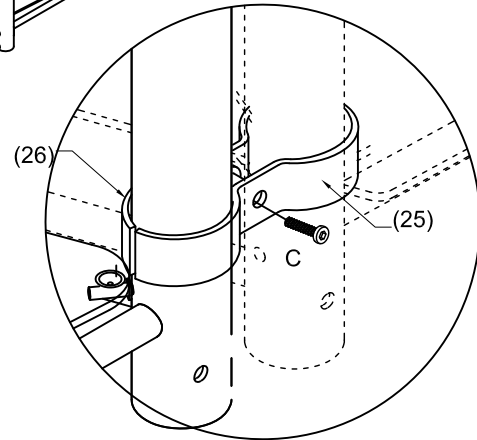
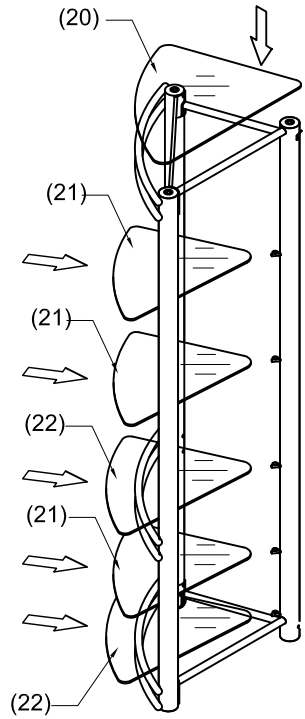

- | | | |
|---|--|------|
| C | | 2pcs |
| L | | |

STEP 6:



STEP 9:

G		1PC
H		1PC
K		1PC

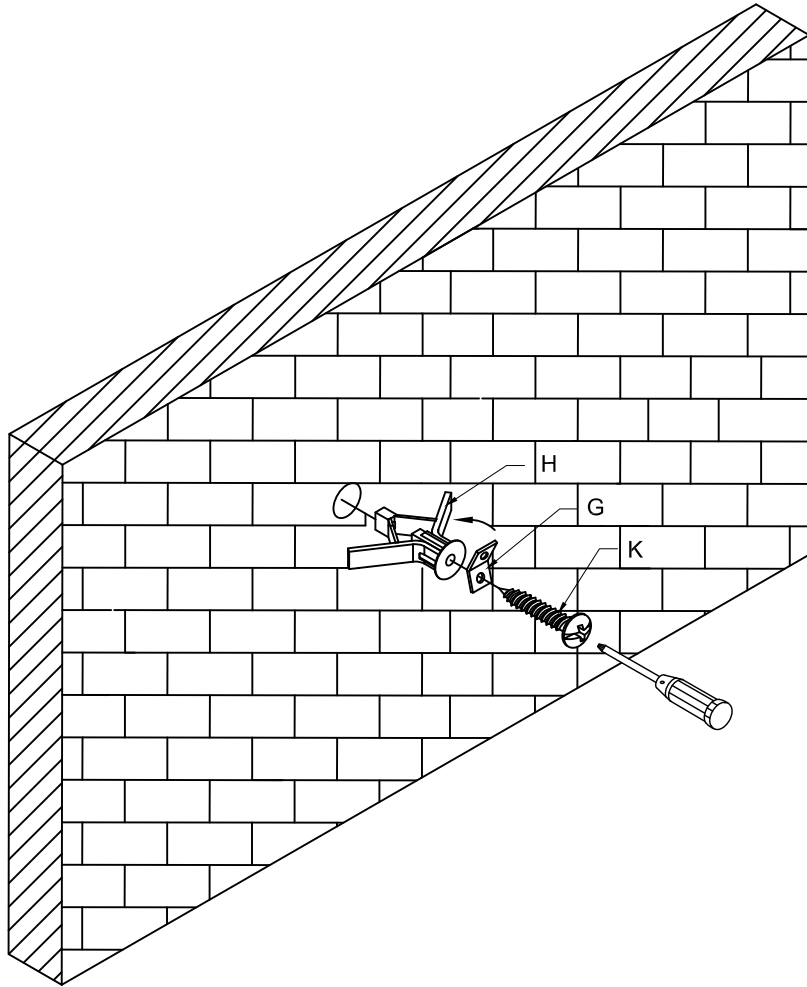

STEP 10:

TO PREVENT TIP OVER
PRODUCT MUST BE
ATTACHED TO WALL

J		1pc
---	--	-----

