

Assembly | Asambla | Assemblage

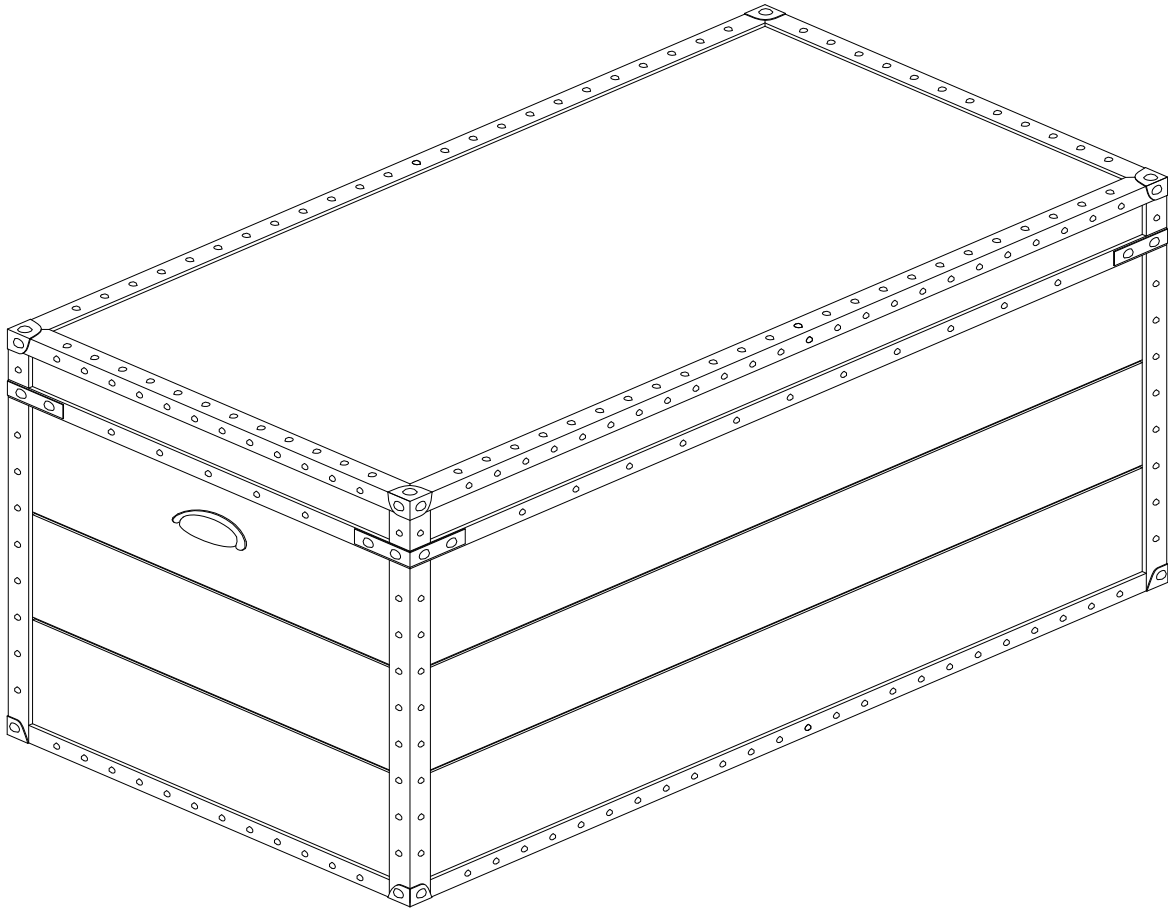

Assembly | Asamblea | Assemblage

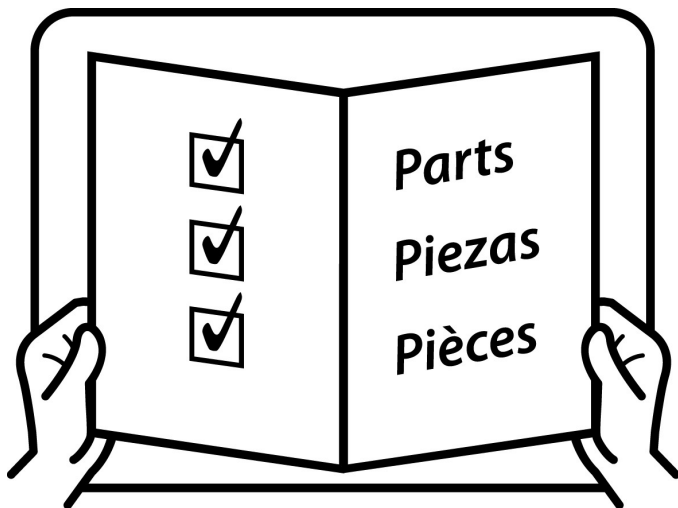
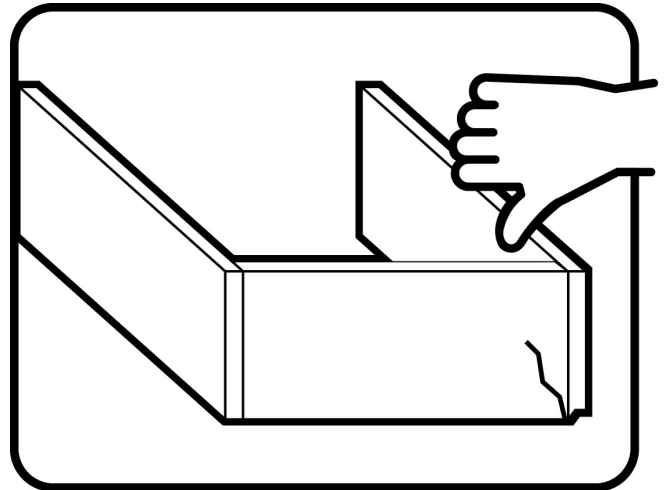
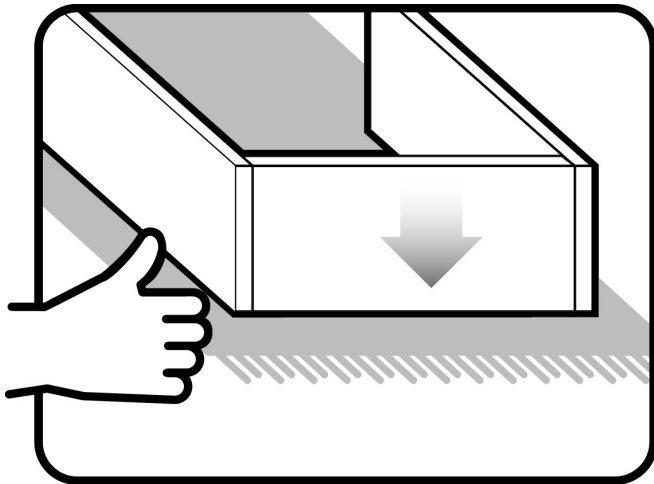
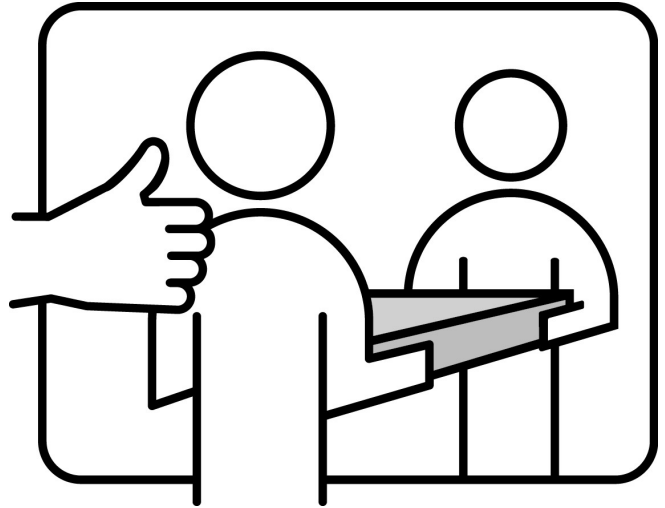
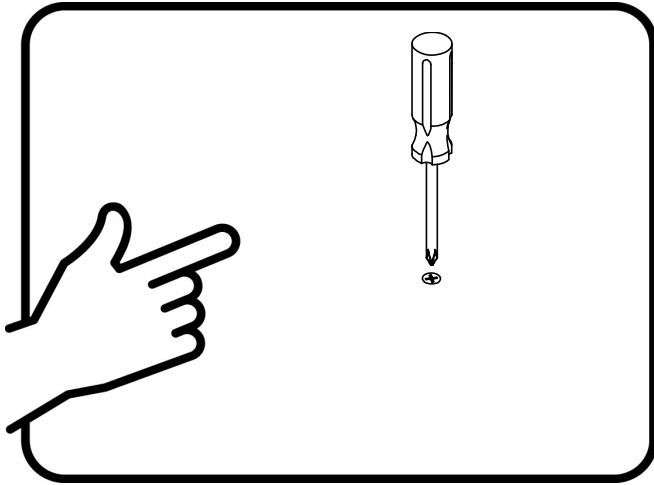

Assembly | Asamblea | Assemblage

Techniques | Técnicas | Techniques

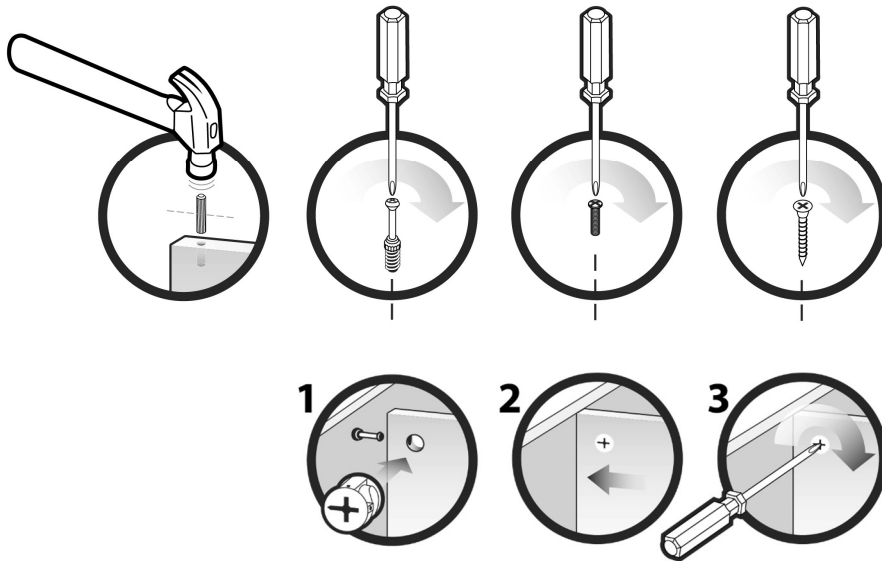

Care | Cuidado | Entretien



Safety | Seguridad | Sécurité





Note! | ¡Nota! | Remarque!

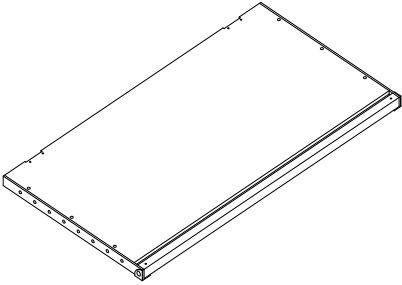
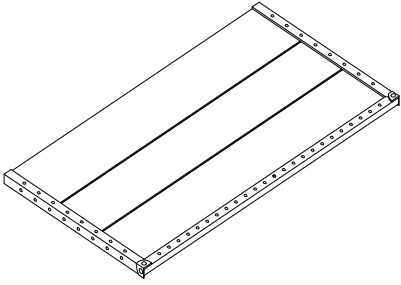
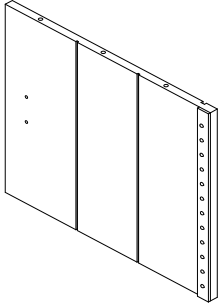
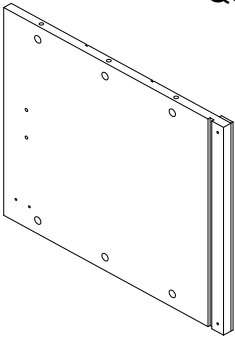
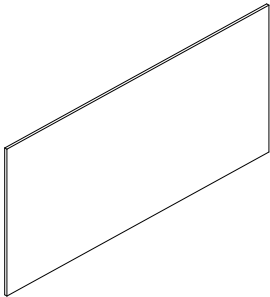
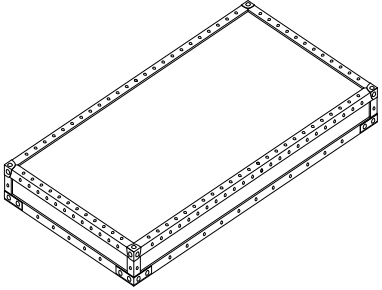

Assembly | Asamblea | Assemblage

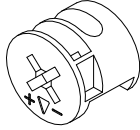
<p>A</p> <p>Quantity of 1</p>  <p>Back Panel</p>	<p>B</p> <p>Quantity of 1</p>  <p>Front Panel</p>	<p>C</p> <p>Quantity of 1</p>  <p>Left side panel</p>
<p>D</p> <p>Quantity of 1</p>  <p>Right side panel</p>	<p>E</p> <p>Quantity of 1</p>  <p>Bottom panel</p>	<p>F</p> <p>Quantity of 1</p>  <p>Top panel</p>

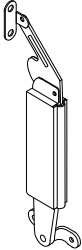
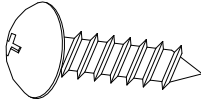
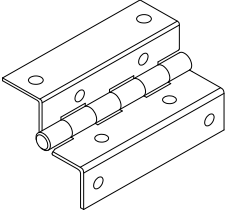
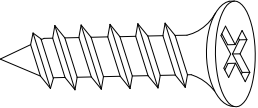
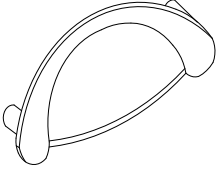
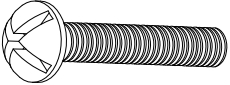
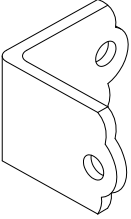

Assembly | Asambla | Assemblage

<p>1. Quantity of 12</p>  <p>Cam Bolt</p>	<p>2. Quantity of 12</p>  <p>Cam lock</p>	<p>3. Quantity of 1</p>  <p>Left-safe support</p>
<p>4. Quantity of 1</p>  <p>Right-safe support</p>	<p>5. Quantity of 8</p>  <p>Screw $\text{\O}3 \times 12$</p>	<p>6. Quantity of 2</p>  <p>Hinge</p>
<p>7. Quantity of 24</p>  <p>Screw $\text{\O}3 \times 15$</p>	<p>8. Quantity of 2</p>  <p>Handle</p>	<p>9. Quantity of 4</p>  <p>Bolt $\text{\O}5/32" \times 1"$</p>
<p>10. Quantity Of 4</p>  <p>Conection corner iron</p>	<p>11. Quantity of 14</p>  <p>Cover</p>	

Assembly | Asambla | Assemblage

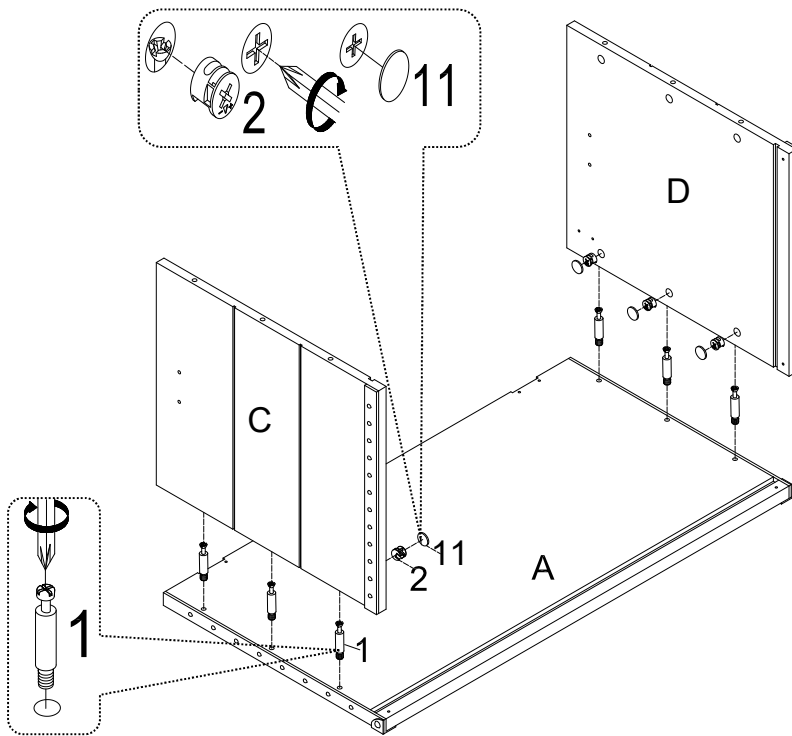
1

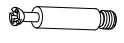

1		X6
2		X6
11		X6

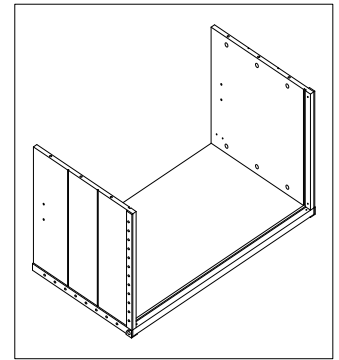

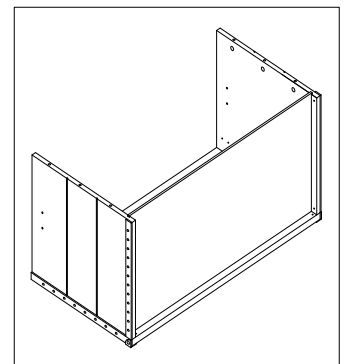
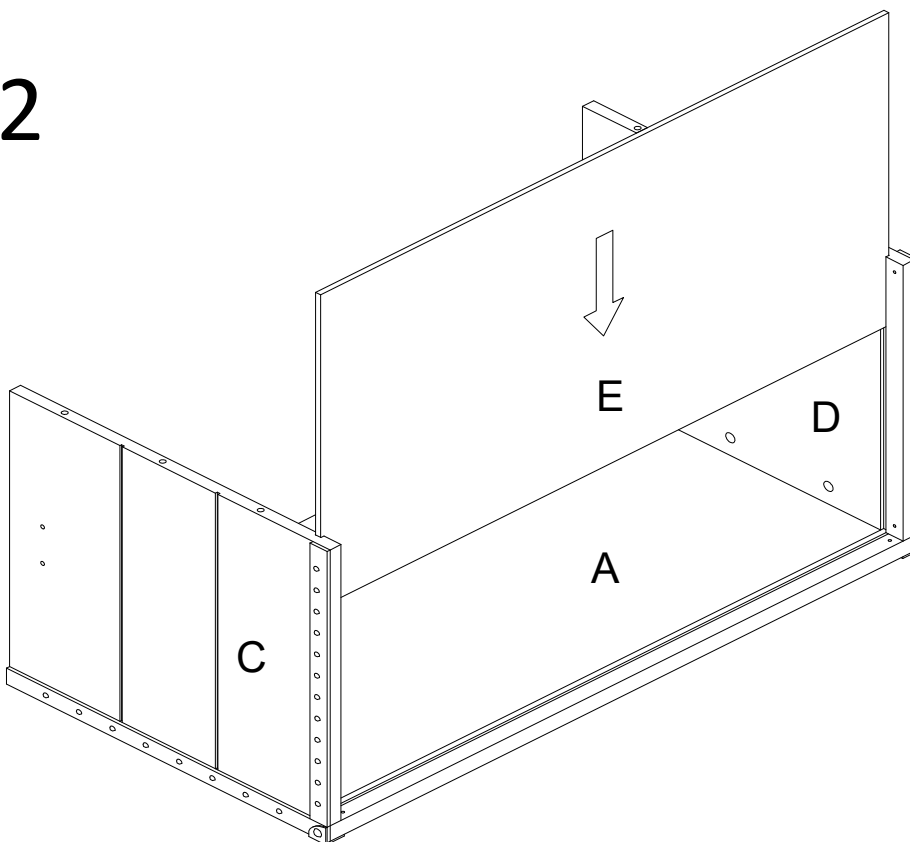

2

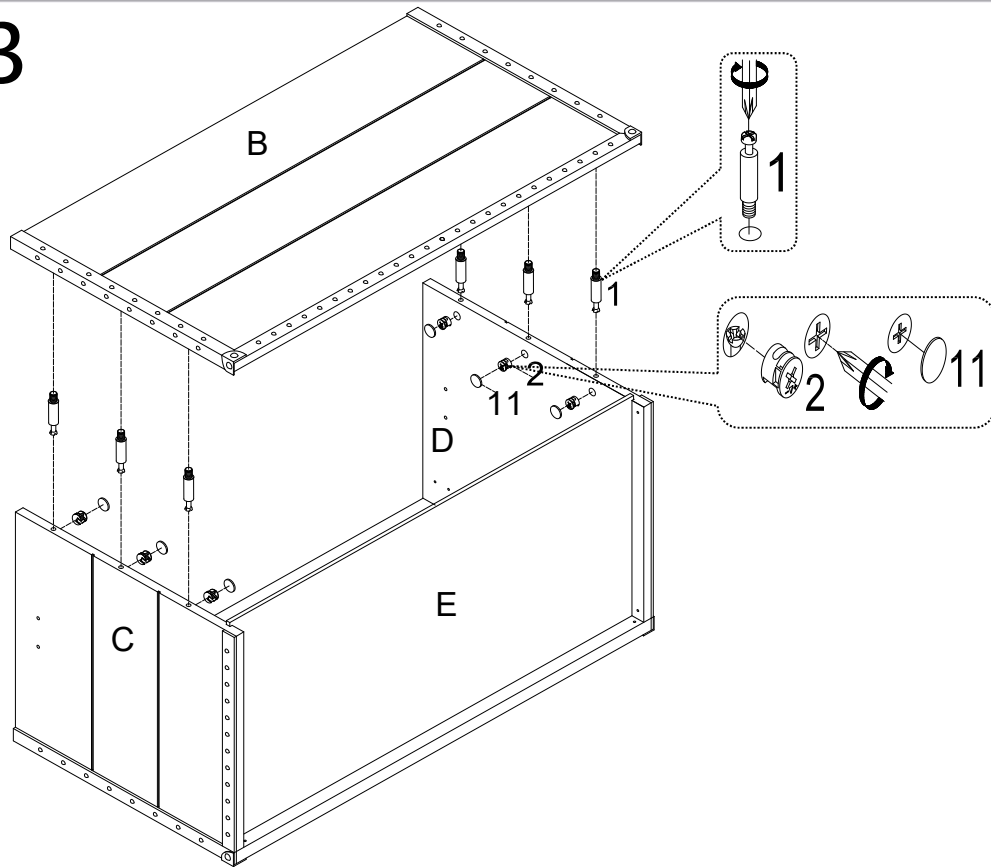

Assembly | Asambla | Assemblage

3

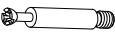

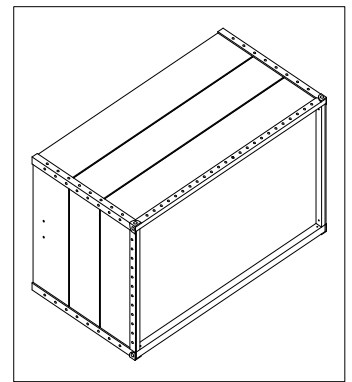

1		X6
2		X6
11		X6

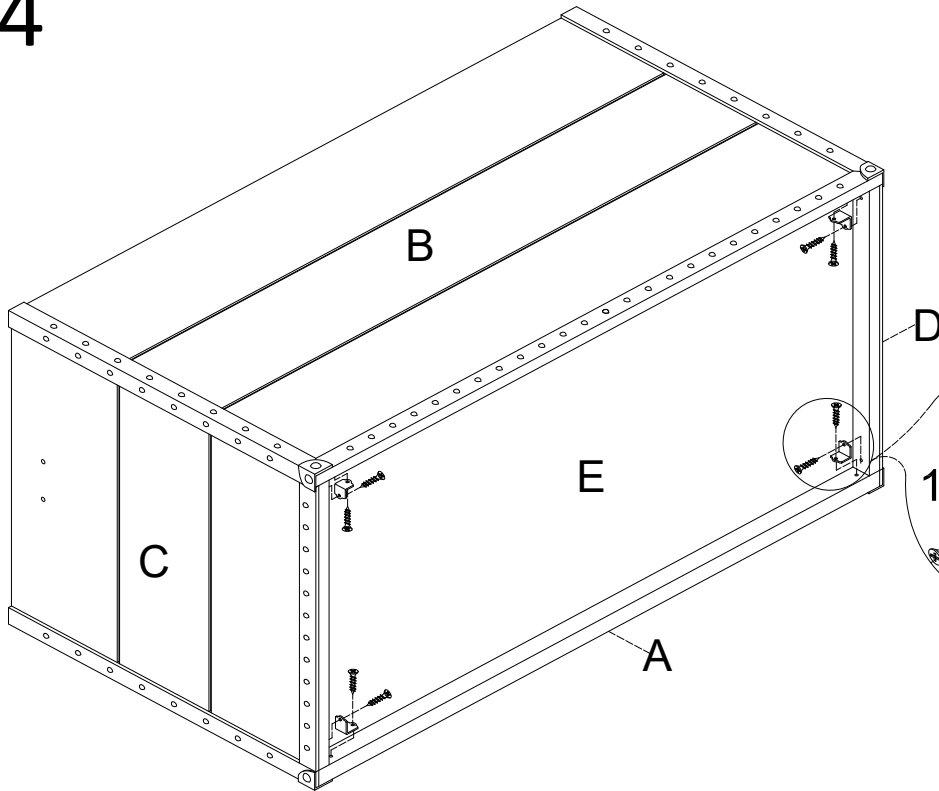

Assembly | Asambla | Assemblage

4





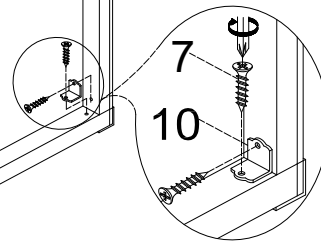

7		X8
10		X4

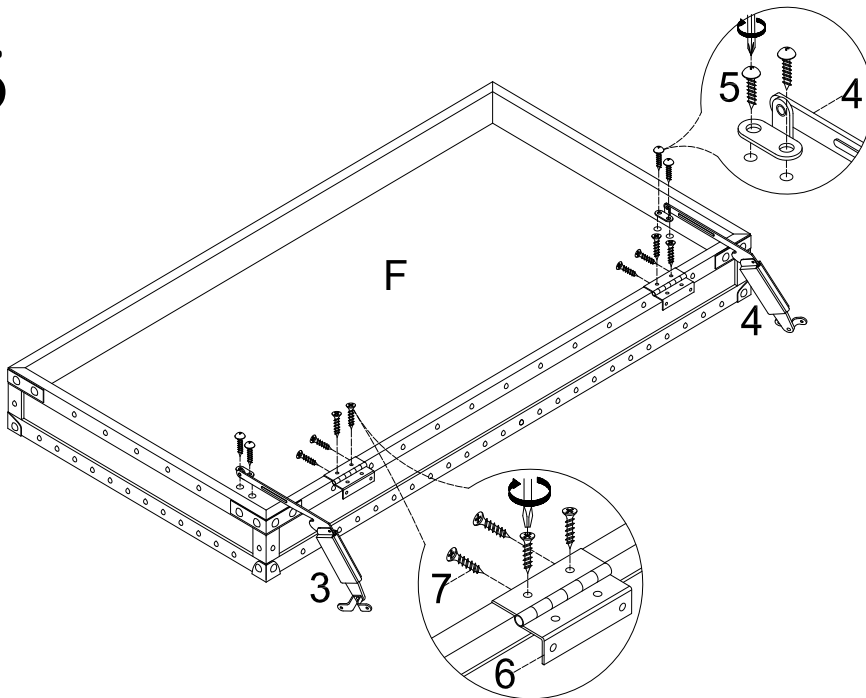

5



3		X1
4		X1
5		X4
6		X2
7		X8

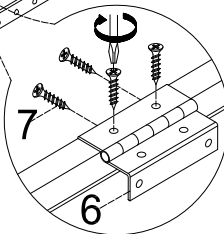
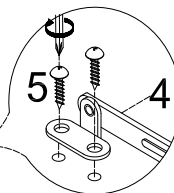

6

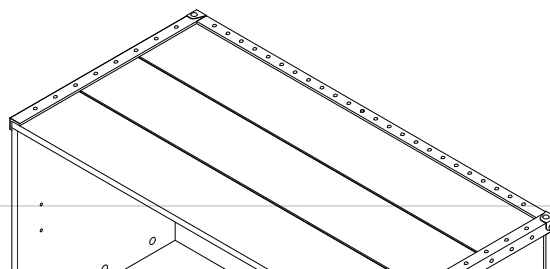

7		X8
---	---	----

Assembly | Asamblea | Assemblage

Lay trunk on a clean, padded surface like carpet or a blanket, then slightly lift the lid to attach the hinges.

Coloque el tronco sobre una superficie limpia y acolchada, como una alfombra o una manta, luego levante ligeramente la tapa para sujetar las bisagras.

Posez le coffre sur une surface propre et rembourrée comme un tapis ou une couverture, puis soulevez légèrement le couvercle pour attacher les charnières.

7

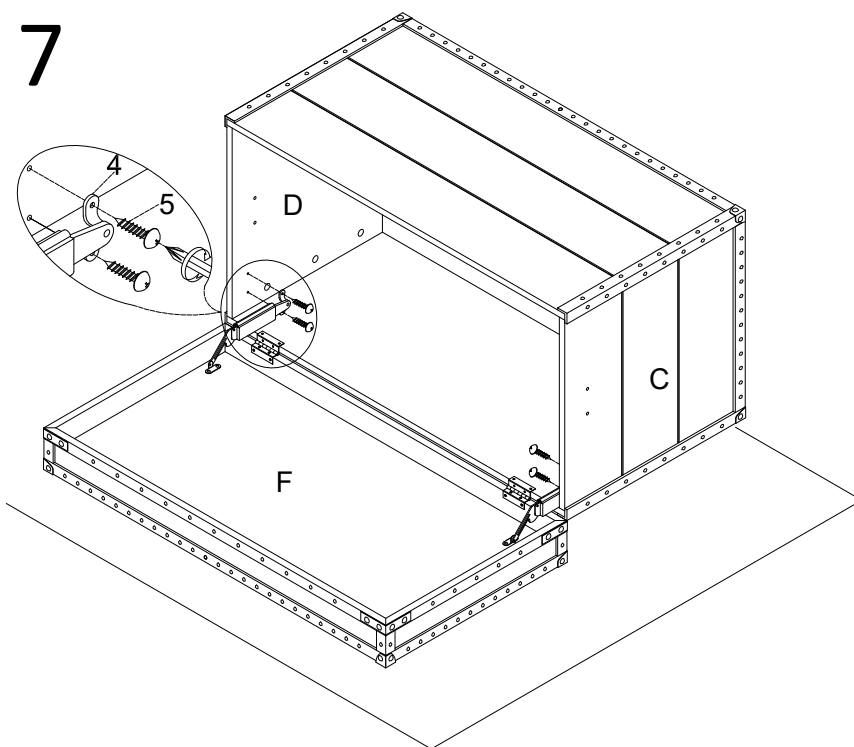

5



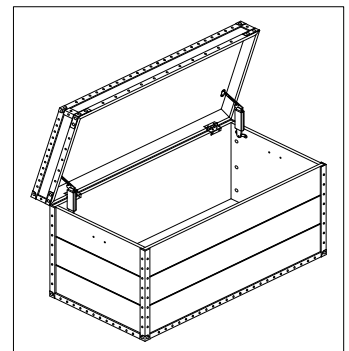

X4

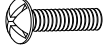

Assembly | Asambla | Assemblage

8

8		X2
9		X4
11		X2

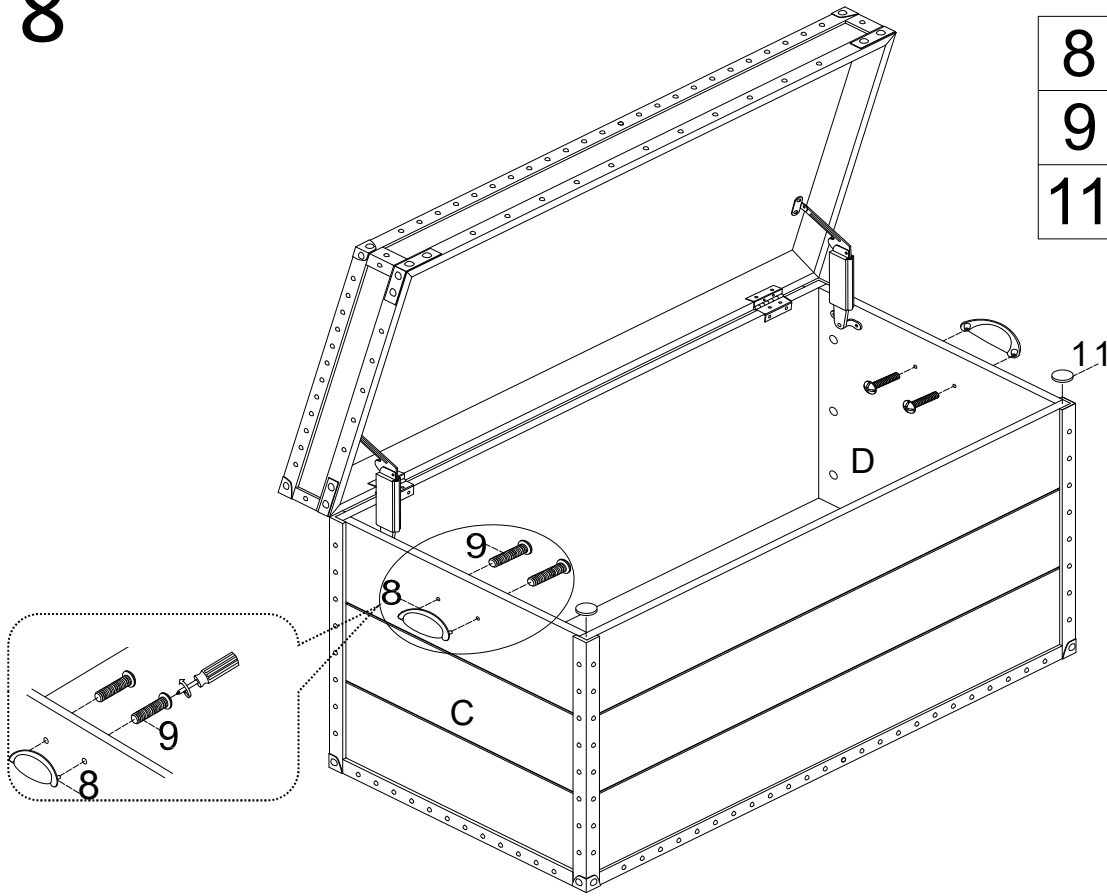

Assembly | Asambla | Assemblage

9

