

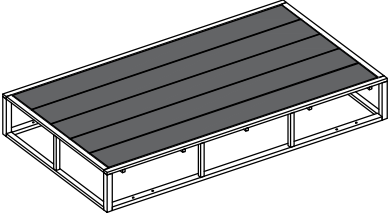

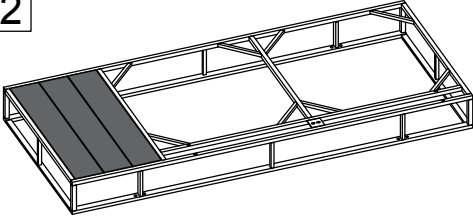
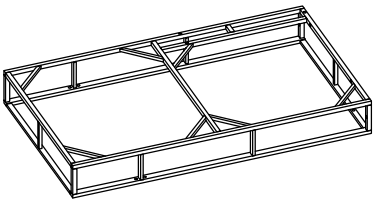
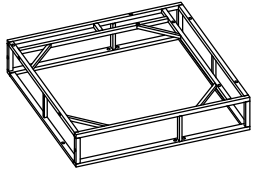
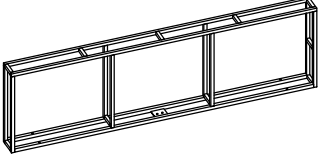
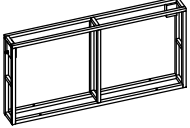
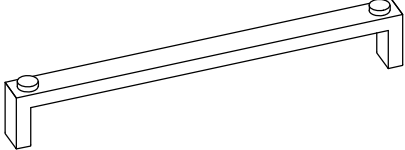
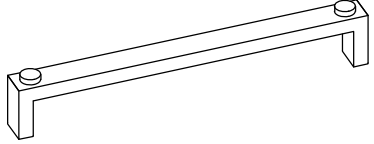
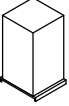
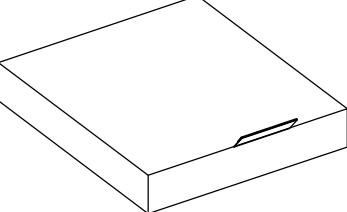
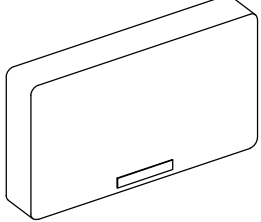
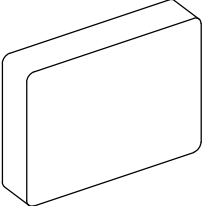
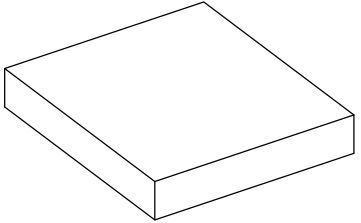
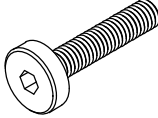
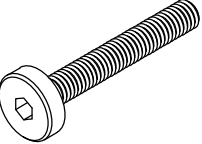
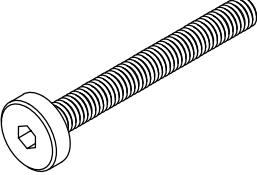

Notice:

1. 50% Tighten before fixing all screws, Allen wrench is recommended instead of an electric drill.
2. Place the item on a flat ground to adjust and make sure it remains stable.
3. Tighten up all screws with tools gradually.
4. If the screws are not aligned with holes during assembly, please loosen all the other screws to 50% and continue the assembly process.
5. If the item is not stable, please loosen all the screws, adjust it on a flat ground and tighten up all screws again.
6. Note : If one or some screws are fully tightened during assembly, chances are the others will not be aligned with holes. In addition, all the holes are designed to be relatively larger to provide more space for the adjustment of the screws.

# Part List and Hardware:

<p>1</p>  <p>Table Frame (1pc)</p>	<p>2</p>  <p>Left Bench Frame (1pc)</p>	<p>3</p>  <p>Right Bench Frame (1pc)</p>	<p>4</p>  <p>Corner Bench Frame (1pc)</p>	
<p>5</p>  <p>Back Bench Frame (2pcs)</p>	<p>6</p>  <p>Back Corner Frame (1pc)</p>	<p>7</p>  <p>Leg Sofa Frame (4pcs)</p>	<p>9</p>  <p>Leg Table Frame (2pcs)</p>	
<p>11</p>  <p>Leg Middle Bench Frame (1pc)</p>	<p>H</p>  <p>Seat Bench Cushion (4pcs)</p>	<p>I</p>  <p>Back Bench Cushion (4pcs)</p>	<p>J</p>  <p>Back Corner Cushion (1pc)</p>	
<p>K</p>  <p>Seat Stool Cushion (1pc)</p>	<p>A</p>  <p>M6 x 25mm : 28pcs</p>	<p>B</p>  <p>M6 x 40mm : 14pcs</p>	<p>C</p>  <p>M6 x 50mm : 4pcs</p>	
<p>D</p>  <p>Nut M6 4pcs</p>	<p>E</p>  <p>Flat washer M6 50pcs</p>	<p>F</p>  <p>Allen Key : 2pc</p>	<p>G</p>  <p>Key : 1pc</p>	<p>P</p>  <p>Connector : 2pcs</p>

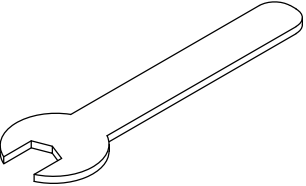
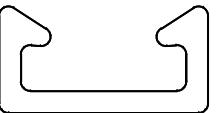
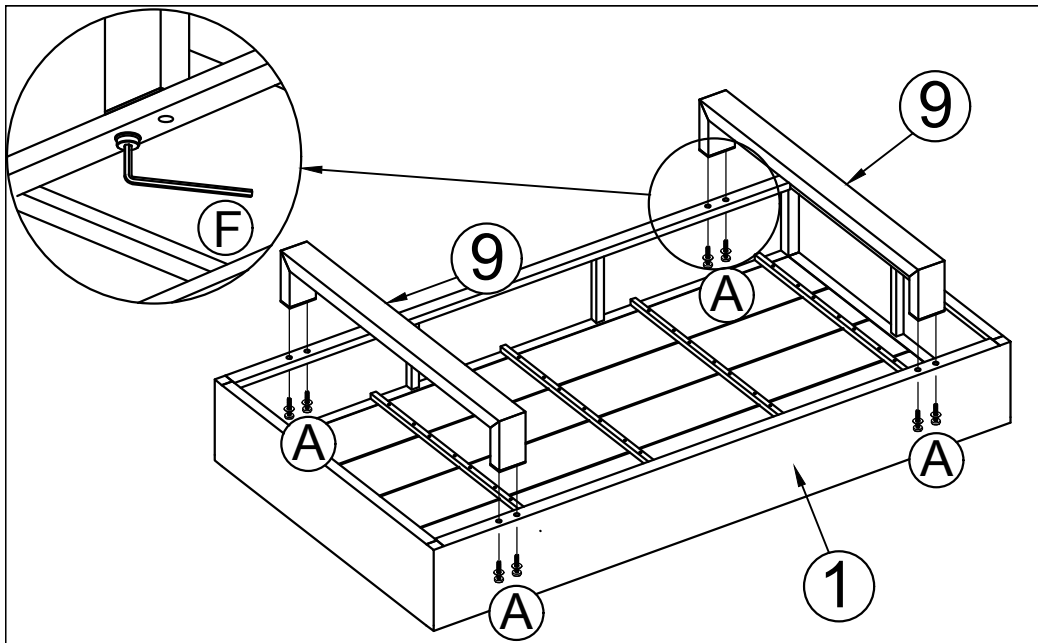

Step 1: Connect Table Frame (1) & Leg Table Frame (9), tighten Bolt (A), Flat Washer (E) with Allen Key (F).

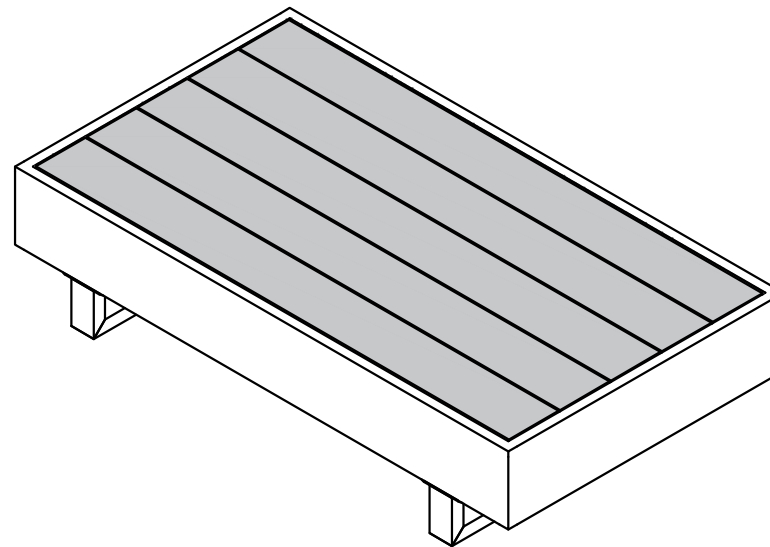

Finish Table

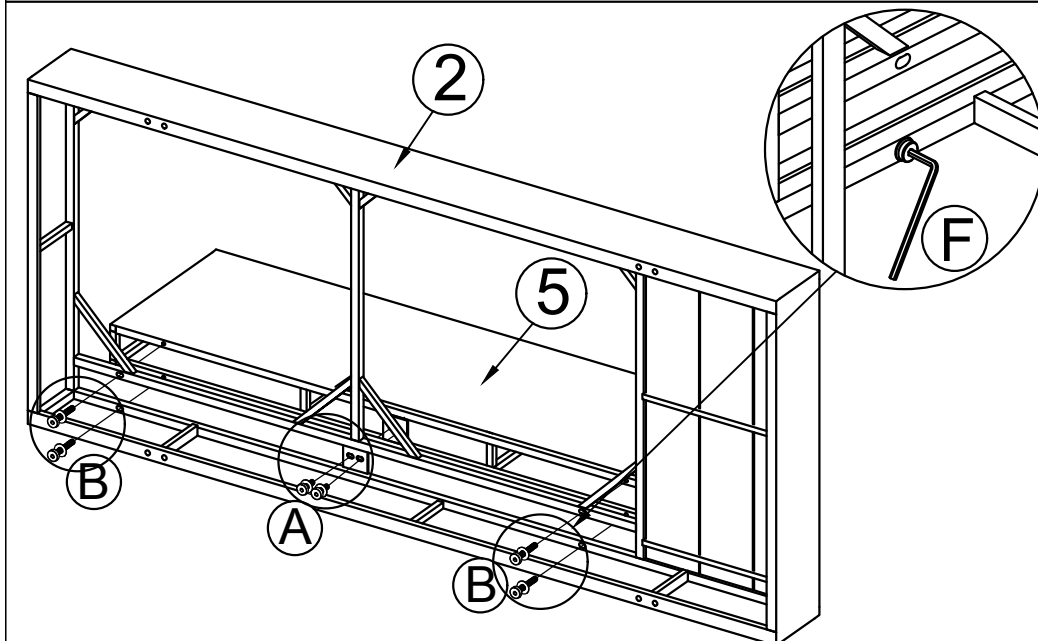

Step 2: Connect Left Bench Frame (2) & Back Bench Frame (5), tighten Bolt (A),(B), Flat Washer (E) with Allen Key (F).

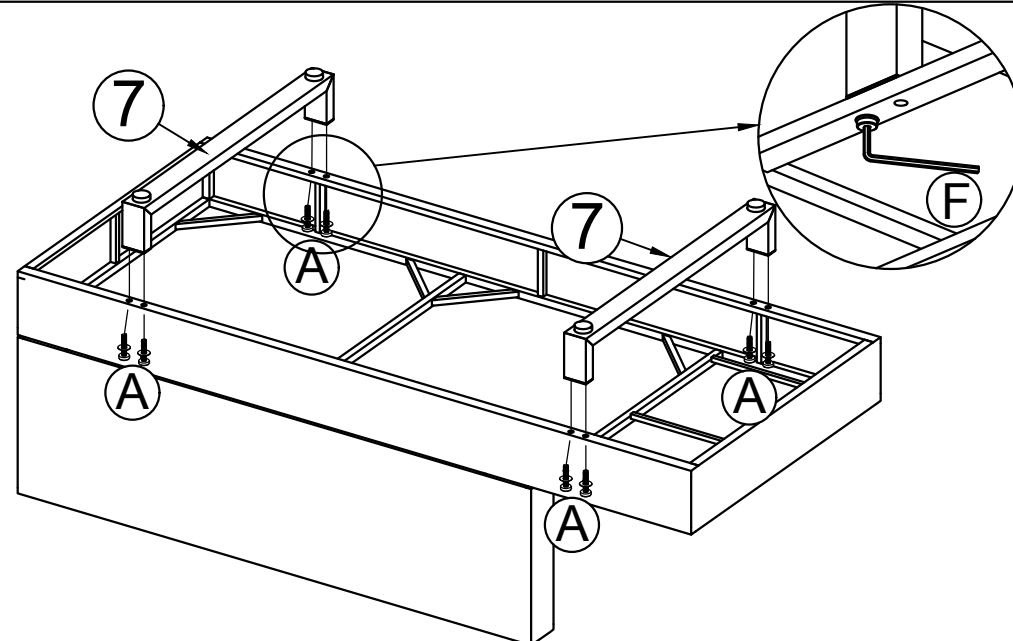

Step 3: Connect The Part from Step 2 & Leg Sofa Frame (7), tighten Bolt (A), Flat Washer (E) with Allen Key (F).

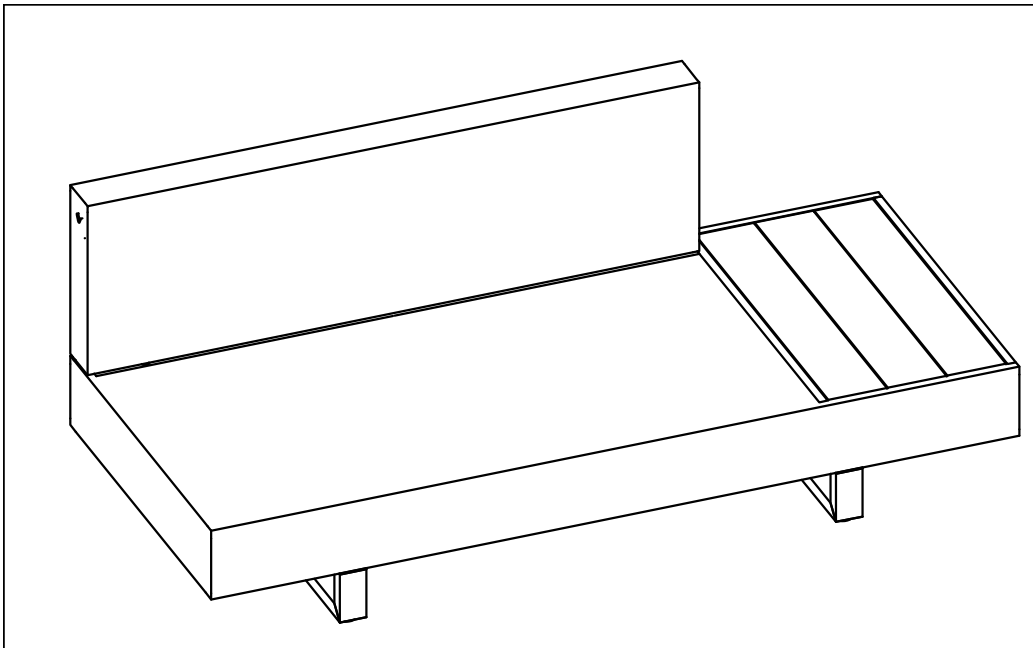

Finish Left Bench

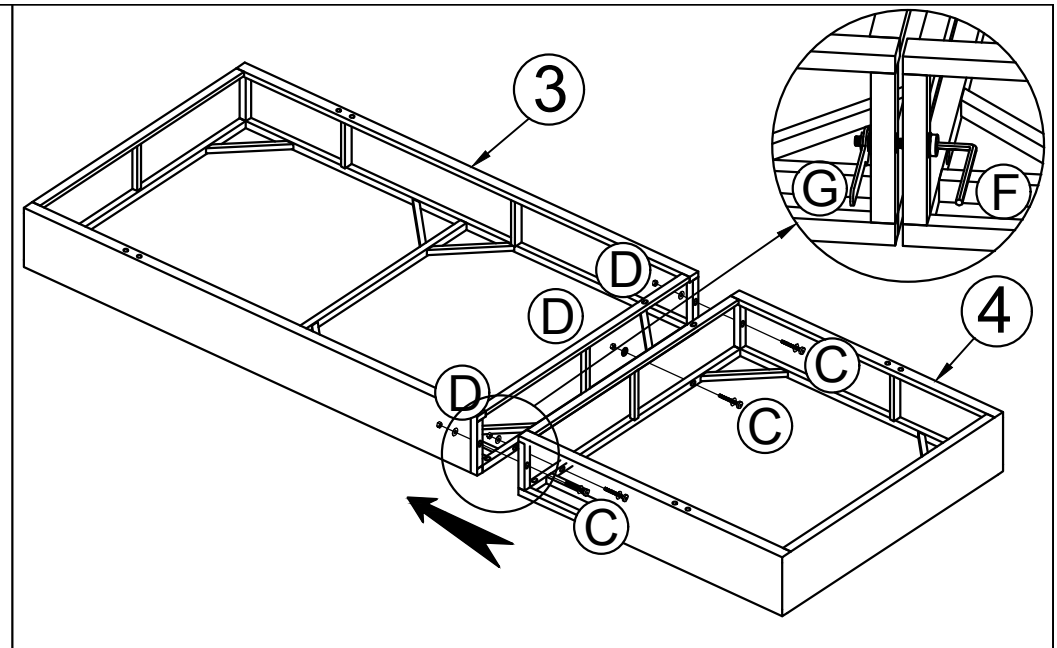

Step 4: Connect Right Bench Frame (3) & Corner Bench Frame (4), tighten Bolt (C), Flat Washer (E) & Nut (D) with Allen Key (F), Key (G).

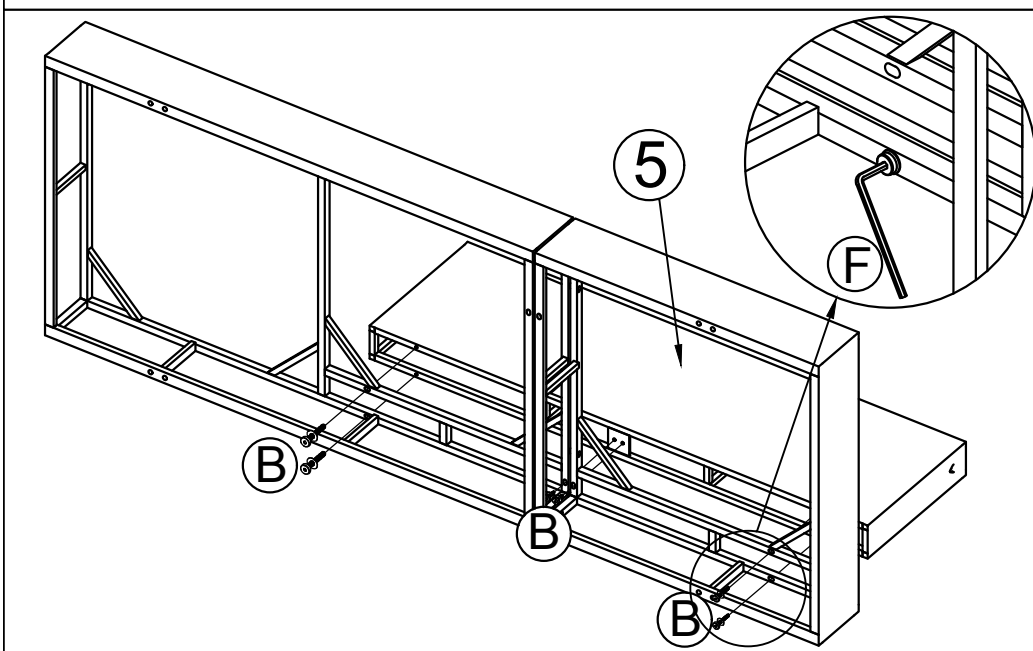

Step 5: Connect The Part from Step 4 & Back Bench Frame (5), tighten Bolt (B), Flat Washer (E) with Allen Key (F).

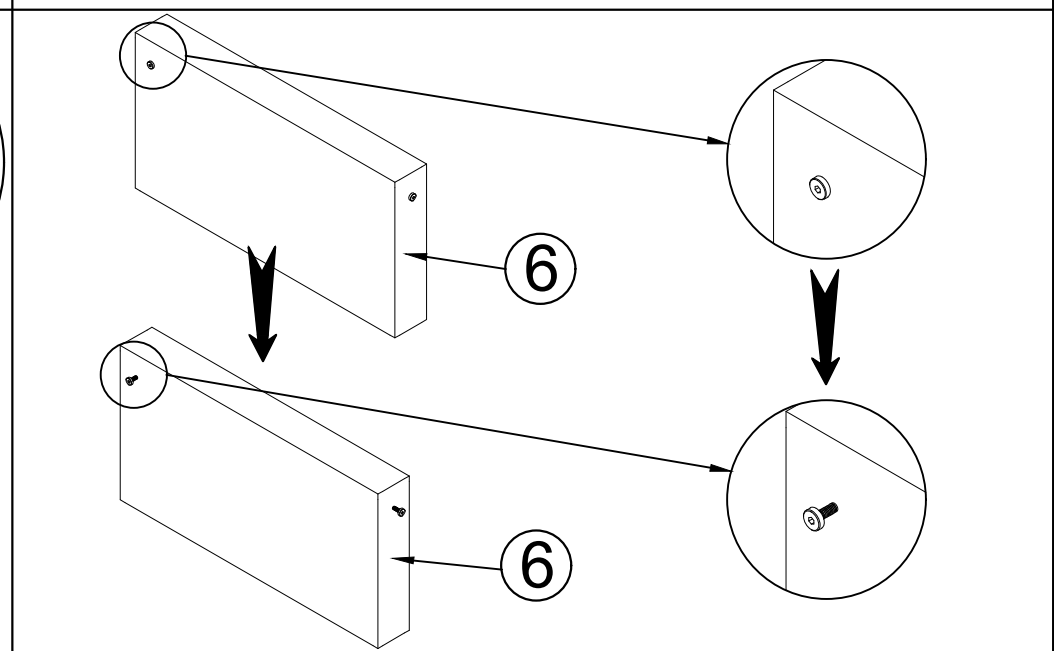

Step 6: Use Allen key to loosen Bolt on the side of Back Corner Frame (6) about 10 mm.

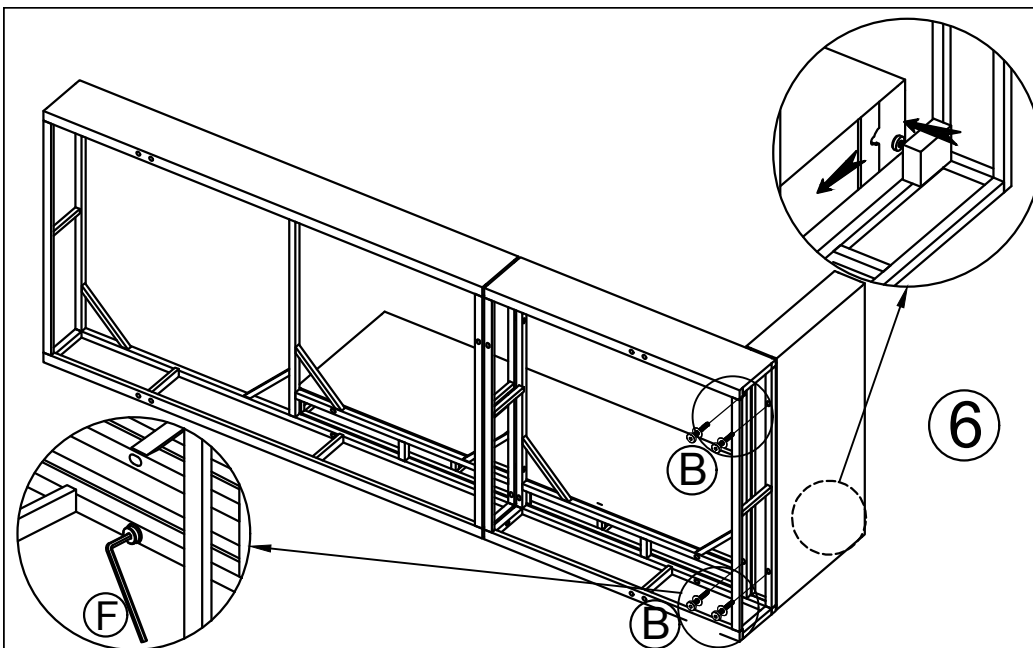

Step 7: Connect The Part from Step 5 & Back Corner Frame (6), tighten Bolt (B), Flat Washer (E) with Allen Key (F).

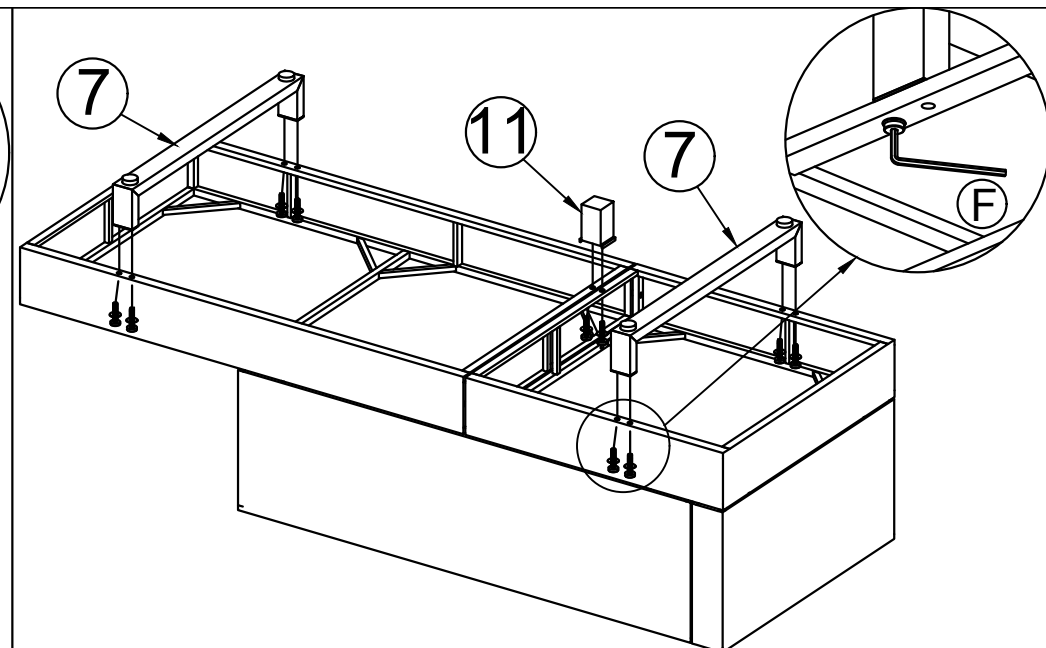

Step 8: Connect The Part from Step 7 & Leg Sofa Frame (7), Leg Middle Bench Frame (11) tighten Bolt (C), Flat Washer (E) with Allen Key (F).

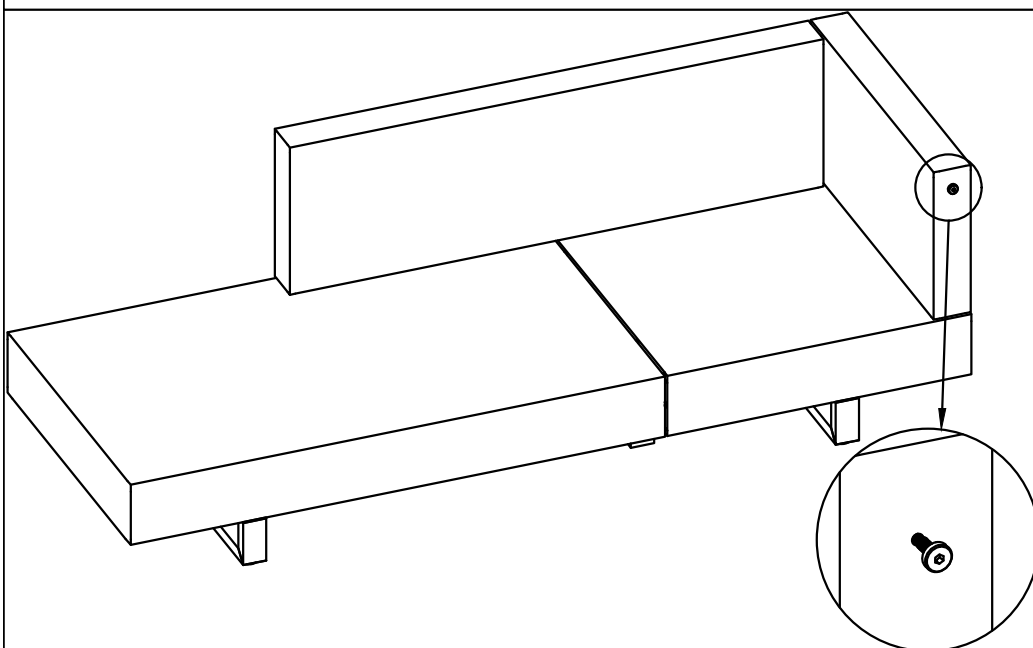

Step 9: Use Allen key to loosen Bolt on the side of Left Bench about 10 mm.

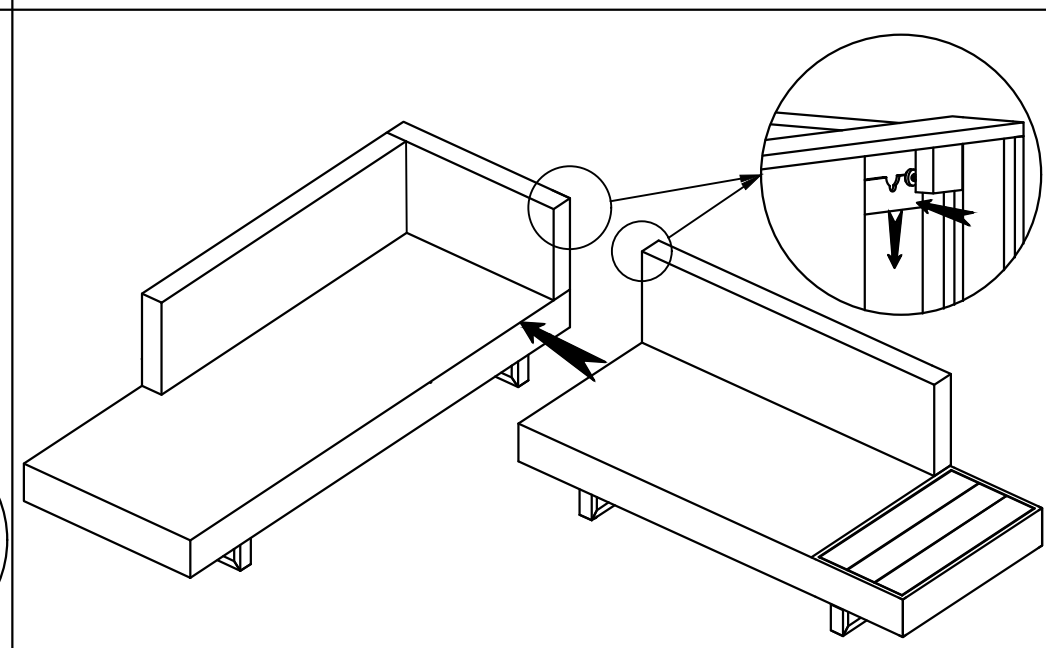

Step 10: Connect Left Bench & Right Bench.

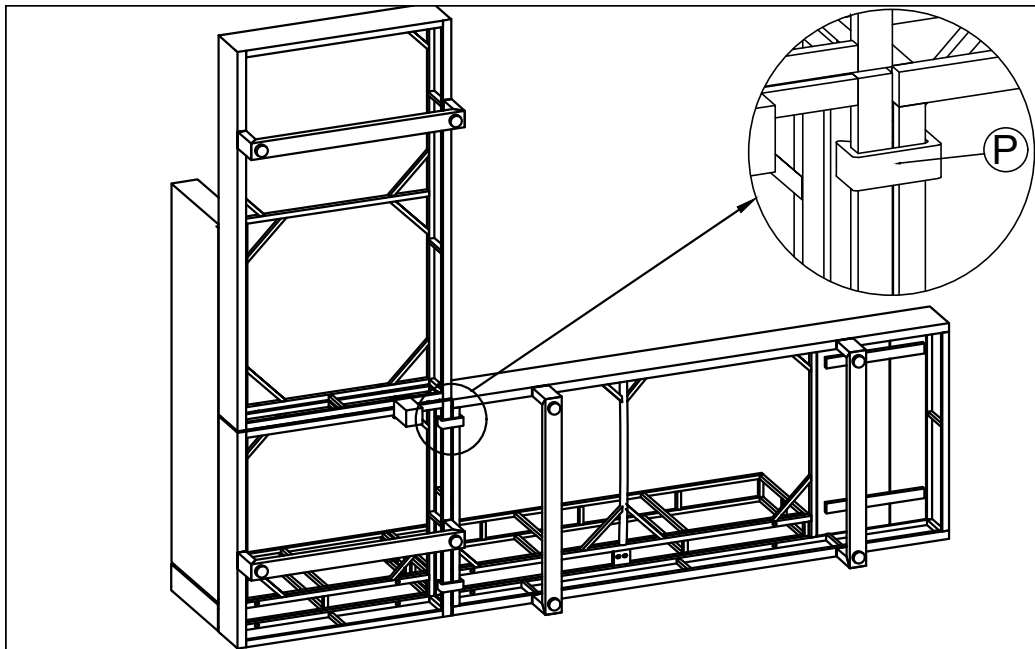

Step 10: Connect Left Bench & Right Bench with Connector (P).

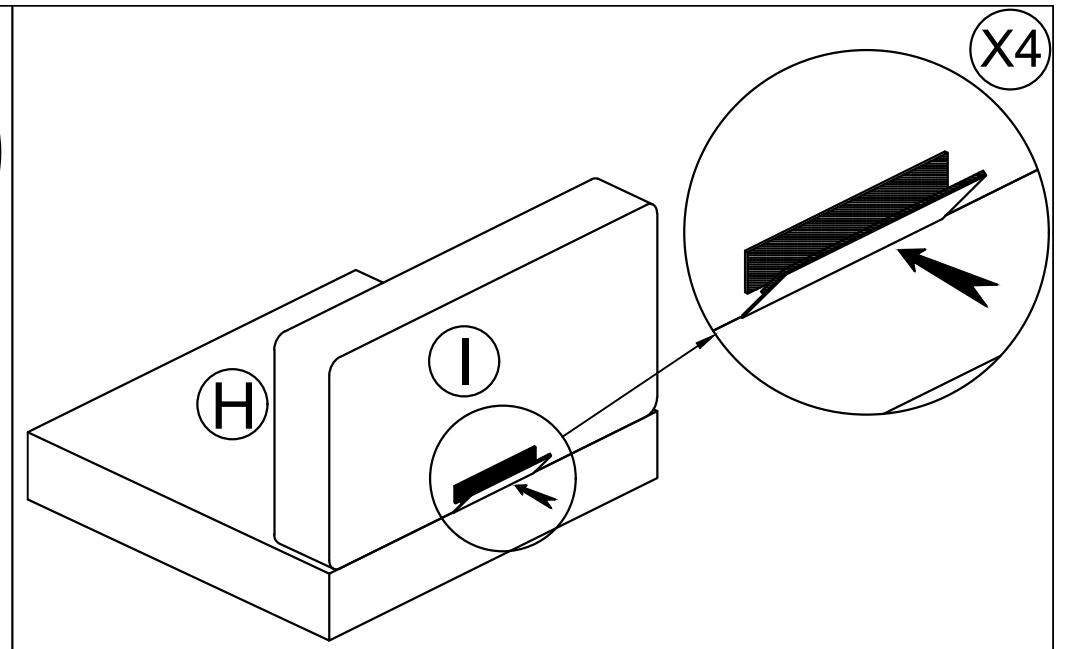

Step 11: Connect Seat Bench Cushion (H) & Back Bench Cushion (I).

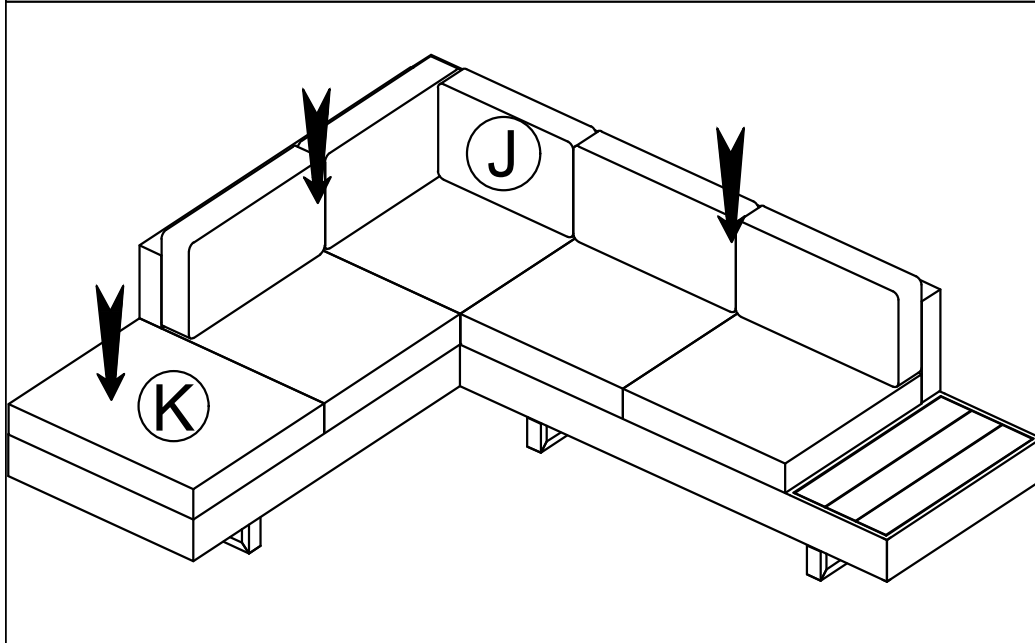

Step 12: Put The Step 11 & Seat Stool Cushion (K), Back Corner Cushion (J) on to complete the Sofa.

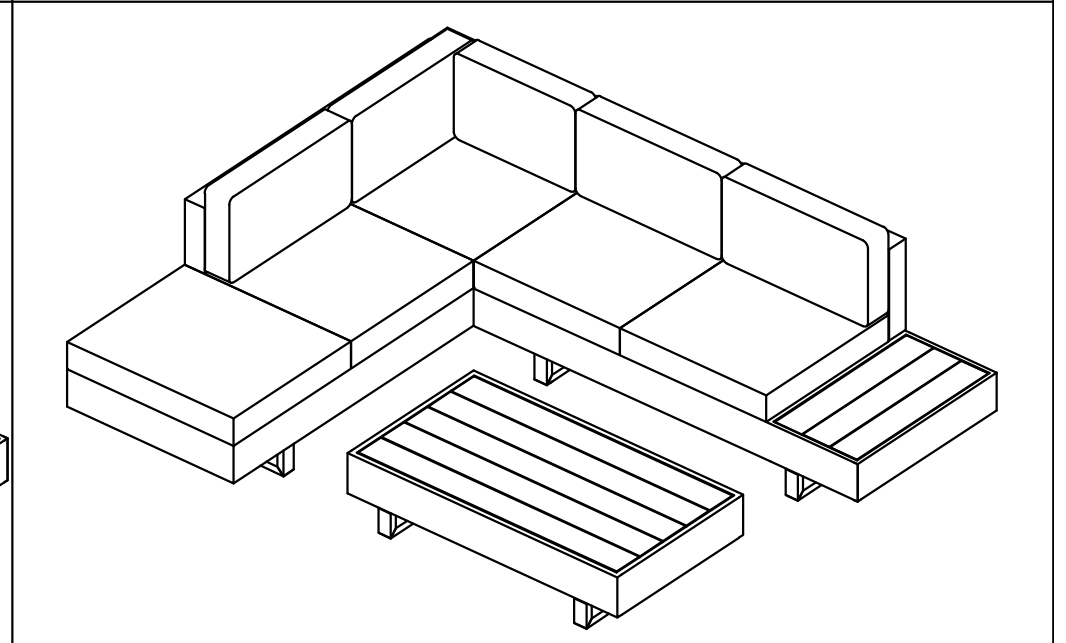

Finish Sofa