

Thank you for purchasing this quality product. Be sure to check all packing material carefully for small parts which may have come loose inside the carton during shipment. Separate, identify and count all parts and hardware. Compare with the parts list to be sure all parts are present.

IMPORTANT : PLEASE READ INSTRUCTION BEFORE STARTING THE ASSEMBLY.

"DO NOT TIGHTEN SCREWS UNTIL COMPLETELY ASSEMBLED"

"DO NOT OVERTIGHT ANY HARDWARE"

WARNING : SMALL PARTS AND HARDWARE NOT FOR CHILDREN UNDER 3 YEARS. ADULT ASSEMBLY REQUIRED.

TABLE OF CONTENTS

HARDWARES LIST	PAGE 2
PARTS LIST	PAGE 3
PARTS' LOCATION	PAGE 4
ASSEMBLY STEPS	PAGE 5 - 6
ASSEMBLY COMPLETED	PAGE 7

ASSEMBLY TOOLS REQUIRED

1. Screwdriver (not provide)

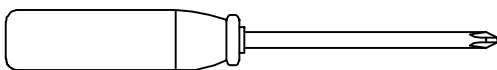



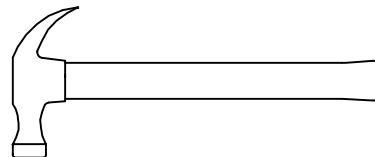



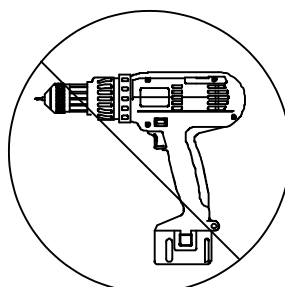

2. Hammer (not provide)

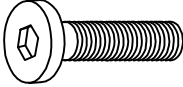

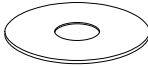
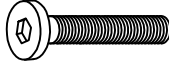

Skip the power trip this time.



HARDWARES LIST

ITEM	DESCRIPTION	DRAWING	QTY
A	JCBC SCREW M8 x 35MM		4 PCS
B	SPRING WASHER M8 x 14MM		4 PCS
C	FALT WASHER M8 x 22MM		4 PCS
D	JCBC SCREW M6 x 50MM		4 PCS
E	FALT WASHER M6 x 19MM		8 PCS
F	SPRING WASHER M6 x 12MM		4 PCS
G	HEX NUT		4 PCS
H	M4 ALLEN KEY (65MM)		1 PC
I	M5 ALLEN KEY (65MM)		1 PC

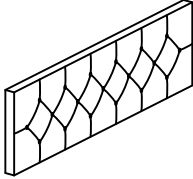
PARTS LIST

ITEM	DESCRIPTION	DRAWING	QTY
1	HEADBOARD		1 PC
2	HB LEG		2 PCS

80090 FB ASSEMBLY INSTRUCTION

PARTS ' LOCATION

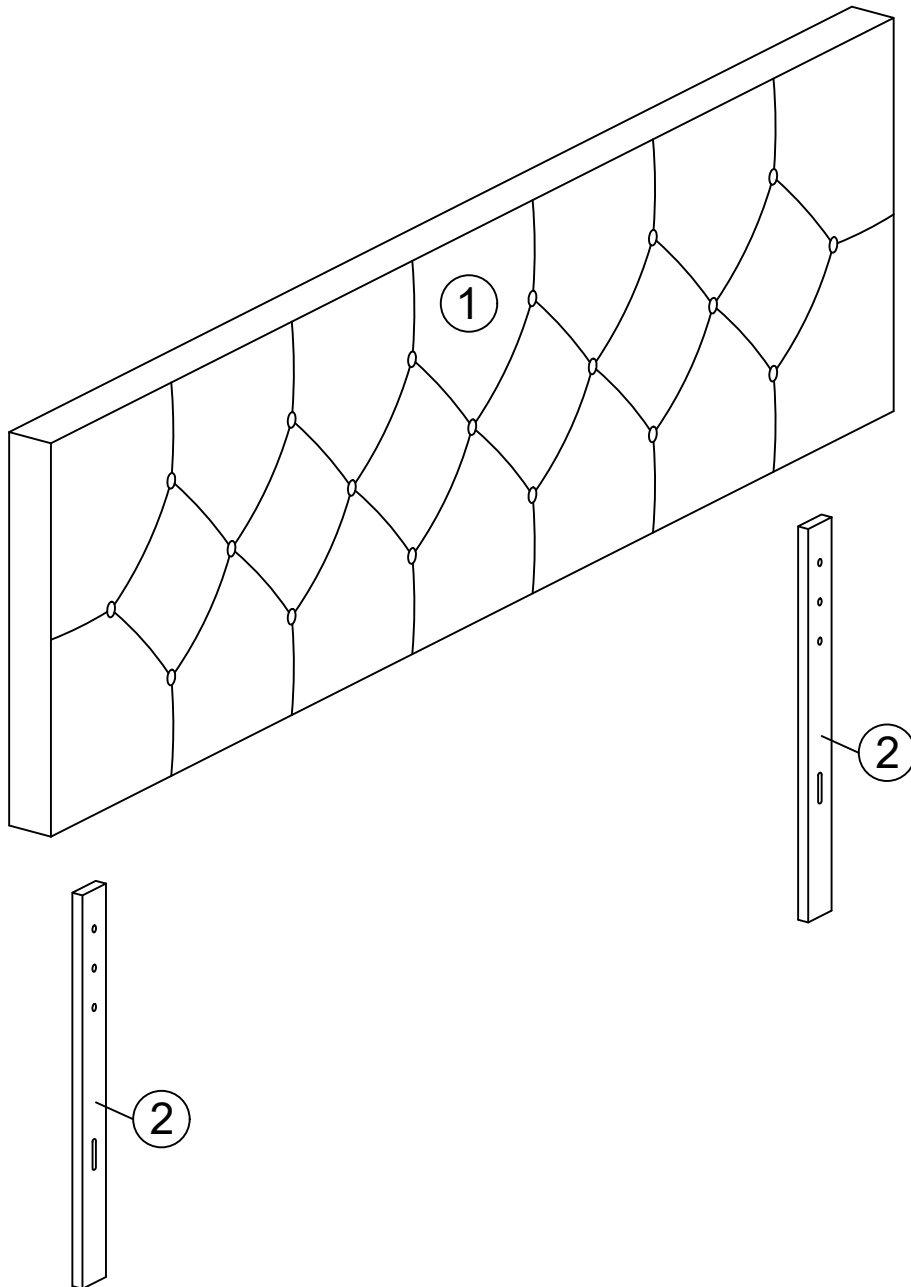

STEP 1

Insert 8pcs (A) to combine 2pcs (4) to (2) and (3) as shown.

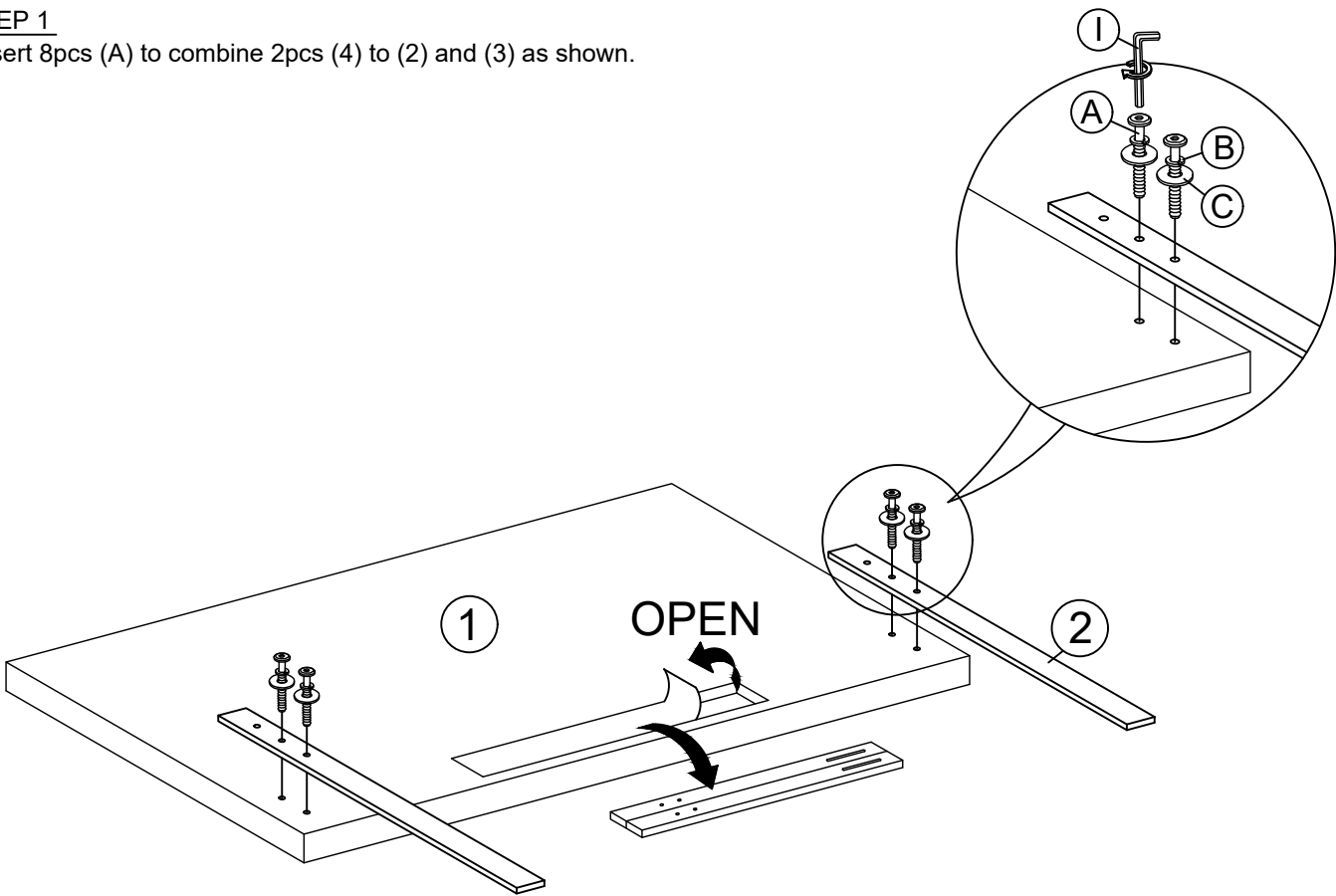

STEP 2

Insert 4pcs (D) to fix the (5) to (4) as show.

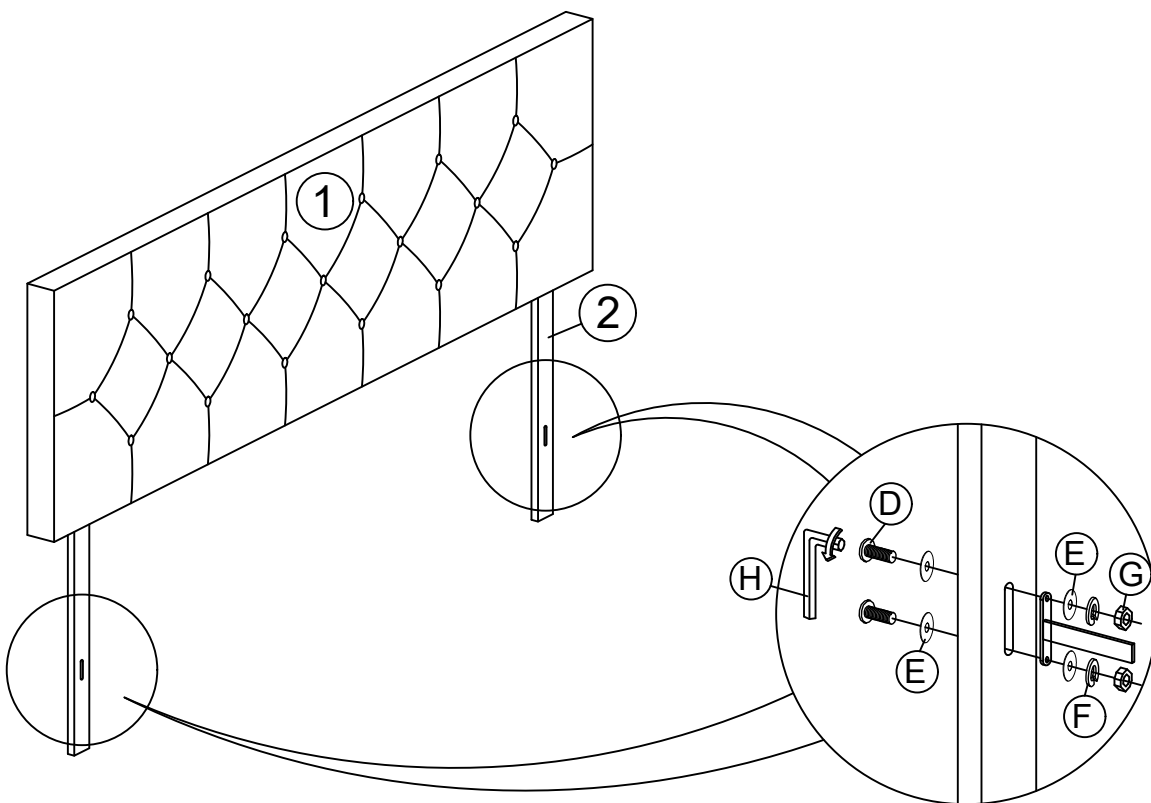

STEP 5

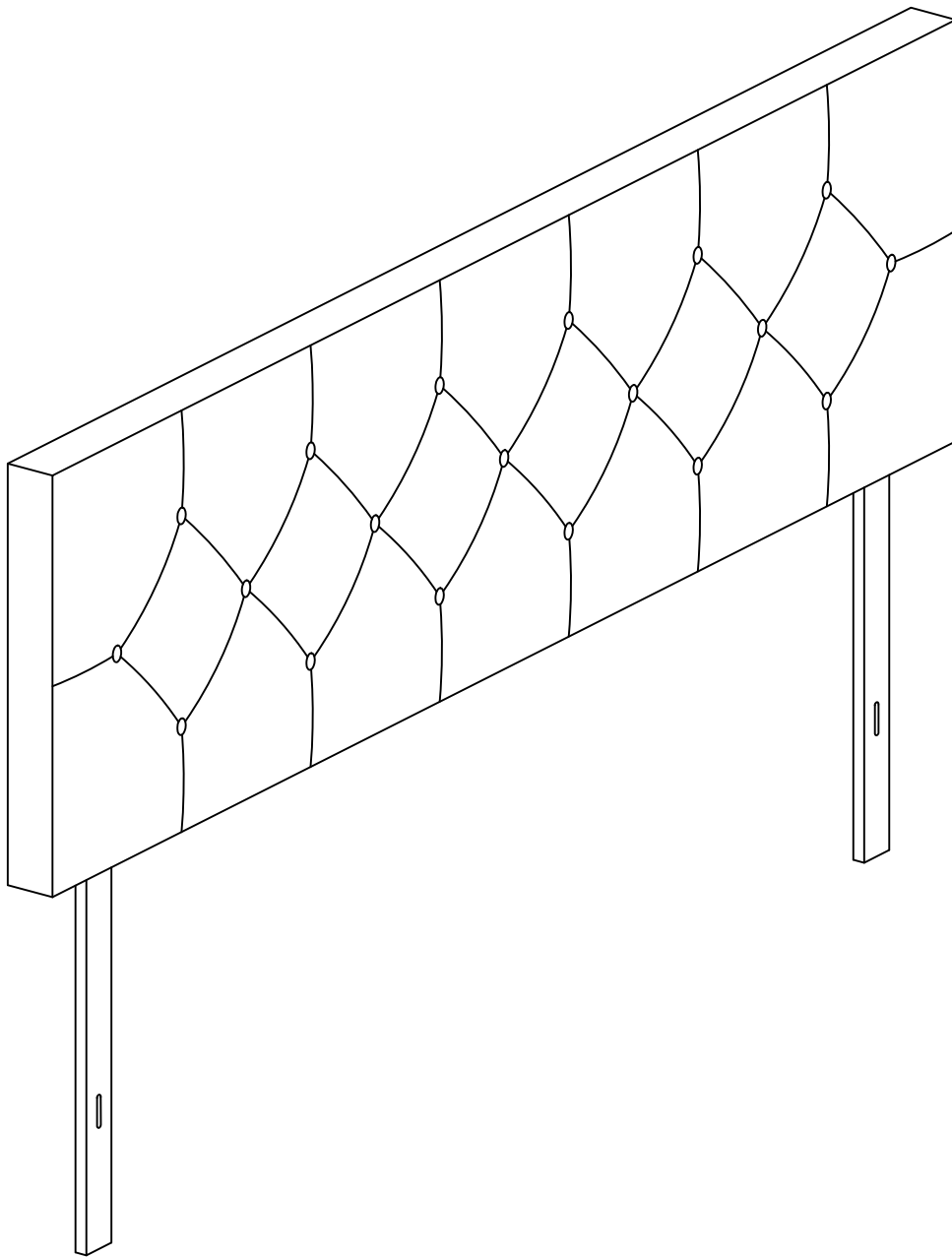

ASSEMBLY COMPLETED