

Assembly Instructions

CAUTION: You must read this **Assembly Instructions** before you proceed.

Please look in the **Table Top** for hardware packs.

Table

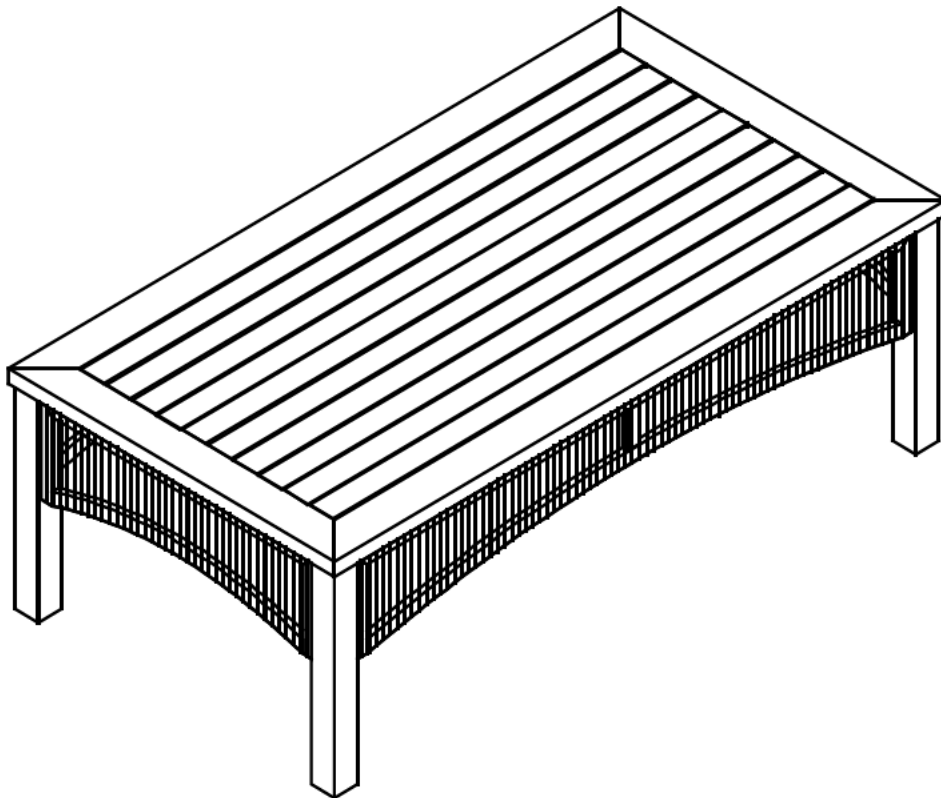

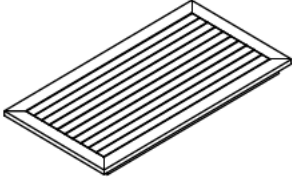
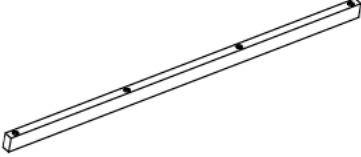
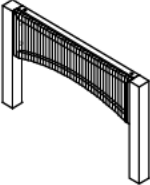
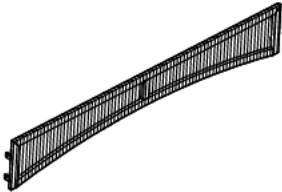

CAUTION: This Table is NOT a TOY.
Keep your child / children at bay in the process of assembly.
For turning the Table and to prevent damage to the Table, 02 people may be needed to execute this action.

Part List

Label	Picture	Description	QTY
G		Table Top	1
H		Support Bar	2
I		Apron	2
J		Leg Frame	2

Hardware

Label	Picture	Description	QTY
③		Screws (M6x45mm)	13
④		Screws (M6x20mm)	9
⑤		Allen Wrench	1

Assembly Preparation

Before Beginning Assembly:

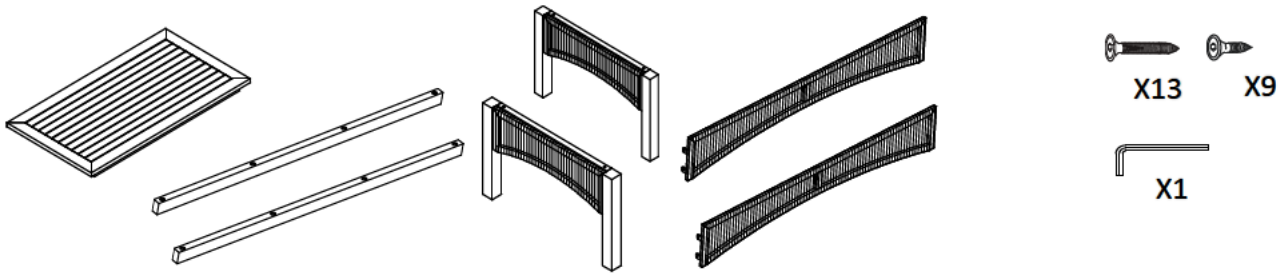

- Read instructions, cover to cover-



- Have 2 adults on hand for assembly-



- Do not assemble on flooring or carpet-



- Assemble on a clean non-marring surface (packing foam)-



- Save all packaging until finished-

Assembly Steps

Overview

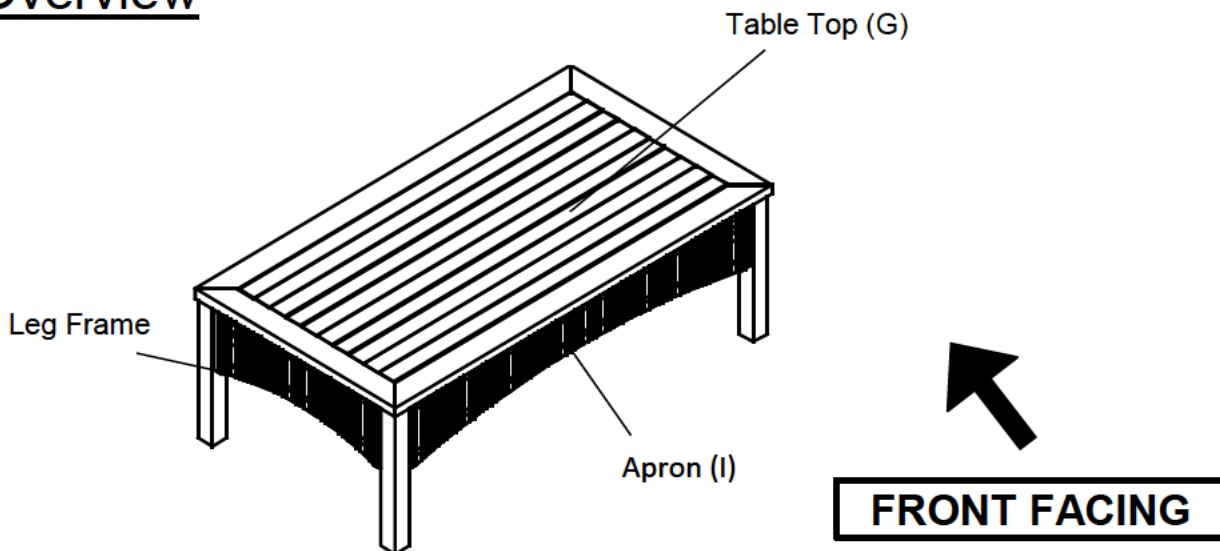

This Table has multiple parts and may require up to 35 minutes to assemble. To give you an overview of the Table parts, the above picture is to help you put the various parts into perspective. Please read through the instructions herebelow to familiarise yourself with the parts and steps before assembly.

Step 1

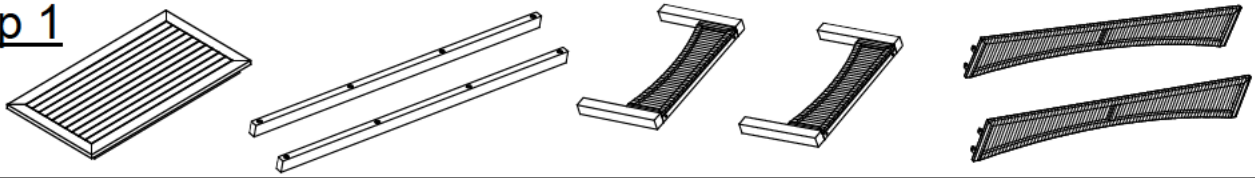

Unpack and place all parts on a clean, non-marring surface.

Step 2

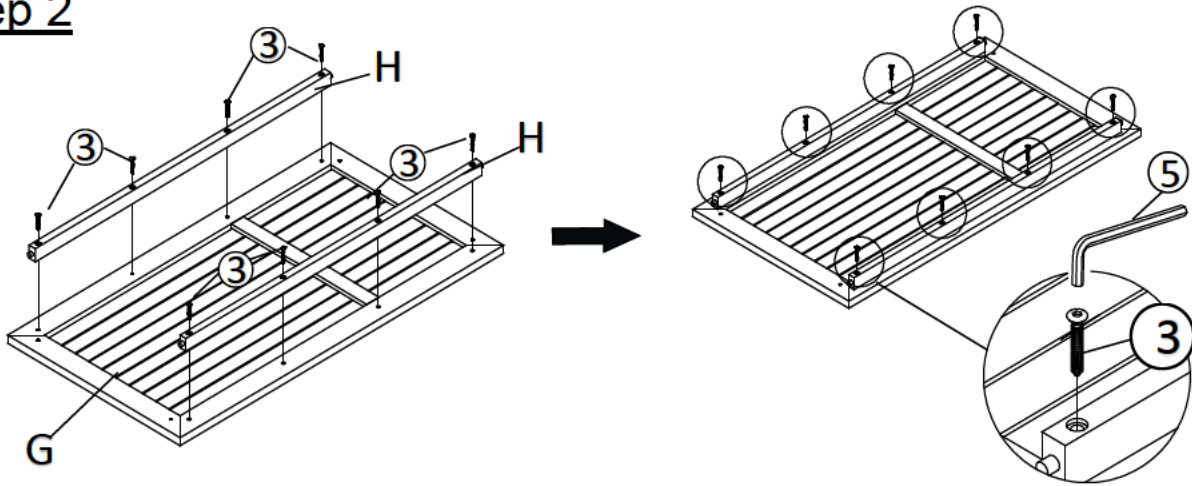

With assistance from your adult partner(s), turn the Table Top (G) (bottom-side up) and place it on a clean, soft surface to avoid any scratches or damage to the product.

Attach the Support Bar (H) to the Table top (G), then secure it using the Screws (3) and Allen Wrench (5) as shown above.

Repeat the same process with the remaining Support bar (H).

Do not fully tighten the Screws at this time.

Step 3

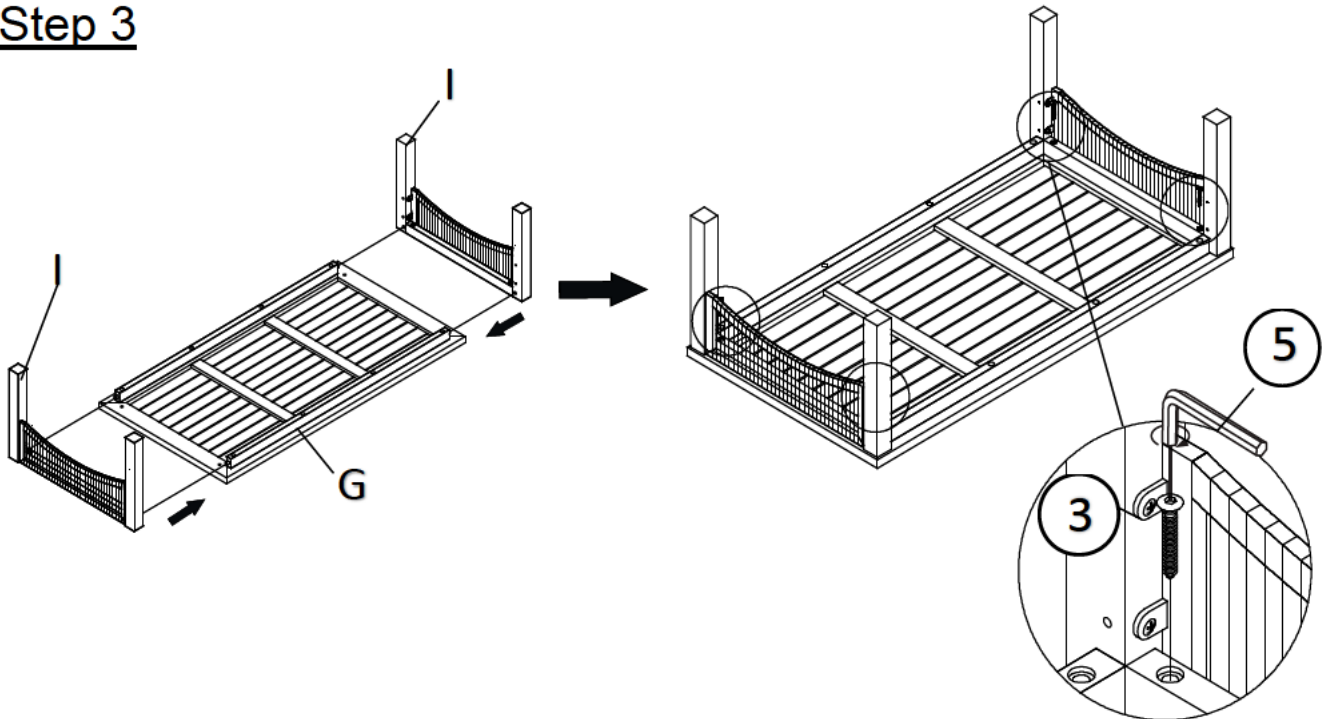

With assistance from your adult partner(s), loosely affix one Leg Frame (I) onto the Table top (G), then screw it using the Screws (3) and Allen Wrench (5) as shown above.

Repeat the same process with the remaining Leg Frame (I).

Do not fully tighten the Screws at this time.

Step 4

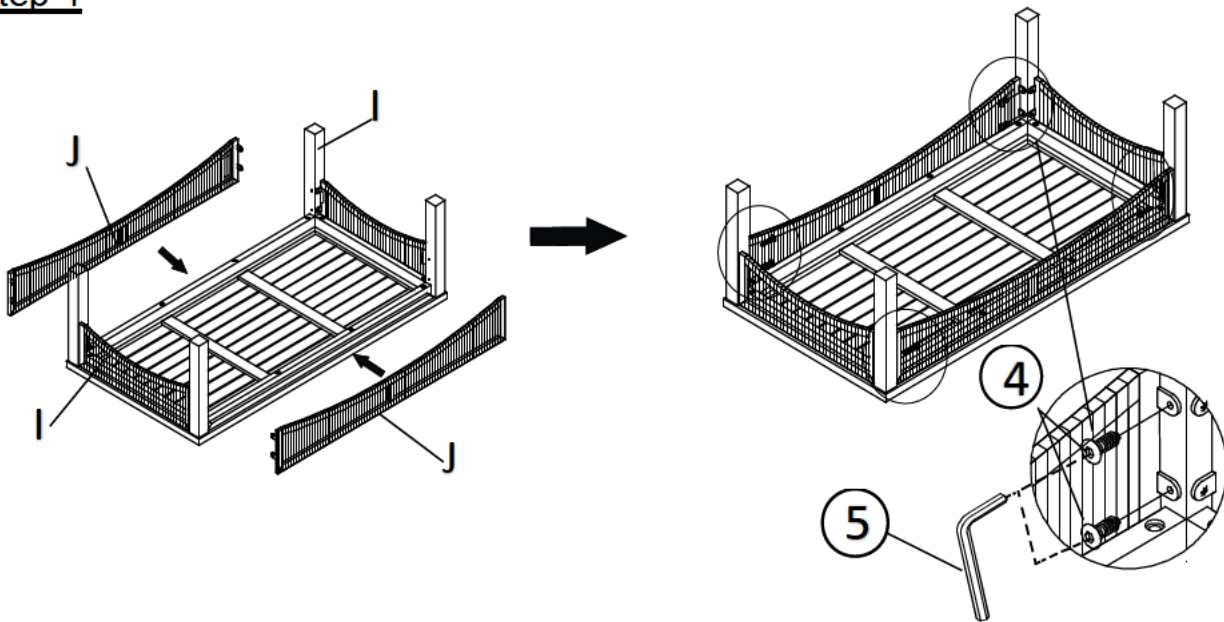

With assistance from your adult partner(s), attach the Apron (J) to the Leg Frame (I), then secure it using the Screws (④) and Allen Wrench (⑤) as shown above. Repeat the same process with the remaining Apron (J)

Do not fully tighten the Screws at this time.

Step 5

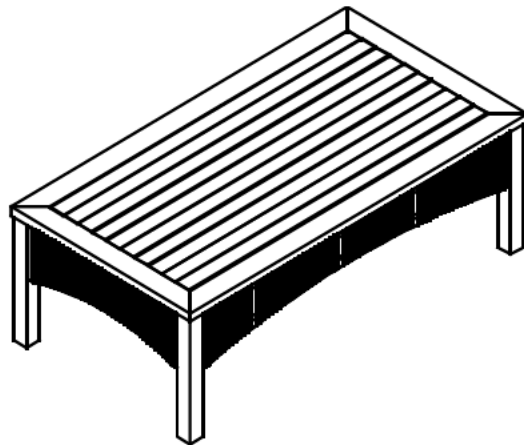

With assistance from your adult partner(s), turn the Table right side up. Exert pressure floorwards, onto the Table with both your hands. This pressure will help the Legs and Table Top reach full alignment status. Check for wobbles on a LEVEL surface.

If no wobbles are found proceed to tighten the Screws in a sequential manner, until evenly secured.

When tightening the Screws tighten sequentially.





















Caution: Do not tighten any Screws fully and then move on towards the next one.

If there are still wobbles after tightening, loosen the Screws and execute the same above process.

Your Table is ready to be used.

This Table can only be used on a flat, level surface.

Care & Maintenance

-   ● Do not put hot items directly on furniture surface
 -   ● Do not clean furniture with harsh cleansers or polish.
 -   ● To obtain the longest lifespan of your outdoor products, minimizing exposure to direct sunlight is recommended.
 -   ● Children should not climb or jump on the furniture.
 -   ● Do not write on furniture without a padded barrier to protect the surface.
 -   ● To obtain the longest lifespan of your outdoor products, avoid extended and lengthy exposure to rain, snow, and direct sunshine. Whenever possible cover the product and /or place under patio or awnings.
 -   ● Not for commercial use. For residential use only .
 -   ● Stains may be removed with mild soap solution and damp cloth.
 -   ● Keep away from sources of ignition.
-
-   ● Dust and pick-up spills using a clean, non-colored, lint-free cloth.