

Installation & Assembly

DIMENSIONS

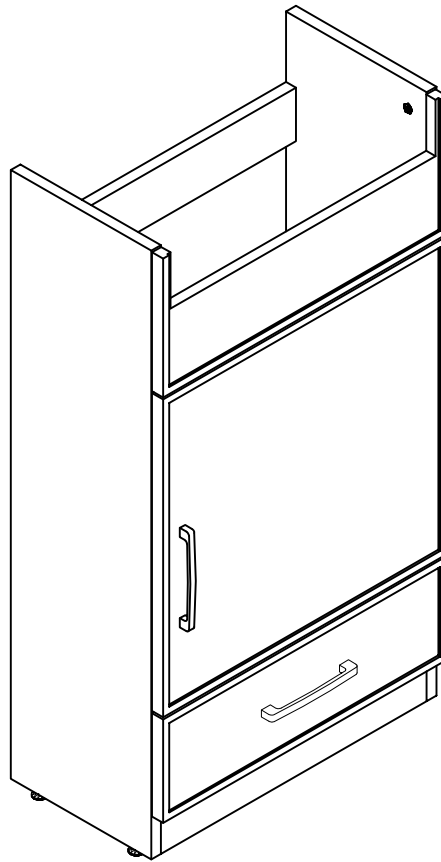

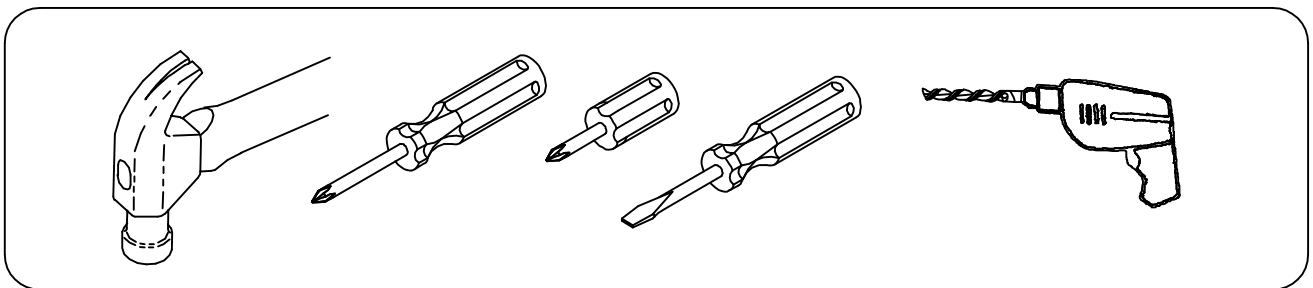





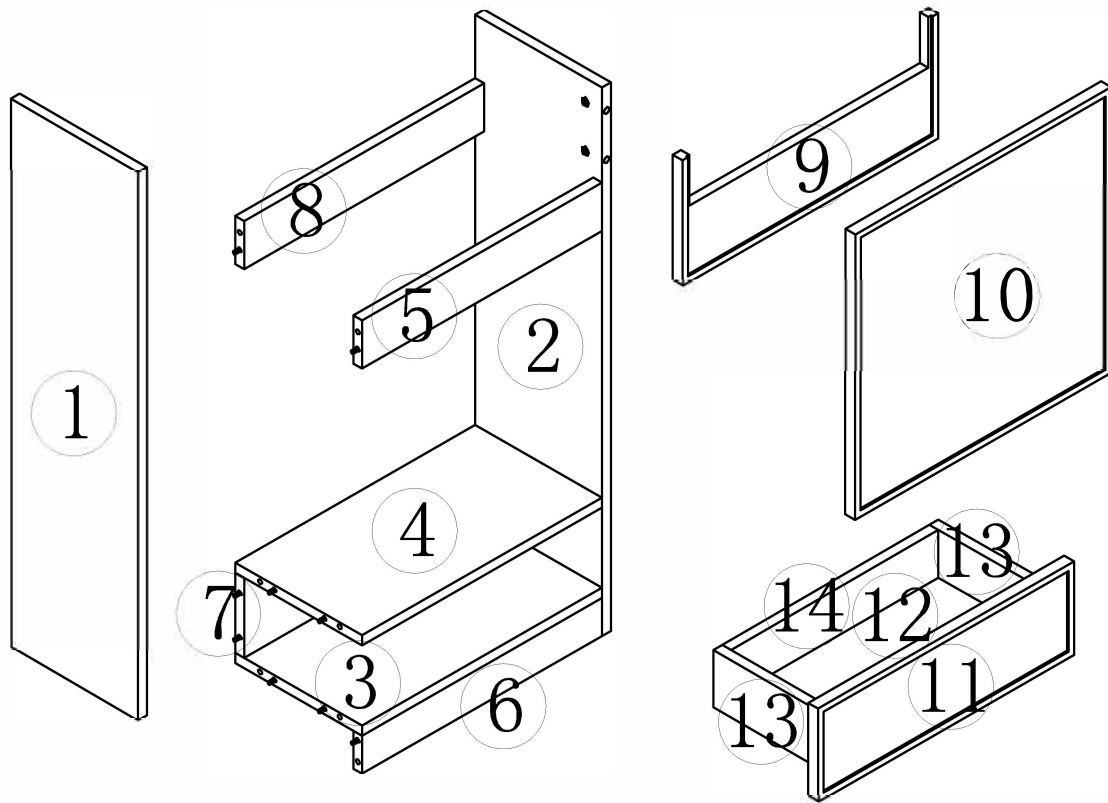









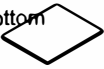





YOU MAY NEED (NOT SUPPLY)





ASSEMBLY DIAGRAM



| PARTS LIST | | | | | |
|------------|--|-----|----|--|-----|
| NO | DESCRIPTION | QTY | NO | DESCRIPTION | QTY |
| ① | Left side panel  | 1 | ⑧ | rear pull-up bar  | 1 |
| ② | Right side panel  | 1 | ⑨ | Front baffle panel  | 1 |
| ③ | Bottom panel  | 1 | ⑩ | Right door panel  | 1 |
| ④ | laminate  | 1 | ⑪ | drawer panel  | 1 |
| ⑤ | front pull-up  | 1 | ⑫ | drawer bottom  | 1 |
| ⑥ | Front bottom bar  | 1 | ⑬ | drawer side panel  | 2 |
| ⑦ | rear drop down  | 1 | ⑭ | drawer back panel  | 1 |

| PARTS LIST | | | | | |
|--|---|-----|----|---|-----|
| HARDWARE LIST | | | | | |
| NO | DESCRIPTION | QTY | NO | DESCRIPTION | QTY |
| A | Three-in-one eccentric wheel  | 26 | F | 4*16mm screw  | 24 |
| B | Three-in-one connecting rod  | 26 | G | 4*20mm screw  | 4 |
| C | Three-in-one sticker  | 26 | H | Door handle  | 1 |
| D | 8*40mm wood dowel pins  | 18 | I | Drawer handle  | 1 |
| E | Drawer slides  | 2 | J | Door hinge  | 2 |
| CAUTION: Please confirm the parts list before installation | | | | | |

STEP 1

| HARDWARE LIST | |
|--|---|
| Three-in-one connecting rod B  26PCS |  |

1. Put the three-in-one connecting rod in the 10mm hole of the following panels and tighten them with a cross screwdriver or an electric tool.

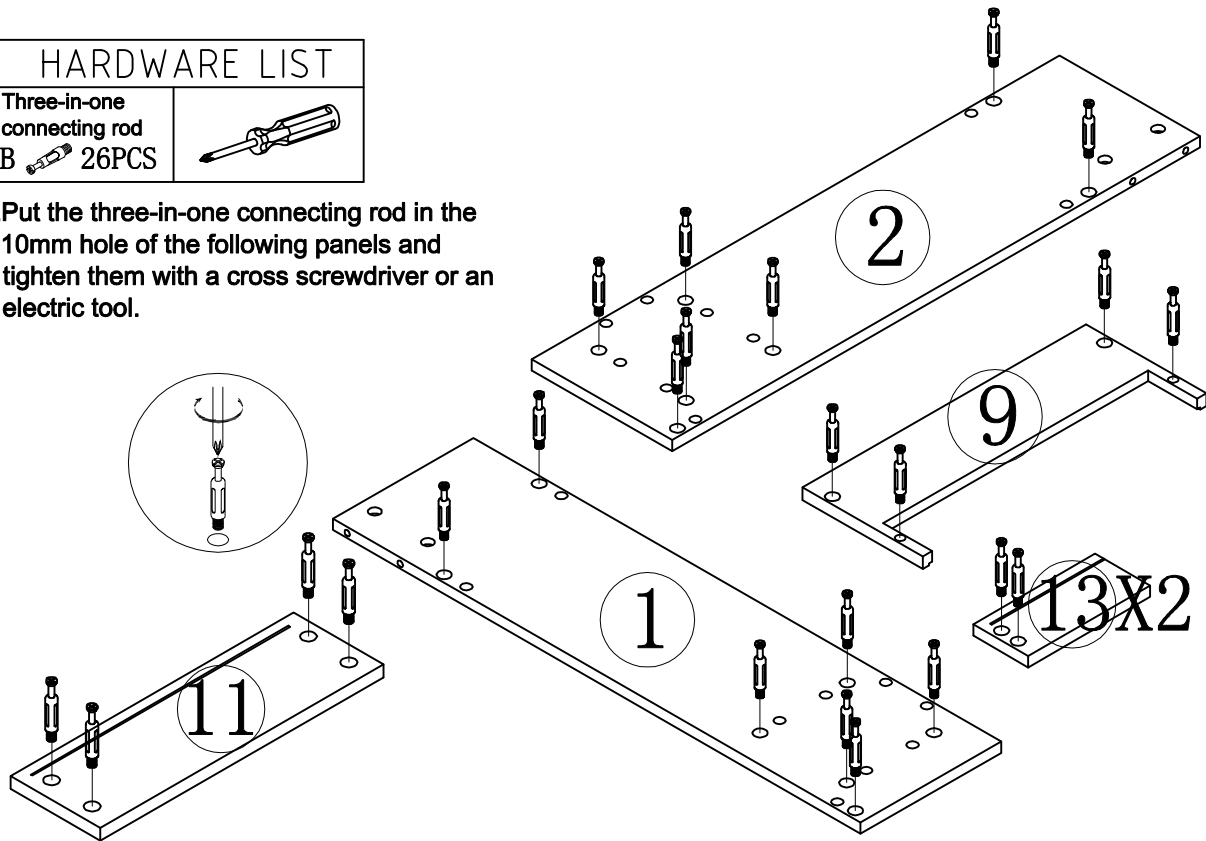

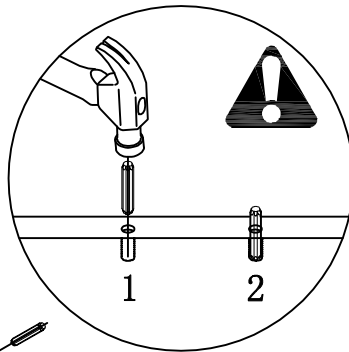

STEP 2



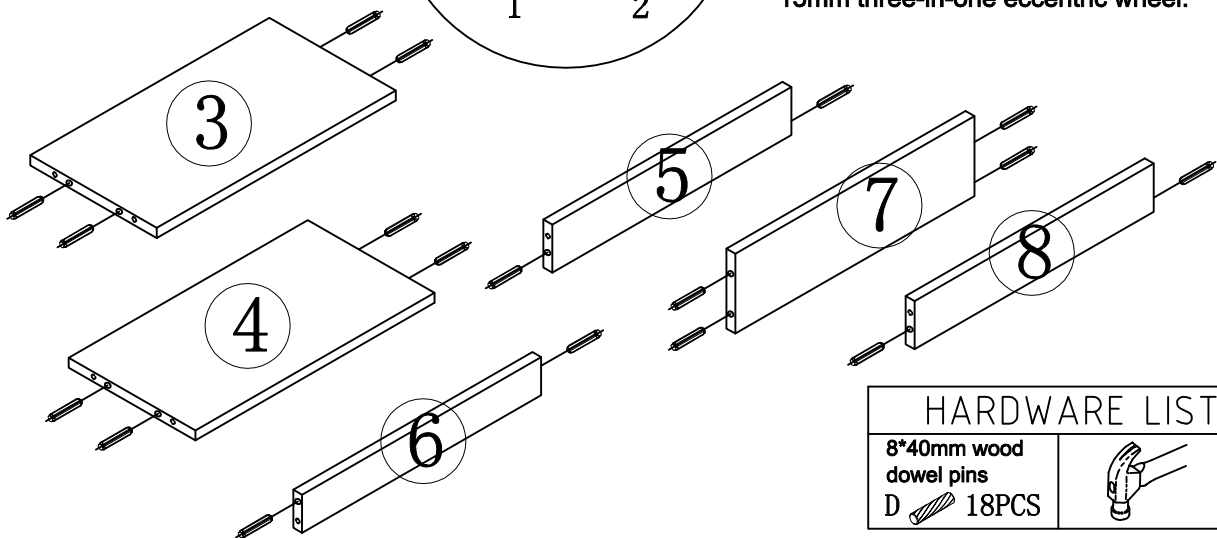

1. Strike the 08*40mm wood dowel pin into the 8mm hole of the above panels with an iron hammer. Please note that the hole of the three-in-one connecting rod should also be 8mm. The hole of the three-in-one connecting rod connects to the hole of 15mm three-in-one eccentric wheel.

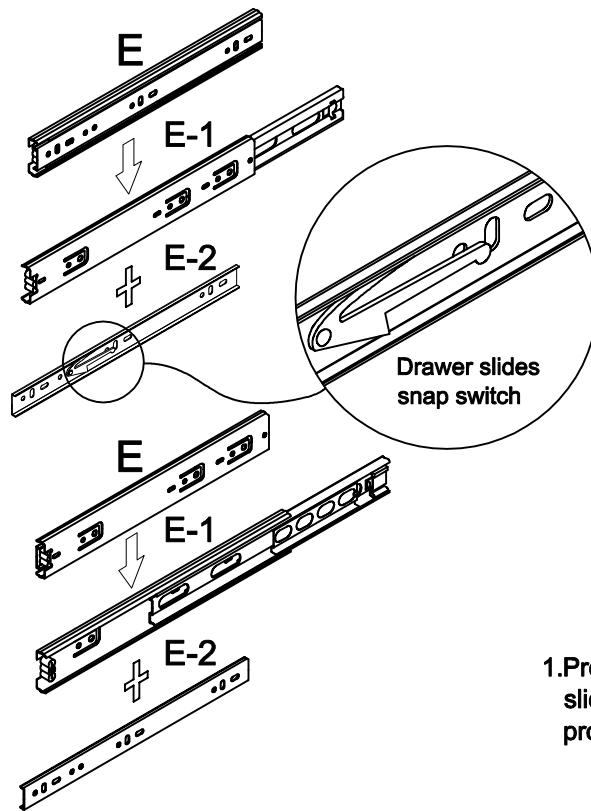

| HARDWARE LIST | |
|---|---|
| 8*40mm wood dowel pins D  18PCS |  |

STEP 3





| HARDWARE LIST | |
|--|---|
| Drawer slides |  |
| E  2PCS | |

1. Press the slide snap switch, disassemble slide blocks and put them in a place properly for further use.

STEP 4

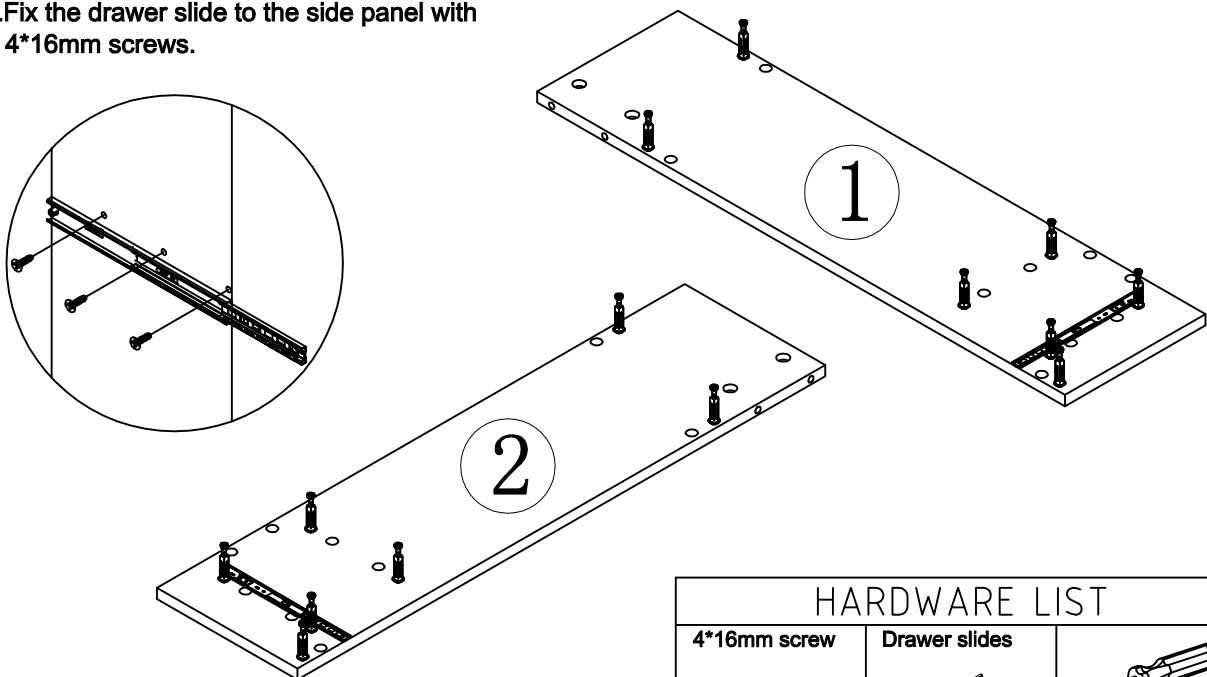
1. Fix the drawer slide to the side panel with 4*16mm screws.

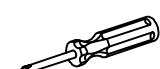

| HARDWARE LIST | | |
|--|--|---|
| 4*16mm screw | Drawer slides |  |
| F  6PCS | E-1  2PCS | |

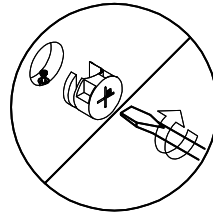
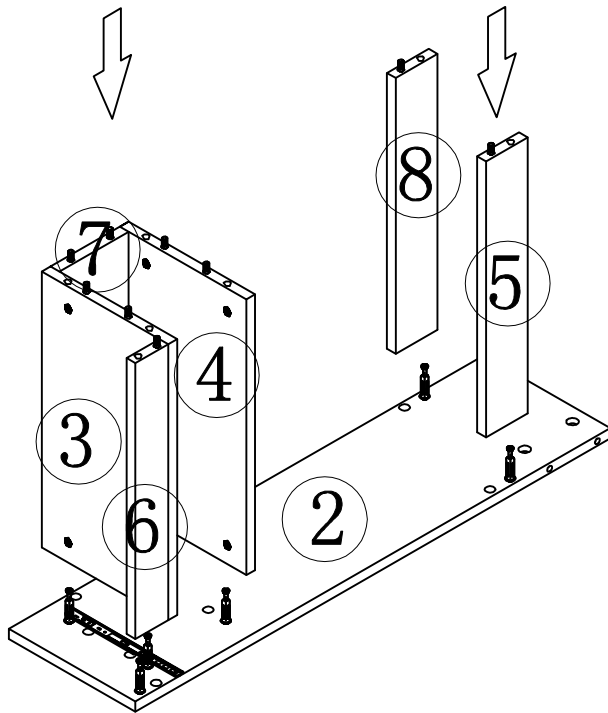

STEP 5

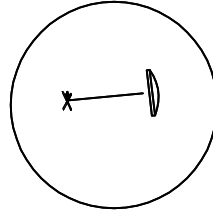

1. Connect No. 3-4-5-6-7-8 panel to No.2 panel tightly with the three-in-one eccentric wheel.



2. Cover the mounting hole of the eccentric wheel with a three-in-one sticker.

| HARDWARE LIST | | |
|---|---|--|
| Three-in-one eccentric wheel A  7PCS | Three-in-one sticker C  7PCS |  |

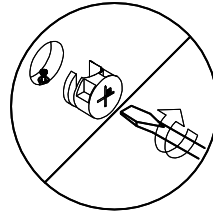
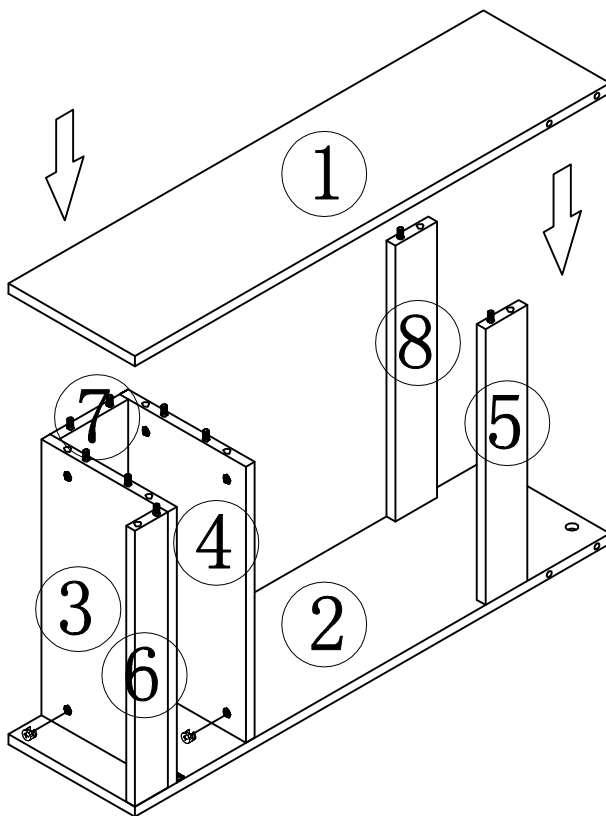

STEP 6

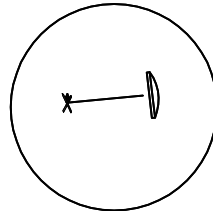

1. Connect No. 1 panel to No. 3-4-5-6-7-8 panel tightly with the three-in-one eccentric wheel.



2. Cover the mounting hole of the eccentric wheel with a three-in-one sticker.

| HARDWARE LIST | | |
|--|--|---|
| Three-in-one eccentric wheel A  7PCS | Three-in-one sticker C  7PCS |  |

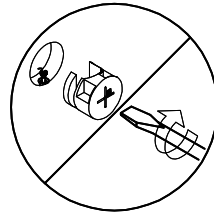
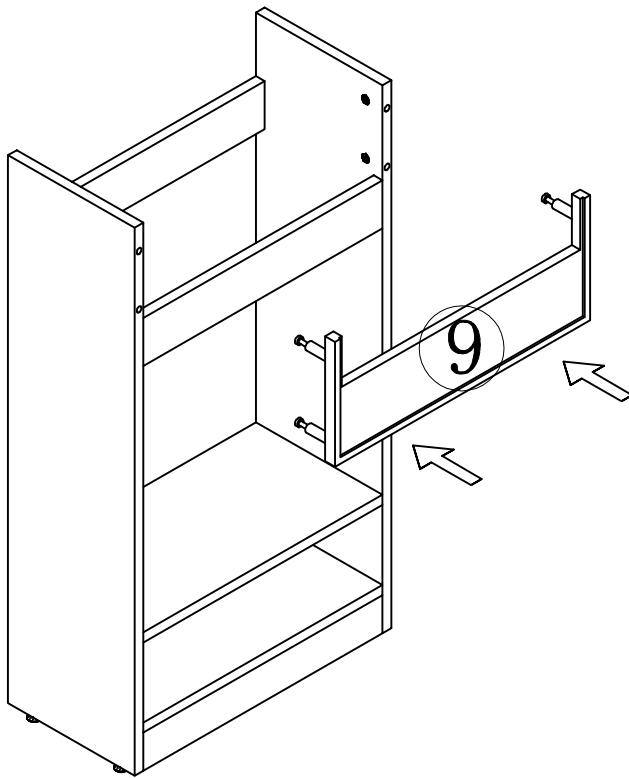

STEP 7

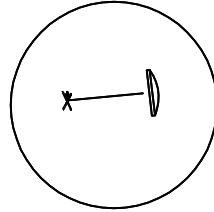

1. Install No.9 panels with the three-in-one eccentric wheel tightly.



2. Cover the mounting hole of the eccentric wheel with a three-in-one sticker.

| HARDWARE LIST | | |
|---|---|--|
| Three-in-one eccentric wheel A  4PCS | Three-in-one sticker C  4PCS |  |

STEP 8

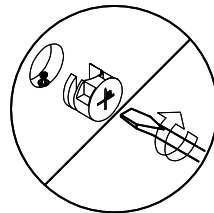
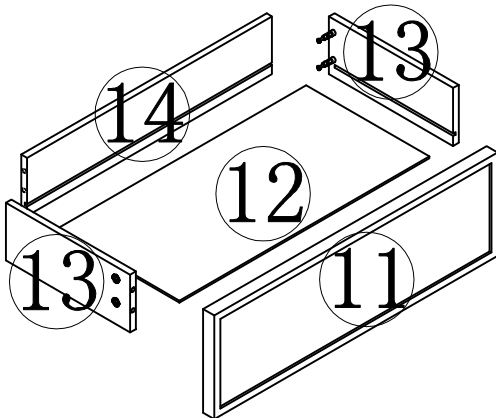

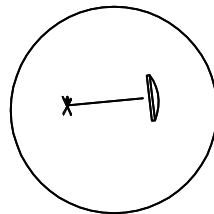

1. Install No. 11-12-13-14 panels with the three-in-one eccentric wheel tightly.

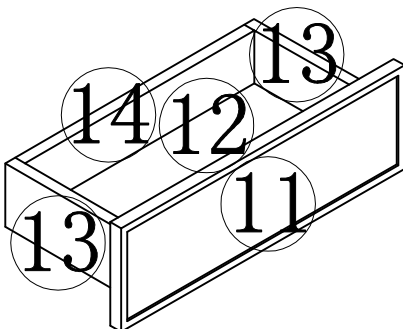

2. Cover the mounting hole of the eccentric wheel with a three-in-one sticker.



| HARDWARE LIST | | |
|--|--|---|
| Three-in-one eccentric wheel A  8PCS | Three-in-one sticker C  8PCS |  |

STEP 9

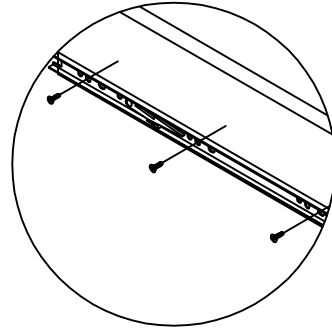
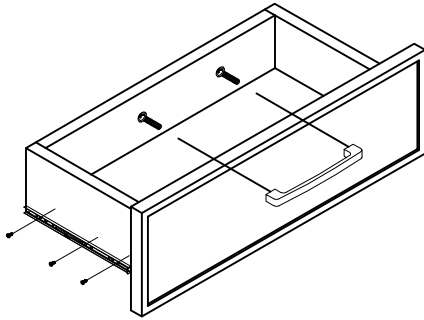

1. Lock the spare drawer slide block to the drawer.
2. Install the drawer handle with 4*20 handle screws.

| HARDWARE LIST | | |
|---------------|---------------|--|
| 4*16mm screw | Drawer slides | |
| F 6PCS | E-2 2PCS | |
| 4*20mm screw | Drawer handle | |
| G 2PCS | I 1PCS | |

STEP 10

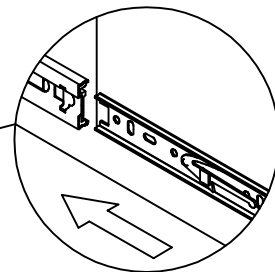
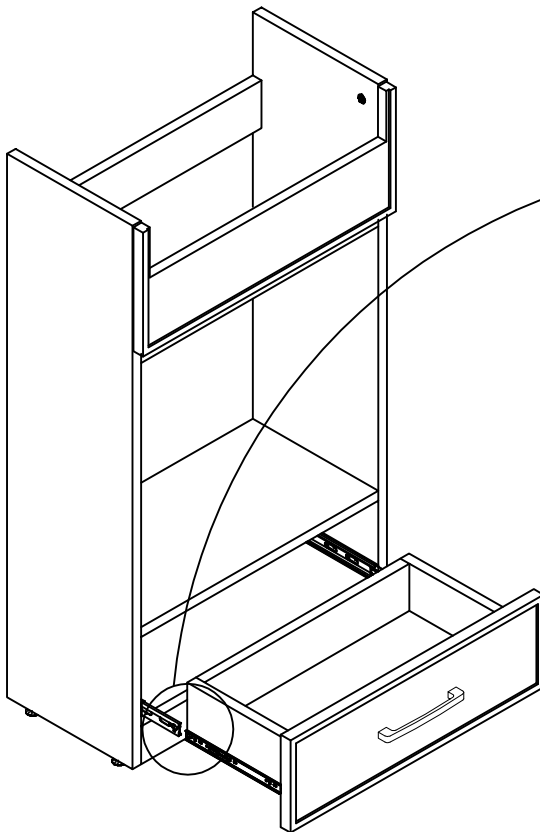

1. Align slide block with the trough on the guide rail, press the snap switch and press it forward to install the drawer.

2. Install drawer handles.

STEP 11

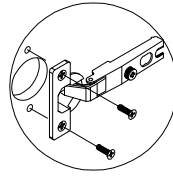
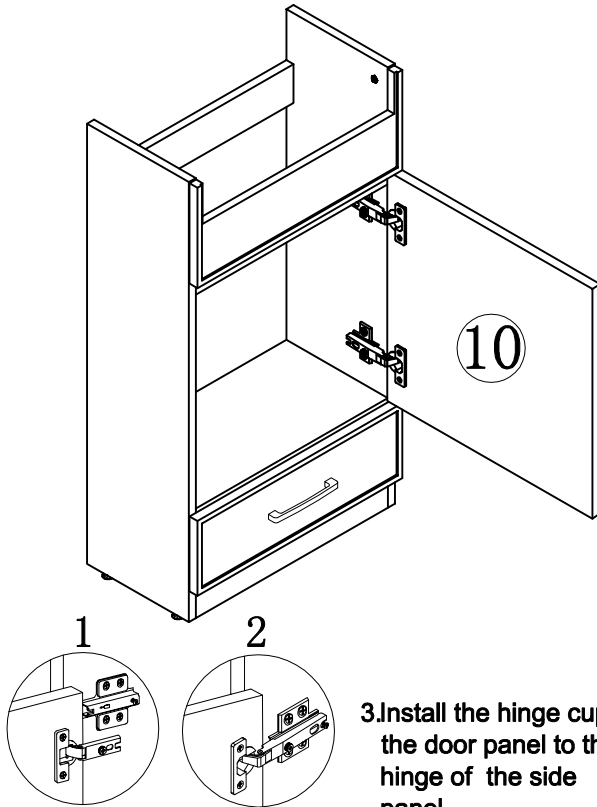

1. Install the hinge cup to the door panel with 4*16mm screws.

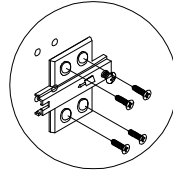

2. Install the hinge to the side panel with 4*16mm screws.

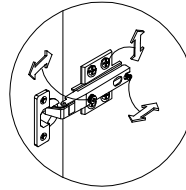

4. Adjust the door panel clearance.

3. Install the hinge cup on the door panel to the hinge of the side panel.

| HARDWARE LIST | | |
|--|---|--|
| 4*16mm screw | Door hinge |  |
| F  12PCS | K  2PCS | |

STEP 12

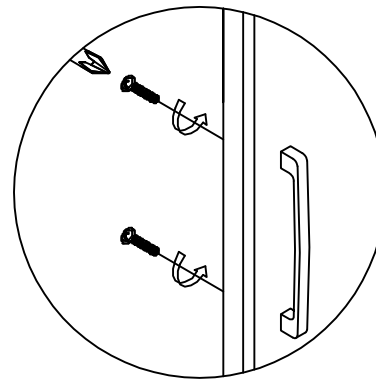
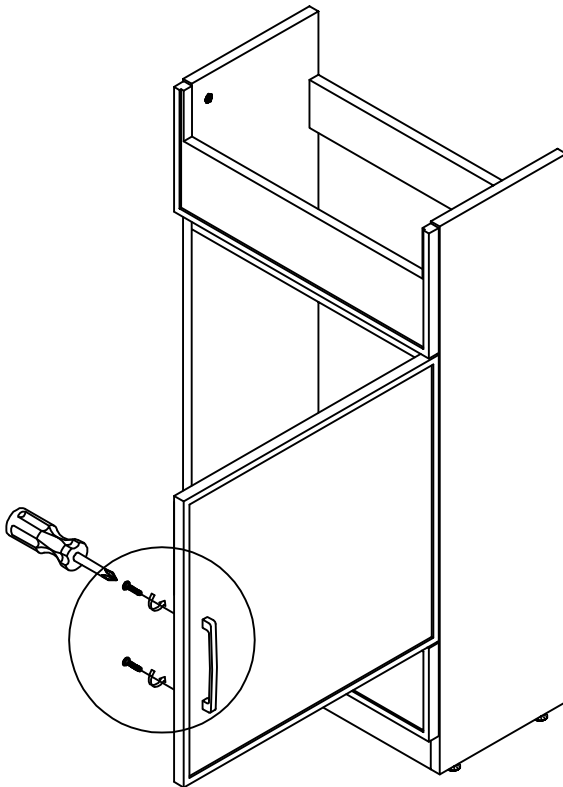

1. Install the door handle with 4*20handle screws.

| HARDWARE LIST | | |
|--|--|---|
| 4*20mm screw | Door handle |  |
| G  2PCS | H  1PCS | |



Choking hazard-Small Parts : This unit contains small parts, not for children under 3 years.

Tip-over hazard : Secure finished unit to wall stud using L-Bracket and wall screw (#10*1.5"W/out provided). If a wall stud is not neccessible , Consault your local hardware store for appropriate mounting hardware . Failure to properly install will result in product collapse or tip-over. Serious injury can occur .