

**USER MANUAL | MODE D'EMPLOI | MANUAL DEL USUARIO | MONTAGEANLEITUNG |
MONTAGEHANDLEIDUNG | MANUALE PER L'UTENTE | MANUAL DO UTILIZADOR**

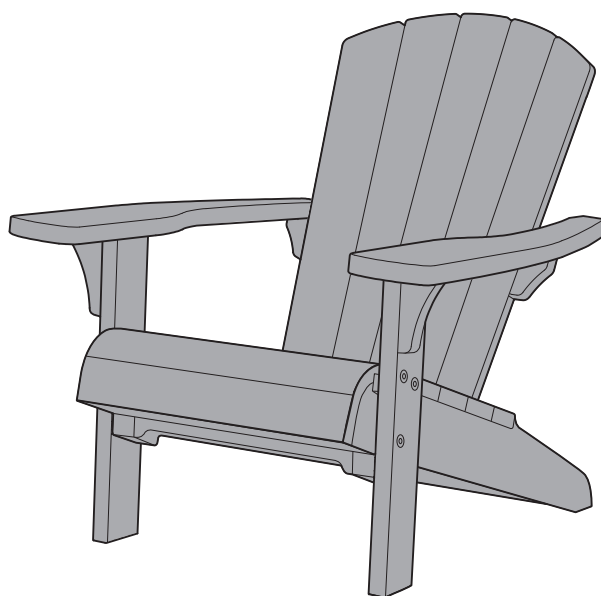

Digital manual | Manuel numérique | Manual
digital | Digitale Anleitung | Digitale handleiding |
Manuale digitale | Manual digital







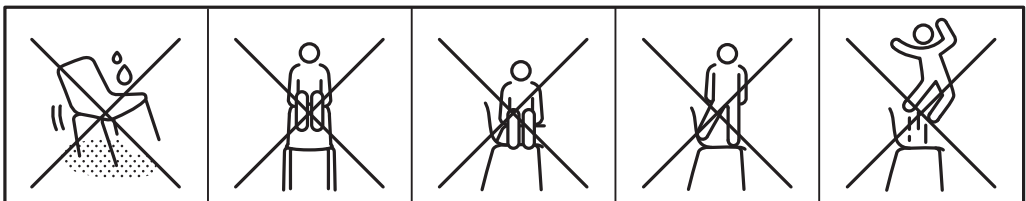
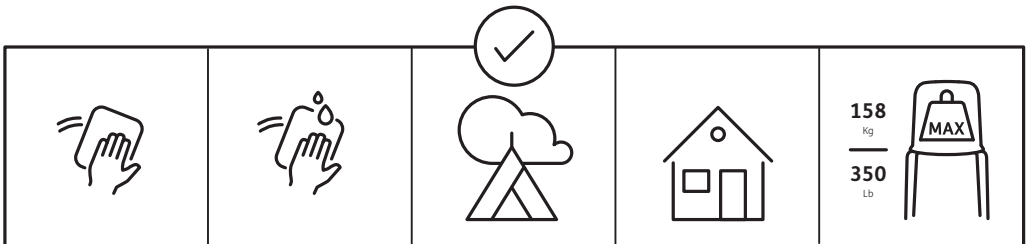

- **Attention - instructions to be kept for further reference.**
- **Position in a stable way on a flat ground.**
- **Spare parts not available beyond guarantee.**
- Important – a conserver pour une consultation ultérieure, à lire attentivement.
- Positionner de manière stable sur un sol plan.
- Pièces détachées non disponibles hors garantie.
- **Atención – guardar las instrucciones para futura referencia.**
- **Colocar en una posición estable sobre terreno llano.**
- **Piezas de repuesto no disponibles finalizada la garantía.**
- Achtung - anleitung soll als zukünftige referenz aufbewahrt werden.
- Stabil auf ebenem Boden aufstellen.
- Ersatzteile nach auslaufen der garantie nicht erhältlich.
- **Attenzione: le istruzioni devono essere conservate con cura per riferimenti futuri.**
- **Posizionare in maniera stabile o su un terreno piano.**
- **Pezzi di ricambio non disponibili superato il periodo di garanzia.**
- Let op – instructies moeten voor toekomstige raadpleging worden bewaard.
- Plaats op stabiele wijze op een vlakke ondergrond.
- Reserveonderdelen zijn niet verkrijgbaar na de garantieperiode.
- **Atenção - as instruções devem ser guardadas para referência futura.**
- **Posicionar numa forma estável num piso plano.**
- **As peças sobressalentes não estão disponíveis além da garantia.**

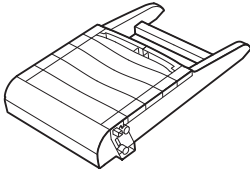
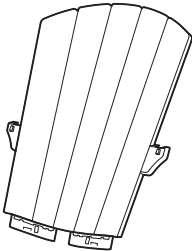
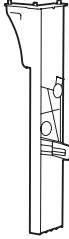
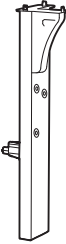

ASSEMBLY PARTS | PIÈCES À ASSEMBLER | PIEZAS DE ENSAMBLE | MONTAGETEILE | PARTI DA MONTARE | ONDERDELEN | PEÇAS DE MONTAGEM |

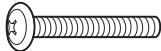
 <p>S (x1)</p>	 <p>B (x1)</p>	 <p>RL (x1)</p>	 <p>LL (x1)</p>
 <p>RS (x1)</p>	 <p>LS (x1)</p>	 <p>(x10)</p>	 <p>1/4 Inch (x10)</p>

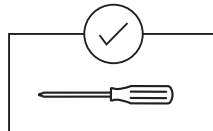

1



S (x1)



B (x1)

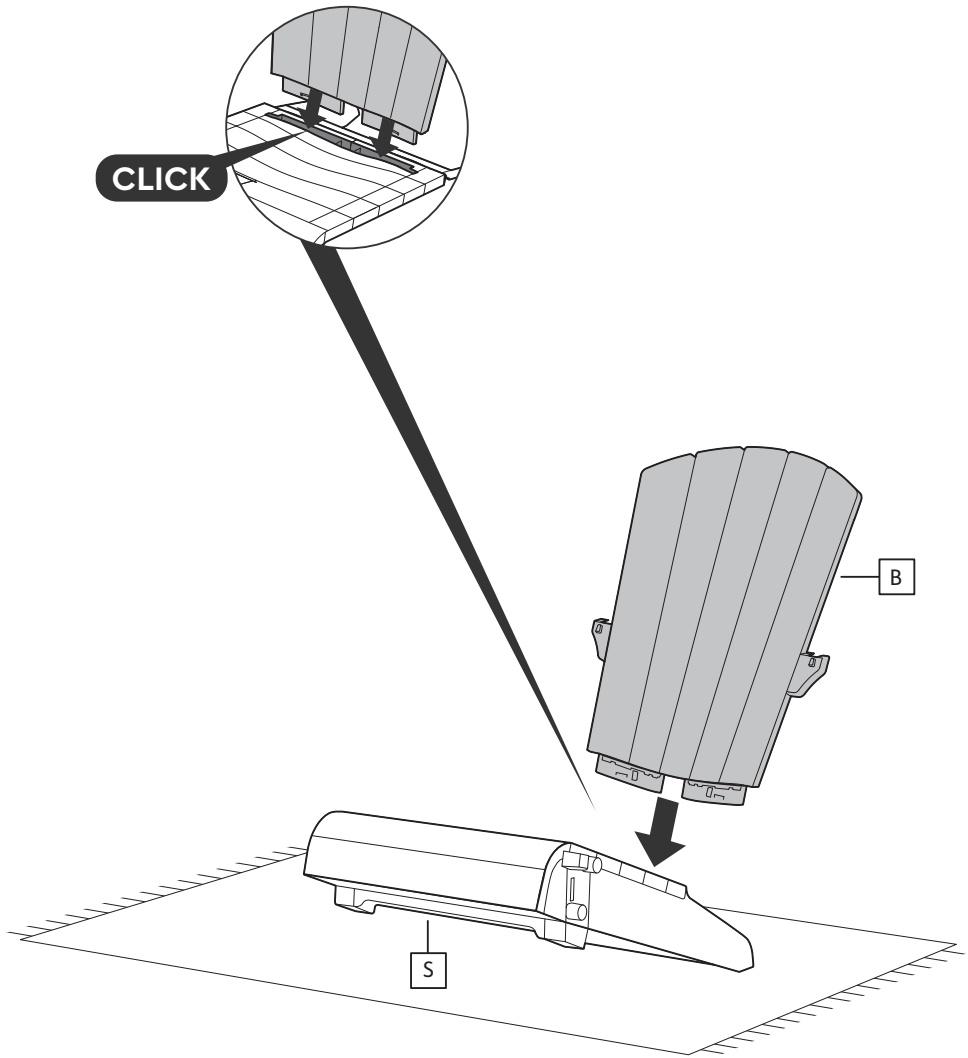

2

Ø (x3)

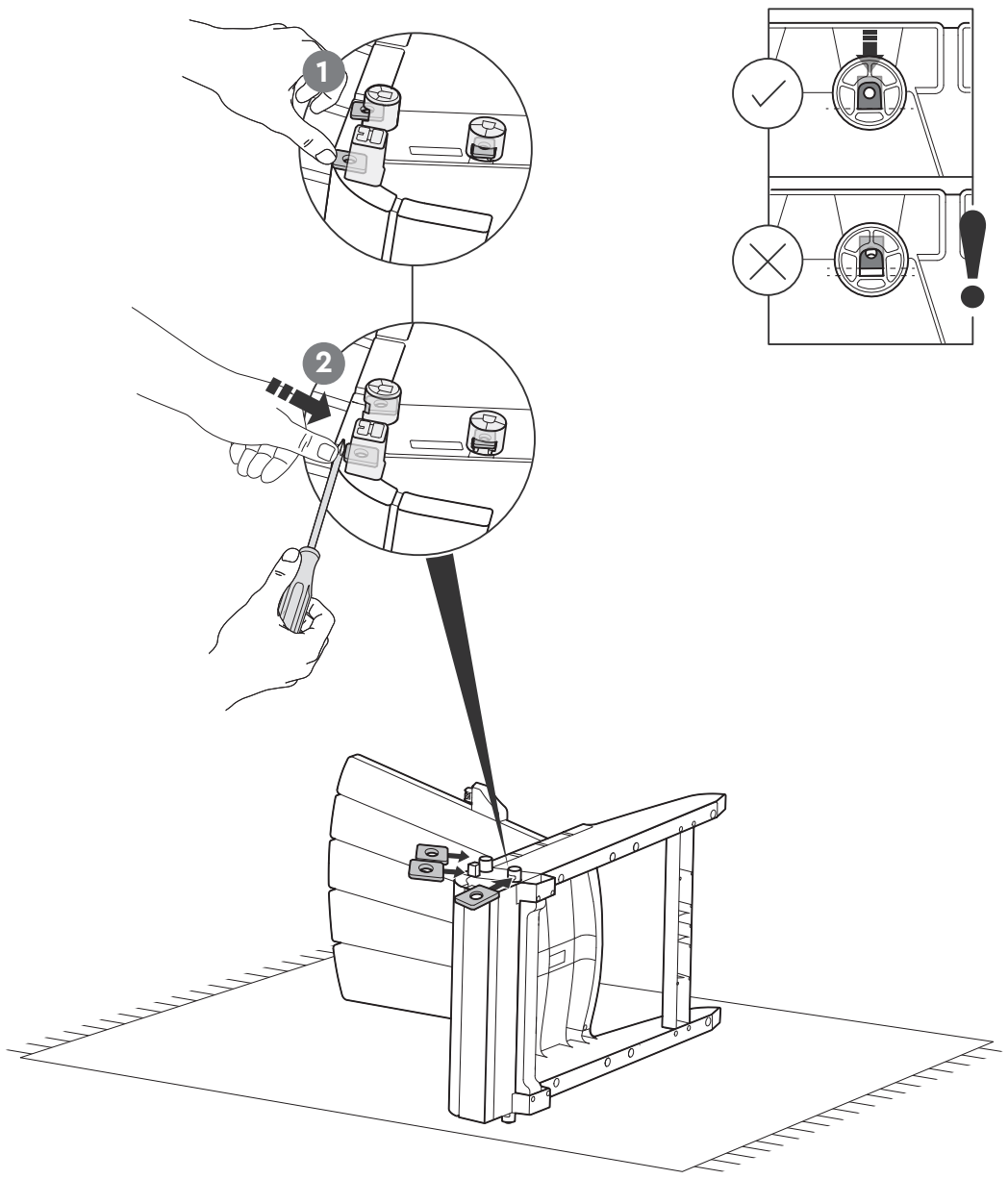
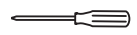

3



LL (x1)



1/4 Inch (x3)

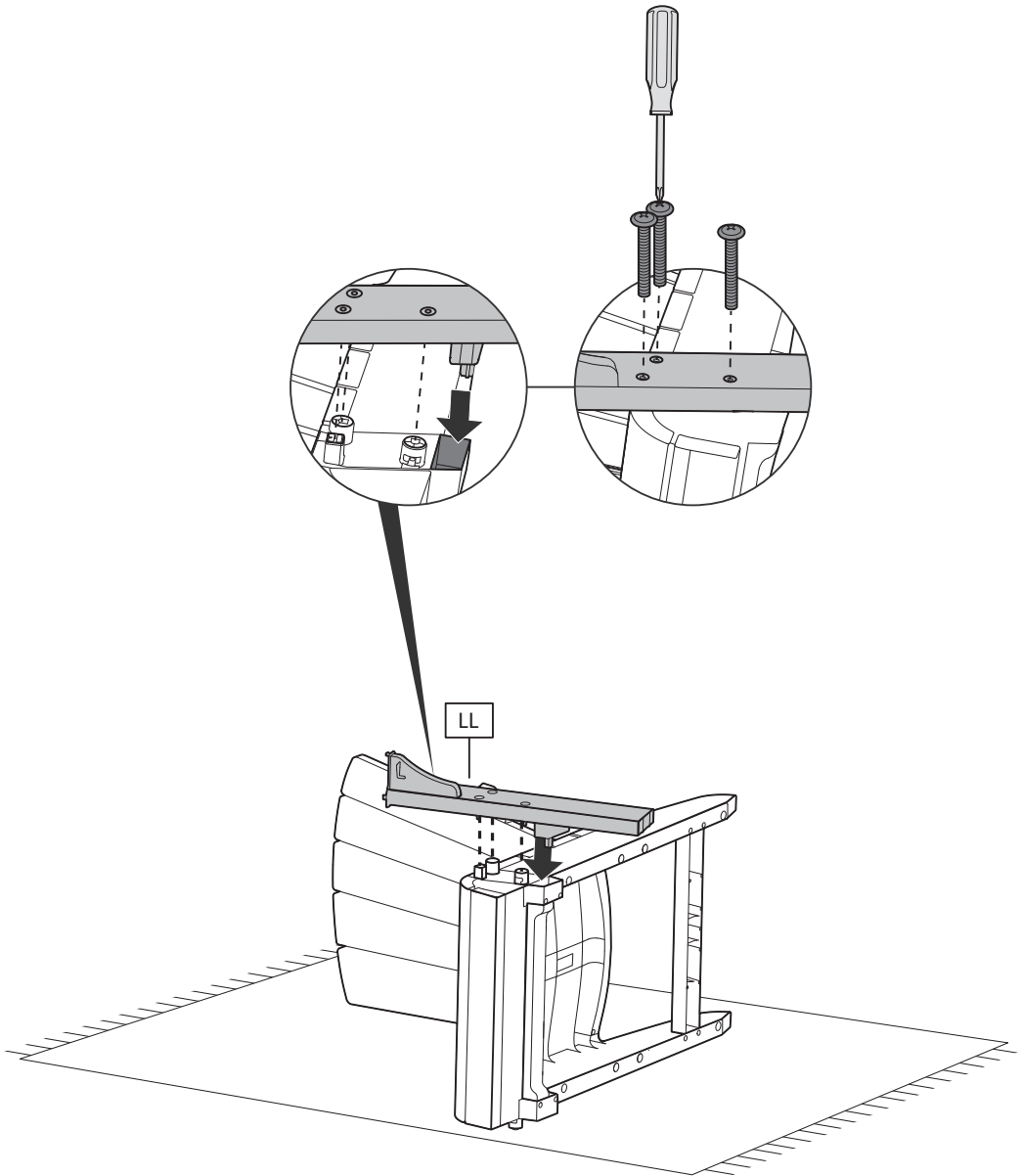

4

⌀ (x3)

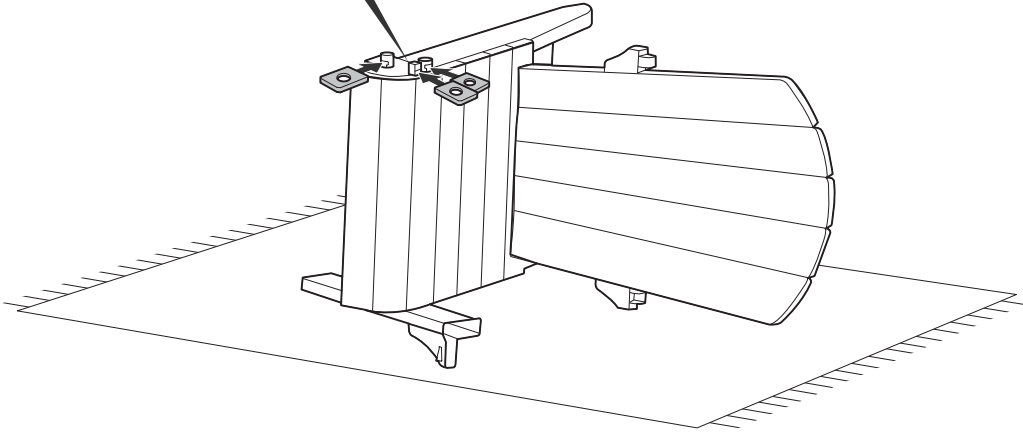
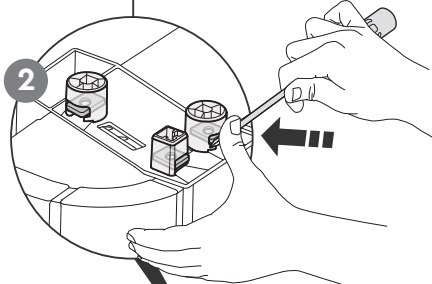
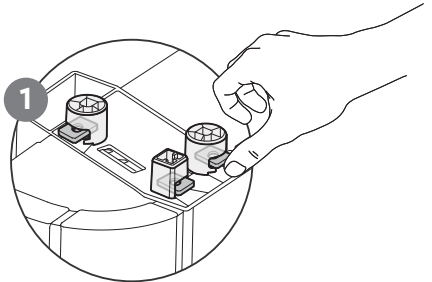
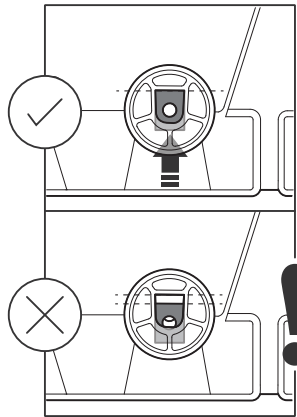
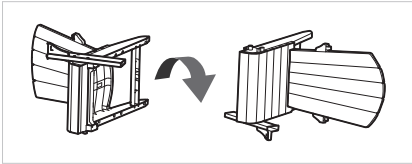
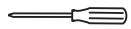

5



RL (x1)



1/4 Inch (x3)

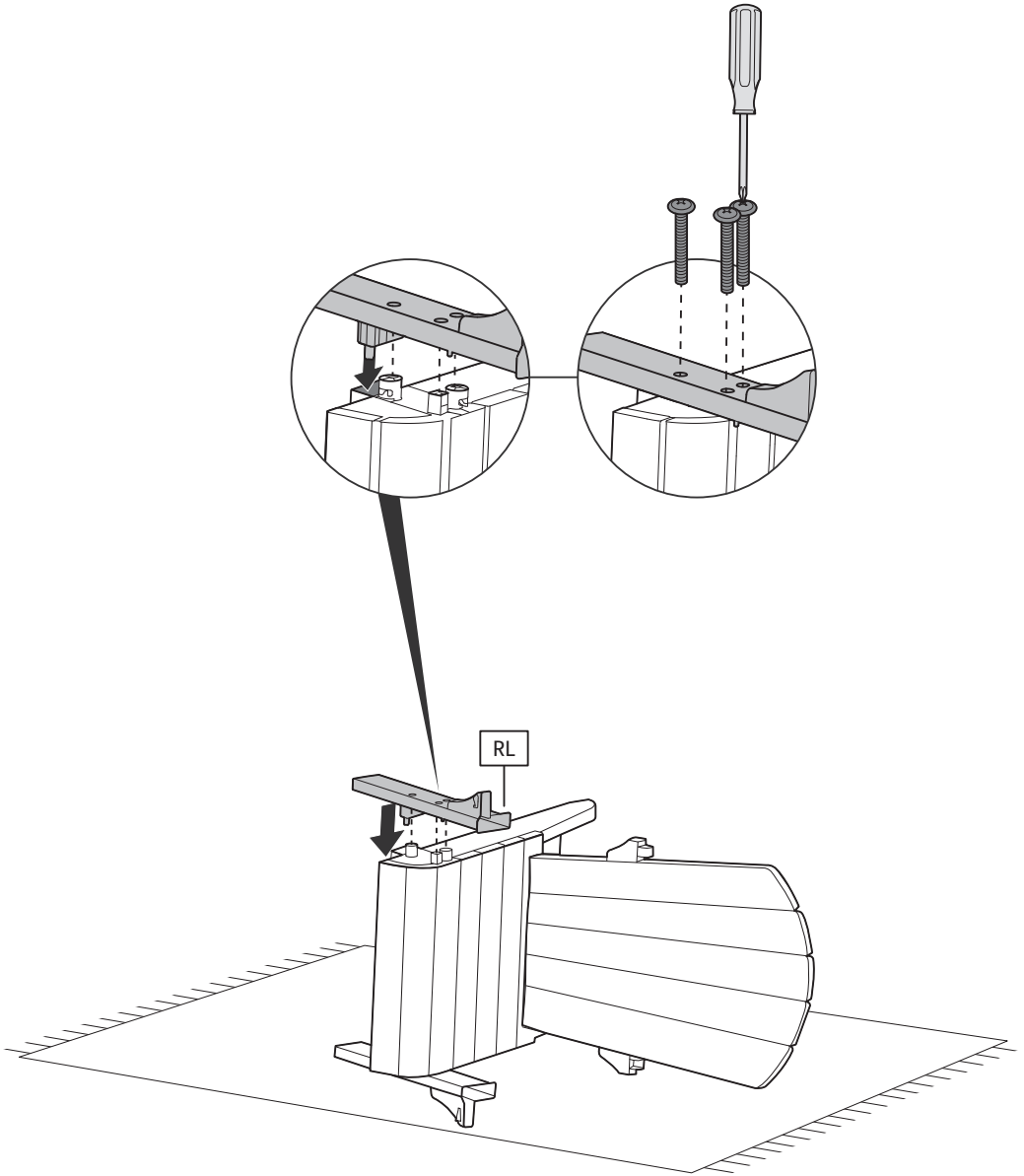
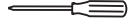

6



RS (x1)



LS (x1)



O (x4)

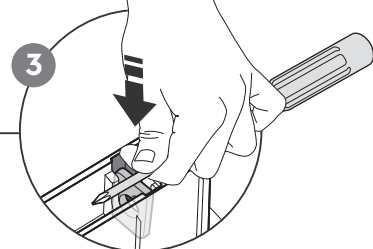
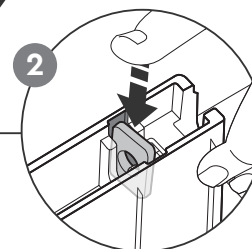
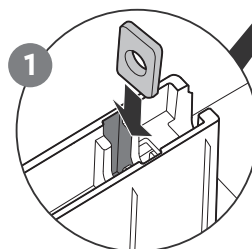
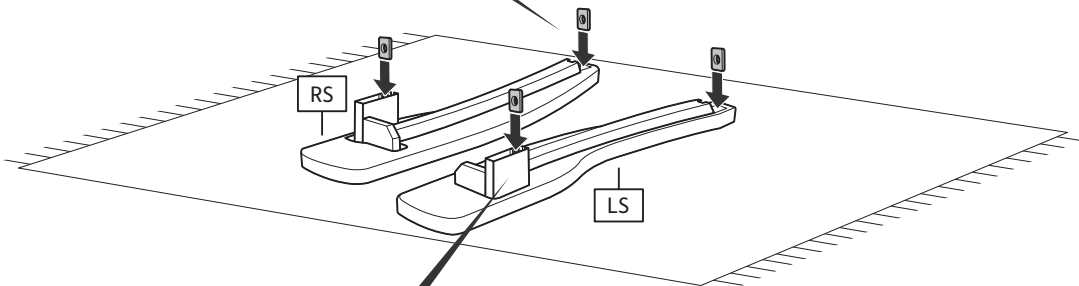
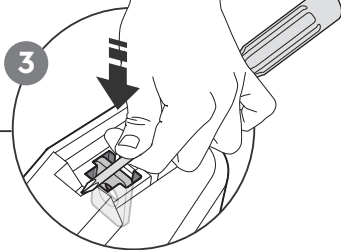
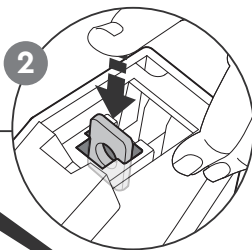
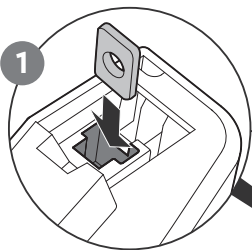
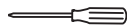

7

RS (x1)

LS (x1)

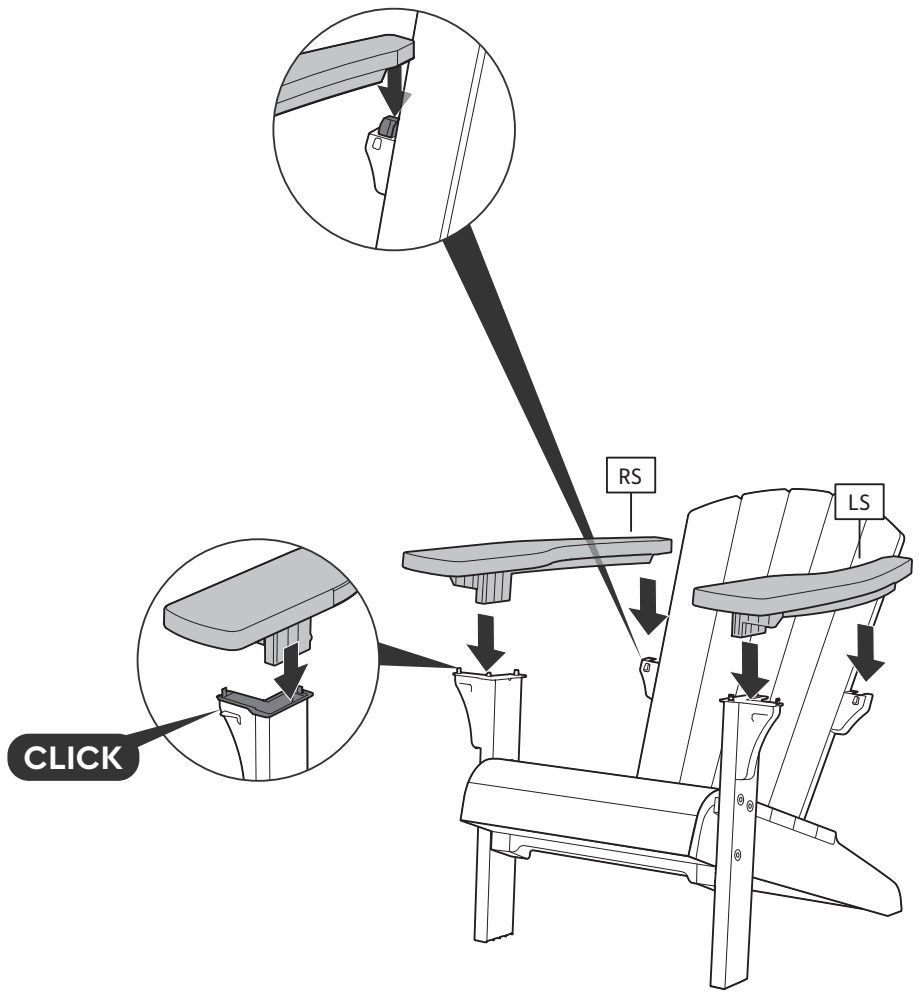

8

1/4 Inch (x4)

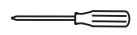



**IF THERE ARE MISSING OR BROKEN PARTS, PLEASE DO NOT RETURN THE PRODUCT TO THE STORE.
Please log onto our website, or contact Customer Service .**

S'IL Y A DES PIÈCES MANQUANTES OU CASSÉES, NE RETOURNEZ PAS LE PRODUIT AU MAGASIN.
Veuillez visiter notre site Internet, ou contacter notre Service Clientèle.

SI HUBIERA ALGUNA PARTE FALTANTE O DAÑADA, NO DEVUELVA EL PRODUCTO A LA TIENDA.
Inicie sesión en nuestro sitio en Internet o contáctese con nuestro servicio de atención al cliente.

BITTE BRINGEN SIE IHR PRODUKT NICHT GLEICH ZUM LADEN ZURÜCK, FALLS TEILE FEHLEN ODER DEFEKT SIND.
Bitte loggen Sie in unsere Website ein oder wenden Sie sich an unseren Kundenservice.

IN GEVAL VAN ONTBREKENDE OF GEBROKEN ONDERDELEN NIET HET PRODUCT NAAR DE WINKEL RETOURNEREN.
Ga naar onze website of neem contact op met de Klantenservice.

IN CASO DI PARTI MANCANTI O DANNEGGIATE, EVITARE DI RESTITUIRE IL PRODOTTO AL NEGOZIO.
Accedere al nostro sito o contattare il Servizio Clienti.

SE HOUVER PEÇAS EM FALTA OU PARTIDAS, NÃO DEVOLVA O PRODUTO À LOJA.
Entre na nossa página de Internet ou contacte o Serviço de Clientes.

Le développement durable au
quotidien | Sostenibilidad día a día



Designed to Last | Conçu pour durer | Diseñado
para durar | Auf Langlebigkeit ausgelegt |
Duurzaam ontworpen | Progettato per durare |
Projetado para durar



Community | Communauté |
Comunidad | Community |
Community | Comunità | Comunidade



Recyclability & Recycling | Recyclabilité et
Recyclage | Reciclabilidad y reciclable | recyclefähig
& recycelt | Recyclebaarheid & recycling |
Riciclabilità e Riciclo | Reciclabilidade e Reciclogem



Responsible Manufacturing | Fabrication responsable |
Producción responsable | Verantwortungsbewusste
Herstellung | Verantwoorde productie |
Produzione responsabile | Fabricação responsável