

## NOTICE

\*Please make sure that you have all parts indicated and they are in good condition before you begin assembly of this item. Refer to part list and hardware list below for guidance.

\*This item should be assembled on a soft surface to prevent scratching the finish during assembly.

\*This item may require periodic tightening.

\*If you are having difficulty, our friendly Customer Care team is always here to help.

## PREPARATION

\*Before beginning assembly of product, make sure all parts are present. Compare parts with part contents list and hardware contents list.

\*If any part is missing or damaged, do not attempt to assemble the product.

\*Estimated Assembly Time: 60 minutes.

\*Tools Required for Assembly (included): Allen Key

## CARE AND MAINTENANCE

Always use felt pads under all articles to prevent discoloration or softening of the lacquer. Plastic and rubber bases on items can discolor wood. Wipe up spills immediately and avoid common hazards such as hot dishes, harsh solvents and abrasives. Cleaning should be done with a soft lint free cotton cloth dampened with water or furniture polish. On highly used surfaces we recommend applying a quality paste wax which should be used on a regular basis to provide additional protection from scratches and spills. How often you apply the wax depends on how much wear the furniture receives.

### Part List

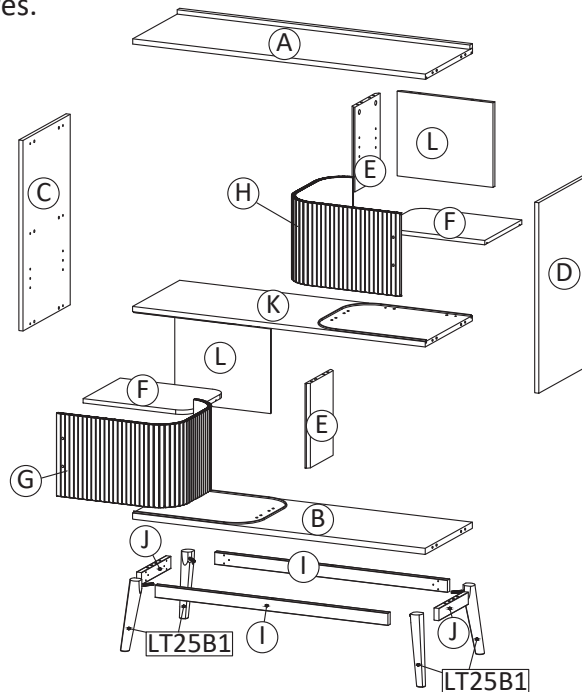

**Product Dimensions: 43"Wx15"Dx35"H**

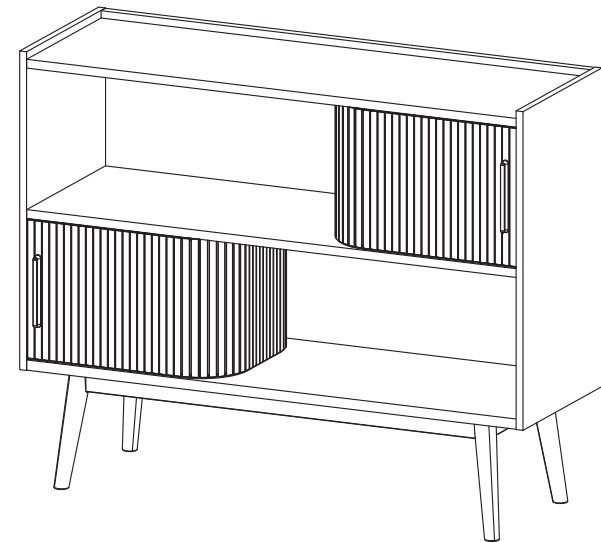











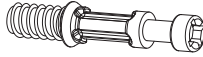

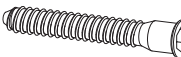

**WARNING :**

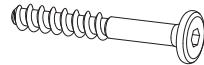
**WEIGHT CAPACITY: 53 LBS.**

**Warning : Do not stand on media stand.**

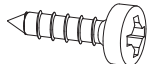
**Warning : Do not over torque bolts.**

## Hardware List

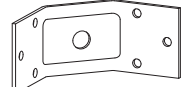
<p>HW1x24</p>  <p>∅ 6 x 35 mm</p>	<p>HW2x16</p>  <p>∅ 15 mm</p>	<p>HW3x8</p>  <p>∅ 12 mm</p>	<p>HW4x28</p>  <p>∅ 8 x 30 mm</p>	<p>HW5x8</p>  <p>∅ 6 x 30 mm</p>
<p>HW6x4</p>  <p>M 7 x 50 mm</p>	<p>HW7x2</p>  <p>L 4</p>	<p>HW8x10</p>  <p>M 6.4 x 53 mm</p>	<p>HW9x8</p> 	<p>HW10x4</p>  <p>∅ 15 mm</p>
<p>HW11x1</p> 	<p>HW12x2</p> 	<p>HW13x24</p>  <p>M 4 x 16 mm</p>	<p>HW14x4</p>  <p>M 4 x 18 mm</p>	<p>HW15x4</p> 
<p>HW16x4</p> 	<p>HW BC410x4</p> 			

### Part List & HW For Multi-Box Items

Piece	Description	Qty
A	Top Board	1
B	Bottom Board	1
C	Side Board Left	1
D	Side Board Right	1
E	Center Board	2
F	Adjustable Shelf	2
G	Door 1	1
H	Door 2	1
I	Bottom Skirt 1	2
J	Bottom Skirt 2	2
K	Fixed Shelf	1
L	Back Board	2
LT25B1	Leg	4

Piece	Description	Qty
HW1	Cambolt	24
HW2	CamLock Big	16
HW3	CamLock Small	8
HW4	Dowel Big	28
HW5	Dowel Small	8
HW6	Screw M 7 x 50 mm	4
HW7	Allen Key	2
HW8	Screw M 6.4 x 53 mm	10
HW9	Shelf Pin	8
HW10	Screw Cap	4
HW11	Wrench	1
HW12	Handle	2
HW13	Screw M 4 x 16 mm	24
HW14	Screw M 4 x 18 mm	4
HW15	Ring	4
HW16	Flange Nut	4
HW BC410	Corner Brace	4

# PREPARATION

- \*Before beginning assembly of product, make sure all parts are present. Compare parts with part contents list and hardware contents list.
- \*If any part is missing or damaged, do not attempt to assemble the product.
- \*Estimated Assembly Time: 60 minutes.
- \*Tools Required for Assembly (included): Allen Key
- \*If you are having difficulty, our friendly Customer Care team is always here to help.

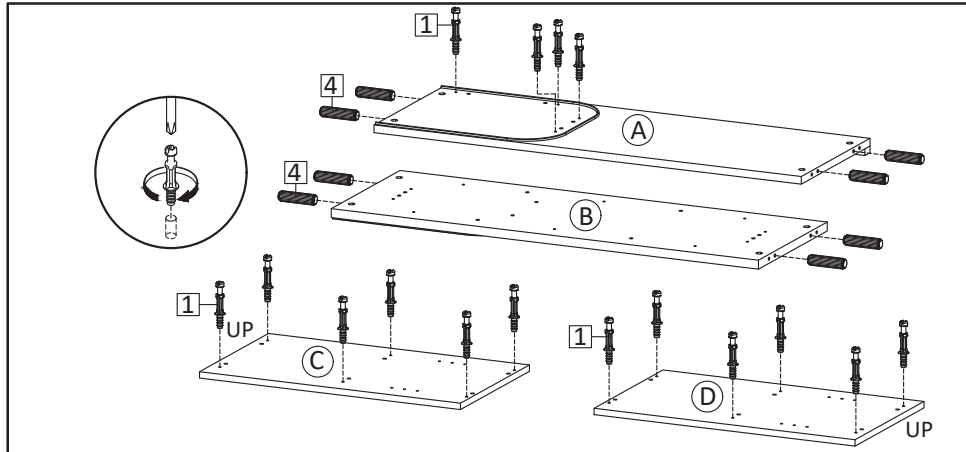

**STEP1:** Insert Cambolt (HW1) into Top Board (A) and Side Boards (C&D). Insert Dowel Big (HW4) into Bottom Board (B) and Top Board (A).

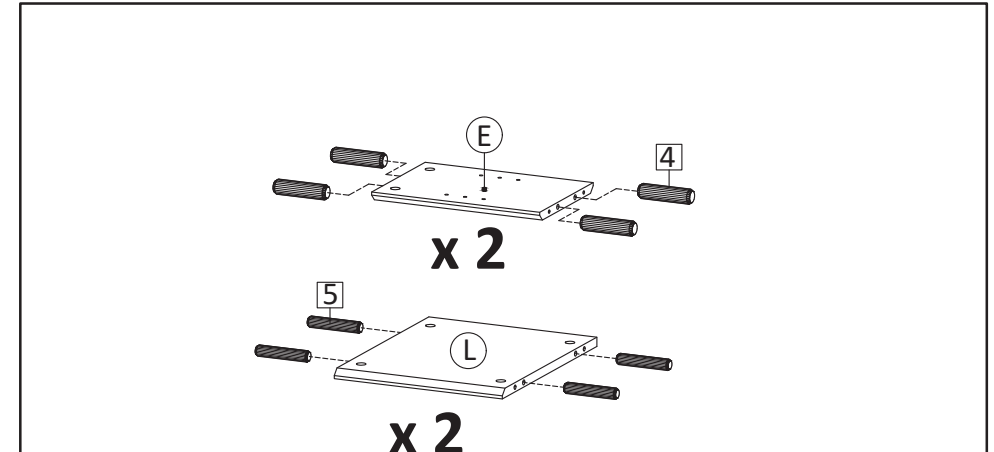

**STEP2:** Insert Dowel Big (HW4) into Center Boards (E) and insert Dowel small (HW5) into Back Board (L).

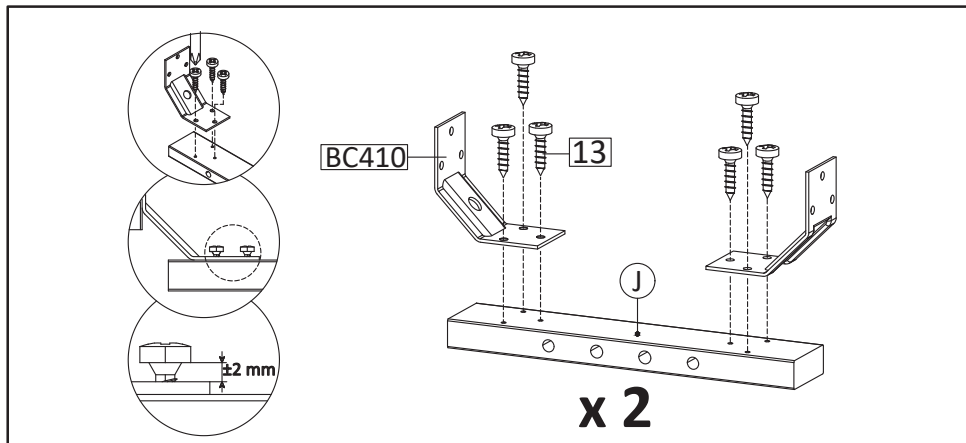

**STEP3:** Now let's combine the bottom skirt. Start with installing Corner Brace (HW BC410) into Bottom Skirt 2 (J) using Screw M4x16mm (HW13). Do not overtight screw yet, leave around 2mm gap.

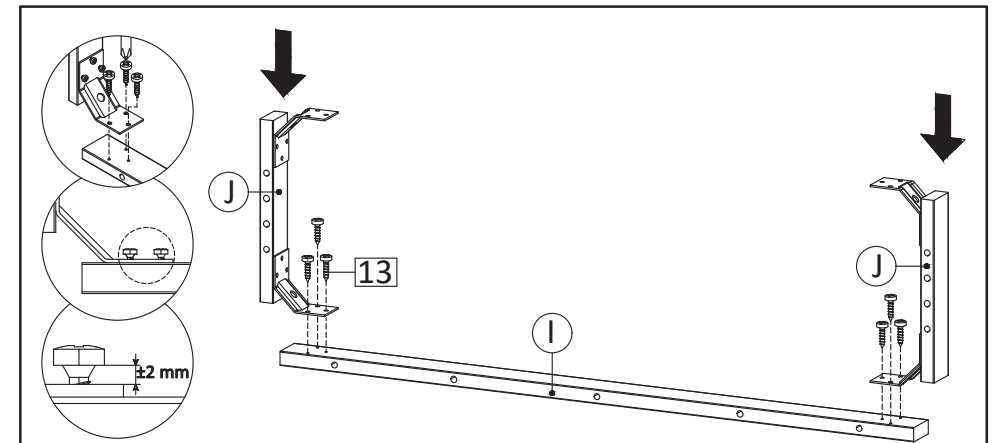

**STEP4:** Combine the Bottom Skirt 2 from step 3 with Bottom skirt 1 (I), using Screw M4x16mm (HW13). Do not overtight screw yet, leave around 2mm gap.

# PREPARATION

- \*Before beginning assembly of product, make sure all parts are present. Compare parts with part contents list and hardware contents list.
- \*If any part is missing or damaged, do not attempt to assemble the product.
- \*Estimated Assembly Time: 60 minutes.
- \*Tools Required for Assembly (included): Allen Key
- \*If you are having difficulty, our friendly Customer Care team is always here to help.

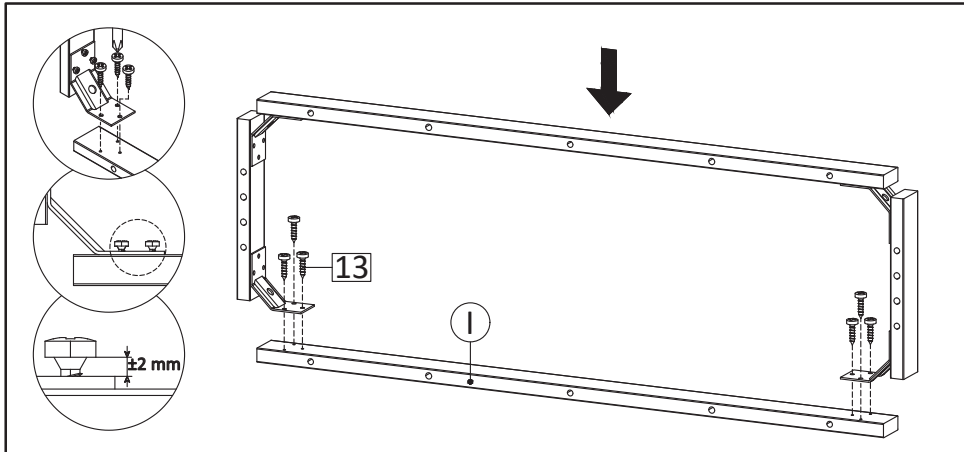

**STEP5:** Combine components from step 4 with remaining Bottom skirt 1 (I), using Screw M4x16mm (HW13). Do not overtight screw yet, leave around 2mm gap.

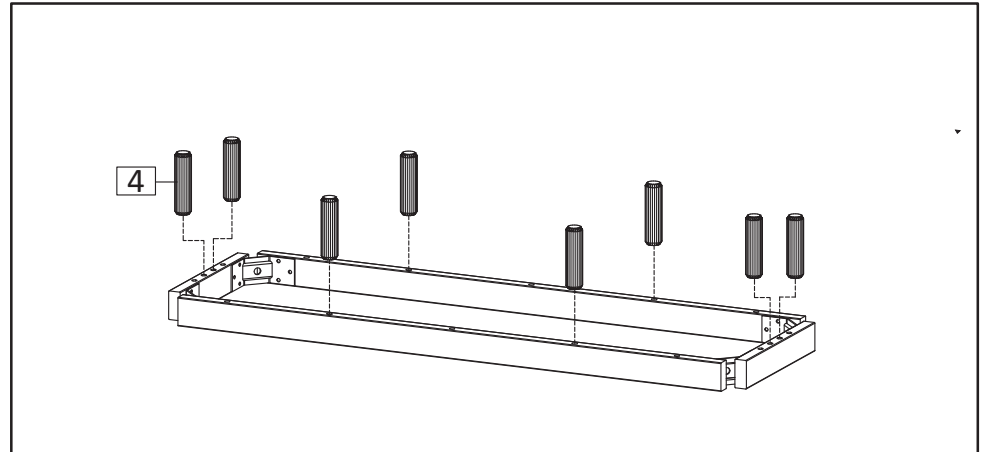

**STEP6:** Insert Dowel Big (HW4) into assembled Bottom skirt from previous step.

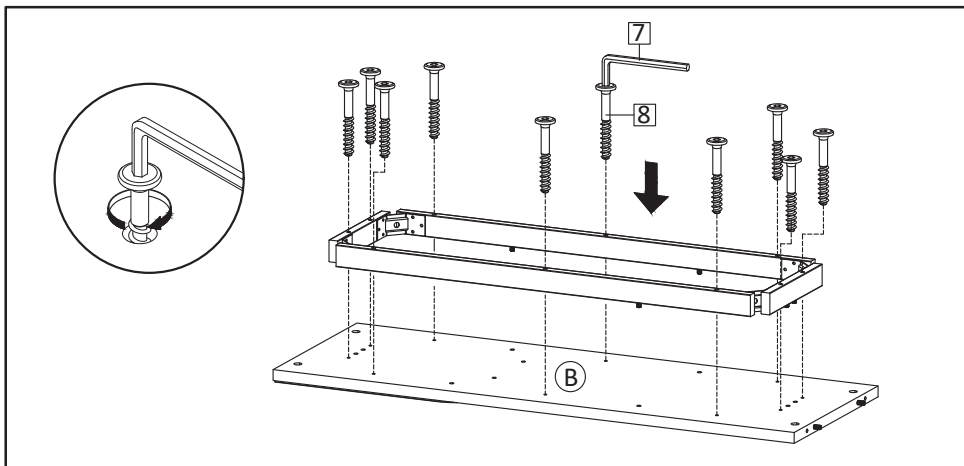

**STEP7:** Insert Screw M6.4x53mm (HW8) using Allen Key (HW7) into assembled bottom skirt and bottom board.

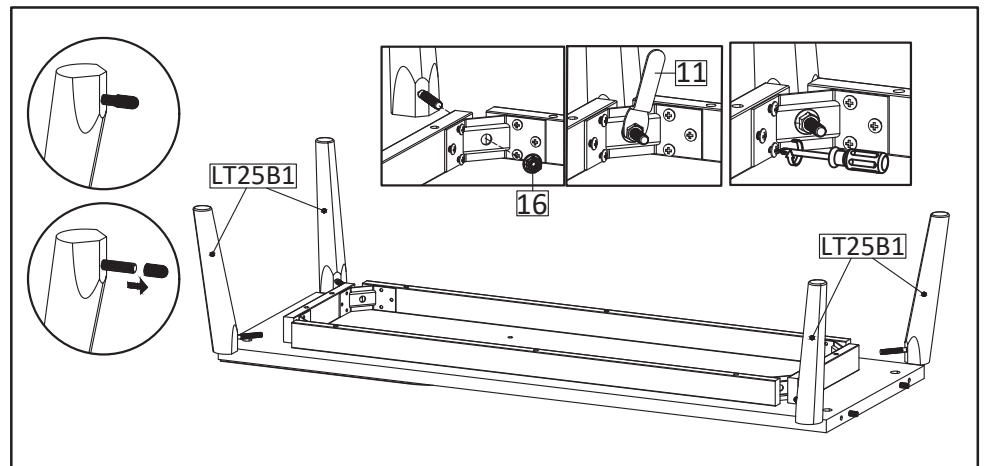

**STEP8:** First, let's fixing the leg by inserting leg to Corner Brace, Insert Flange Nut (HW16) first into the hanger bolt of leg, tighten all the Flange nut using provided Wrench (HW11). Second, after Ensuring that all legs has been tightened, continue with tighten all screws on the corner brace.

# PREPARATION

\*Before beginning assembly of product, make sure all parts are present. Compare parts with part contents list and hardware contents list.

\*If any part is missing or damaged, do not attempt to assemble the product.

\*Estimated Assembly Time: 60 minutes.

\*Tools Required for Assembly (included): Allen Key

\*If you are having difficulty, our friendly Customer Care team is always here to help.

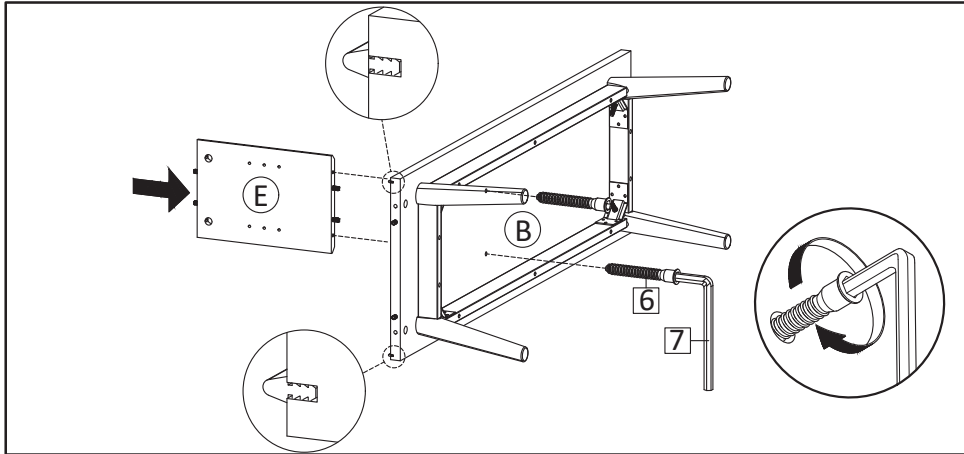

**STEP9:** Continue by attaching Center Board 1 (E) into the assembled components from step 8. secure with Screw M7x50mm (HW6) using Allen Key (HW7).

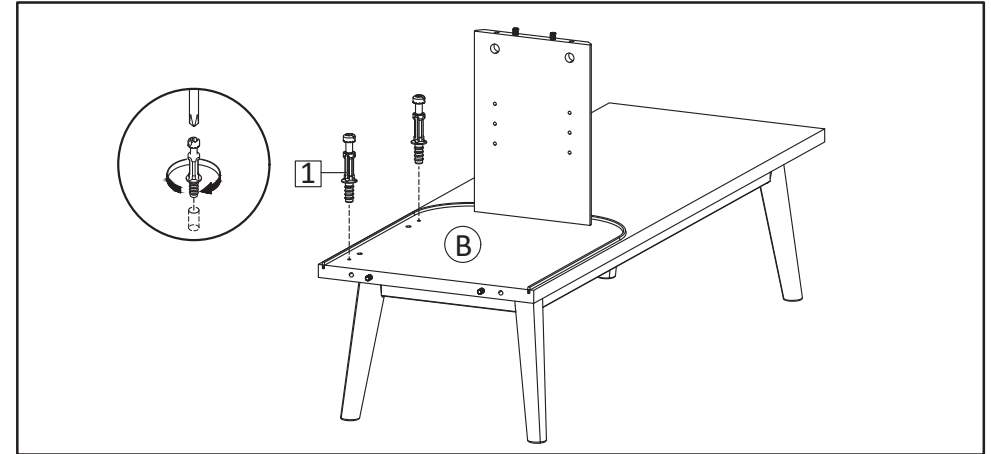

**STEP10:** Insert Cambolt (HW1) into Bottom Board (B) position as shown in the figure.

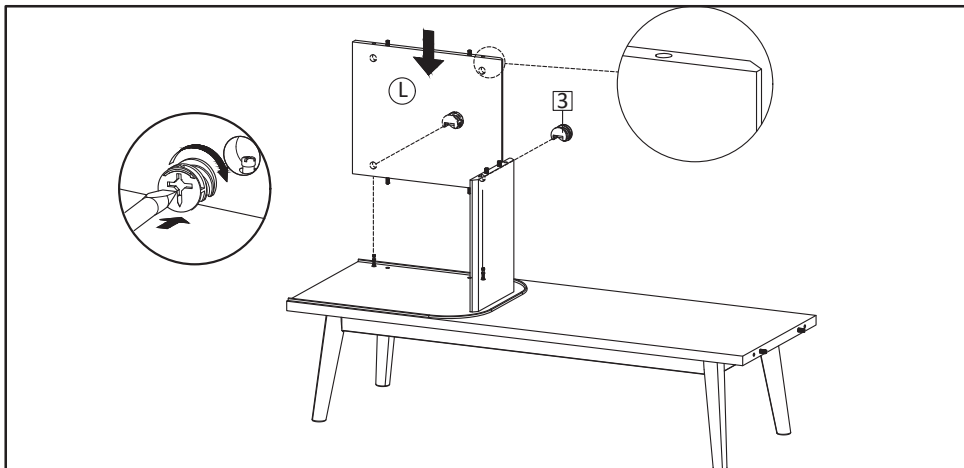

**STEP11:** Attach Back Board (L) into the assembled components from step 10. Secure with Camlock Small (HW3) and tighten it using screwdriver.

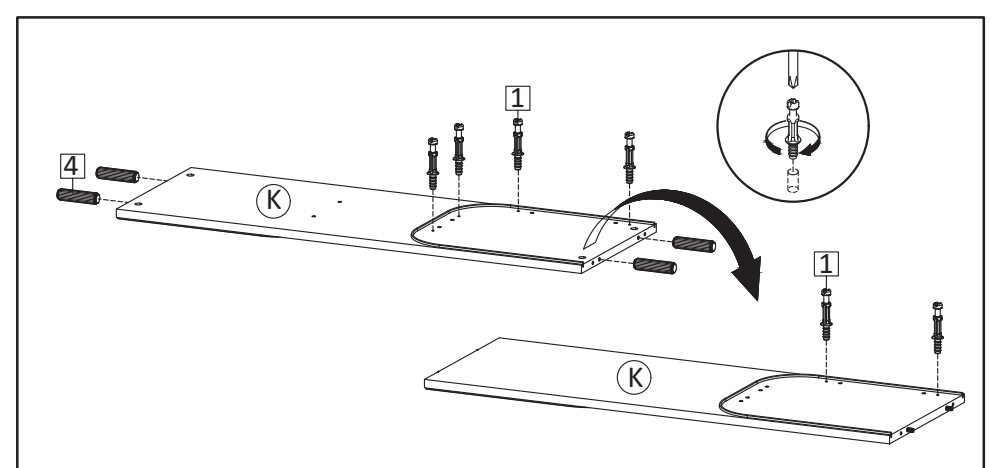

**STEP12:** Insert Cambolt (HW1) into Fixed Shelf (K) insert Dowel Big (HW4) then flip the board to access the opposite surface. Then insert Cambolt (HW1) as shown in the figure.

# PREPARATION

\*Before beginning assembly of product, make sure all parts are present. Compare parts with part contents list and hardware contents list.

\*If any part is missing or damaged, do not attempt to assemble the product.

\*Estimated Assembly Time: 60 minutes.

\*Tools Required for Assembly (included): Allen Key

\*If you are having difficulty, our friendly Customer Care team is always here to help.

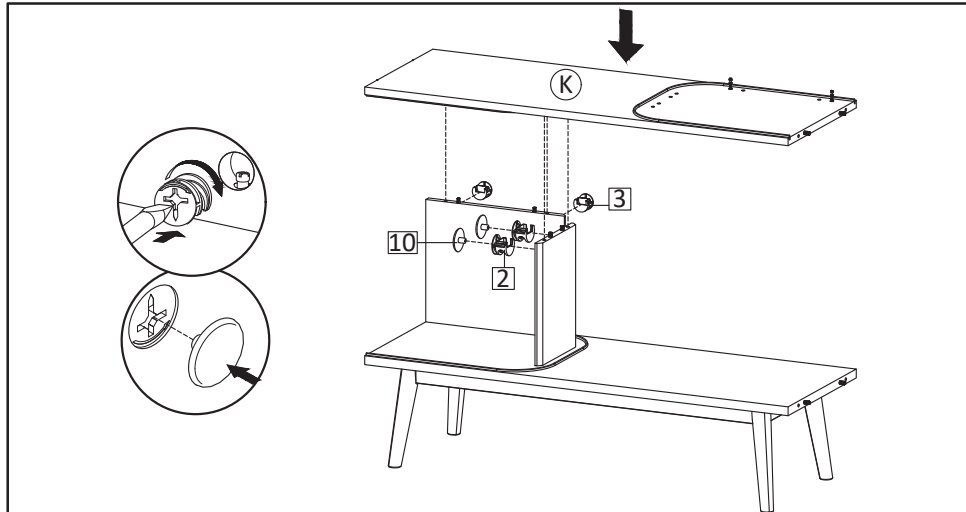

**STEP13:** Bring the Fixed Shelf (K), into assembled component. Secure with Camlock Big (HW2), Camlock Small (HW3) and tighten it using screwdriver. Put the Screw Cap (HW10) over the tightened camlock.

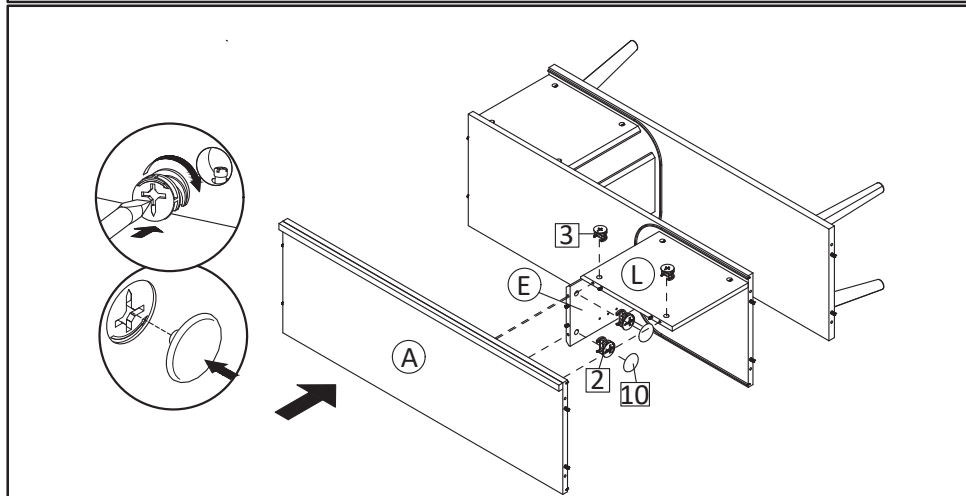

**STEP15:** Attach the Top Board (A), into assembled component. Secure with Camlock Big (HW2), Camlock Small (HW3) and tighten it using screwdriver. Put the Screw Cap (HW10) over the tightened camlock.

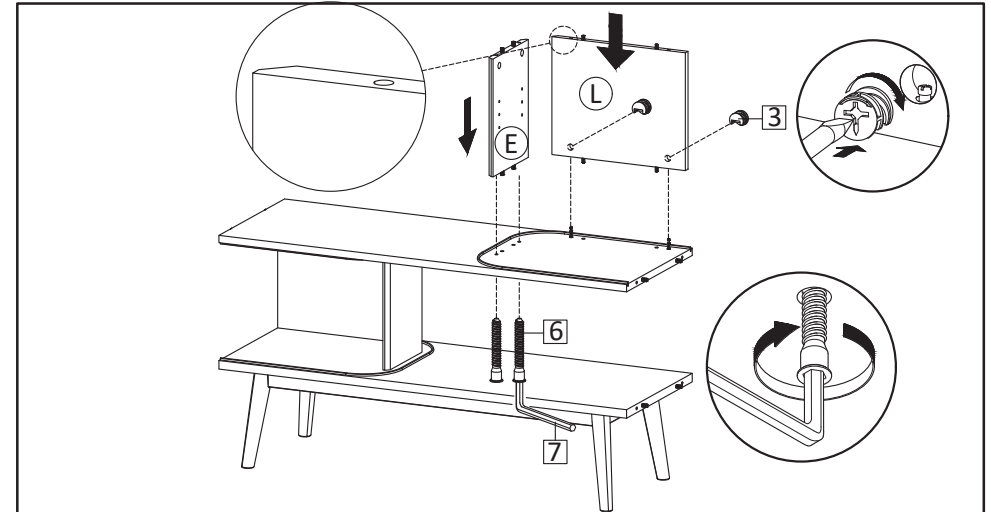

**STEP14:** Attach Back Board (L) and Center Board (E). Secure with Camlock Small (HW3) and tighten it using screwdriver. secure with Screw M7x50mm (HW6) using Allen Key (HW7). Do not force the fixed shelf (K) downward while doing this step.

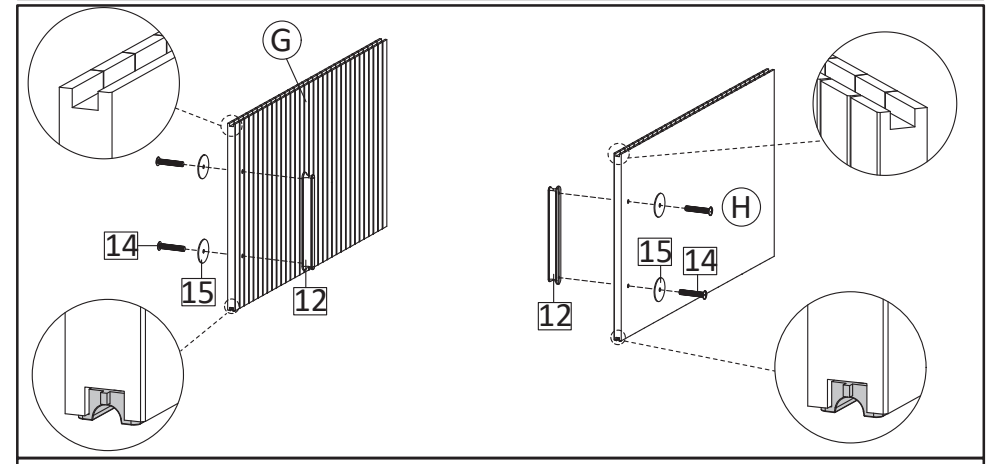

**STEP16:** Insert Handle (HW12) secure with Screw M4x18mm (HW14) and Ring (HW15) into the holes on Doors (G&H) position as shown in the figure.

# PREPARATION

- \*Before beginning assembly of product, make sure all parts are present. Compare parts with part contents list and hardware contents list.
- \*If any part is missing or damaged, do not attempt to assemble the product.
- \*Estimated Assembly Time: 60 minutes.
- \*Tools Required for Assembly (included): Allen Key
- \*If you are having difficulty, our friendly Customer Care team is always here to help.

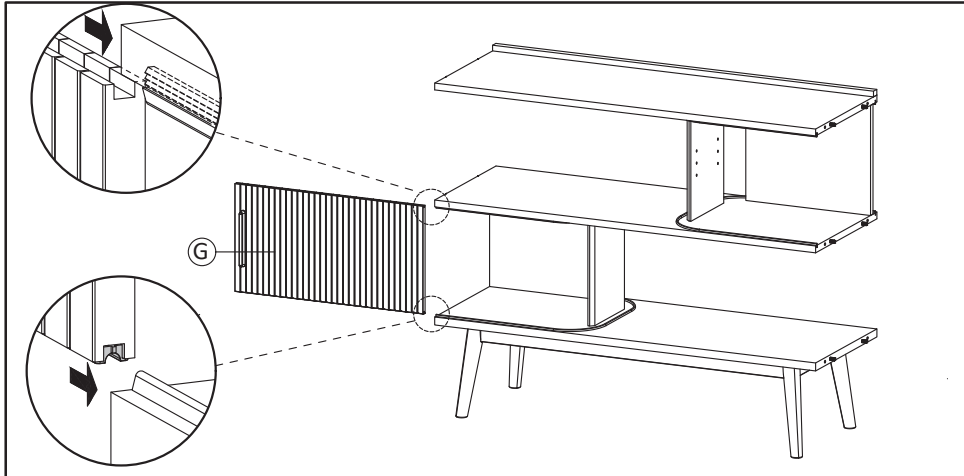

**Step17:** Insert the Door 1 (G) into the groove. Position the top and bottom parts of the door with the grooves of the top and bottom of the body. Follow the downward and upward directions position as shown in the figure. The groove on the door which has plastic insert is placed at bottom of the track.

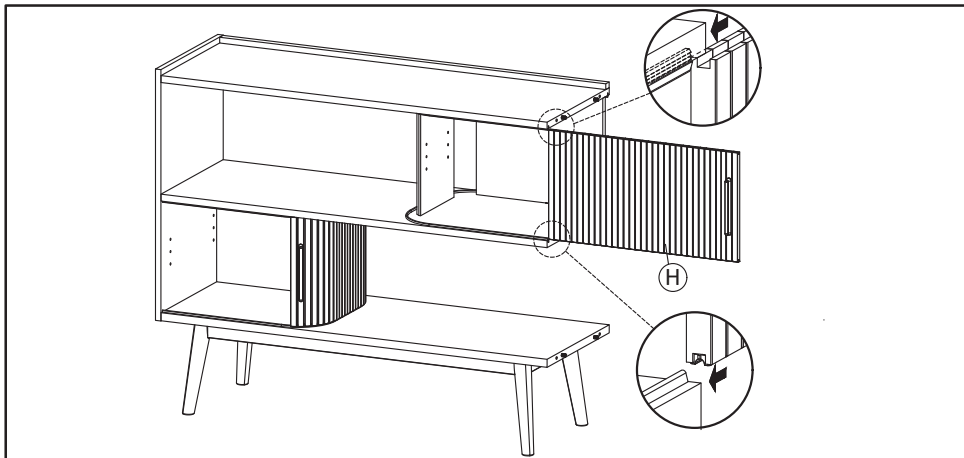

**Step19:** Insert the Door 2 (H) into the groove. Position the top and bottom parts of the door with the grooves of the top and bottom of the body. Follow the downward and upward directions position as shown in the figure. The groove on the door which has plastic insert is placed at bottom of the track.

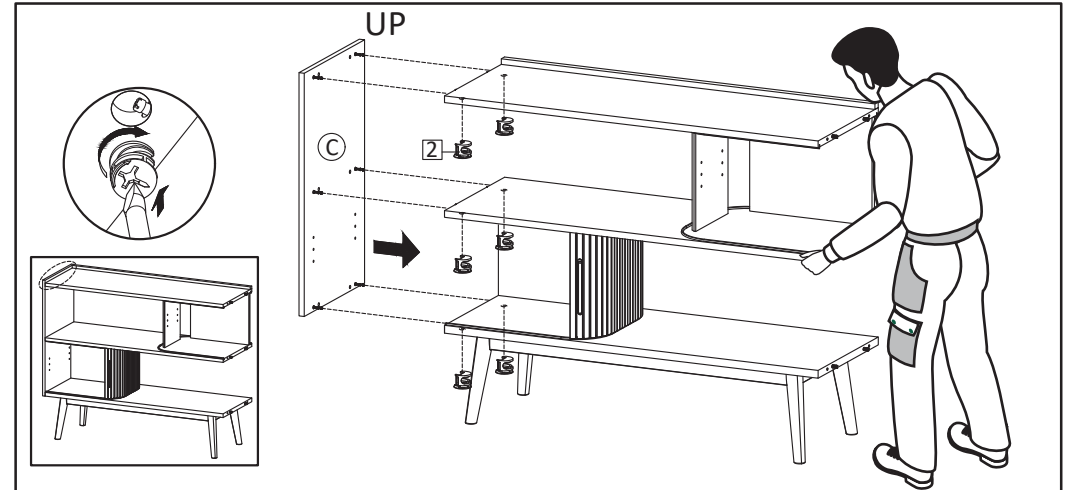

**STEP18:** Attach the Side Board Left (C), into assembled component. Secure with Camlock Big (HW2) and tighten it using screwdriver. Position as shown in the figure.

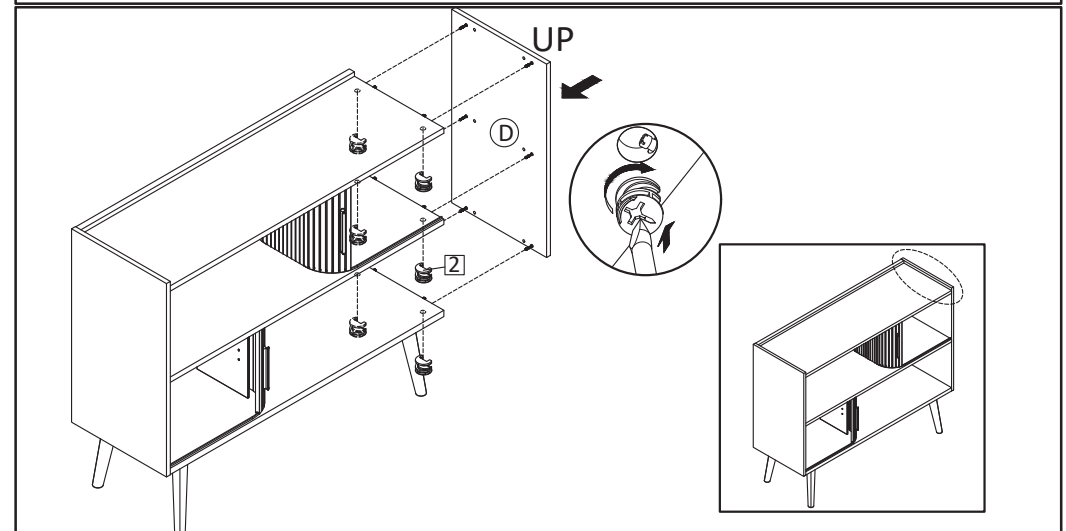

**STEP20:** Attach the Side Board Right (D), into assembled component. Secure with Camlock Big (HW2) and tighten it using screwdriver. Position as shown in the figure.

## PREPARATION

- \*Before beginning assembly of product, make sure all parts are present. Compare parts with part contents list and hardware contents list.
- \*If any part is missing or damaged, do not attempt to assemble the product.
- \*Estimated Assembly Time: 60 minutes.
- \*Tools Required for Assembly (included): Allen Key
- \*If you are having difficulty, our friendly Customer Care team is always here to help.

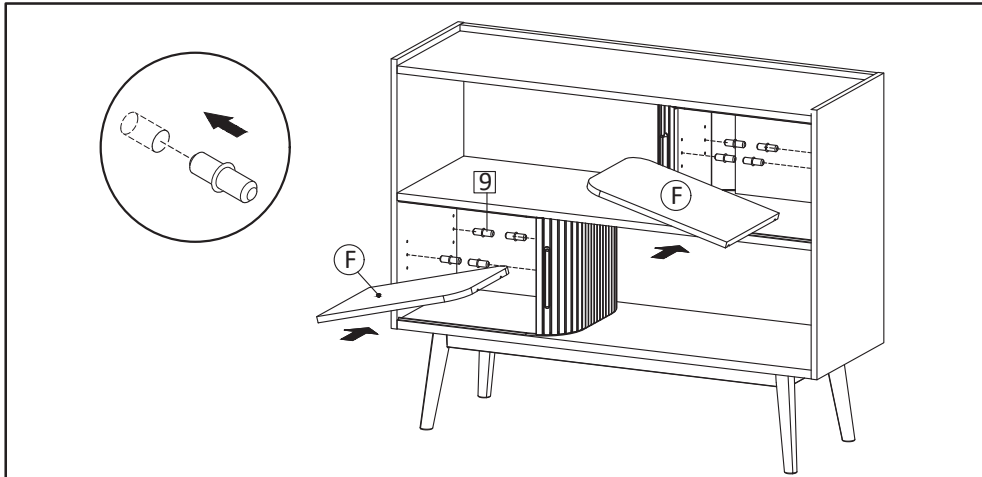

**STEP21:** Insert Shelf Pin (HW9) into the holes on Side board & Center board, on the desired level. Then place the Adjustable Shelf (F) by inserting the hole on the shelf into the shelf support.

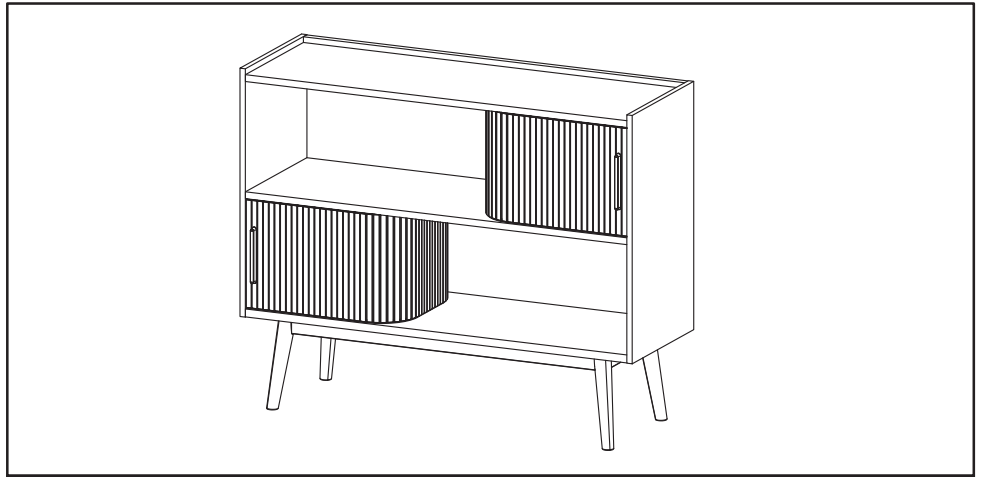

**STEP22:** Assembly is complete.

# TIPPING RESTRAINTS KIT INSTALLATION GUIDANCE

Different wall materials require unique wall fasteners.

The wall plugs (AA2) and screws (AA3) are designed for fixing to concrete walls only.

Please consult your local hardware store to ensure you are using the correct hardware for your wall type.

