

INSTALLATION







Assembly Instructions

The recliner comes packaged in one box. Carefully remove all of components from the packaging and set aside for assembly.

CAUTION:
DO NOT use any sharp objects to open plastic wrapped components as damage to product or components may result.

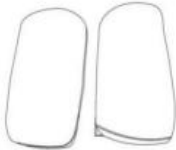
Package Contents

				
A 1* Chair Seat	B 1* Chair Back	C 2* Chair Arms	D 1* Remote	E 1* Plug

Installation Instruction

STEP 1: Put out all the parts from master carton and check the parts are complete and undamaged according to the above fitting list. **Please noted that** one chair arm(C) was placed in the back of chair seat (A) and another one was placed in the bottom of the chair seat (A). Please kindly refer to below picture.

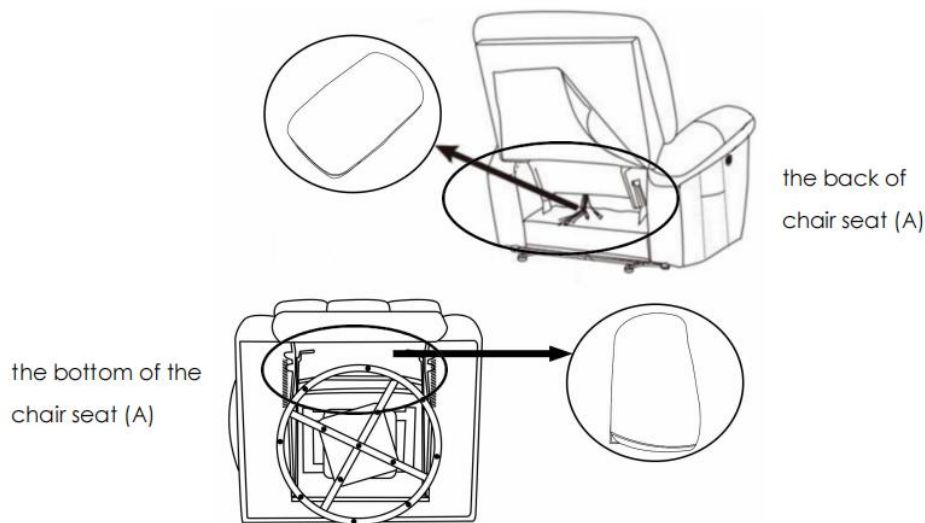

STEP 2: Assemble the Chair Arms (C) on the Chair Seat (A); The armrest has a zipper and velcro, which needs to be connected with the cushion.

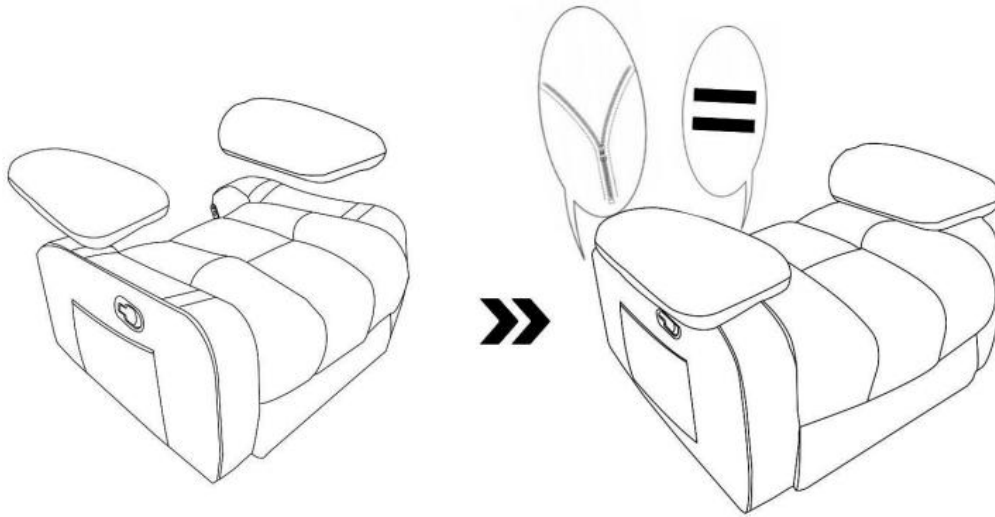

STEP 3: Attach Chair Back (B) to Chair Seat (A) by aligning the metal grooves on backrest to brackets on the main frame as shown. Ensure the Chair Back (B) slides down fully over the brackets on the Chair Seat(A).

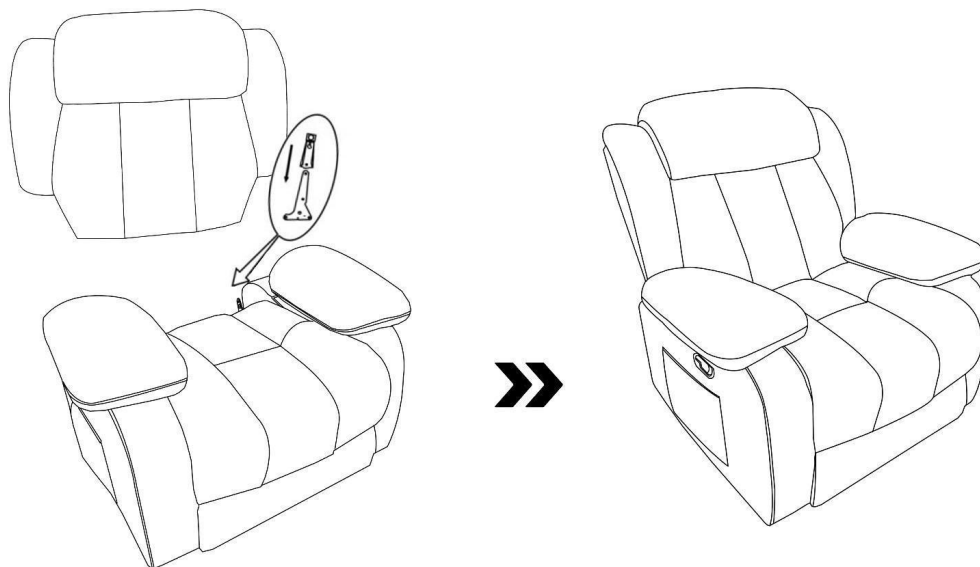

STEP 4: Connect the 4 power connection plugs as shown behind the seat correspondingly

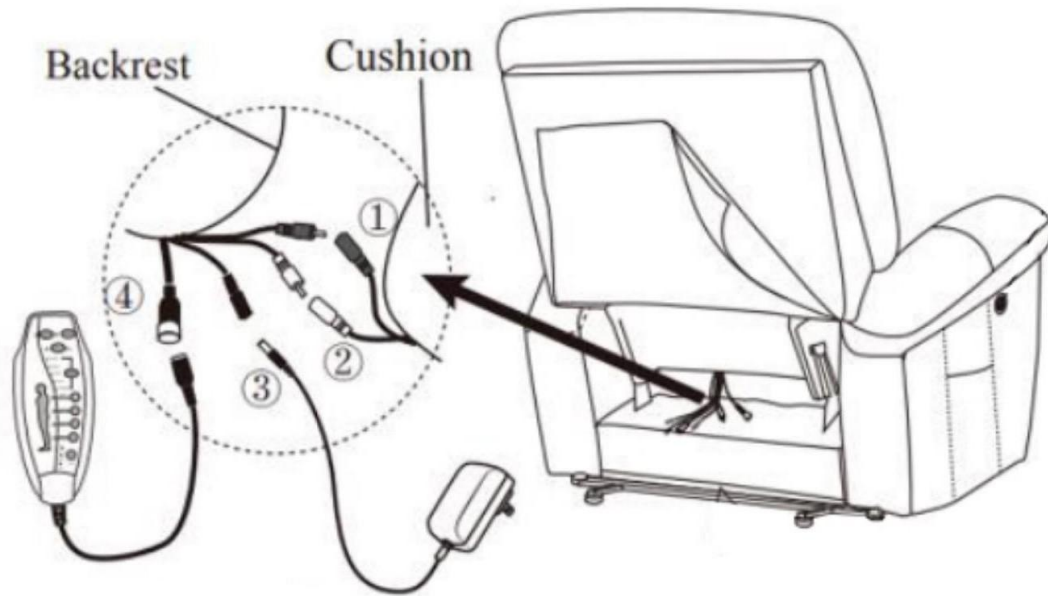

Tips:

The red wire should be connected to the red one.

The white wire should be connected to the white one

Warnings

1. Please check if the components of the chair are all included and can be used normally.
2. Assemble all components according to the instruction correctly before you connect the chair to the power.
3. Please DO NOT sit on the armrests or footrest to eliminate the risk of tipping over.
4. If the chair is damaged or doesn't match the website description, please send clear pictures of the product and label of the carton to our service team for further help.
5. If the recliner doesn't work, you may try the following measures for self-checking firstly:
 - a) Check if all the cables are connected;
 - b) Check if the light of transformer is on.

If the chair still doesn't work, please feed the information back to our customer service in time and we'll help you solve the matter as soon as possible

6. If you have any questions with the product, please contact us by:

Email: customerservice@zoy-living.com(we will reply to you within 24 hours)

