

SIDE TABLE

ASSEMBLY INSTRUCTIONS

PARTS AND FITTING PACKAGING DETAIL

BOX #1

A. TABLE TOP 1PC

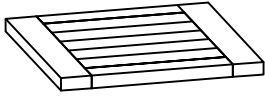

B. LEGS 2PCS

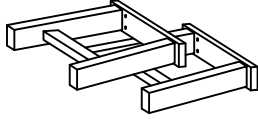

C. CENTER RAIL 1PC







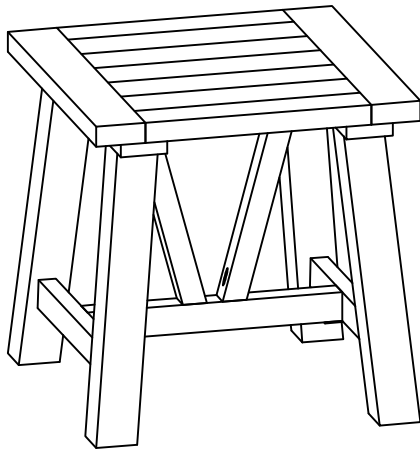

D. SUPPORT BRACE 2PCS



SIDE TABLE ASSEMBLED

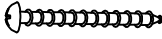

HARDWARE * PACKED IN BOX #1

H1	ALLEN BOLT 8 X 50mm	8 PCS	H2	FLAT WASHER M8	8 PCS
					
H3	ALLEN KEY M4	1 PC	H4	SCREW 4 X 20mm	4 PCS
					
H5	SCREW 4 X 40mm	4 PCS	H6	SPRING WASHER M8	8 PCS
					

YOUR BOX MAY CONTAIN EXTRA HARDWARE

STEP 1

Attach Legs (B) using Allen Bolts (H1), Flat Washers (H2), and Spring Washers (H6). Tighten with Allen Key (H3).

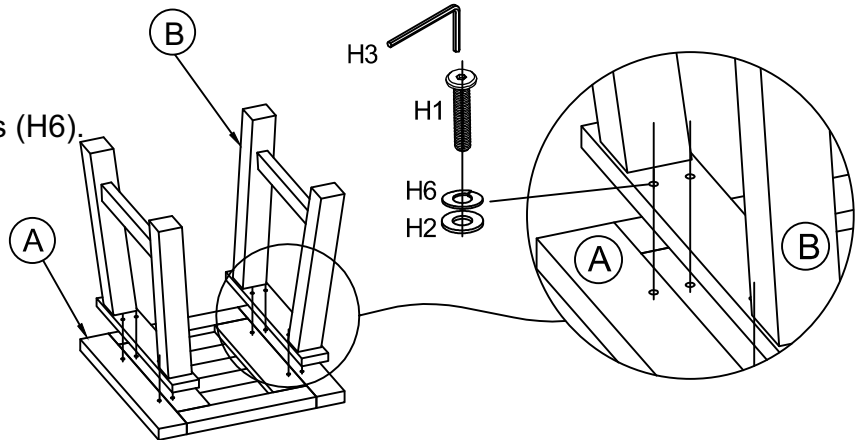

STEP 2

Following the illustration, attach Center Rail (C) to the Legs with Screws (H4). After securing the Center Rail, attach Support Braces (D) to the Table Top and Center Rail using Screws (H5). Screwdriver is not provided.

