











Read this instruction carefully. See hardware and furniture part list for guidance. Be sure all parts are complete, before you assemble. Place all wooden furniture parts on a clean and flat soft surface to prevent from being scratched. Follow the figure to start assembling.

**CAUTIONS :**

1. Do not FULLY - TIGHTEN the nut or nut bolt until all nut or bolt is ready assembled.
2. Do not OVER - TIGHTEN the nut or bolt to avoid causing damages to the thread.
3. Keep all hardware parts out of reach of children.

**NOTE :** THE LIST AND QUANTITY SHOWN ARE FOR 1 UNIT ASSEMBLY  
 Tool needed : Screwdriver & Hammer (not provider).

PART LIST		
ITEM	DESCRIPTION	QTY
A	HEADBOARD	1 PC
B	FOOTBOARD	1 PC
C	SIDE RAIL	2 PCS
D	CENTER RAIL	1 PC
E	CENTER SUPPORT LEG	3 PCS
F	SLAT	1 SET
G	BED LEG	4 PCS
H	SIDE RAIL SUPPORT WOOD	2 PCS
I	HEADBOARD WINGS (L&R)	2 PCS
J	HEADBOARD & FOOTBOARD SUPPORT WOOD	2 PCS

HARDWARE LIST		
ITEM	DESCRIPTION	QTY
1	JCBC BOLT M6 x 40mm 	8 PCS
2	JCBC BOLT M6 x 70mm 	14 PCS
3	JCBB BOLT M8 x 50mm 	8 PCS
4	M6 FLAT WASHER 	4 PCS
5	M8 FLAT WASHER 	8 PCS
6	M8 SPRING WASHER 	8 PCS
7	WOOD SCREW M4 x 38mm 	9 PCS
8	WOOD DOWEL M10 x 30mm 	12 PCS
10	M4 ALLEN KEY (BALL SHAPE) 	1 PC
11	M5 ALLEN KEY (BALL SHAPE) 	1 PC

## STEP 1

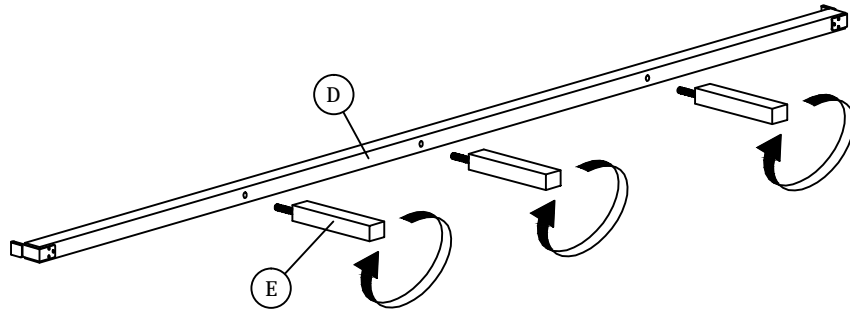

**1.1 Open the zip at the rear side of headboard and take out the headboard wings.**

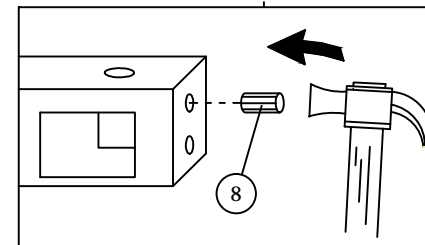
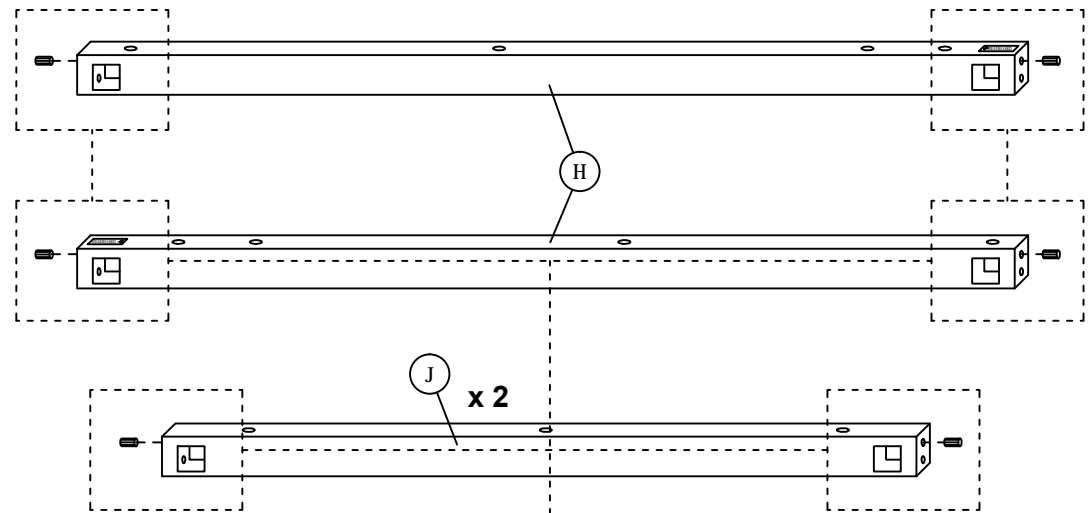
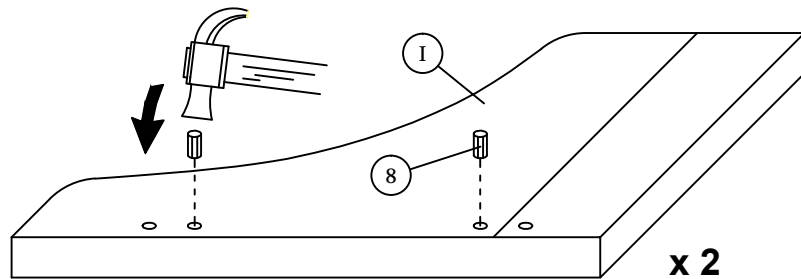

# ASSEMBLY INSTRUCTIONS

## STEP 2

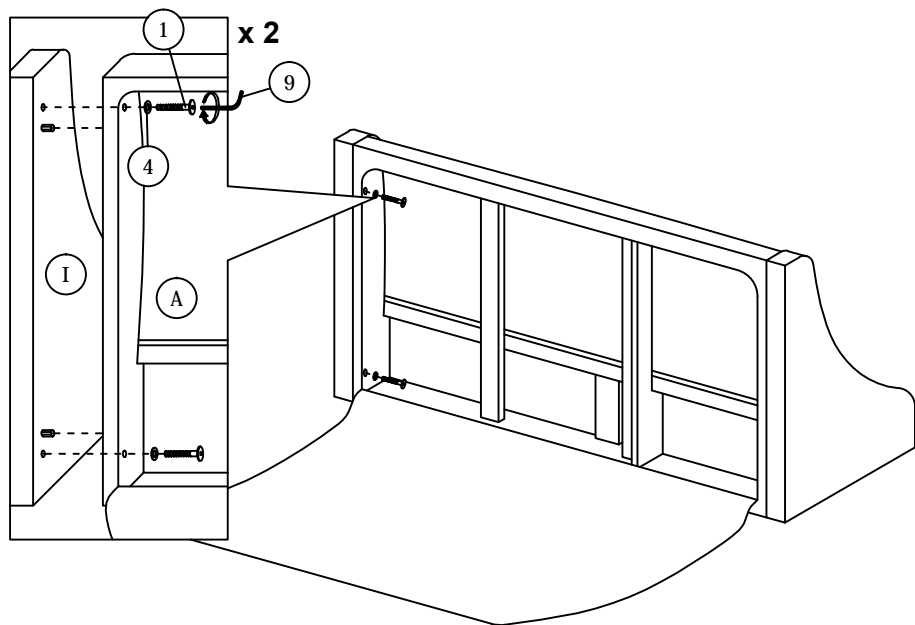

## STEP 3

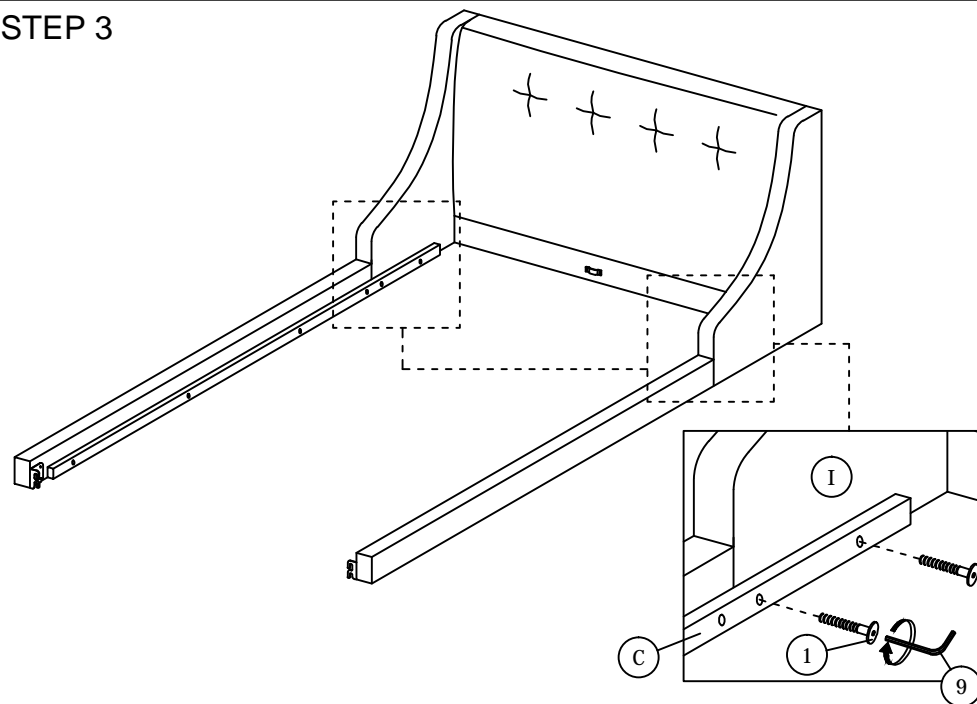

## STEP 4

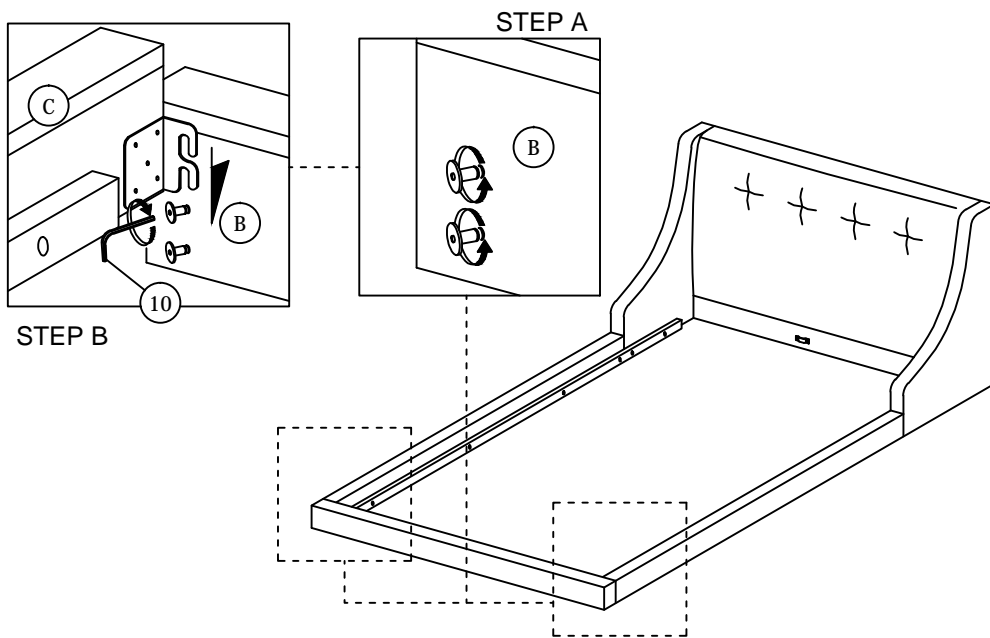

## STEP 5

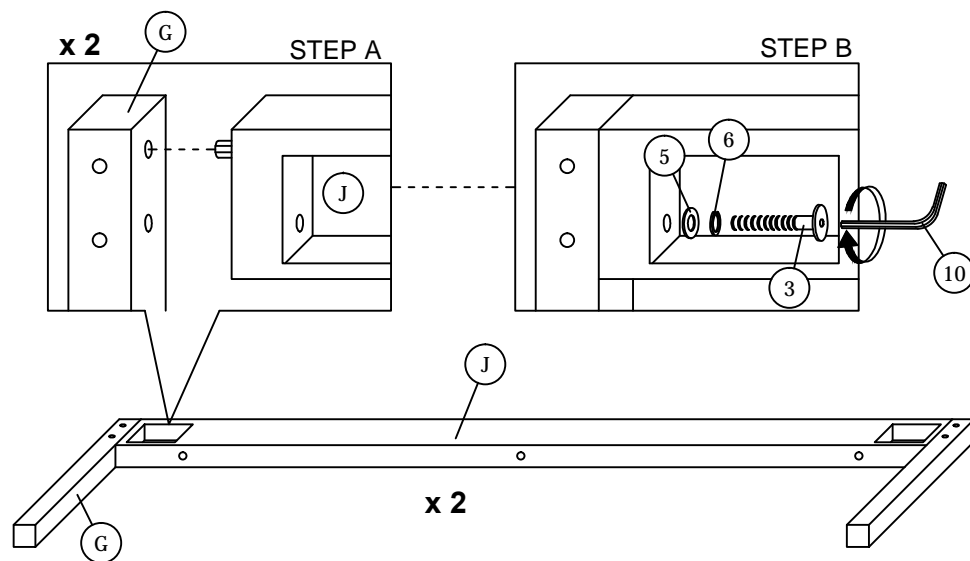

# ASSEMBLY INSTRUCTIONS

## STEP 6

NOTE : Make sure the floor is clean and smooth when put down the bed to prevent scratches.

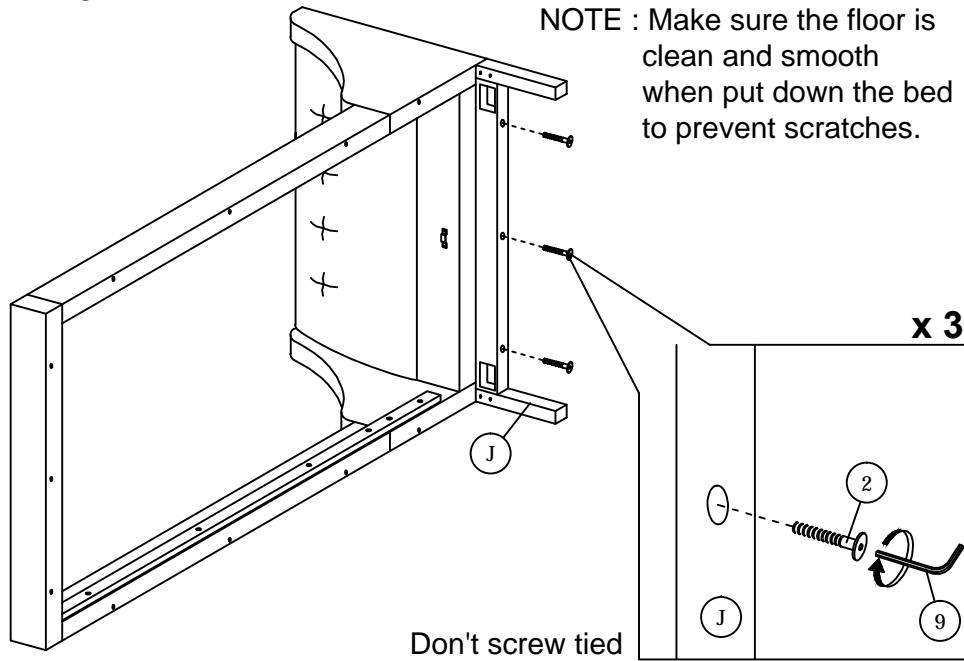

## STEP 8

STEP B Don't screw tied

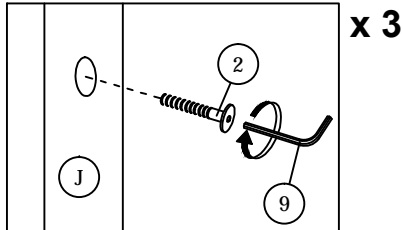

STEP A x 2

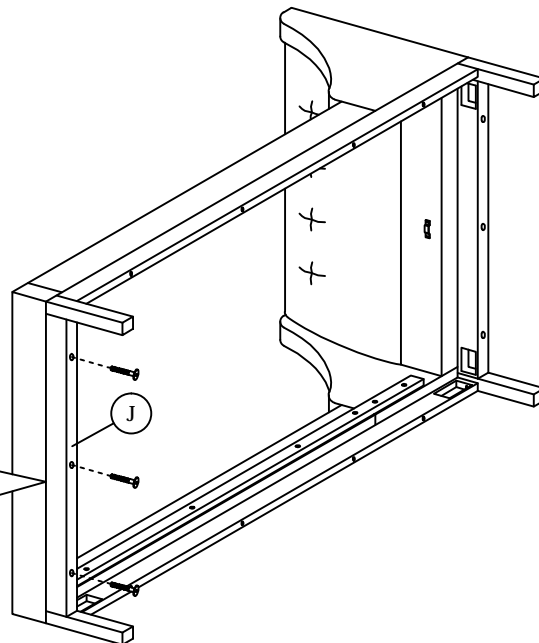
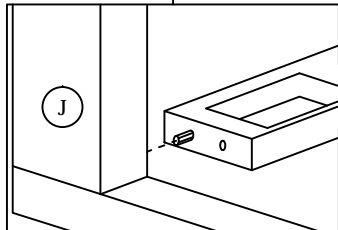

## STEP 7

NOTE : Base on the diagram show 2(i),2(ii),2(iii),2(iv) use the sequence to assembly item H.  
(Make sure the sticker "-> HEADBOARD" faced to headboard [A].)

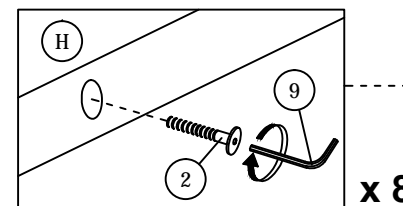
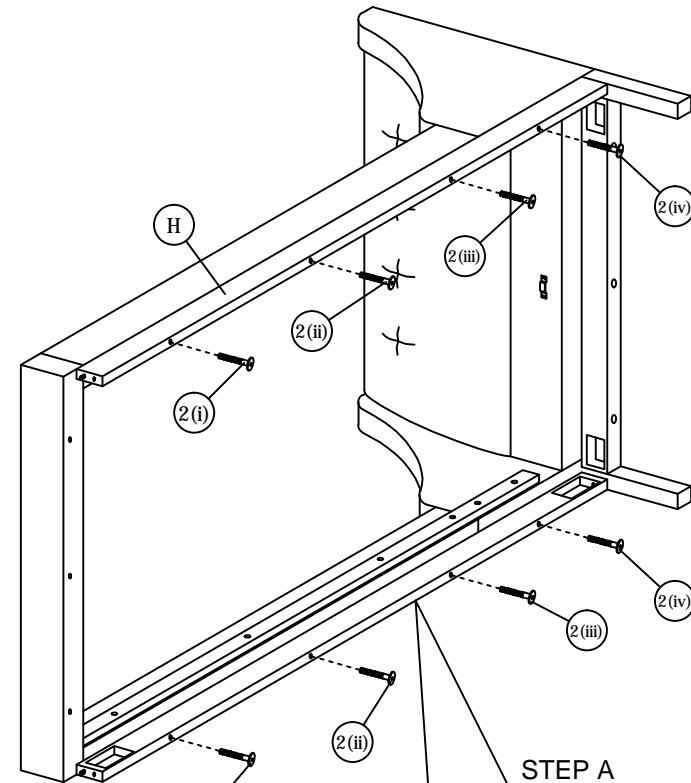

STEP B Don't screw tied

# ASSEMBLY INSTRUCTIONS

## STEP 9

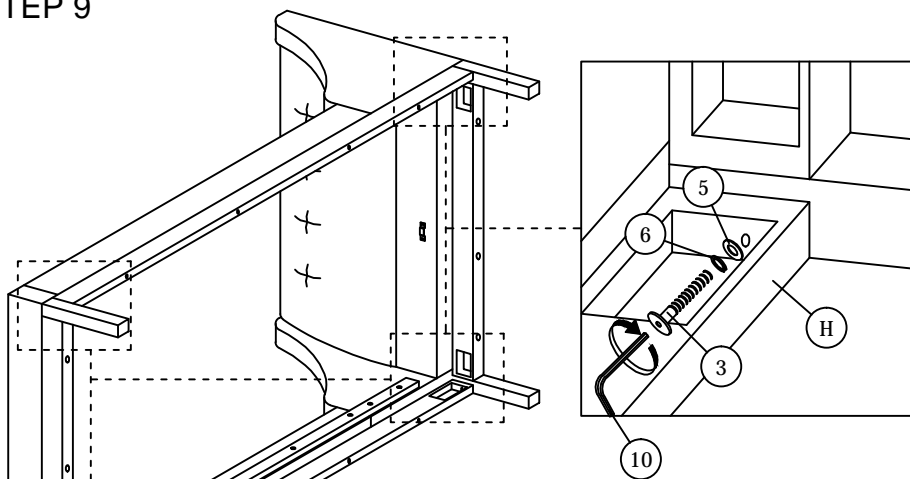

**\*\*Finish step 9,  
Please screw tied the step 6,7,8 bolt.**

## STEP 10

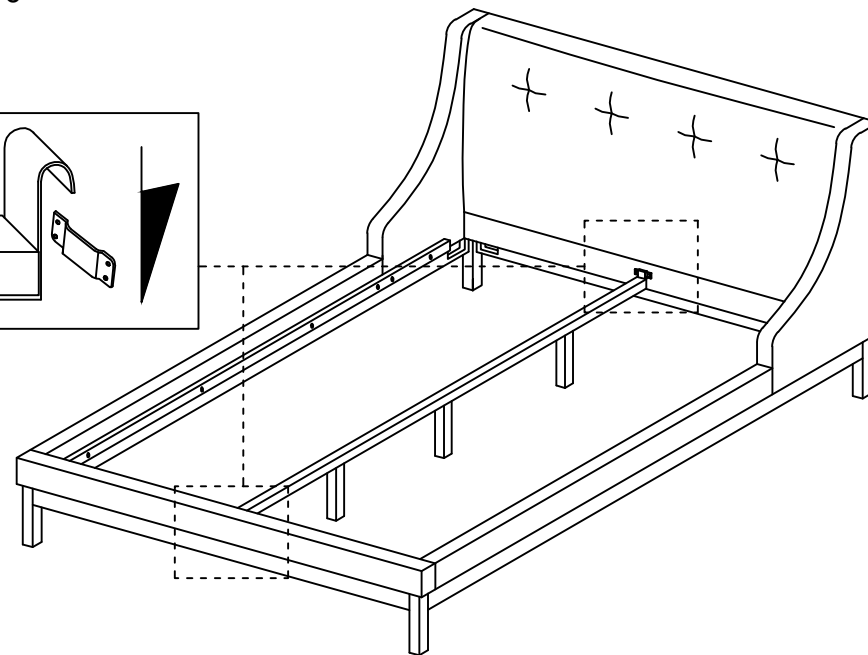
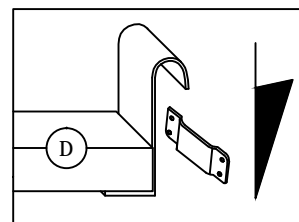

## STEP 11

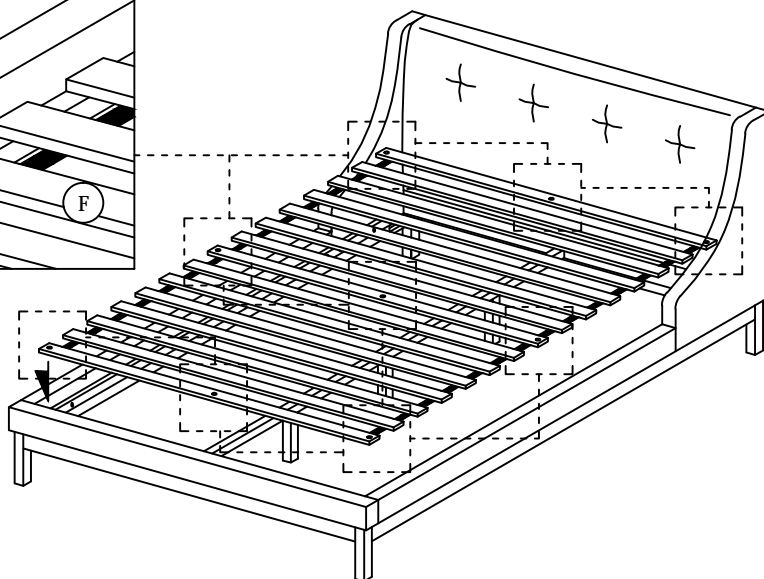
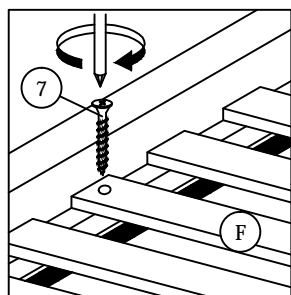

## STEP 12

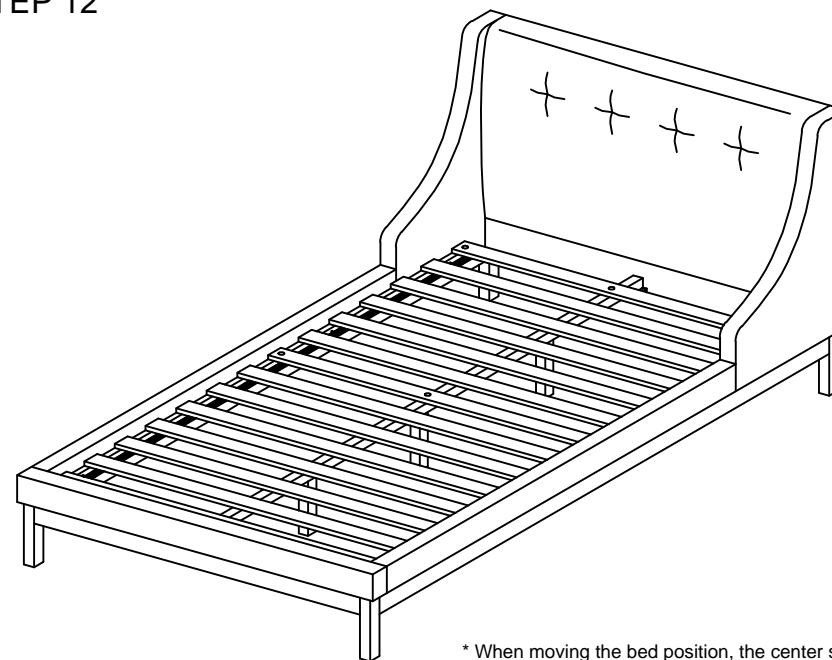

**\* When moving the bed position, the center support legs  
must be adjust to be straight to avoid any broken problem.**