

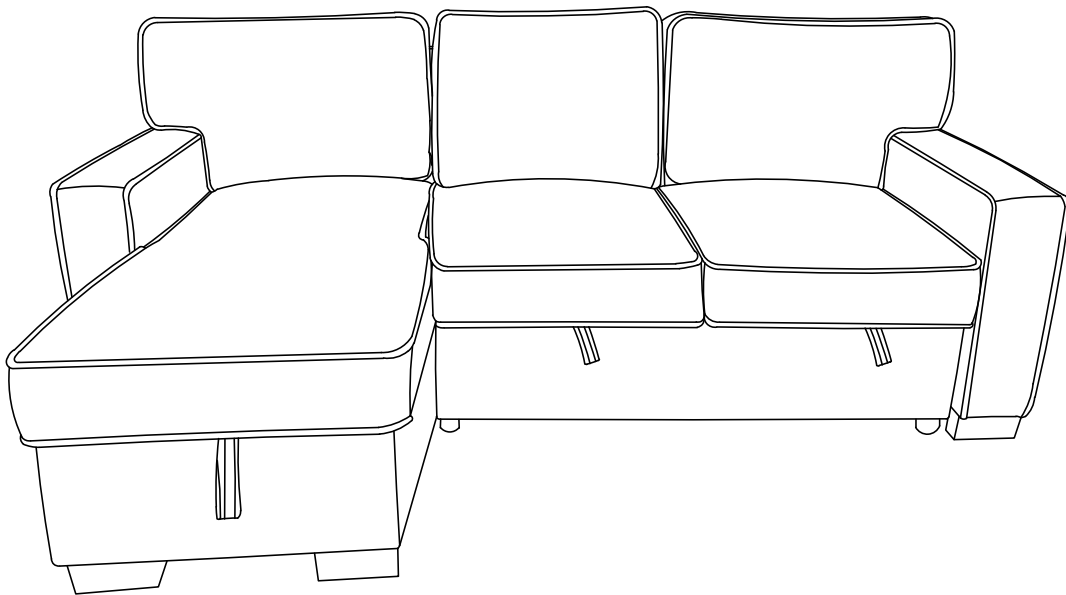

# Assembly Instruction





ITEM NO.: 81353/81353BE

**IMPORTANT: PLACE ALL PARTS ON A CLEAN AND SMOOTH SURFACE SUCH AS A RUG OR CARPETTO AVOID THE PARTS FROM BEING SCRATCHED KINDLY FOLLOW THE ADDEMBLY INSTRUCTIONS STEP DO NOT TIGHTEN ALL SCREWS UNTIL THE BED IS FULLY SET-UP**





# ASSEMBLY INSTRUCTIONS



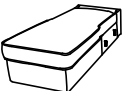

## PARTS LIST

PART	DRAWING	DESCRIPTION	QTY	PART	DRAWING	DESCRIPTION	QTY
A		Love seat	1	C		RAF Back Cushion	1
B		Backrest	1	D		RIGHT Arm	1
E		Backrest	2				



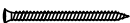

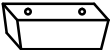



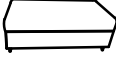

## PARTS LIST

PART	DRAWING	DESCRIPTION	QTY	PART	DRAWING	DESCRIPTION	QTY
F		Chaise	1	H		LAF Back Cushion	1
				I		LEFT Arm	1

## HARDWARE LIST

PART	DRAWING	DESCRIPTION	QTY	PART	DRAWING	DESCRIPTION	QTY
J		Screw M8 x 55mm	18	M		Roller	4
K		Legs	6	N		Screw #8 x 25mm	16
L		Legs	6				

## 81353/81353BE is packed in 3 cases

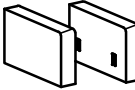
Carton	Disignation	Part		Hardware
81353 /81353BE-1	Love seat	#A		 #Jx18pcs  #Kx6pcs  #Lx6pcs  #Mx4pcs  #Nx16pcs
	Cushion (L&R)	#C/H		
81353 /81353BE-2	Chaise	#F		
	Backrest	#B		
	Backrest	#E		
81353 /81353BE-3	Arm (L&R)	#D/I		

# ASSEMBLY INSTRUCTIONS

THE PARTS ARE LOCATED INSIDE THE BOX AS BELOW:

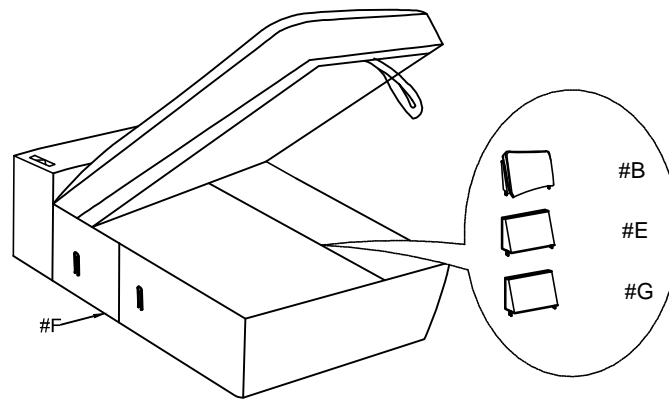
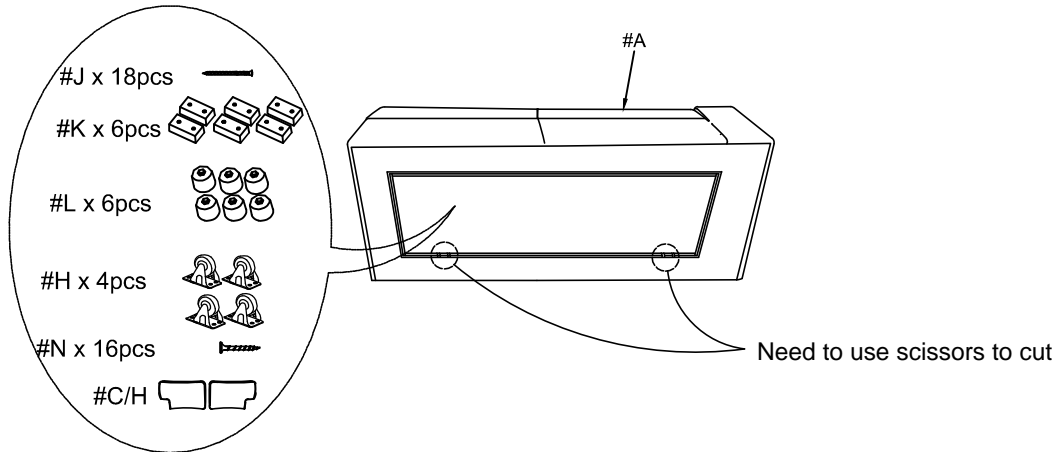

STEP 1

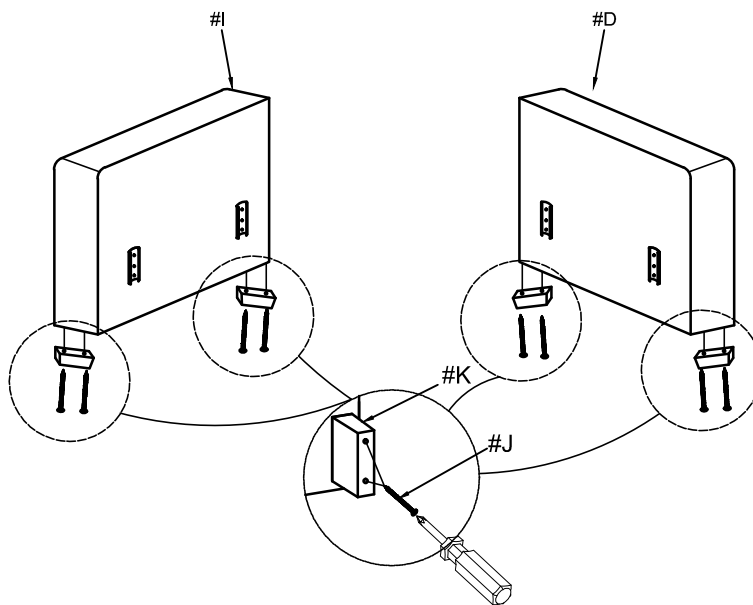

# ASSEMBLY INSTRUCTIONS

## STEP 2

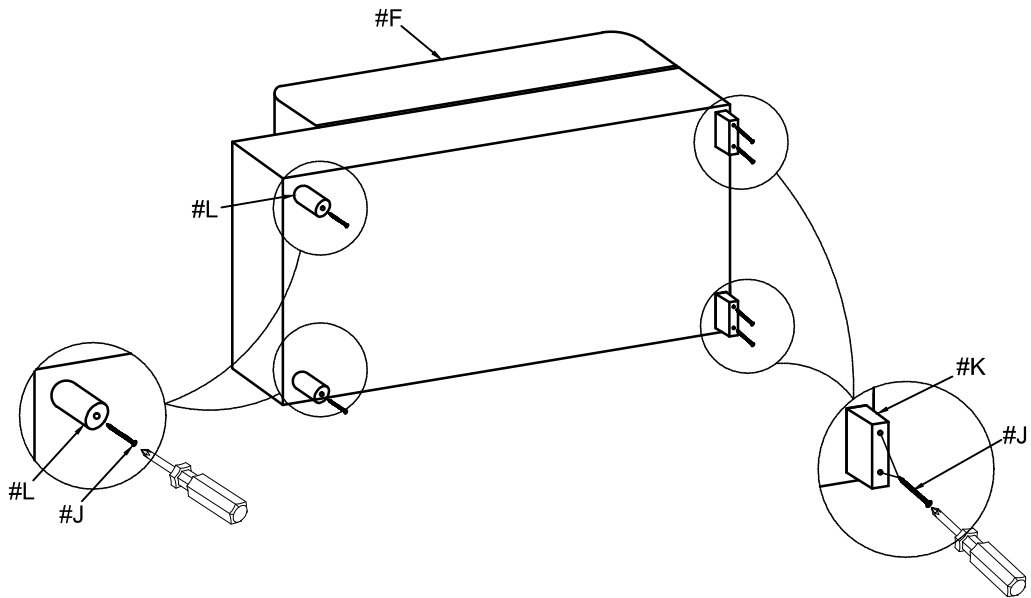

## STEP 3

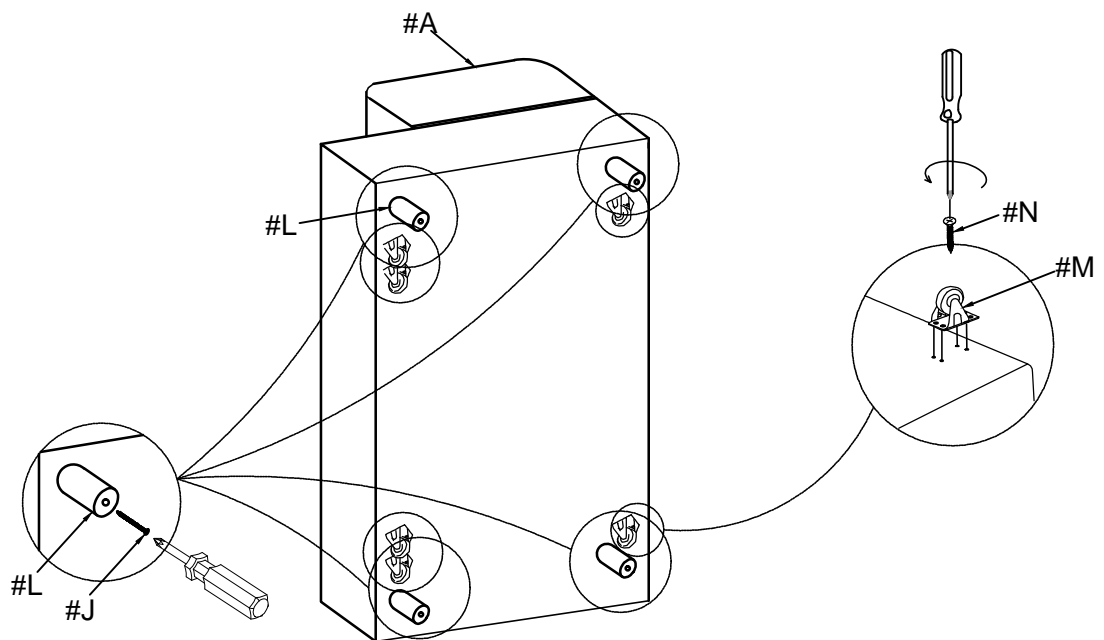

# ASSEMBLY INSTRUCTIONS

## STEP 4

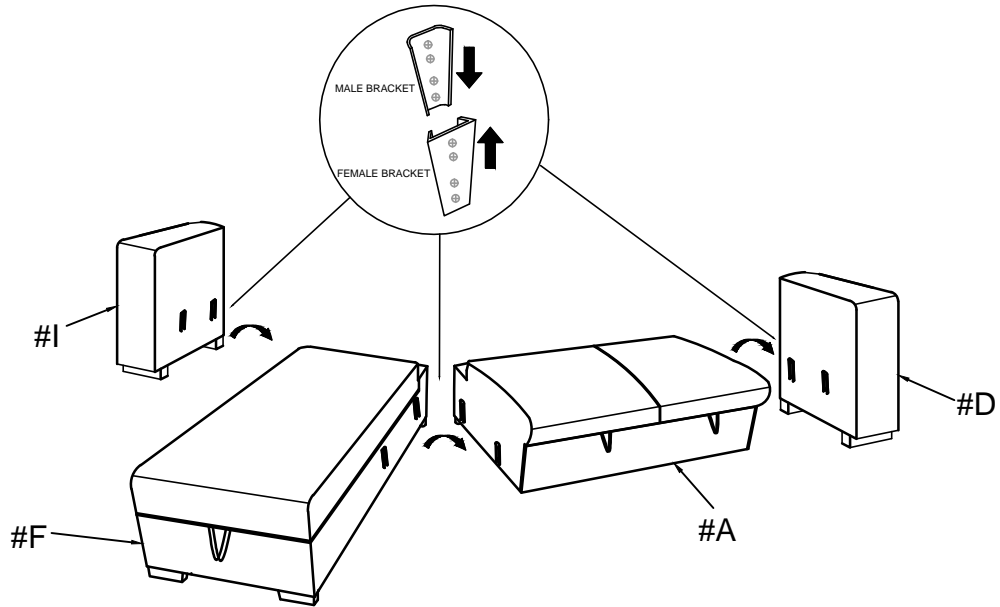

## STEP 5

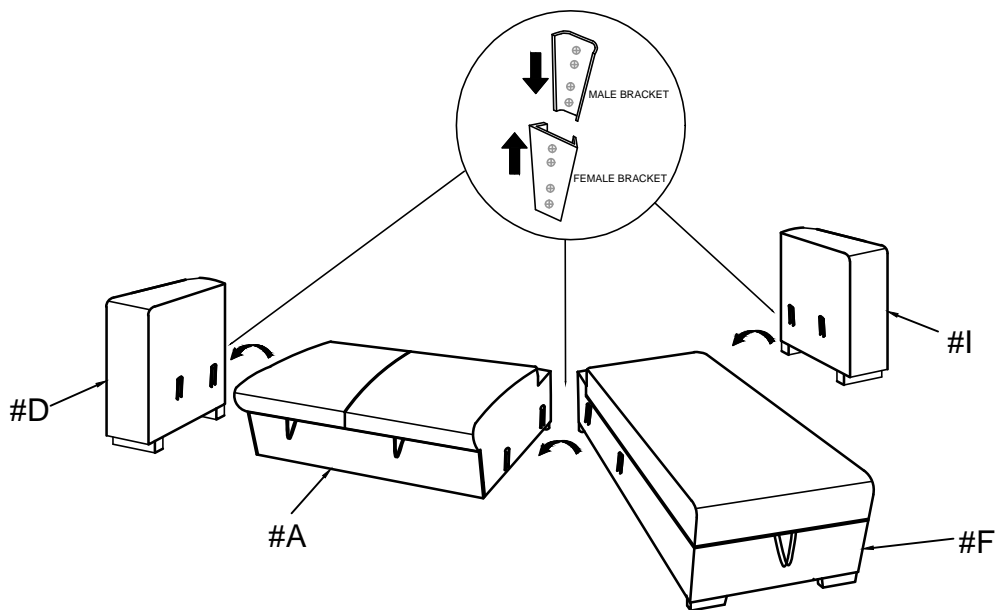

# ASSEMBLY INSTRUCTIONS

## STEP 6

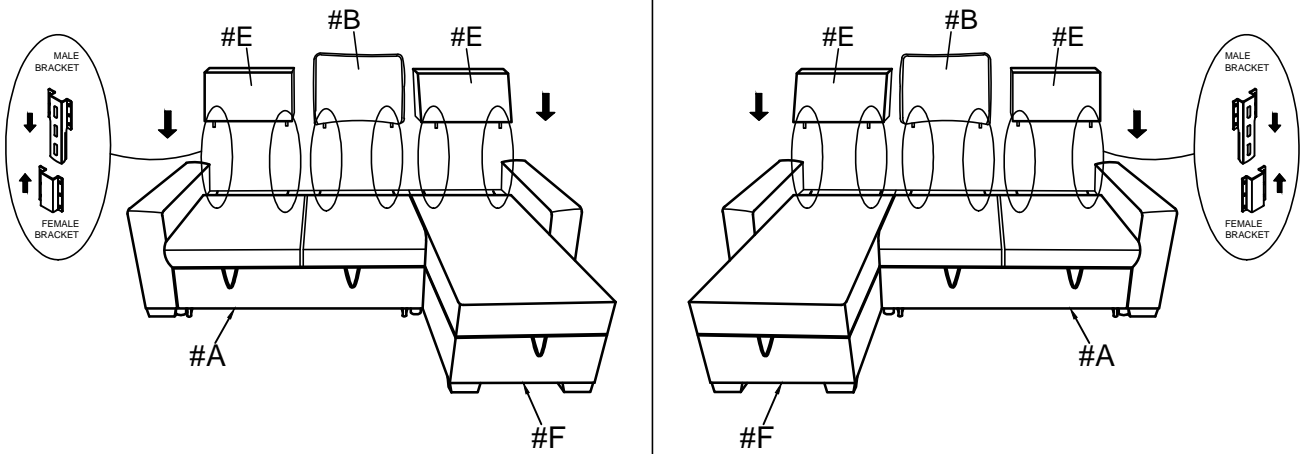

## STEP 7

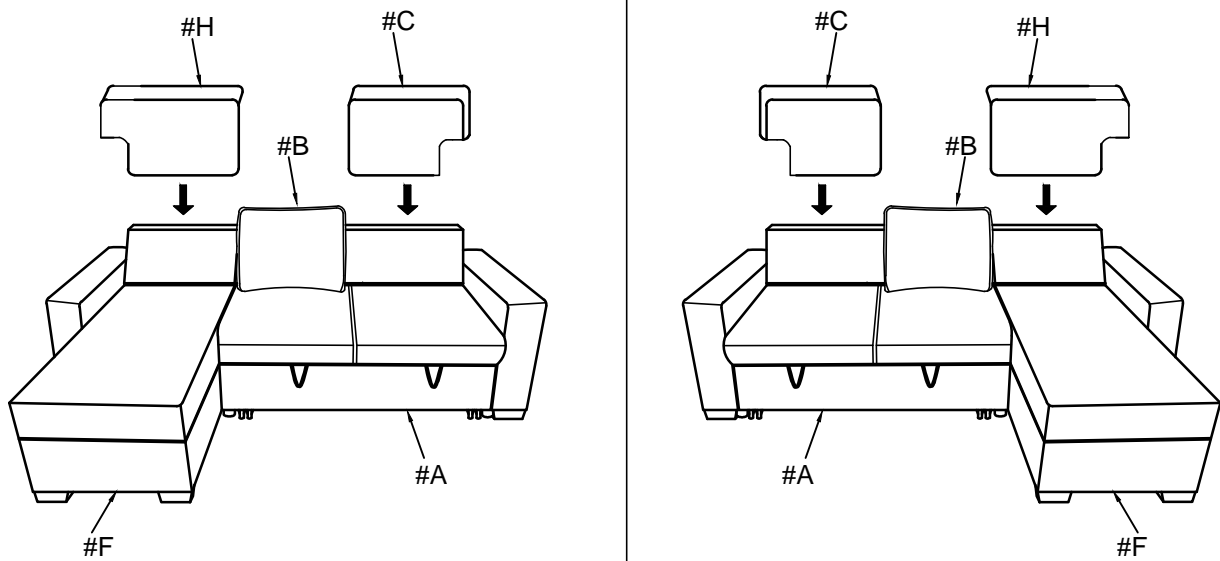

# ASSEMBLY INSTRUCTIONS

STEP 8

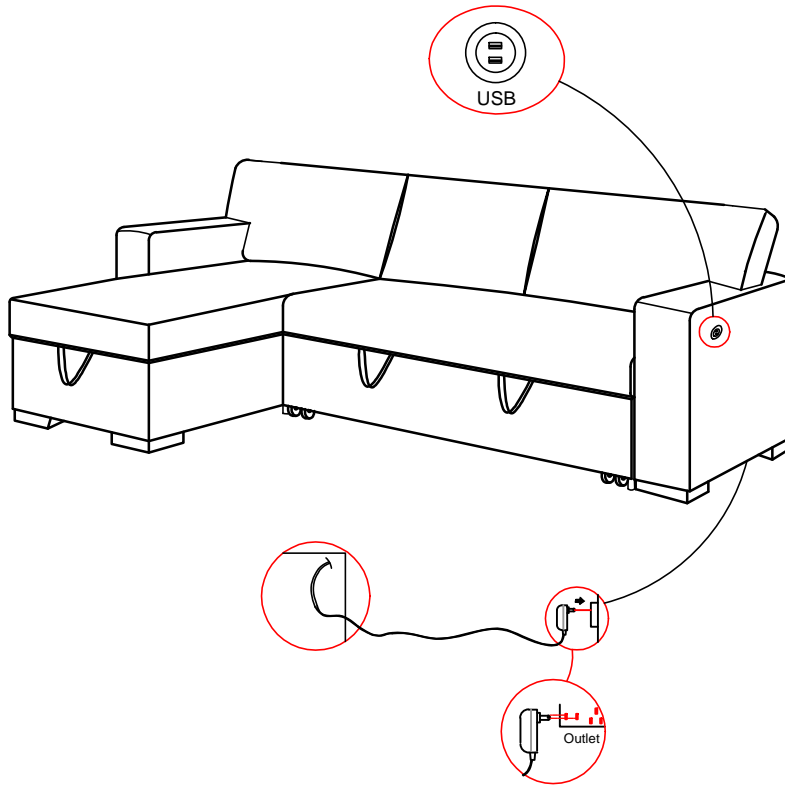

STEP 9

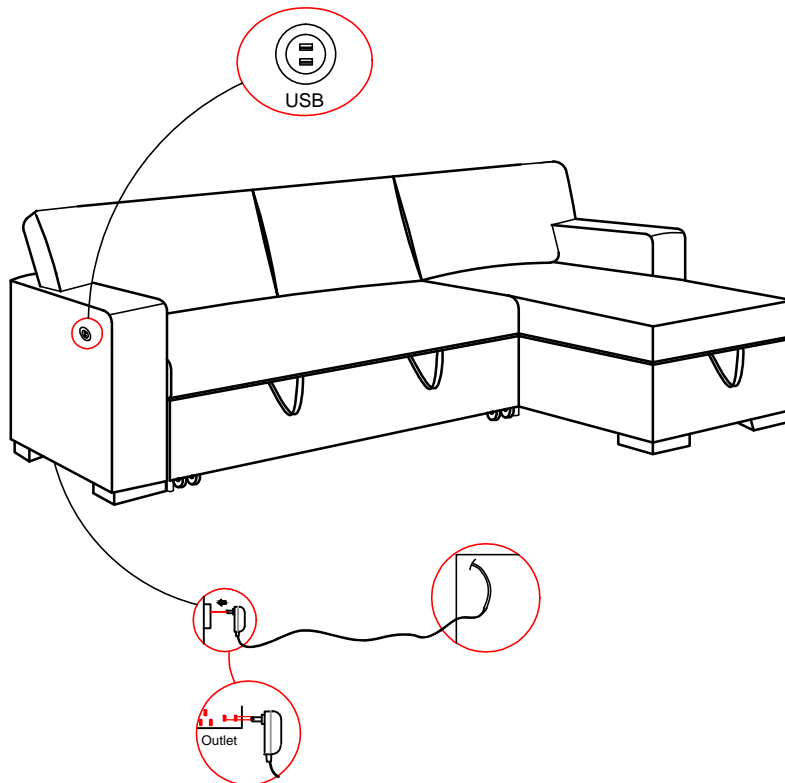

# ASSEMBLY INSTRUCTIONS

STEP 10

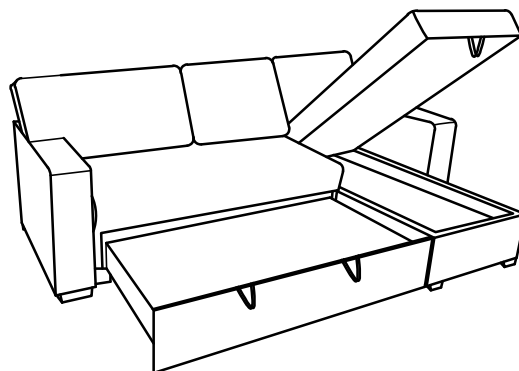
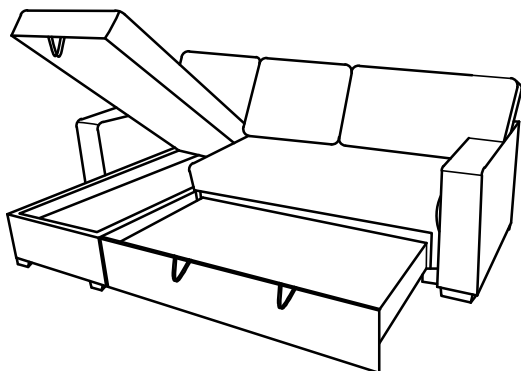

STEP 11

