ASSEMBLY INSTRUCTION







OFFICE CHAIR



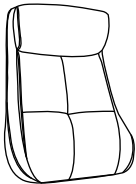

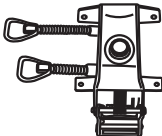

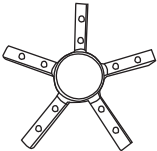
PRE-ASSEMBLY PREPARATION

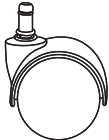
- **CAUTION:** Assembly will require at least 2 adults. DO NOT use power tools. Please inspect all items BEFORE assembly. If for any reason you need to return this item, please kindly return it in it's original packaging.
- **WARNING!**
 1. DO NOT let any sharp objects touch or rub the surface of the product.
 2. When assembling, do not let children play around the working area.
 3. DO NOT tighten all bolts and screws completely until the entire unit has been assembled and set up.
 4. DO NOT USE if this product become damaged, and/or components are broken or missing.
- **CARE AND CLEANING:** DO NOT scratch or chip the finish. DO NOT use abrasive chemicals for cleaning. Clean with mild soap on a soft rag. Rinse and dry thoroughly.
- **MAINTENANCE:** Please periodically check all fittings and re-tighten as necessary.

PARTS LIST

BACKREST (A)  Qty: 1	SEAT (B)  Qty: 1	SEAT PLATE (C)  Qty: 1	GAS LIFT (D)  Qty: 1
BASE (E)  Qty: 1	LEG (F)  Qty: 5	BASE CAP (G)  Qty: 1	WHEEL (H)  Qty: 5

HARDWARE LIST

ALLEN BOLT (I) M6*25MM  Qty: 2	ALLEN BOLT (J) M8*20MM  Qty: 3	ALLEN BOLT (K) M6*16MM  Qty: 10	ALLEN BOLT (L) M6*22MM  Qty: 2	ALLEN WRENCH (M)  Qty: 1
--	--	---	--	---

STEP-BY-STEP ASSEMBLY

PLEASE CAREFULLY UNPACK AND IDENTIFY EACH COMPONENT BEFORE BEGINNING ASSEMBLY. BEFORE YOU BEGIN, PLEASE REFER TO PARTS LIST TO MAKE SURE THAT YOU HAVE ALL PARTS.

STEP 1 Insert the Legs(F) to the Five-jaw Base(E) by using Allen Bolt (K) and Allen Wrench (M).

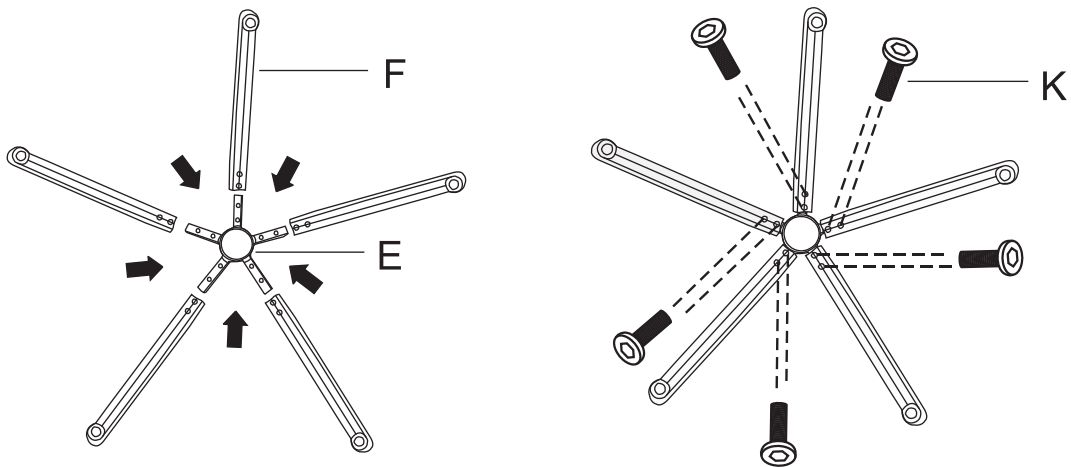

STEP 2 Insert the Base Cap (G) and Gas Lift (D) to the Five-jaw Base (E) , then snap in the Wheels (H) as shown below.

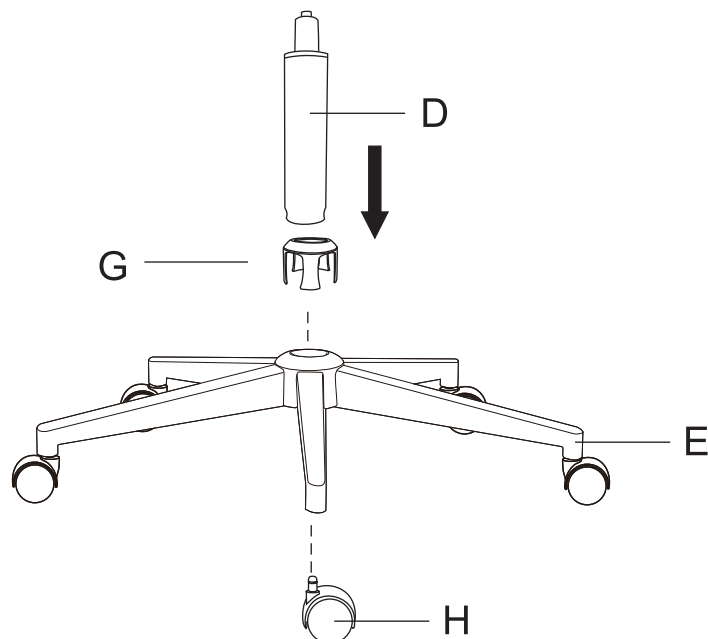

STEP 3 Attach the Seat Plate (C) to the Seat (B) by using Allen Bolt(I&) Wrench (M).

Please 80% tighten the bolts.

Allen Bolt I is used to tighten the front side, and Allen Bolt L is used for the back side.

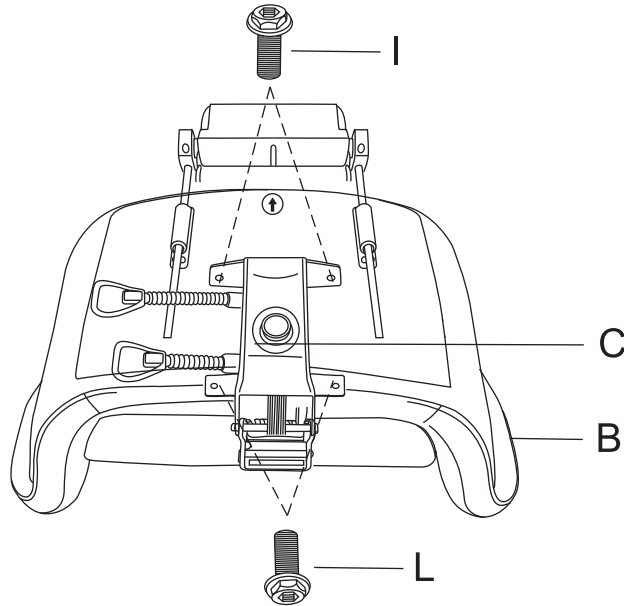

STEP 4 Insert the Gas Lift (D) to the Seat Plate (C) as shown in below diagram.

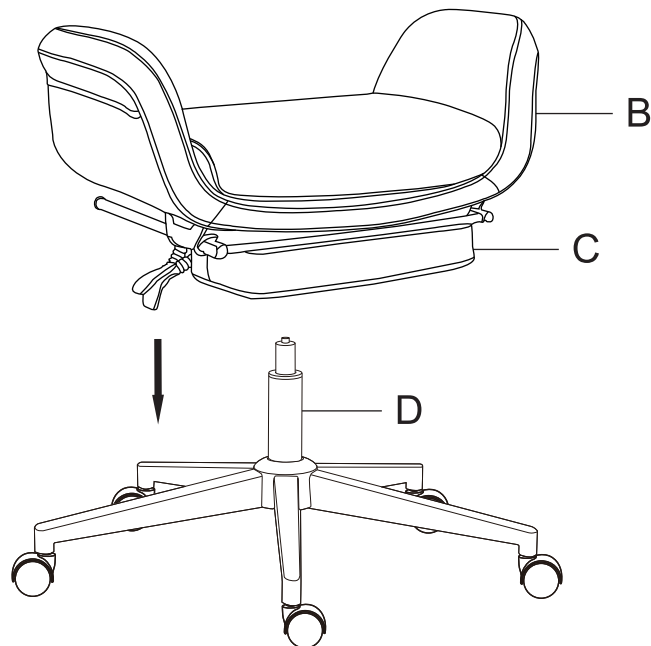

STEP 5 Attach the Backrest (A) to the Seat (B) by using Allen Bolt (J) and Allen Wrench (M) as shown in below diagram.

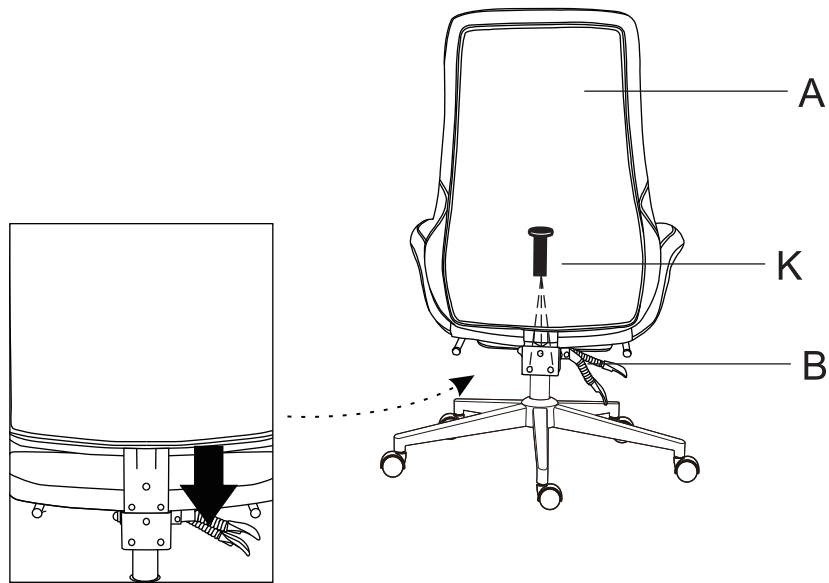

STEP 6 In this step please make sure the chair is flat and all bolts are installed, then finally 100% tighten all bolts.

A few days after initial assembly, the product may acclimate to its new environment.

Please ensure all screws are still securely tightened.

