

**INSTRUCTIONS D'ASSEMBLAGE  
ASSEMBLY INSTRUCTIONS**



**BUREAU - CAPPUCCINO EN COIN DROIT OU GAUCHE  
COMPUTER DESK - CAPPUCCINO LEFT OR RIGHT FACING CORNER**



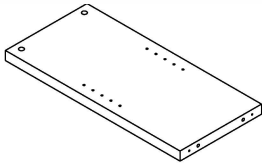
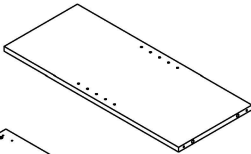
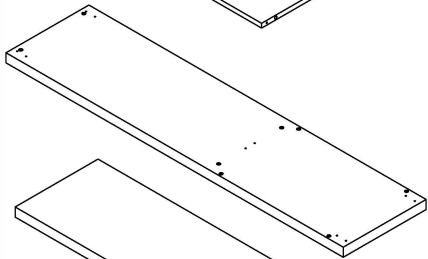
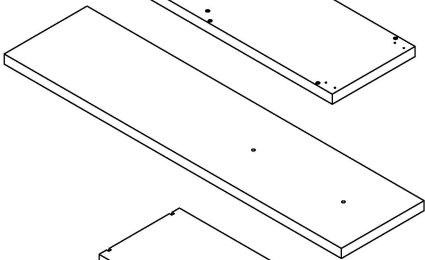
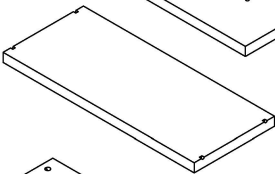
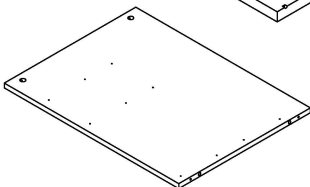
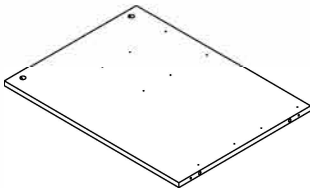
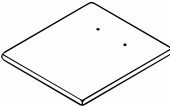
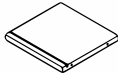

**POUR DE L'ASSISTANCE OU POUR COMMANDER  
DES PIÈCES CONTACTEZ NOTRE DÉPARTEMENT  
DE SERVICE À LA CLIENTÈLE.**

**FOR ASSISTANCE OR TO ORDER PARTS  
CONTACT OUR CUSTOMER SERVICE DEPARTMENT**





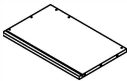
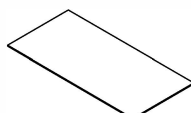
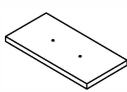

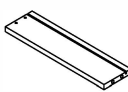
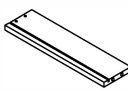
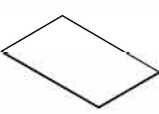
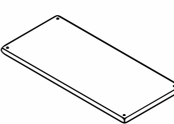
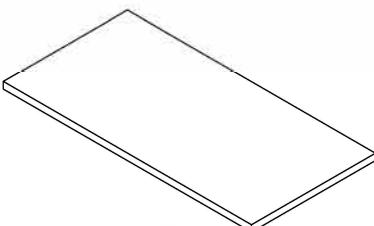
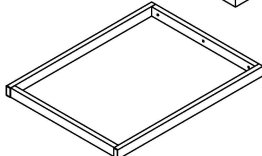



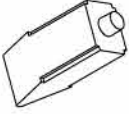
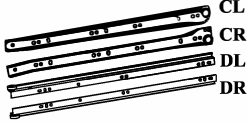
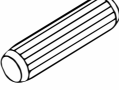

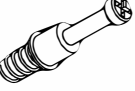
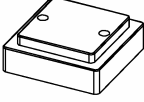
## IDENTIFICATION DES PIÈCES PARTS IDENTIFICATION

<b>1</b>		<b>PANNEAU CÔTÉ GAUCHE</b> <b>LEFT SIDE PANEL</b>	<b>1MC</b> <b>1PC</b>
<b>2</b>		<b>PANNEAU CÔTÉ DROIT</b> <b>RIGHT SIDE PANEL</b>	<b>1MC</b> <b>1PC</b>
<b>3</b>		<b>PANNEAU DU BAS</b> <b>BOTTOM PANEL</b>	<b>1MC</b> <b>1PC</b>
<b>4</b>		<b>PANNEAU DU DESSUS</b> <b>TOP PANEL</b>	<b>1MC</b> <b>1PC</b>
<b>5</b>		<b>PANNEAU AJUSTABLE</b> <b>ADJUSTABLE PANEL</b>	<b>1MC</b> <b>1PC</b>
<b>6</b>		<b>PANNEAU DE DIVISION</b> <b>DIVIDER PANEL</b>	<b>1MC</b> <b>1PC</b>
<b>7</b>		<b>PANNEAU DE DIVISION</b> <b>DIVIDER PANEL</b>	<b>1MC</b> <b>1PC</b>
<b>8</b>		<b>PANNEAU DEVANT DU TIROIR</b> <b>DRAWER FRONT PANEL</b>	<b>1MC</b> <b>1PC</b>
<b>9</b>		<b>PANNEAU ARRIÈRE DU TIROIR</b> <b>DRAWER BACK PANEL</b>	<b>1MC</b> <b>1PC</b>
<b>10</b>		<b>PANNEAU CÔTÉ GAUCHE DU TIROIR</b> <b>LEFT DRAWER SIDE PANEL</b>	<b>1MC</b> <b>1PC</b>

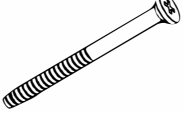

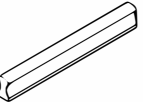
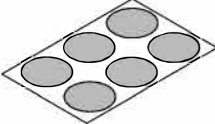

## IDENTIFICATION DES PIÈCES PARTS IDENTIFICATION

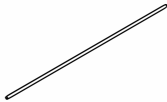
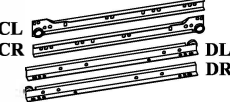
<b>11</b>		<b>PANNEAU CÔTÉ DROIT DU TIROIR</b> <b>RIGHT DRAWER SIDE PANEL</b>	<b>1MC</b> <b>1PC</b>
<b>12</b>		<b>PANNEAU DU FOND DU TIROIR</b> <b>DRAWER BOTTOM PANEL</b>	<b>1MC</b> <b>1PC</b>
<b>13</b>		<b>PANNEAU DEVANT DU TIROIR</b> <b>DRAWER FRONT PANEL</b>	<b>2MCX</b> <b>2PCS</b>
<b>14</b>		<b>PANNEAU ARRIÈRE DU TIROIR</b> <b>DRAWER BACK PANEL</b>	<b>2MCX</b> <b>2PCS</b>
<b>15</b>		<b>PANNEAU CÔTÉ GAUCHE DU TIROIR</b> <b>LEFT DRAWER SIDE PANEL</b>	<b>2MCX</b> <b>2PCS</b>
<b>16</b>		<b>PANNEAU CÔTÉ DROIT DU TIROIR</b> <b>RIGHT DRAWER SIDE PANEL</b>	<b>2MCX</b> <b>2PCS</b>
<b>17</b>		<b>PANNEAU DU FOND DU TIROIR</b> <b>DRAWER BOTTOM PANEL</b>	<b>2MCX</b> <b>2PCS</b>
<b>18</b>		<b>PANNEAU DE TABLE DE CLOISON</b> <b>TABLE TOP PARTITION BOARD</b>	<b>1MC</b> <b>1PC</b>
<b>19</b>		<b>DESSUS DE TABLE</b> <b>TABLE TOP</b>	<b>1MC</b> <b>1PC</b>
<b>20</b>		<b>PATTE</b> <b>LEG</b>	<b>1MC</b> <b>1PC</b>

## IDENTIFICATION DES PIÈCES DE MONTAGE HARDWARE IDENTIFICATION

<b>A</b>		COLLE/GLUE(40g)	1MC / PC	<b>K</b>		450mm	1 ENS / SET
<b>B</b>		∅8 x 30mm	24MCX / PCS	<b>L</b>		12mm	38MCX / PCS
<b>C</b>		35mm	14MCX / PCS	<b>M</b>		50x50x18mm	5MCX / PCS
<b>D</b>		∅15x12mm	14MCX / PCS	<b>N</b>		23mm	10MCX / PCS
<b>E</b>		35mm	16MCX / PCS	<b>O</b>		42mm	2MCX / PCS
<b>F</b>		55mm	8MCX / PCS	<b>P</b>		38mm	3MCX / PCS
<b>G</b>		∅4.9x15mm	4MCX / PCS	<b>Q</b>		ALLEN WRENCH 57x21mm	1MC / PC
<b>H</b>		120mm	3MCX / PCS	<b>R</b>		∅20mm	3MCX / PCS
<b>I</b>		23mm	6MCX / PCS	<b>S</b>		225mm	2MCX / PCS
<b>J</b>		350mm	2 ENS / SET				

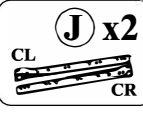
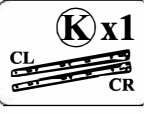
ÉTAPE / STEP 1

-  **(B)**  
x 16
-  **(C)**  
x 8
-  **(J) x2**  
CL CR
-  **(K) x1**  
CL CR
-  **(L)**  
x 20

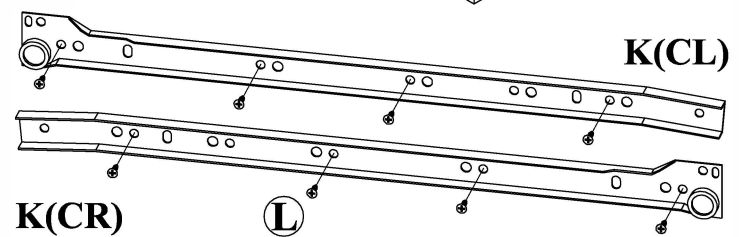
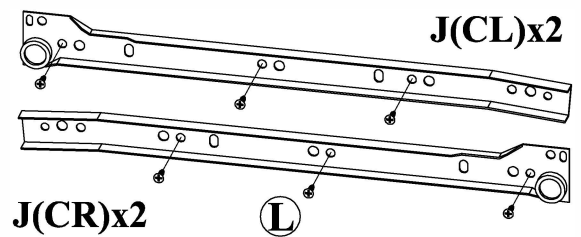
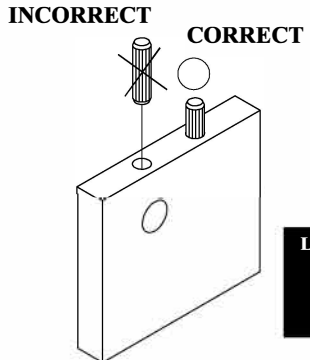
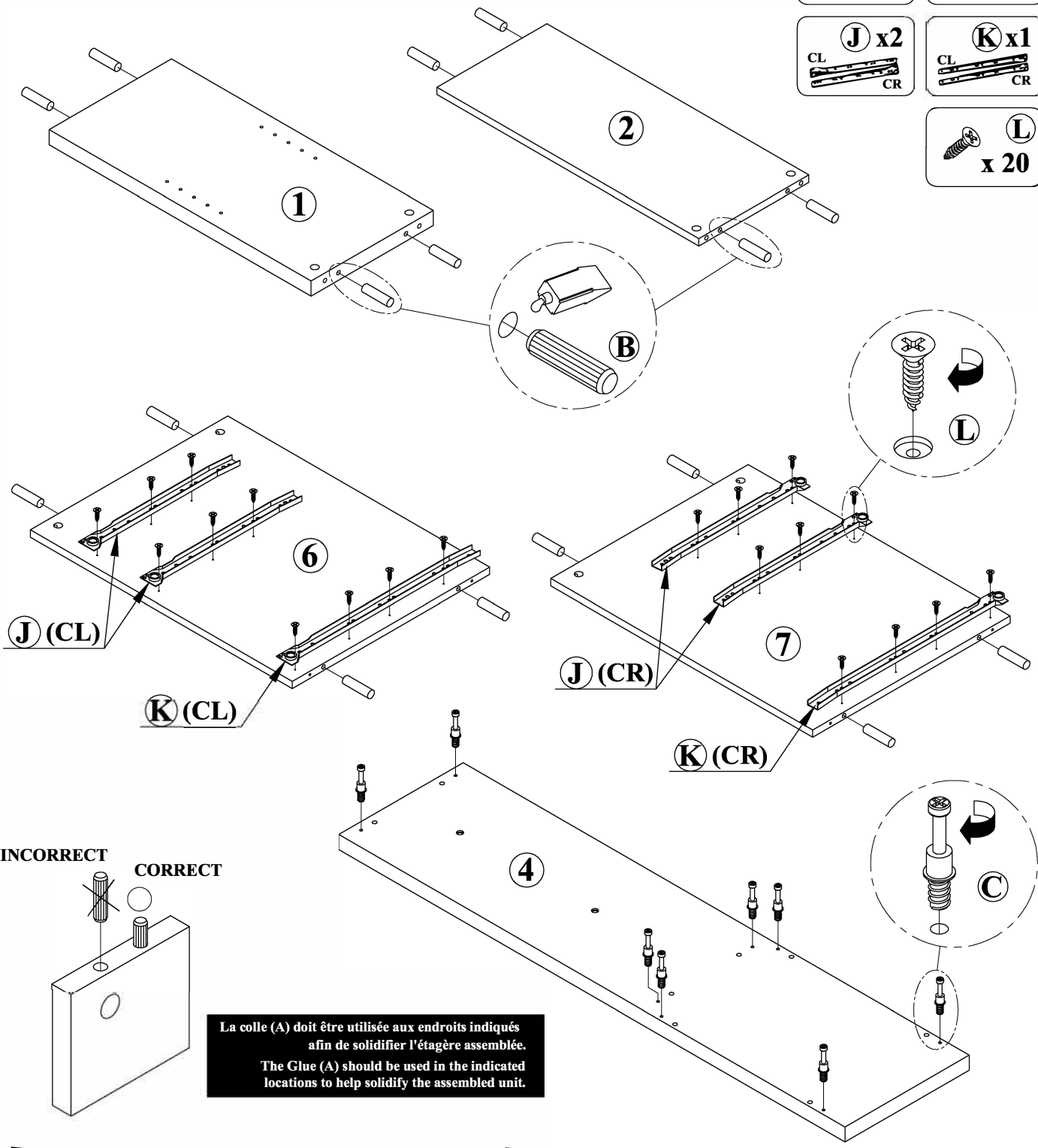

## ÉTAPE / STEP 2

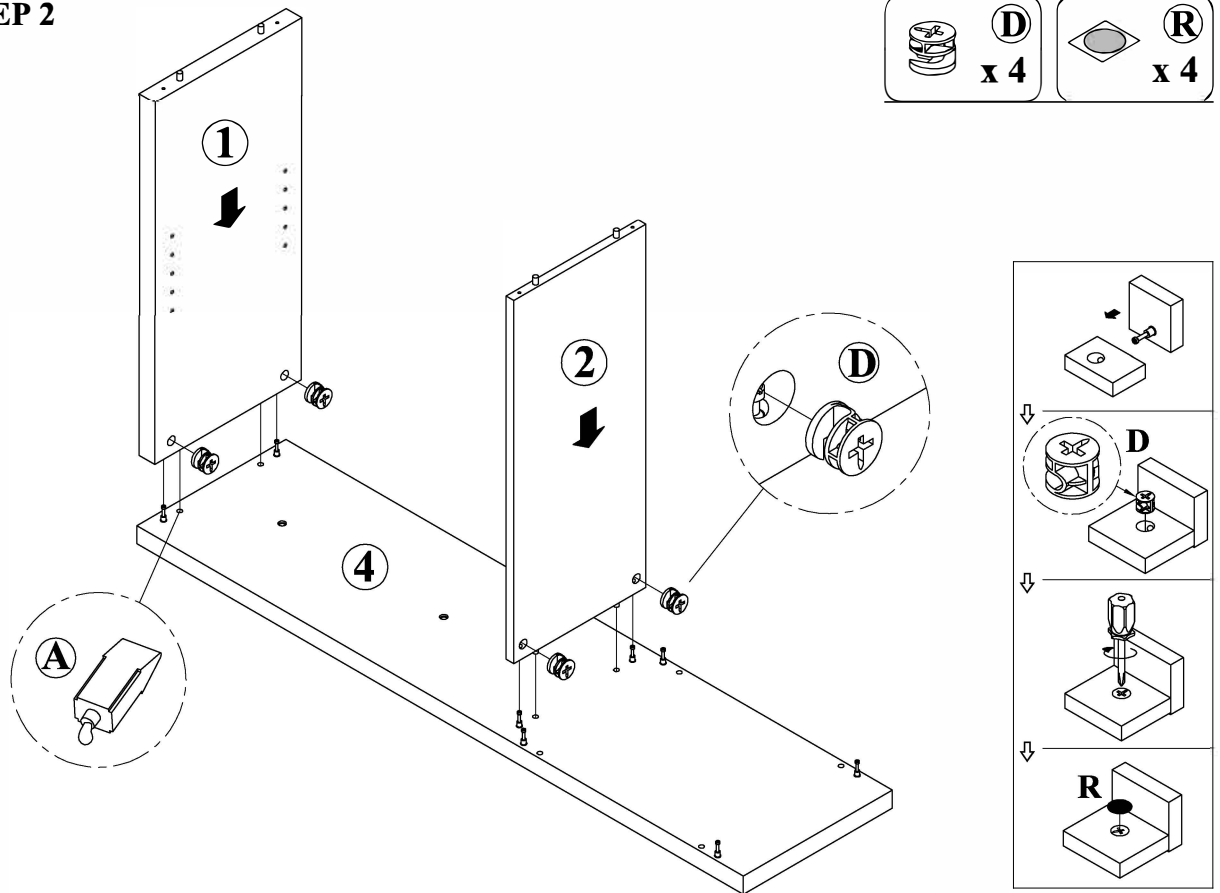

## ÉTAPE / STEP 3

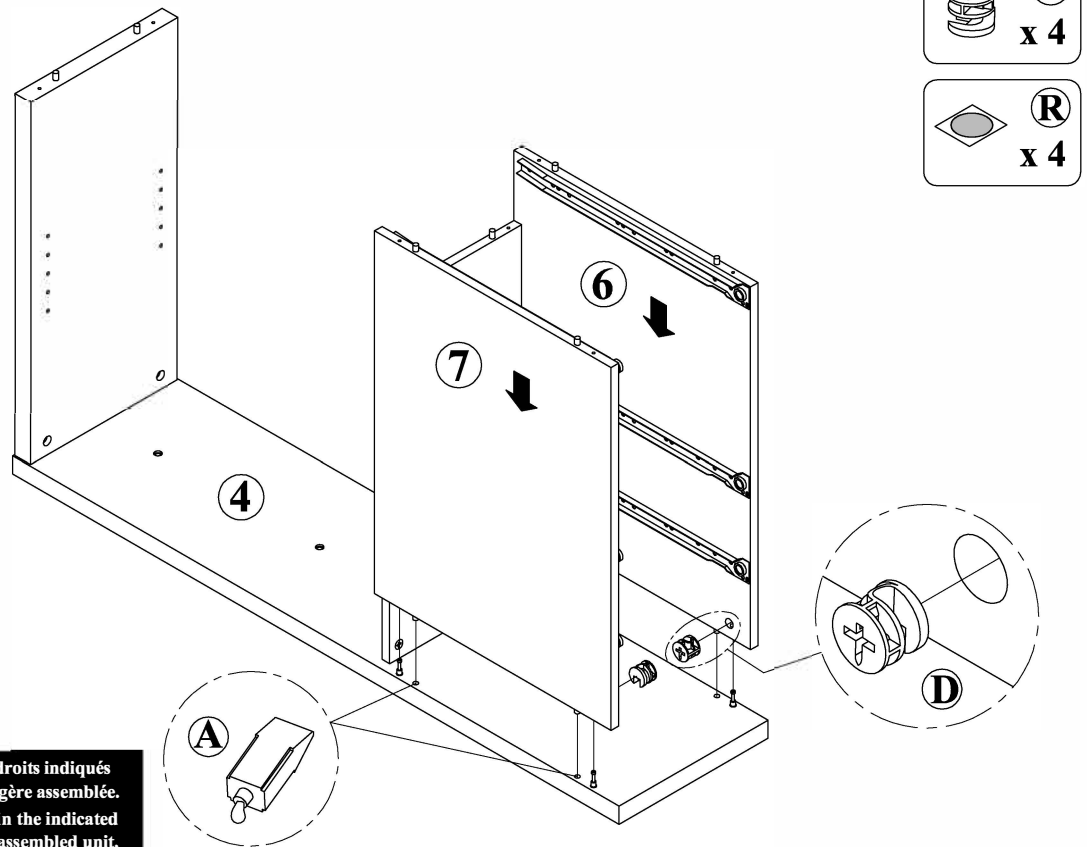

La colle (A) doit être utilisée aux endroits indiqués afin de solidifier l'étagère assemblée.  
The Glue (A) should be used in the indicated locations to help solidify the assembled unit.

## ÉTAPE / STEP 4

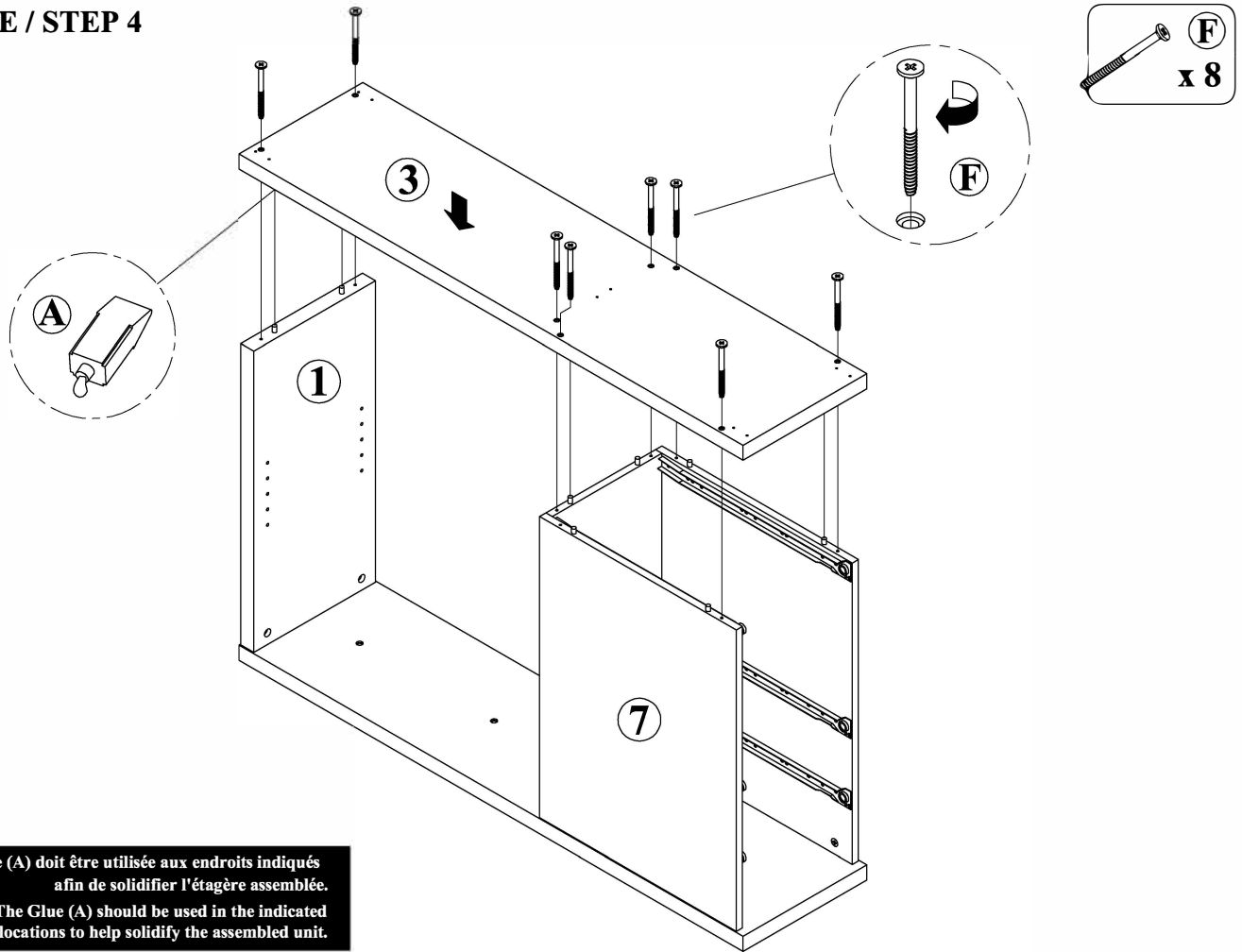

## ÉTAPE / STEP 5

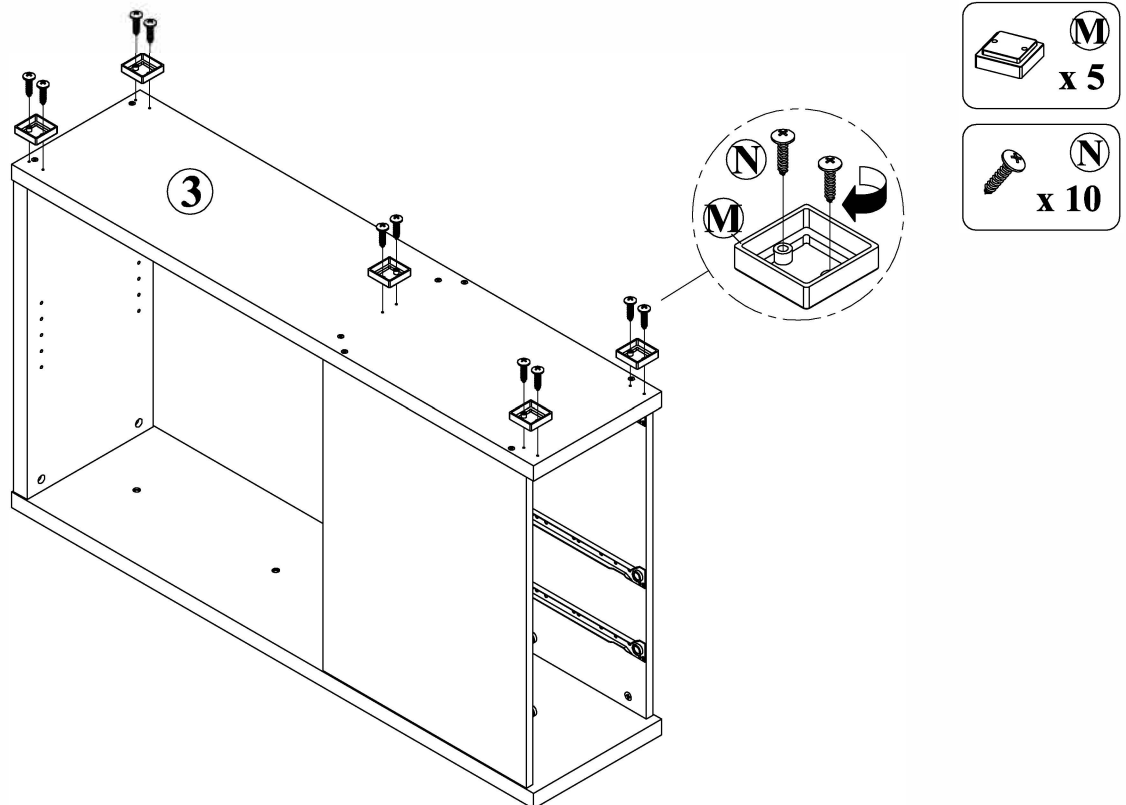

ÉTAPE / STEP 6

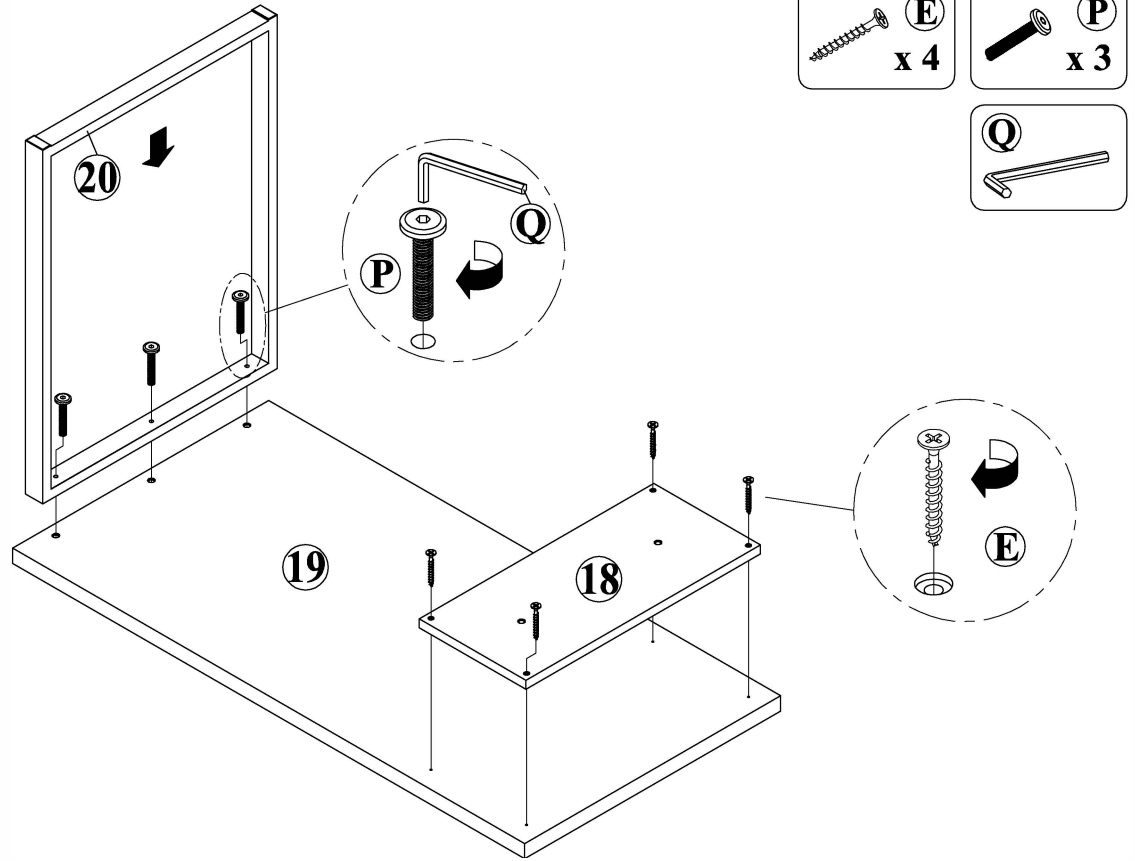

ÉTAPE / STEP 7

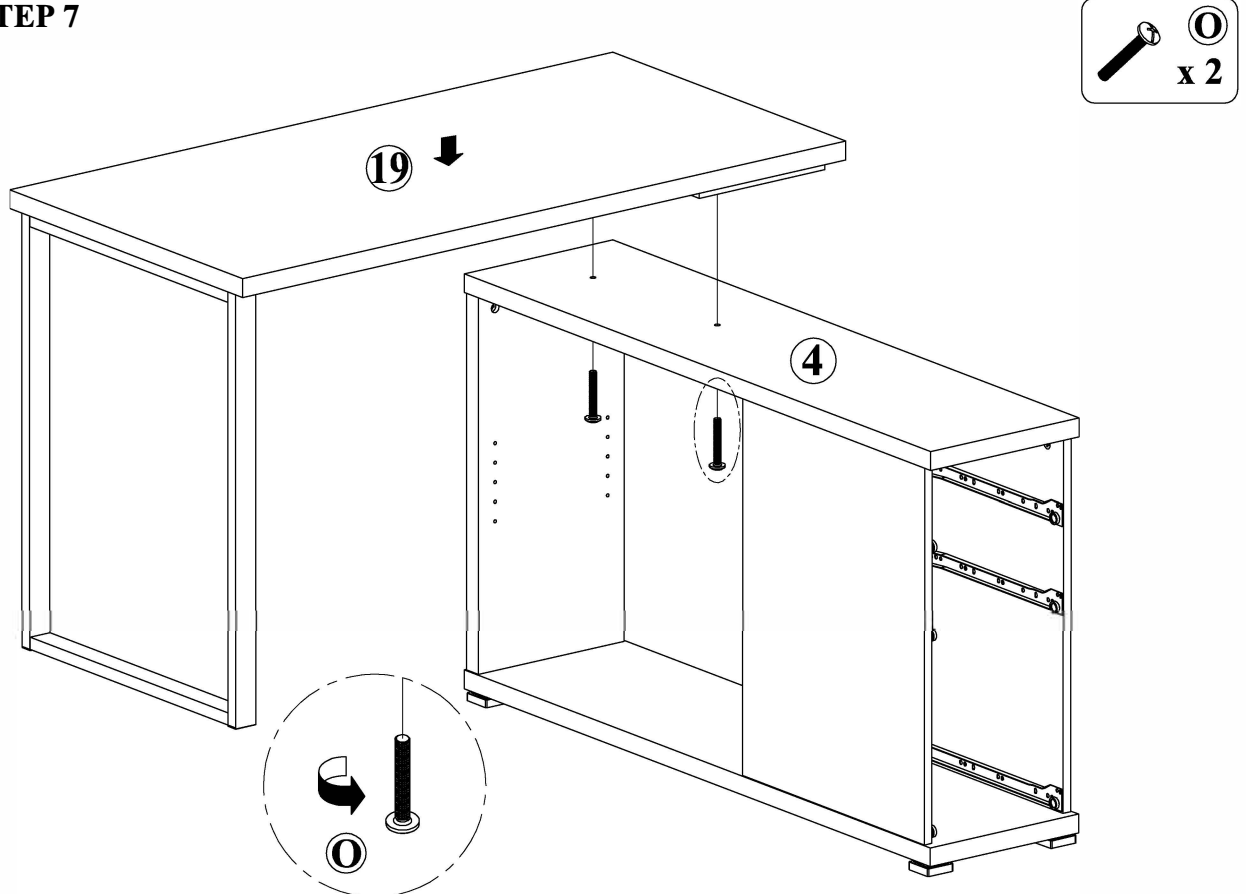

ÉTAPE / STEP 8-1

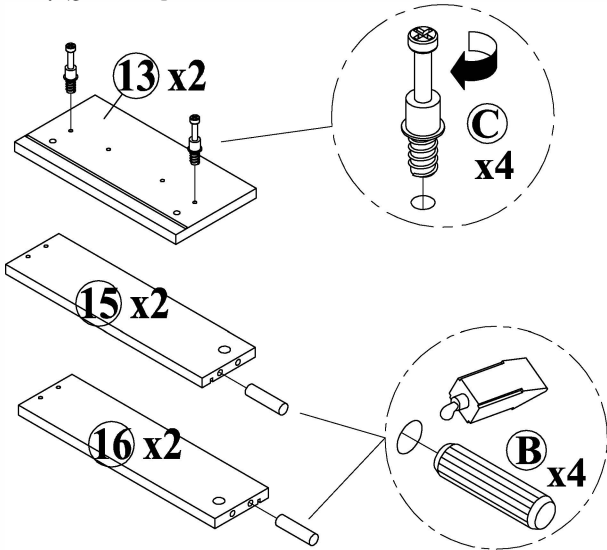

ÉTAPE / STEP 8-2

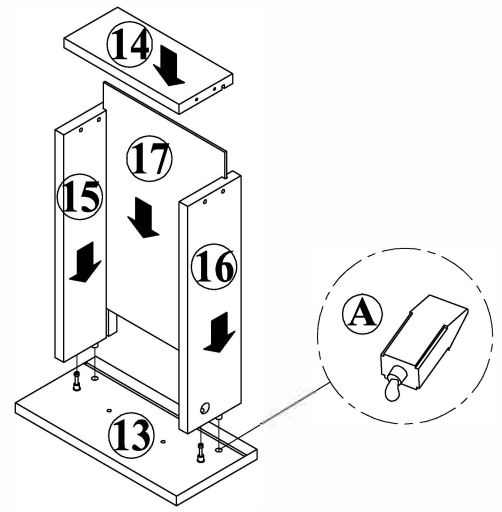

ÉTAPE / STEP 8-3

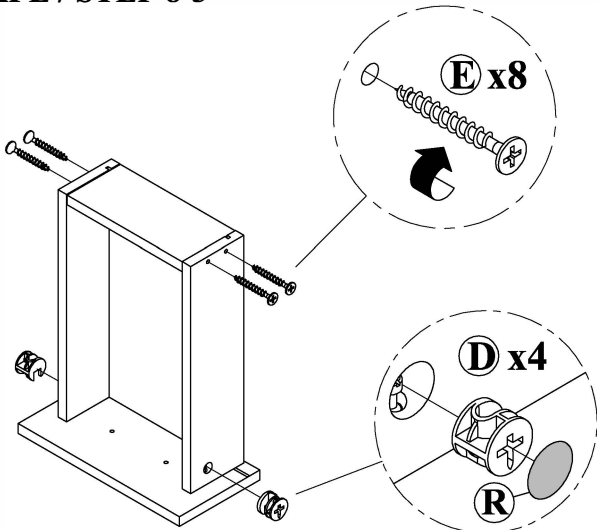

ÉTAPE / STEP 8-4

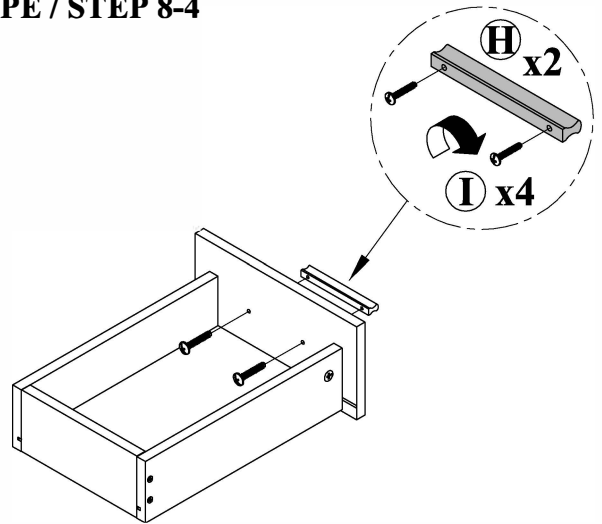

ÉTAPE / STEP 8-5

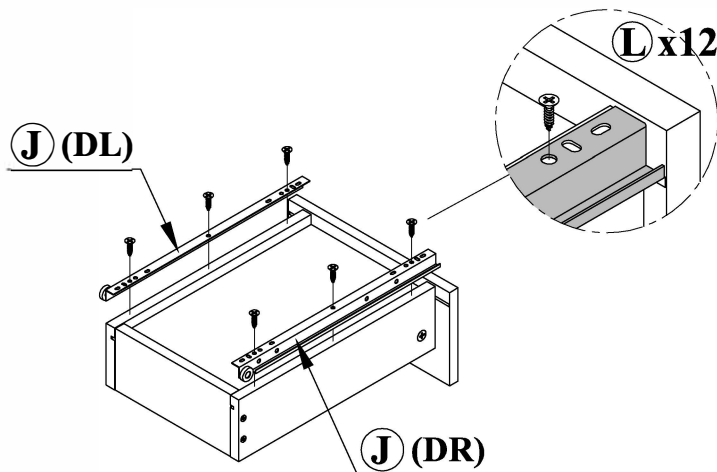

La colle (A) doit être utilisée aux endroits indiqués afin de solidifier l'étagère assemblée.  
The Glue (A) should be used in the indicated locations to help solidify the assembled unit.

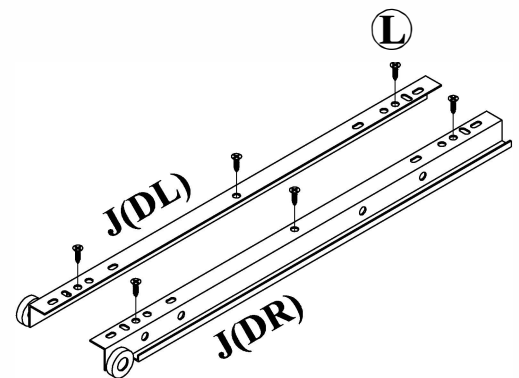

**ÉTAPE / STEP 9-1**

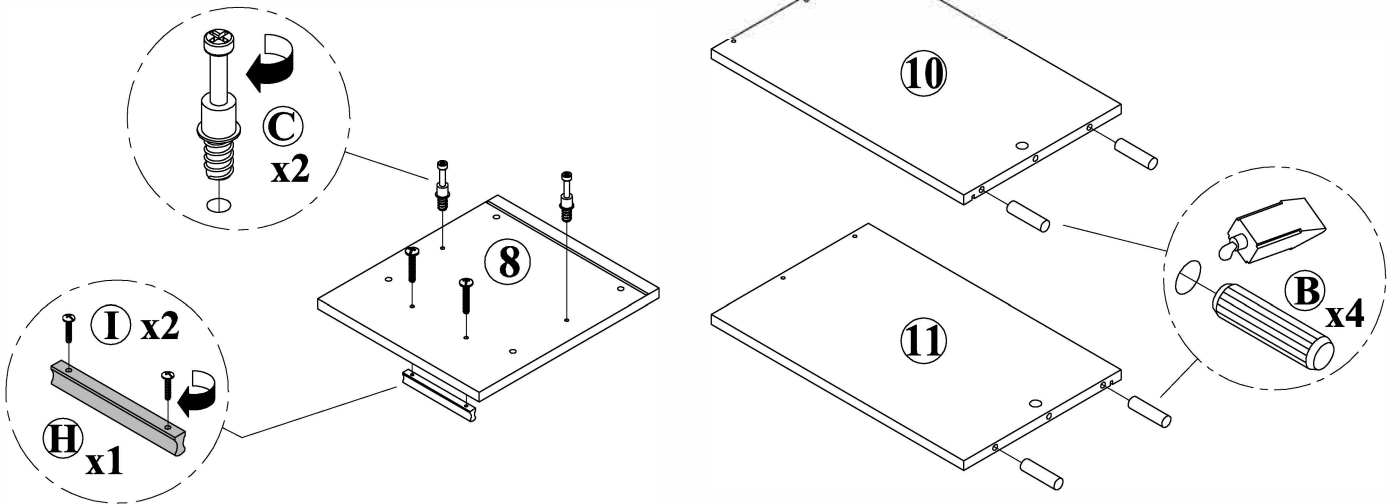

**ÉTAPE / STEP 9-2**

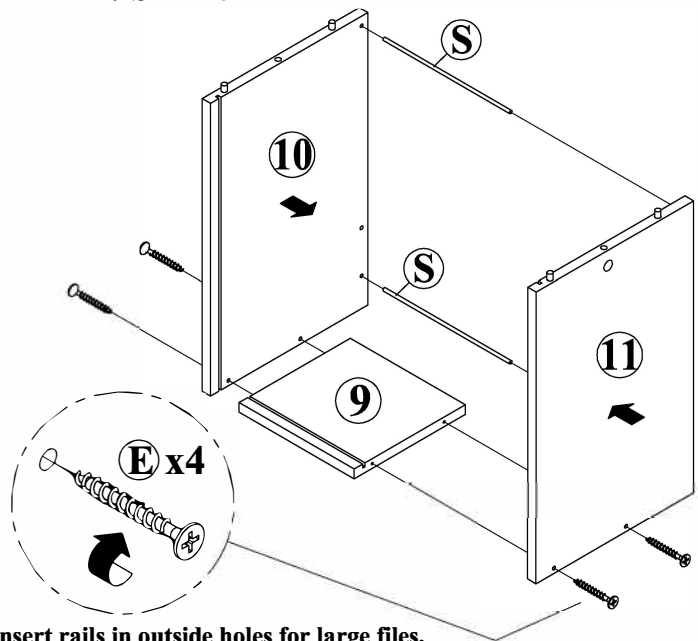

Insert rails in outside holes for large files.  
Insert rails in inside holes for small files.

**ÉTAPE / STEP 9-3**

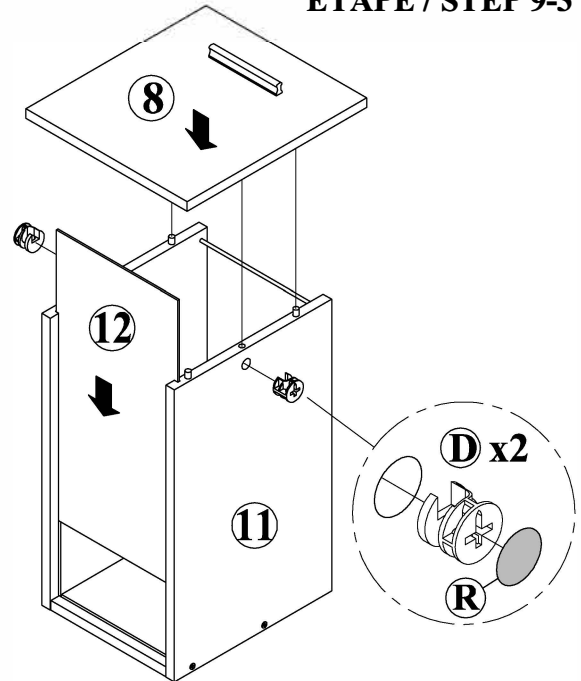

**ÉTAPE / STEP 9-4**

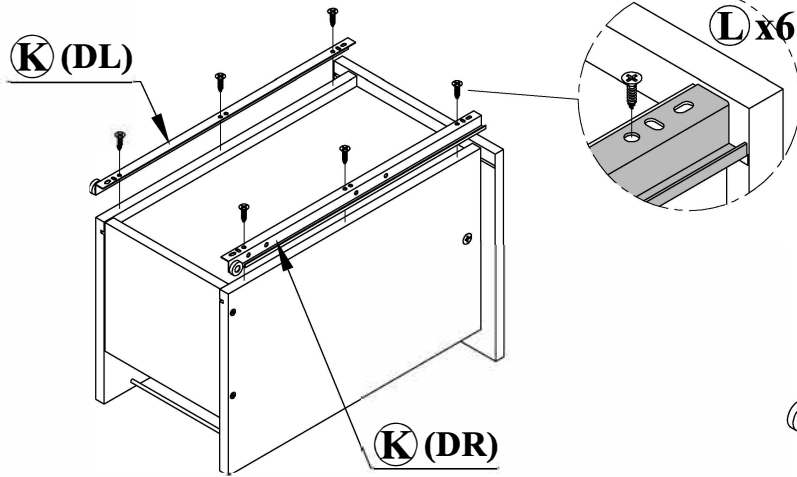

La colle (A) doit être utilisée aux endroits indiqués  
afin de solidifier l'étagère assemblée.  
The Glue (A) should be used in the indicated  
locations to help solidify the assembled unit.

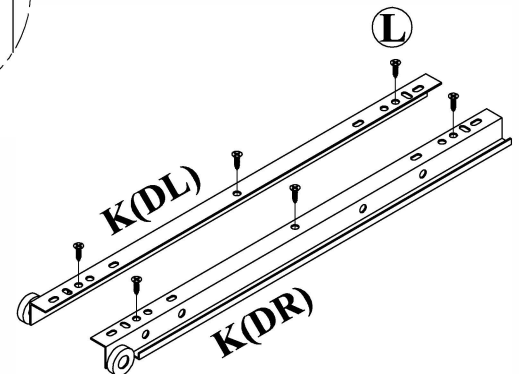

ÉTAPE / STEP 10

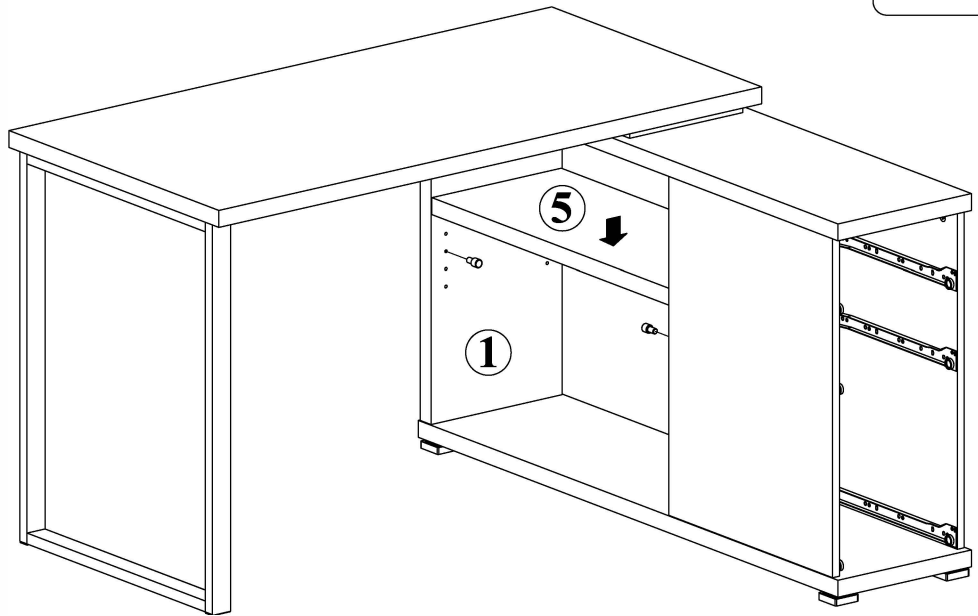
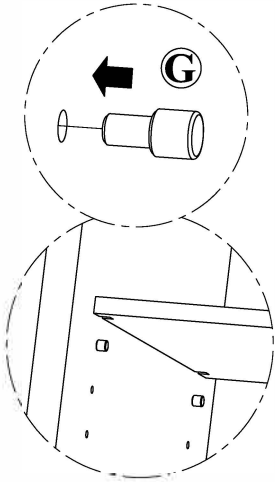
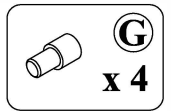

ÉTAPE / STEP 11

