

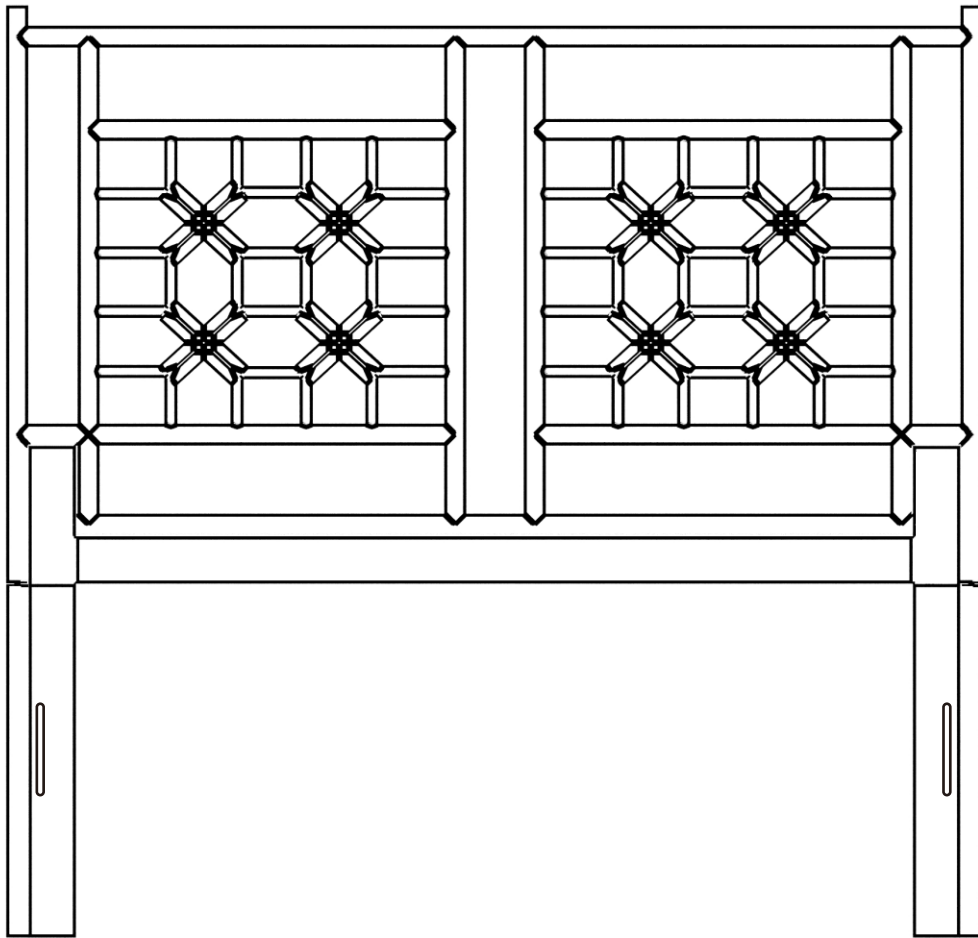

ASSEMBLY INSTRUCTIONS

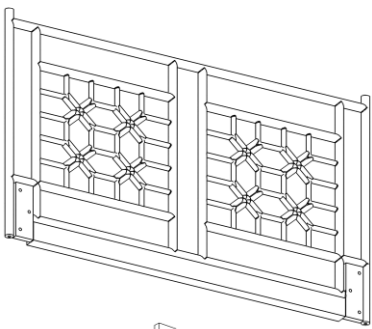



HEADBOARD FULL





PARTS IDENTIFICATION

A.		HEADBOARD TOP	1 PC
B.		RIGHT LEG	1 PC
C.		LEFT LEG	1 PC

HARDWARE IDENTIFICATION

1.		JCBC BOLT M8X40	6 PCS
2.		LOCK WASHER M8	6 PCS
3.		FLAT WASHER M8	6 PCS
4.		ALLEN WRENCH	1 PC

HARDWARE IDENTIFICATION
(FOR ADJUSTABLE BED FRAME ONLY)

5.		CB BOLT 1/4" X 3"	8 PCS
6.		HEX NUT M6	8 PCS
7.		FLAT WASHER M6 LBS	8 PCS

STEP 1.

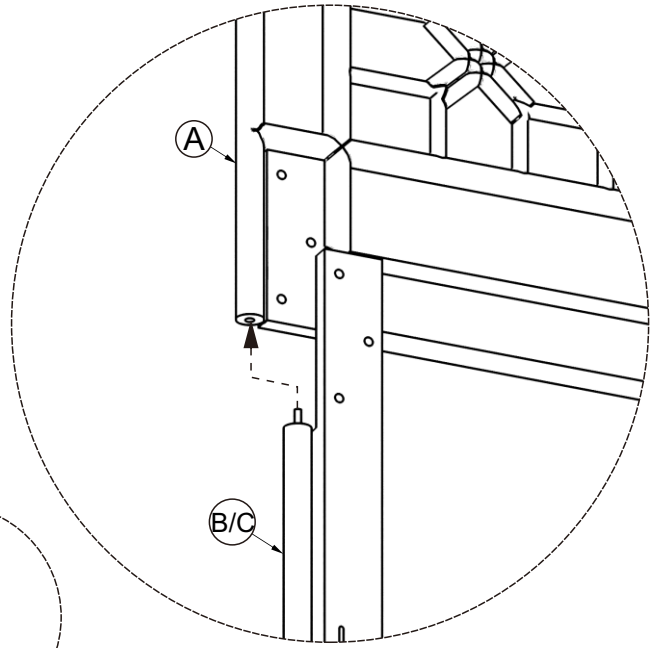
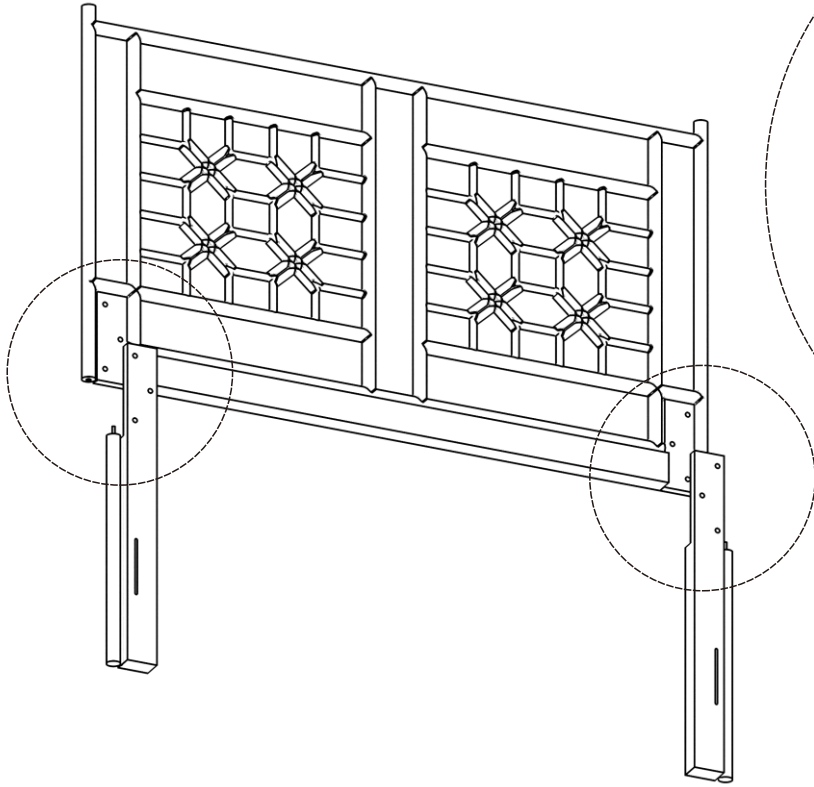

STEP 2.

