

ASSEMBLY INSTRUCTIONS



CAUTION

- ◆ Inspect the wire insulation for any cuts, abrasions, or exposed copper that may have resulted during shipping. If there is a defect in the wire, do not attempt installation.
- ◆ Before starting installation of this fixture or removal of a previous fixture, disconnect the power by turning off the circuit breaker or by removing the fuse at the fuse box.

TOOLS REQUIRED



Ladder



**Safety
glasses**



**Phillips
screwdriver**

PARTS SHOWN MAY DIFFER SLIGHTLY PER LIGHT FIXTURE

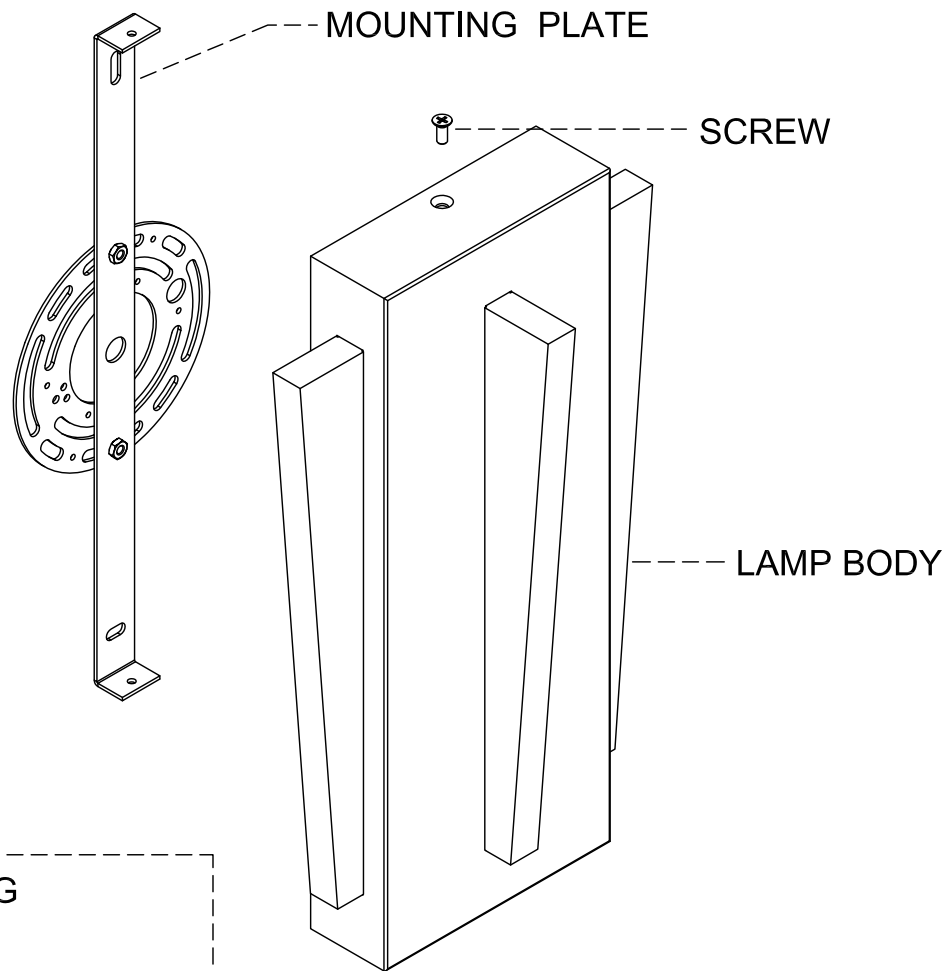

PART BAG

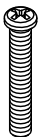

X2



X2

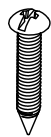

X2



X3

Step 1
Power off

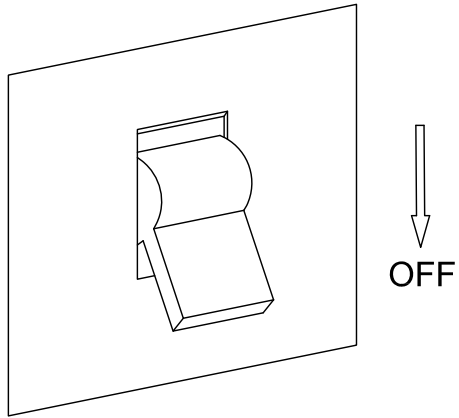

Step 2
Use the mounting screws to attach the mounting strip to the junction box(not included).

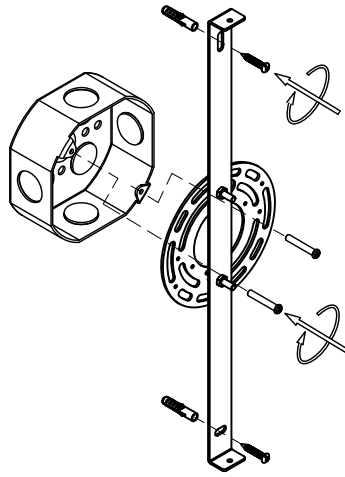

Step 3
Connect the wire.

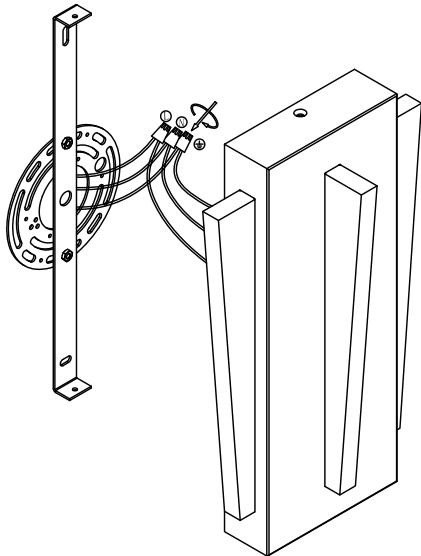

Step 4
Attach the sconce to the mounting strip.

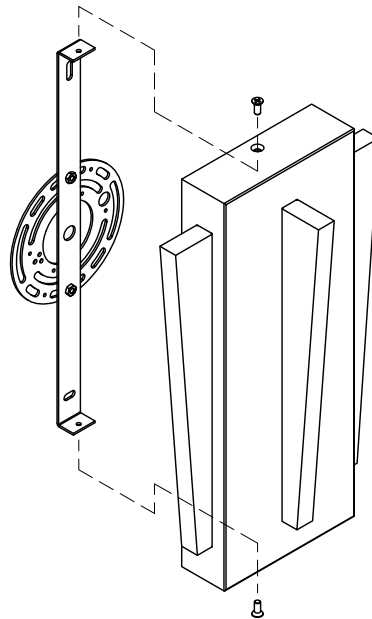

SCONCE

