

Assembly Instruction

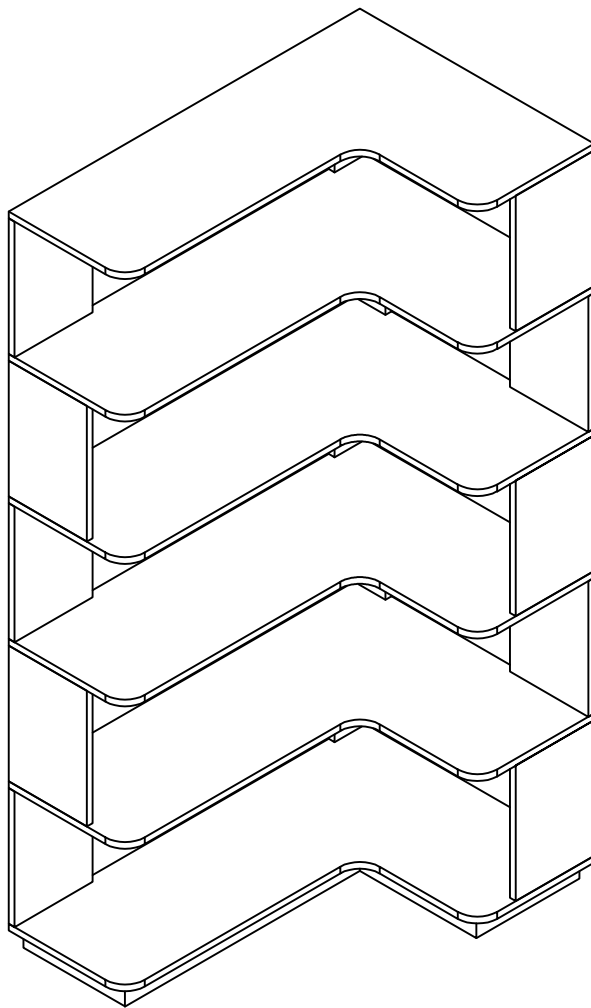

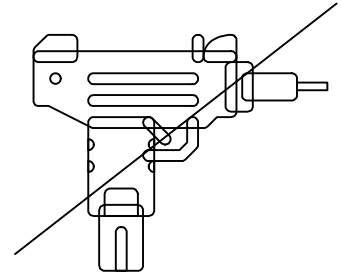
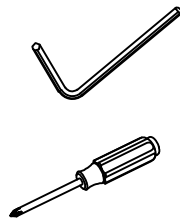
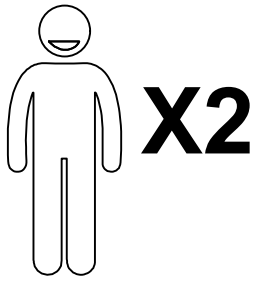

We recommend using hand tools for assembly.

If an electric screwdriver is used, reduce power and torque to avoid damage to the product.

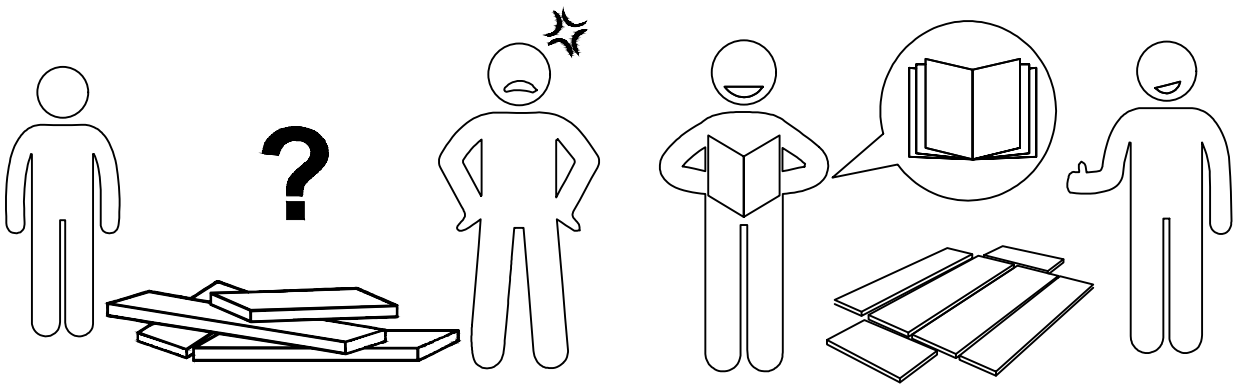

Install the Anti-Tip Straps

Using the anti-tip straps can reduce the risk of tipping over but can not eliminate it.

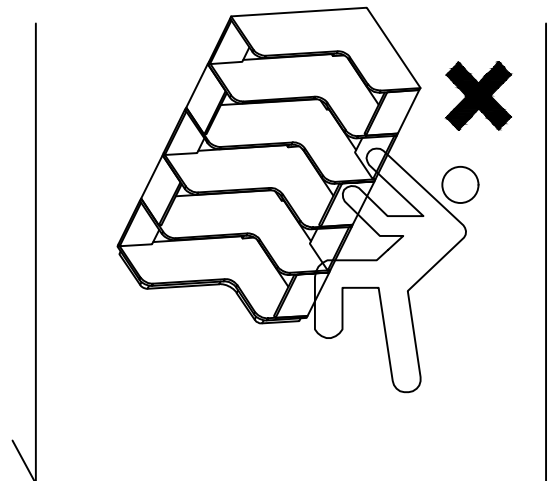
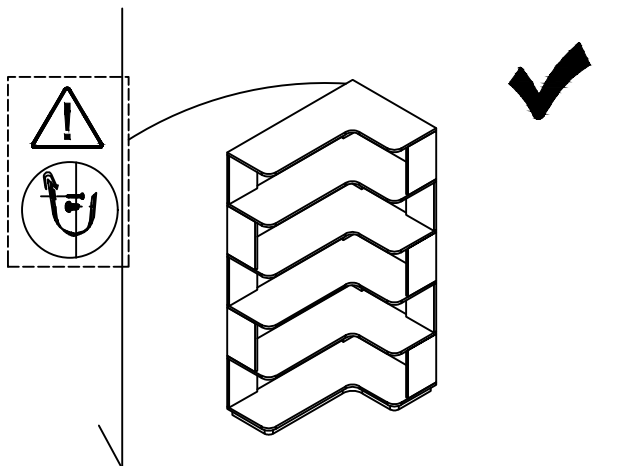

Installation of Cams and Pins

Screw the pin into the hole. To set the cams correctly, ensure that the arrow on the cam is opening to the hole of the pin it is locking. Lock the cam by turning the cam head with a screwdriver until it is tightened. Please do not use an electric screwdriver to assemble the unit.

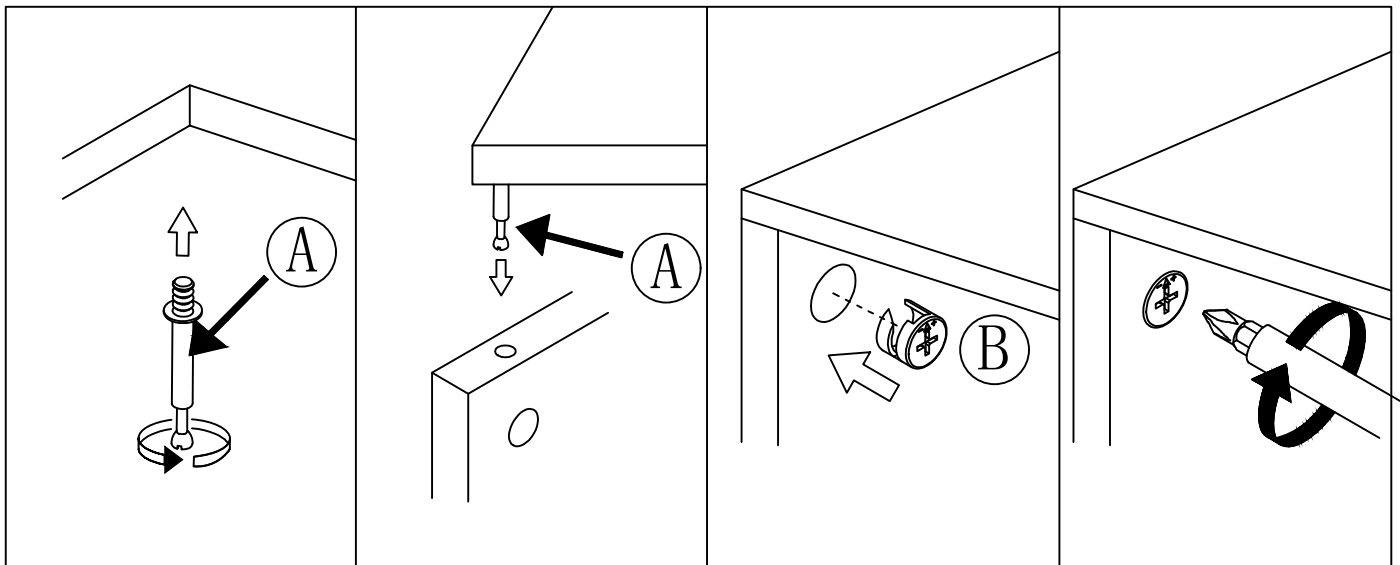

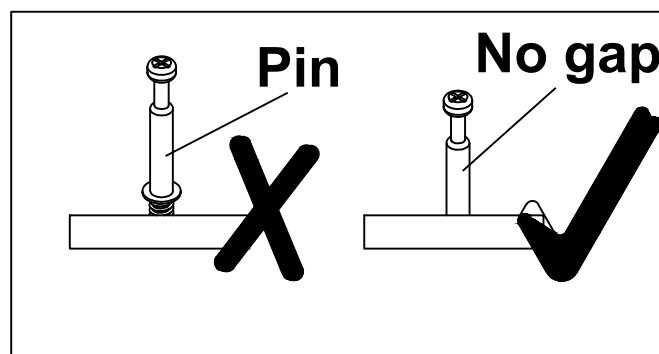

Read each step carefully before starting. It is very important that each step of instruction is performed in the correct order. If these steps are not followed in sequence, assembly difficulties will occur.



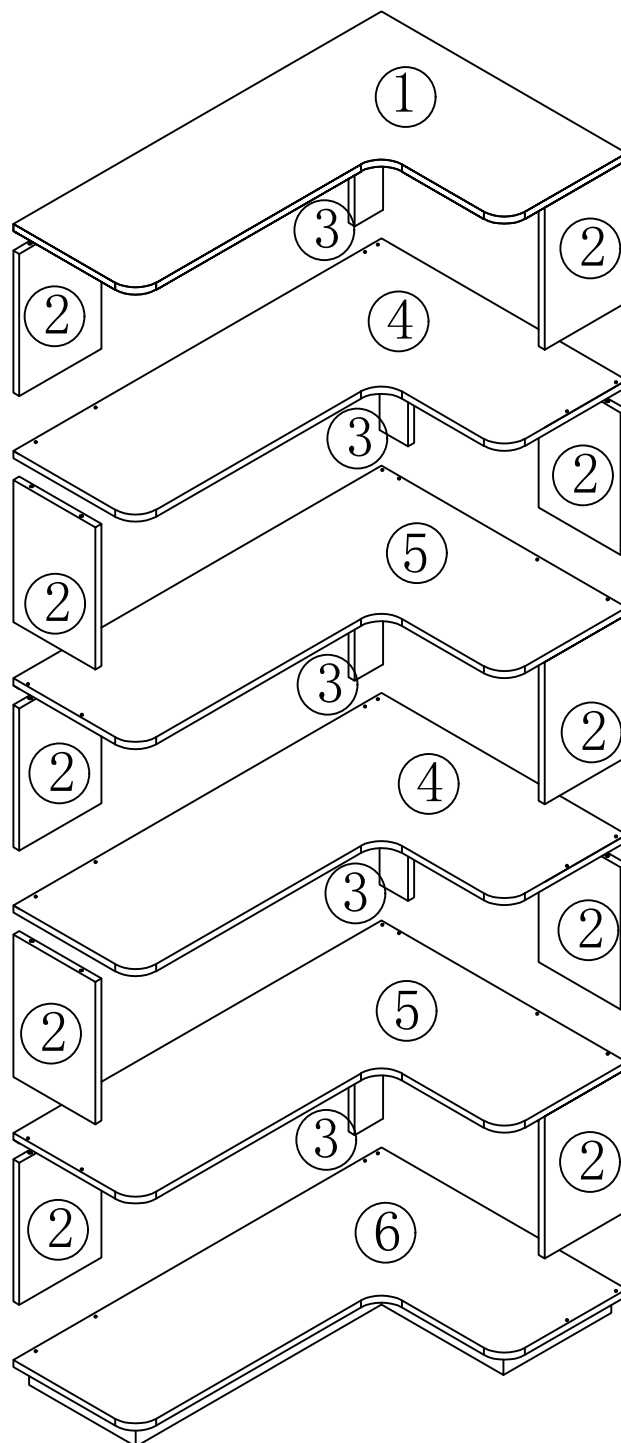

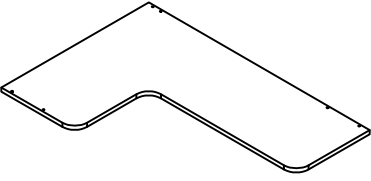
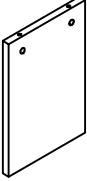

ASSEMBLY INSTRUCTION

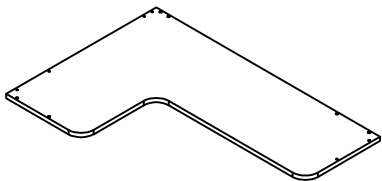
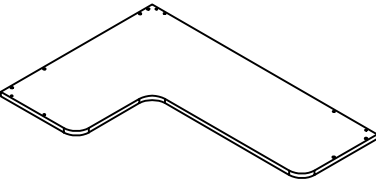
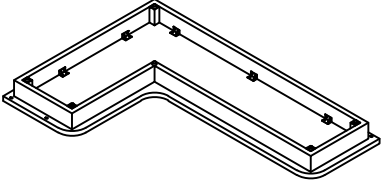



Part List

 <p>① 1pc</p>	 <p>② 10pcs</p>	 <p>③ 5pcs</p>	 <p>④ 2pcs</p>
 <p>⑤ 2pcs</p>	 <p>⑥ 1pc</p>		

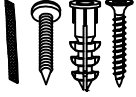
Hardware List



 <p>Ø6x32mm 30+2spare</p> <p>A</p>	 <p>Ø15x10mm 30+2spare</p> <p>B</p>	 <p>M6x50mm 30+2spare</p> <p>C</p>
 <p>1pc</p> <p>D</p>	 <p>Ø20mm 30+2spare</p> <p>E</p>	 <p>2sets</p> <p>F</p>

STEP 1

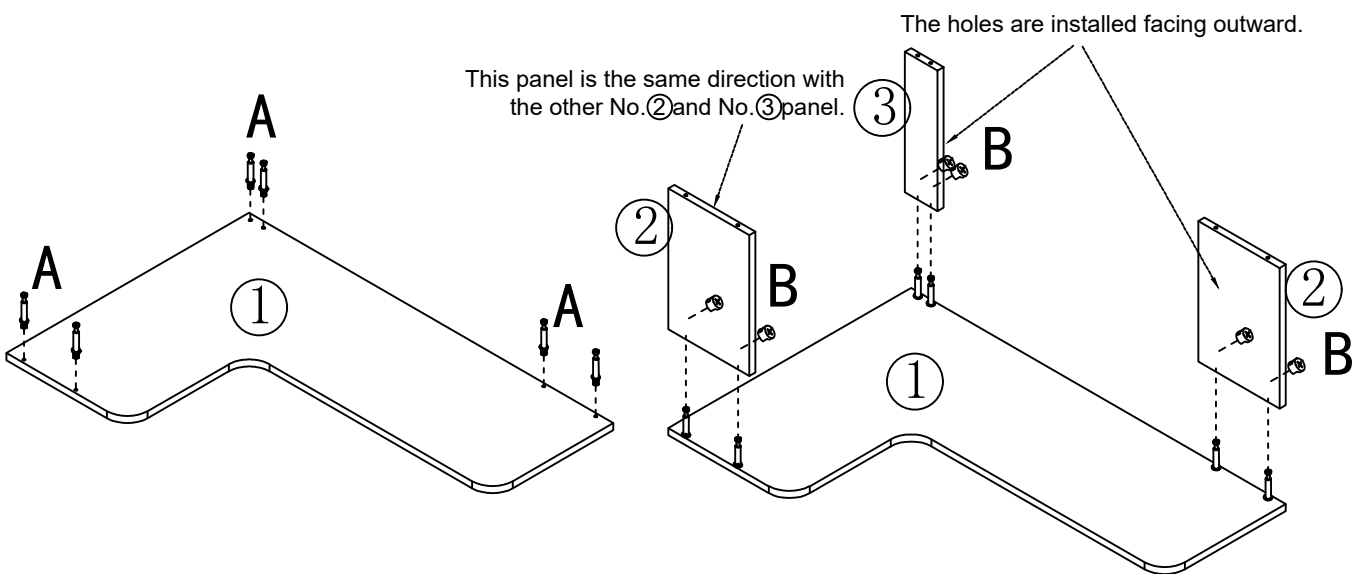
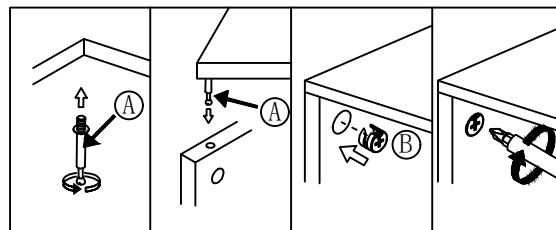
A:		6PCS
B:		6PCS



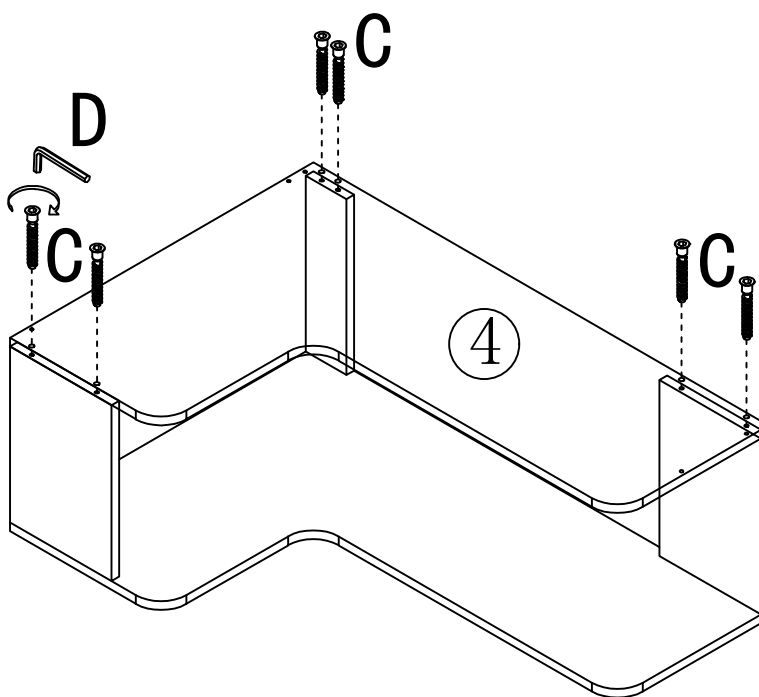

STEP 2

C:		6PCS
D:		1PC



STEP 3

A:		6PCS
B:		6PCS

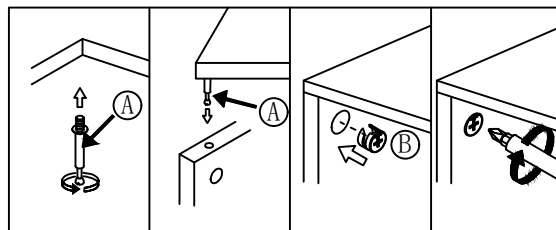

The holes are installed facing outward.

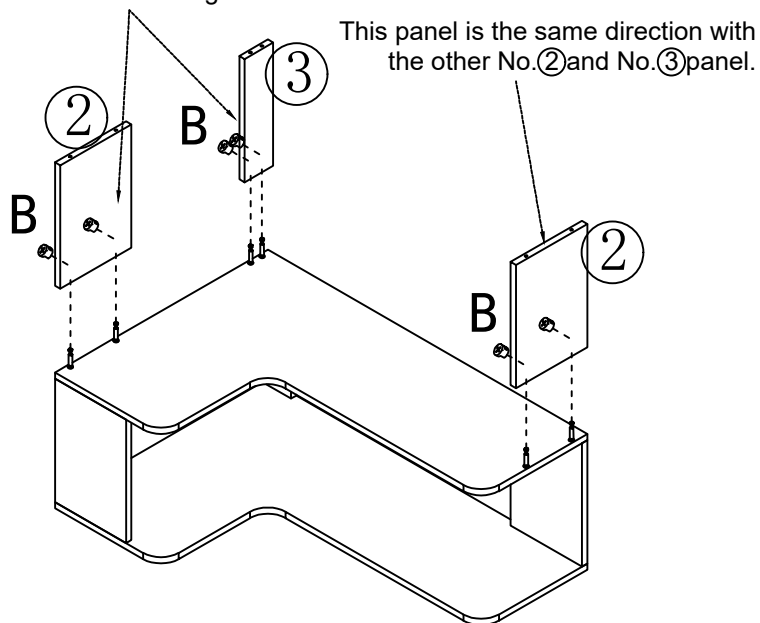
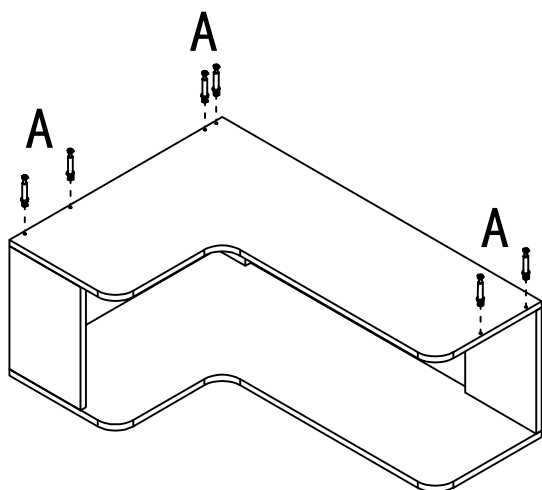

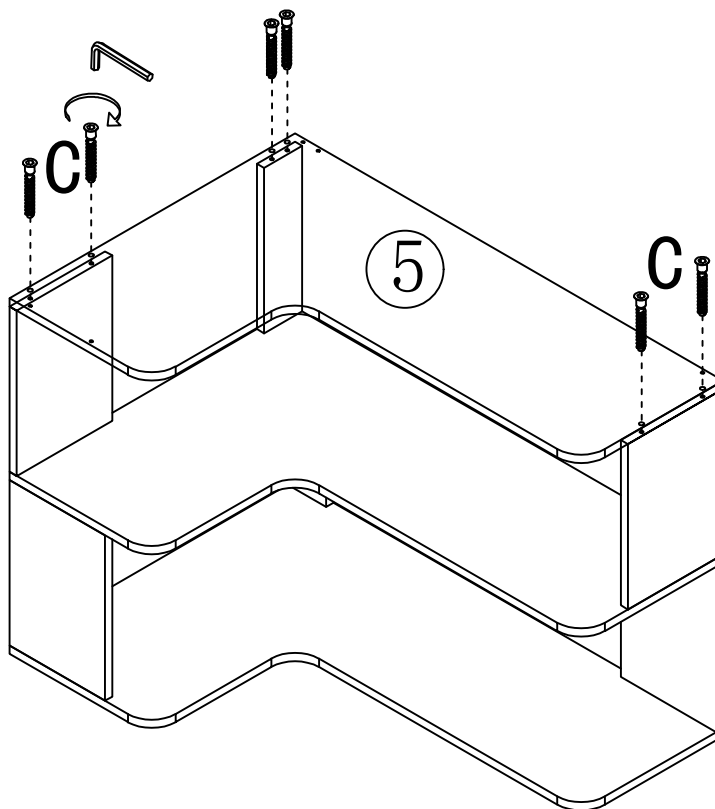

STEP 4

C:		6PCS
----	---	------



STEP 5

A:		6PCS
B:		6PCS

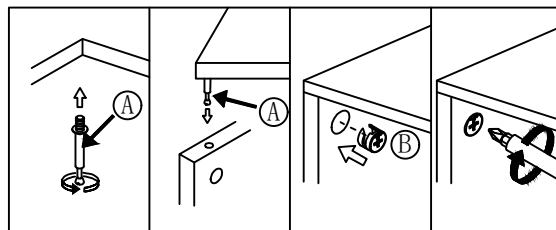

This panel is the same direction with the other No.② and No.③ panel.

The holes are installed facing outward.

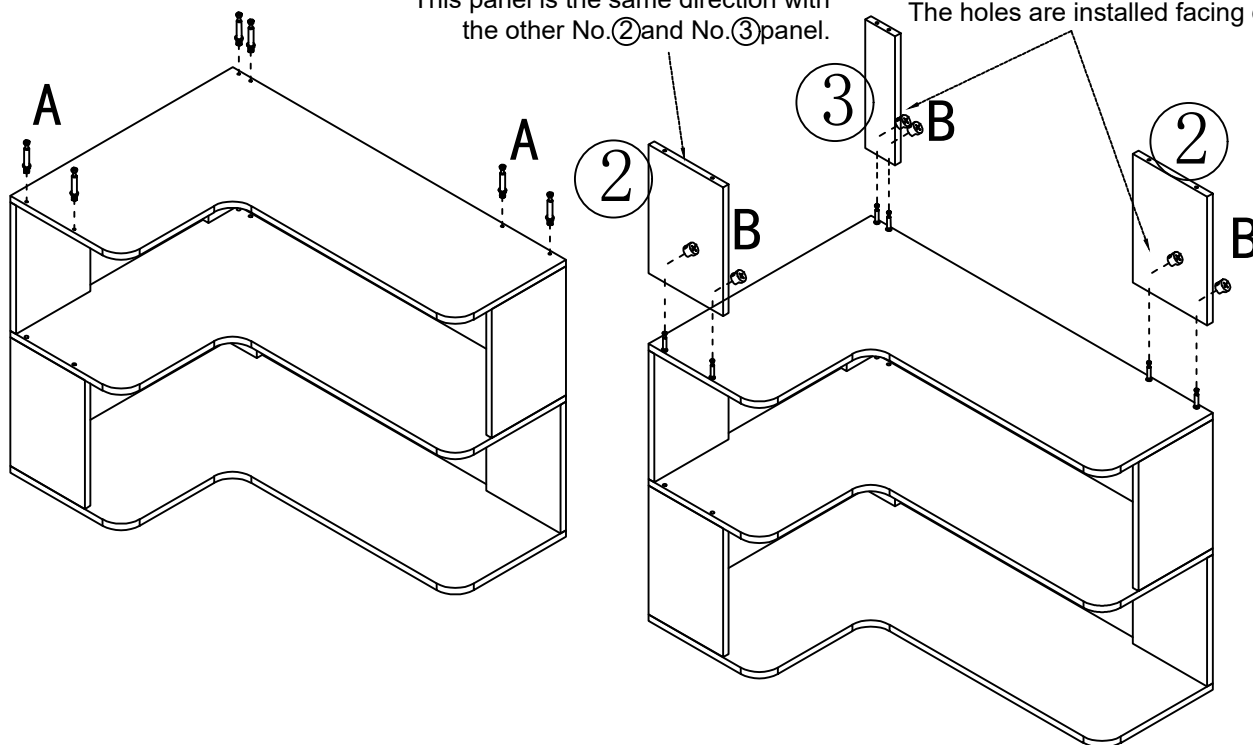

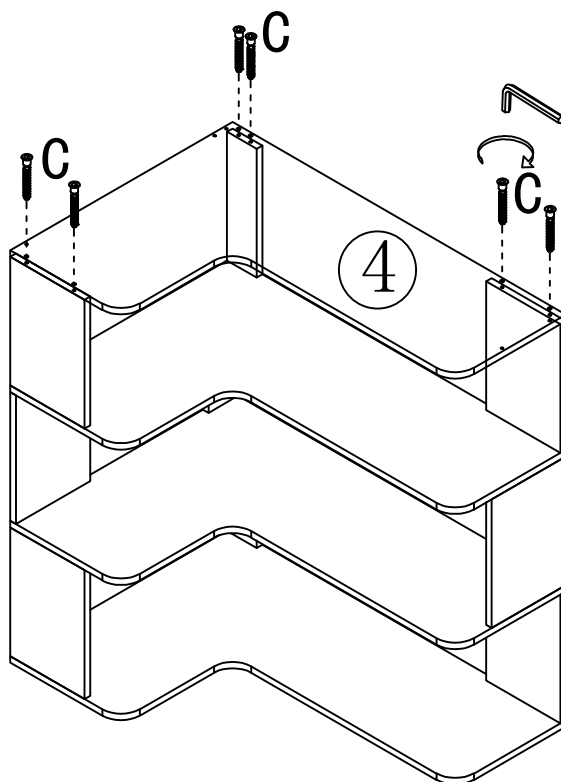

STEP 6

C:		6PCS
----	---	------



STEP 7

A:		6PCS
B:		6PCS

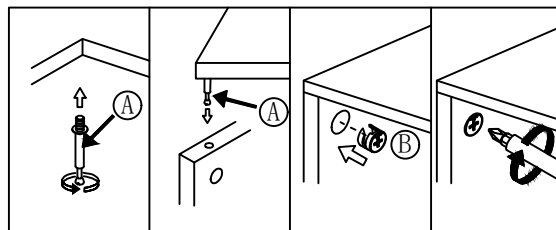

The holes are installed facing outward.

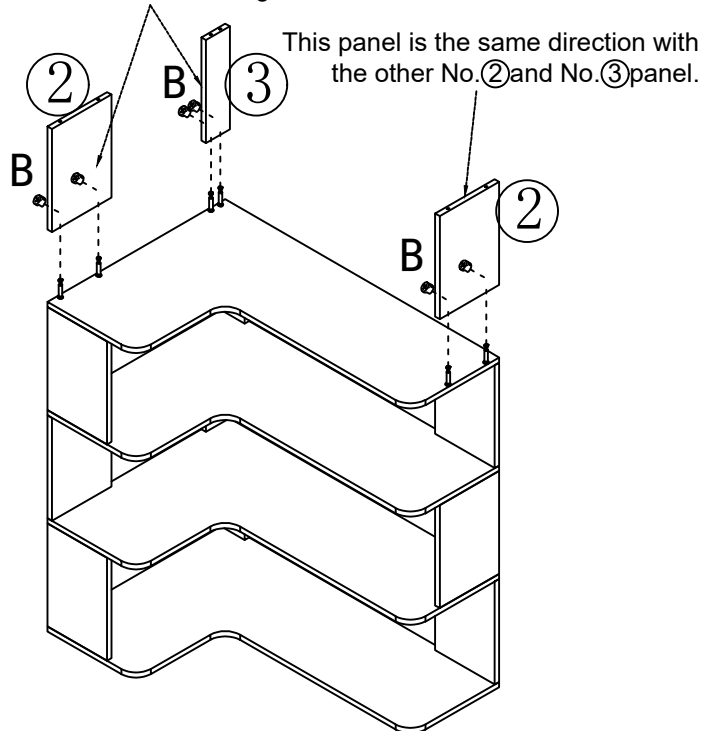
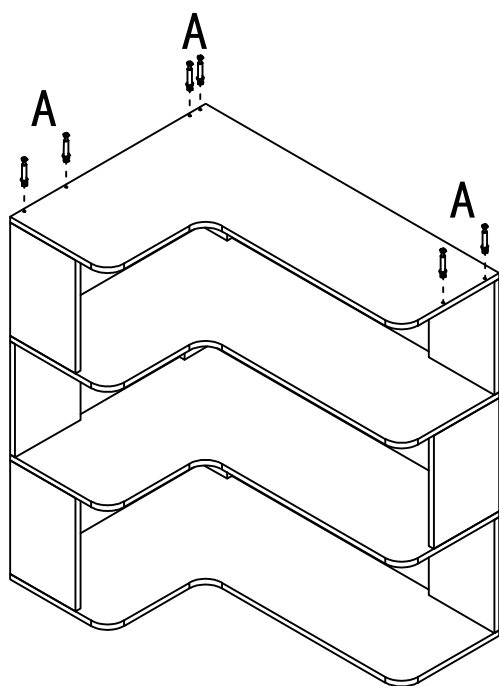

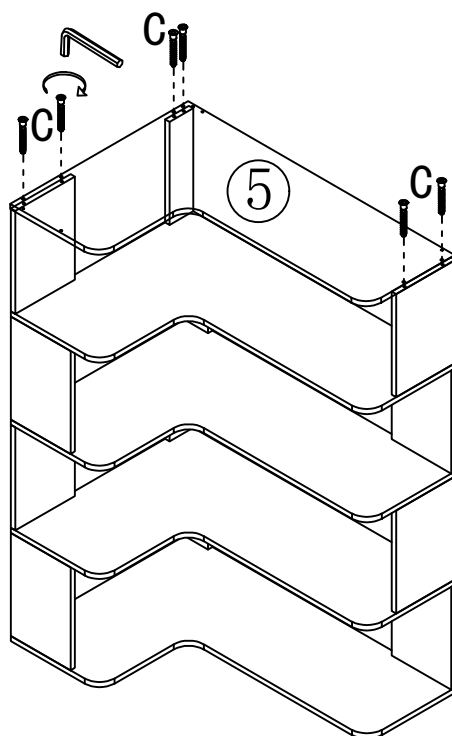

STEP 8

C:		6PCS
----	---	------



STEP 9

A:		6PCS
B:		6PCS

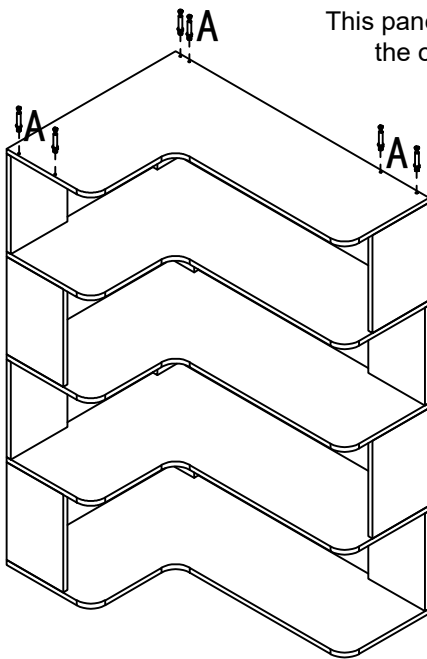
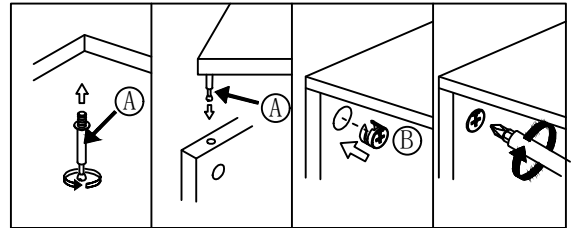

This panel is the same direction with the other No.②and No.③panel.

The holes are installed facing outward.

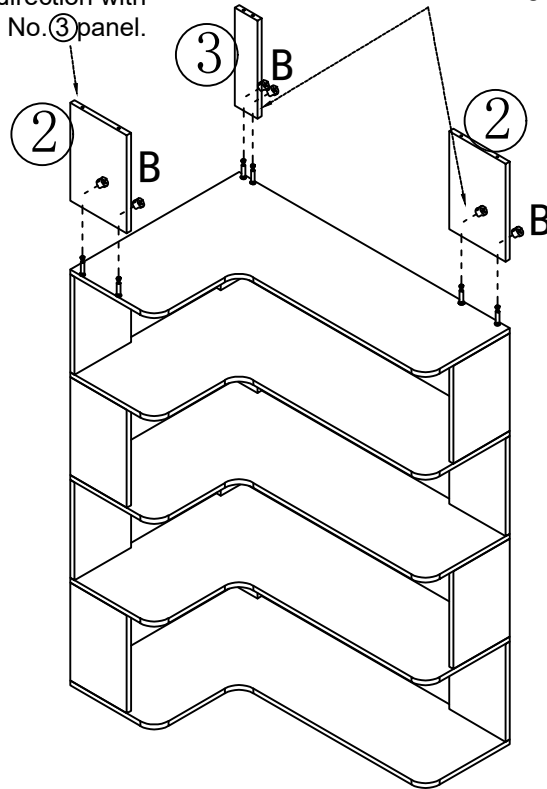

STEP 10

C:		6PCS
----	---	------

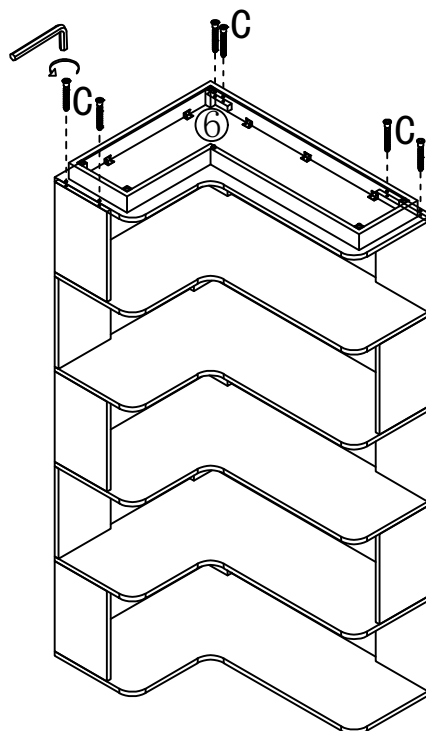

STEP 11

E: ○ 30PCS

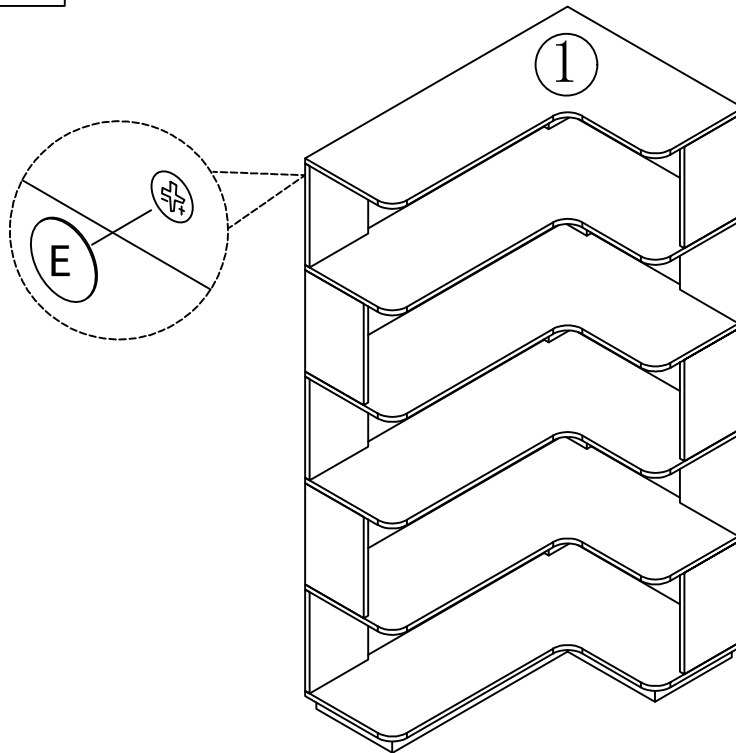

STEP 12

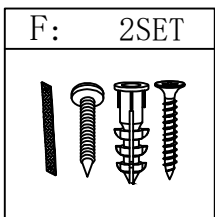

If it is a solid wall, please use expansion and self-tapping screws, if it is a wooden wall, only use self-tapping screws, please do not overtighten the screws

