

WICHTIG - FÜR SPÄTERE VERWENDUNG
AUFBEWAHREN - SORGFÄLTIG LESEN

AVIS - Ces instructions doivent être sauvegardées
Pour utilisation future - Les instructions doivent
être suivies

IMPORTANTE, conservar estas instrucciones
para futuro uso. Siga estas instrucciones atentamente

VIGTIGT - Samlevejledningen skal opbevares
i arkiv til senere brug - Skal gennemlæses nøje

NOTICE - These instructions must be saved
for future use - Instructions must be followed

TEILCHECKLISTE
 LISTE DE CONTROLE
 LISTADO DE CONTROL
 TJEKLISTE
 CHECK LIST



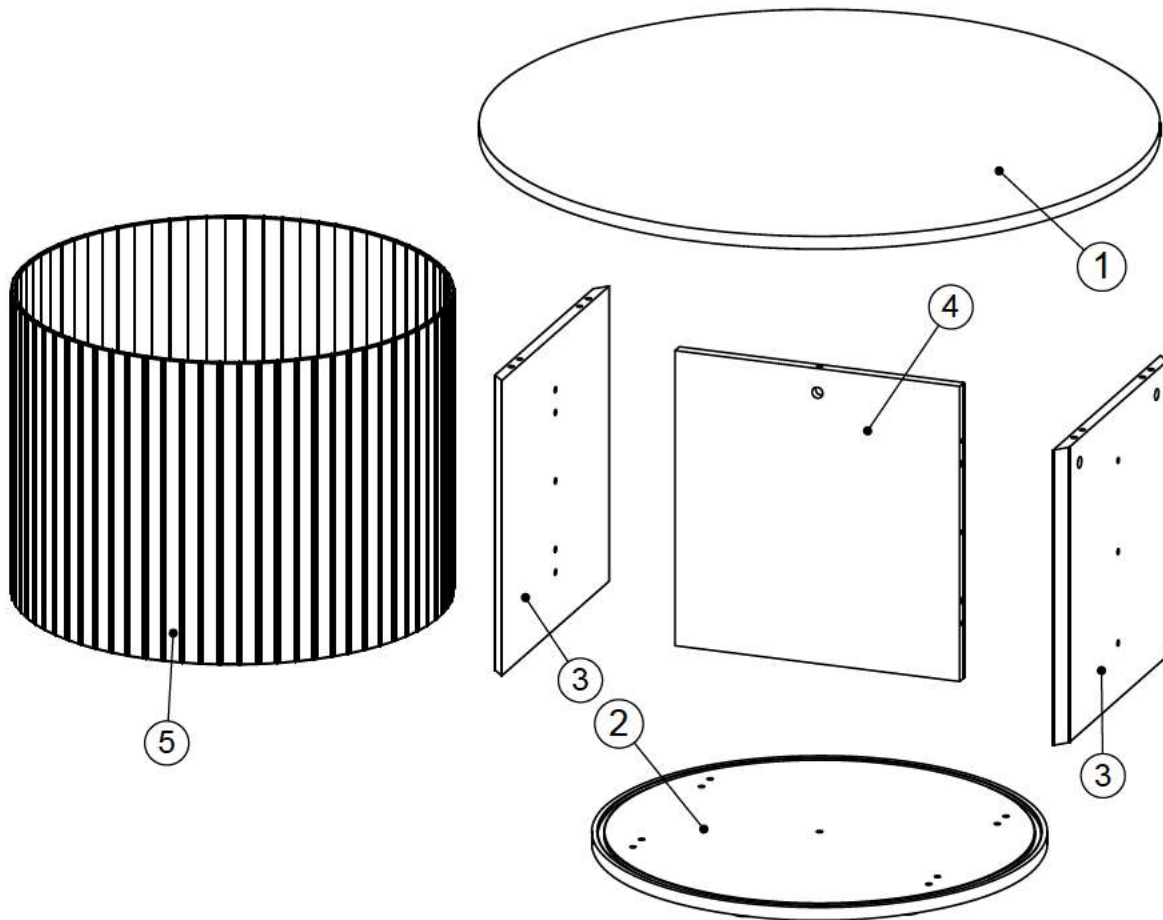

Réf./No.	Réf./Art	Qty./Stck./Quantité	Size / Maß / Dimension (mm)	Qty./Stck./Quantité	✓
1	328685464	1	Φ35.4"x0.7"		
2	328686464	1	Φ23.6"x0.7"		
3	328687464	2	16.3"x15.8"x0.6"		
4	328688464	1	16.3"x15.8"x0.6"		
5	328689464	1	Φ23.1"x16.7"		

Réf./No.	Réf./Art	Qty./Stck./Quantité	Size / Maß / Dimension (mm)	Qty./Stck./Quantité	✓
1	328685293	1	Φ35.4"x0.7"		
2	328686293	1	Φ23.6"x0.7"		
3	328687293	2	16.3"x15.8"x0.6"		
4	328688293	1	16.3"x15.8"x0.6"		
5	328689293	1	Φ23.1"x16.7"		

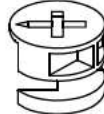

TEILCHECKLISTE - LISTE DE CONTROLE - LISTADO DE CONTROL- TJEKLISTE - CHECK LIST

Réf./No.	Réf./Art.	Qty./Stck./Quantité	✓
A	228690	12	
B	228690	5	
C	228690	5	
E	228690	11	
F	228690	1	

12 - A	5 - B	5 - C	11 - E	1 - F	
 $\varnothing 5/16" \times 1.2"$	 $\varnothing 3/8" \times 1.7"$	 $\varnothing 19/32" \times 14/32"$	 $\varnothing 9/32" \times 2"$	 $5/32"$	

Geehrter Kunde.
 Hier haben Sie die Möglichkeit die mitgelieferten
 Schrauben nachzumessen.

Cher Client.
 La règle ci jointe vous permet de mesurer la visserie.

Estimado cliente.
 aquí podrá medir la tornillería adjunta.

Kære kunde.
 Her har De muligheden for at måle medsendte beslag.

Dear Customer.
 Below you have the opportunity to measure the
 Enclosed Hardware.

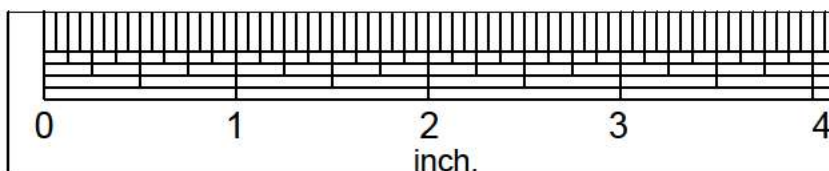

1 12 - A  

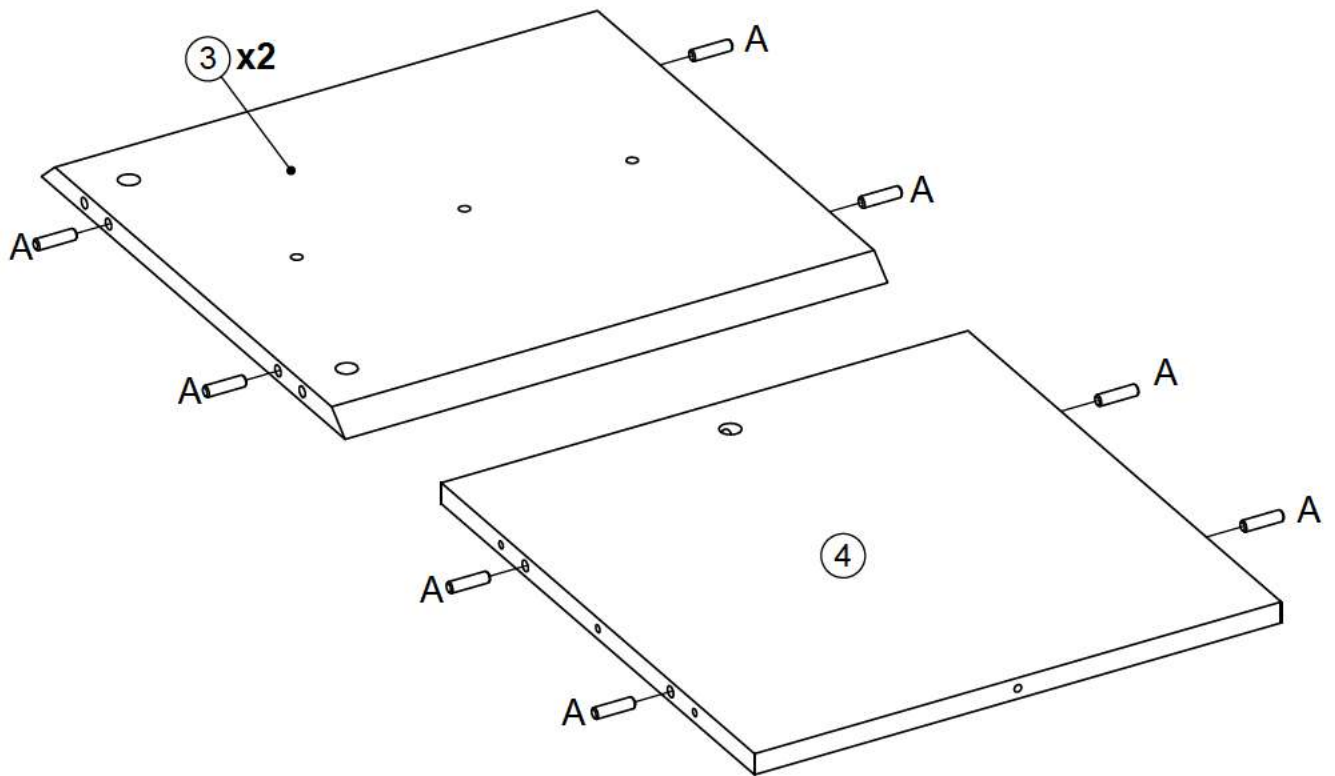

2 6 - E   1 - F

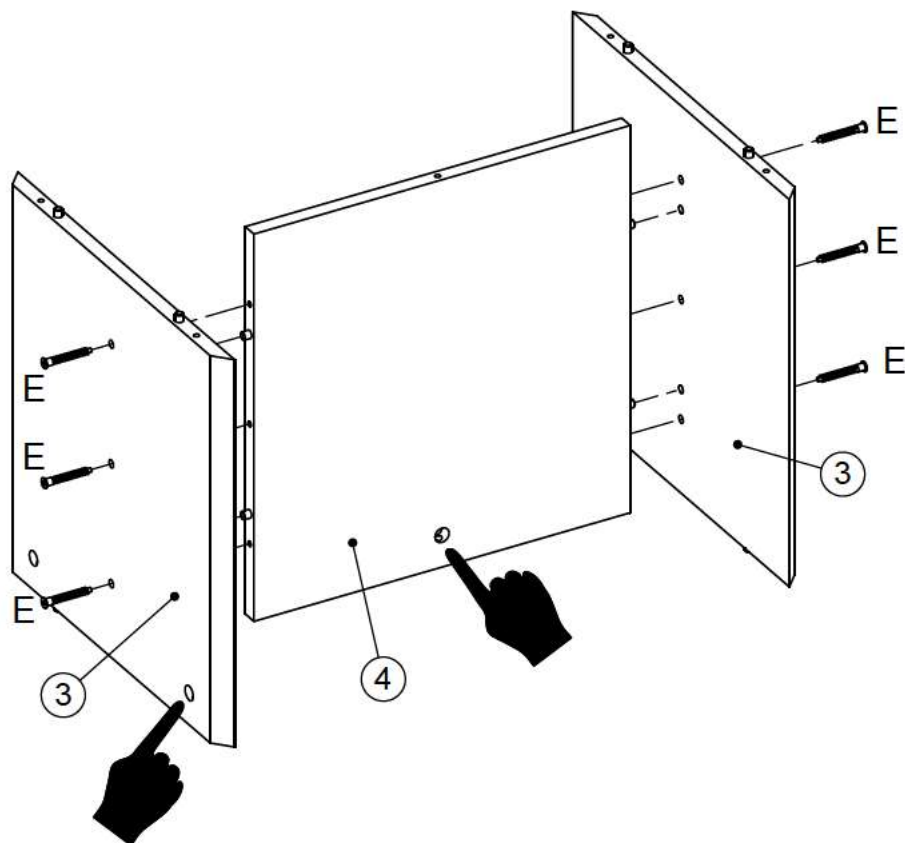

3 5 - B 

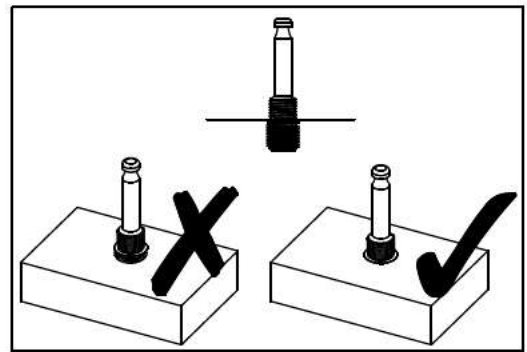
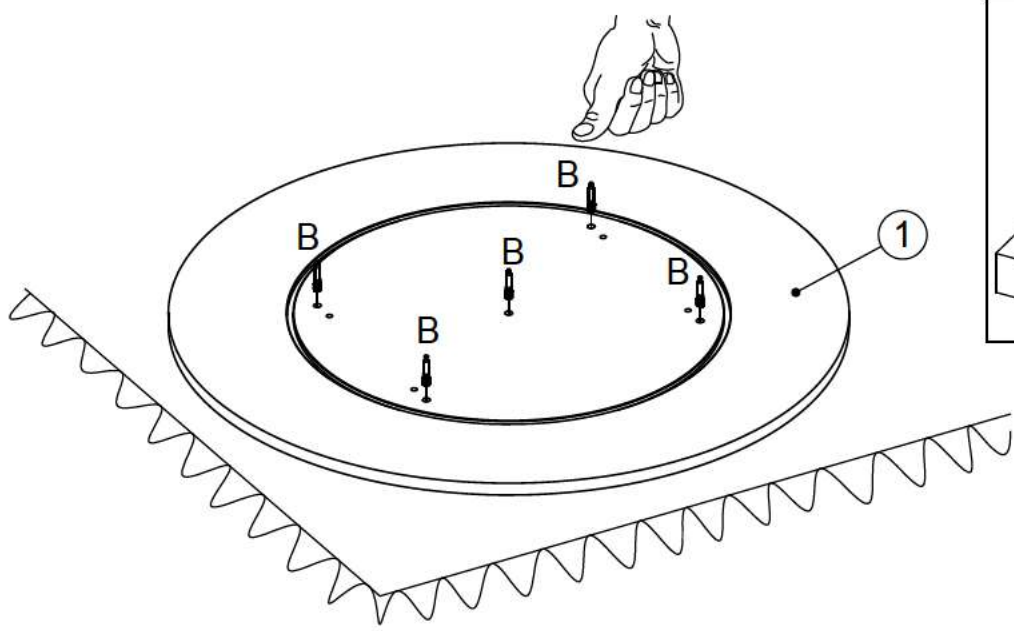

4 5 - C  

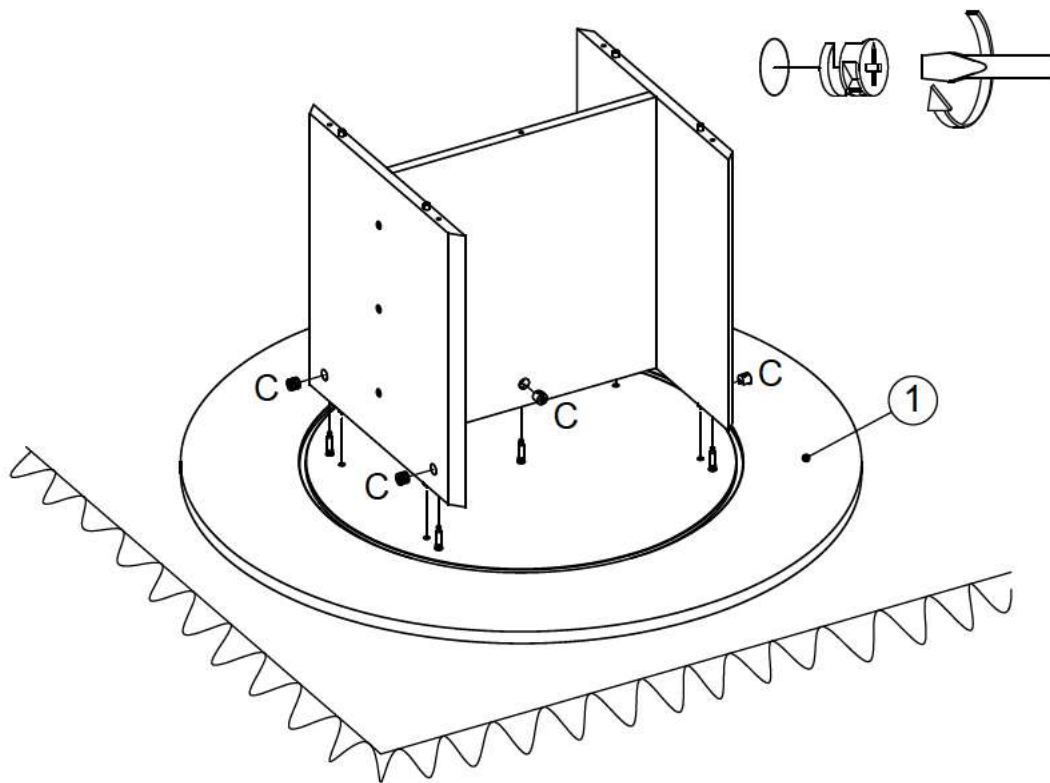

5

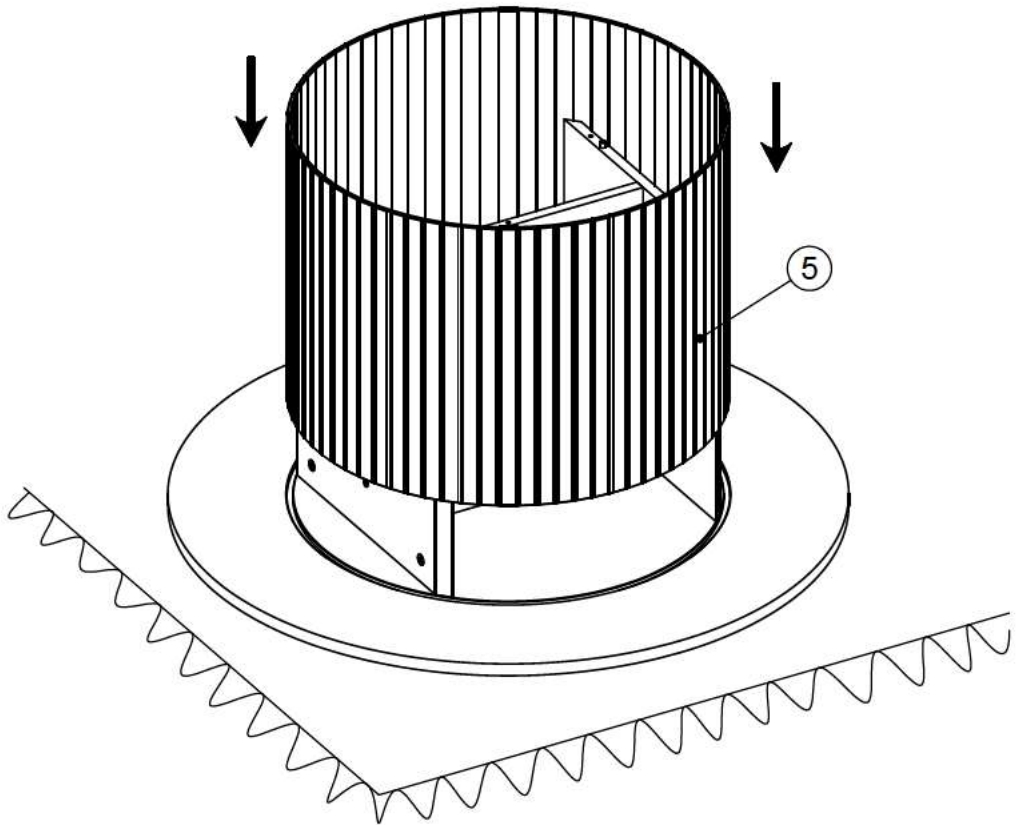

6

5 - E

1 - F

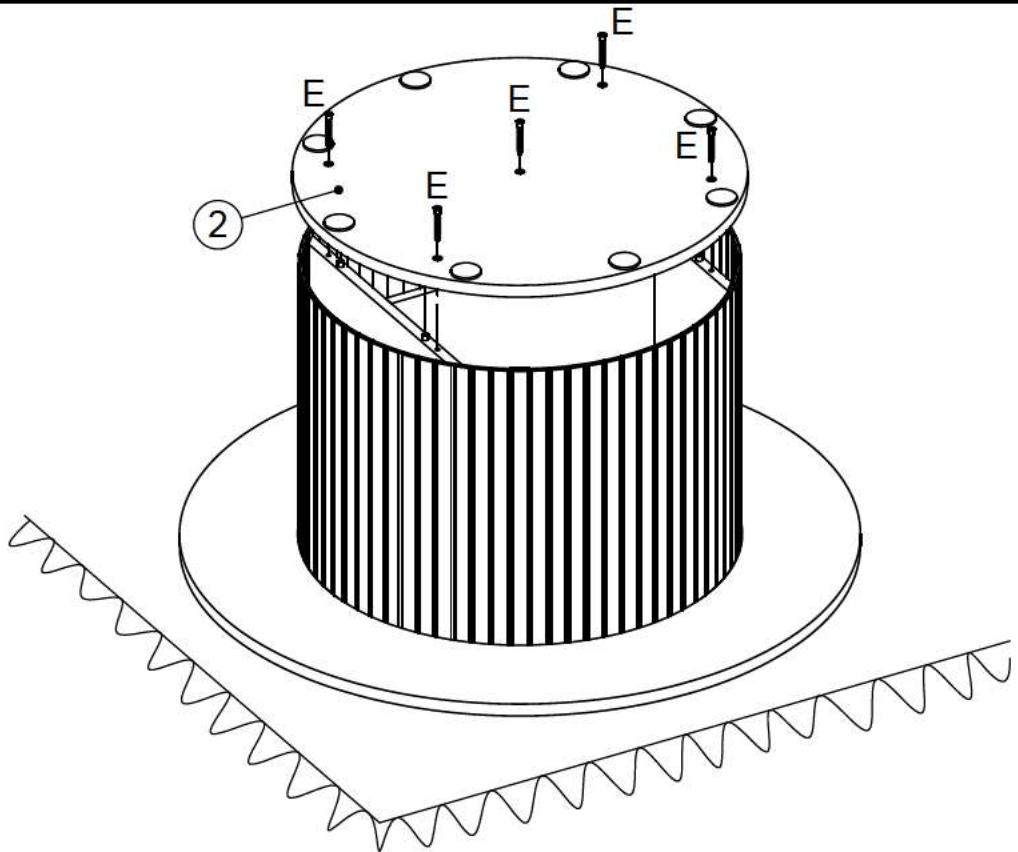
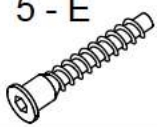

7

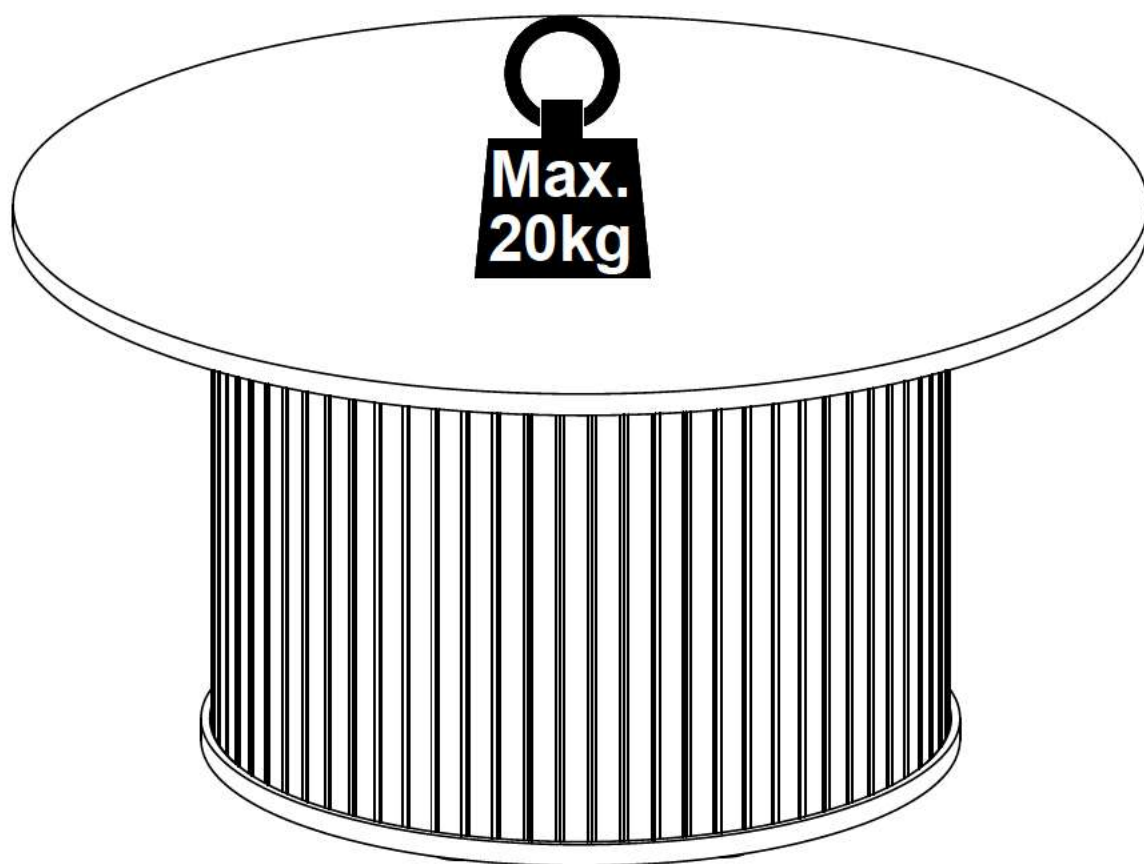



UK:

Always ensure the feet / felt pads provided with this product are suitable for your flooring.
Periodically check the position of any foot caps/felt pads used to ensure your floors are protected.

DE:

Wichtig : Bitte stellen Sie immer sicher , dass die mit diesem Produkt gelieferten Füße für Ihren Bodenbelag geeignet sind !
Bitte überprüfen Sie regelmäßig die Position der verwendeten Fußkappen oder Filzgleiter um sicherzustellen dass Ihre Böden geschützt sind !

ES:

Asegúrese siempre que los tapones de las patas de este producto son compatibles con su suelo.
Periódicamente revise que sus tapones y sus almohadillas de fieltro están correctamente colocadas para asegurar que su suelo esté protegido.

FR:

Assurez-vous toujours que les pieds/ patins fournis avec le produit sont compatibles avec le sol.
Contrôlez régulièrement la position des patins utilisés pour que vos sols soient protégés.

DK:

Sørg altid for at beskyttelse fødder / filt puderne der følger med dette produkt, passer til Deres gulv.
Kontroller regelmæssigt placeringen at evt. beskyttelse fødder / filt puder er korrekt placeret for bedste beskyttelse af gulvene.