

# ASSEMBLY INSTRUCTION

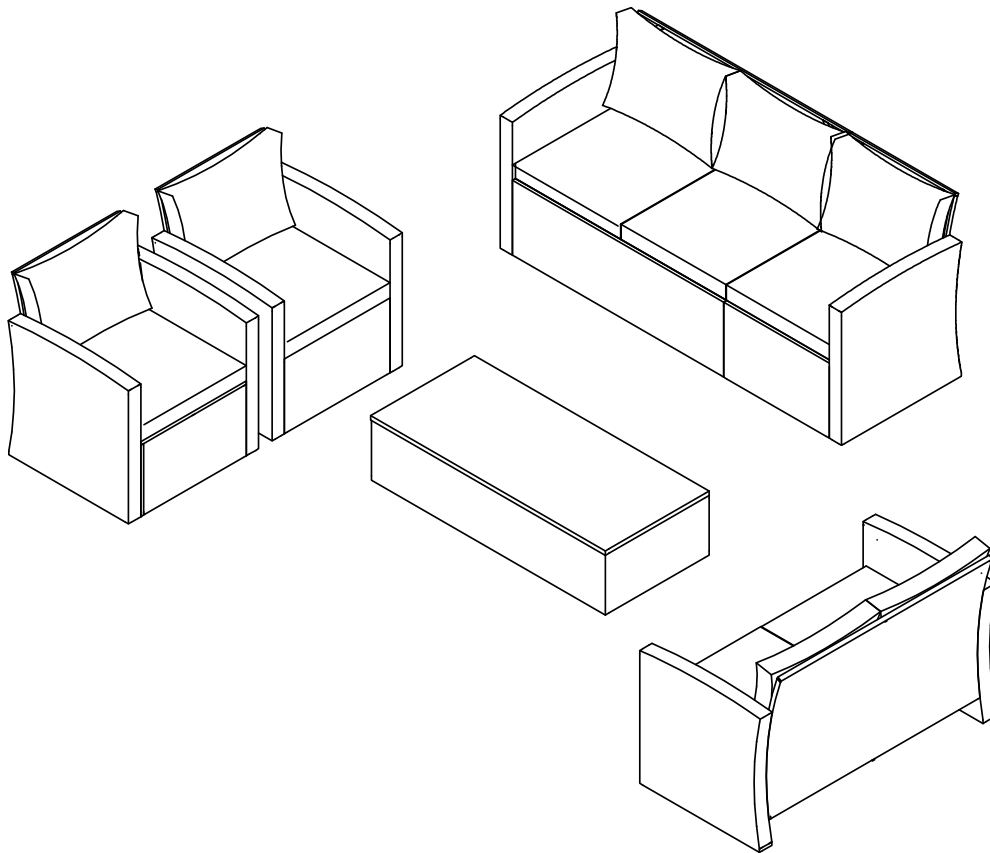





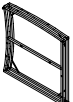
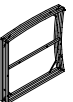

## Important Safety Instructions:

- Please read all instructions before beginning assembly
- Please make sure receive all the parcels to start the assembly
- For your safety and convenience, assembly by two people is recommended
- Use the parts and hardware lists to identify and separate each of the components included
- Save all packing materials until assembly is completed to avoid the accidental discarding of smaller parts or hardware
- In order to compress the package, all cushions are packing in the gap of some parts. So there may be crinkle on the fabric, Don't worry. Just flap every corner of the cushion evenly and it will get back into its original shape
- Do not tighten any screw's fully first until all parts are installed. This may cause the frame to warp. If there is still wobbles or screw holes cannot be aligned loosen the screws and tighten sequentially.

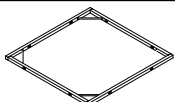
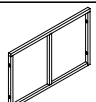

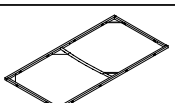
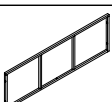
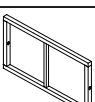
THANK YOU FOR PURCHASING

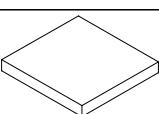
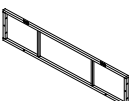
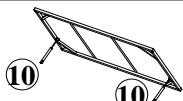
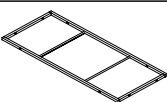
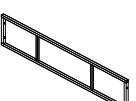
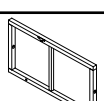
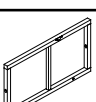
## PARTS LIST

<b>A</b>	LEFT ARMREST	4PCS	
<b>B</b>	RIGHT ARMREST	4PCS	
<b>C</b>	CHAIR BACKREST	3PCS	
<b>D</b>	CHAIR SEAT PANEL	3PCS	
<b>E</b>	CHAIR FRONT PANEL	3PCS	
<b>F</b>	LOVESEAT BACKREST	2PCS	
<b>G</b>	LOVESEAT SEAT PANEL	2PCS	
<b>H</b>	LOVESEAT FRONT PANEL	2PCS	
<b>I</b>	SUPPORT PANEL	1PC	
<b>L</b>	BACK CUSHION	7PCS	
<b>M</b>	SEAT CUSHION	7PCS	
<b>N</b>	TABLE BACK PANEL	1PC	
<b>O</b>	TABLE TOP PANEL	1PC	
<b>P</b>	TABLE BASE	1PC	
<b>Q</b>	TABLE FRONT PANEL	1PC	
<b>R</b>	TABLE SIDE LEFT	1PC	
<b>S</b>	TABLE SIDE RIGHT	1PC	
<b>T</b>	TABLE INNER LINER	1PC	

# HARDWARE

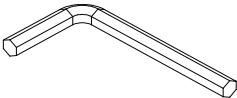
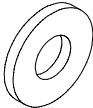
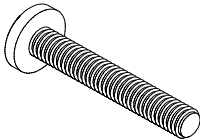
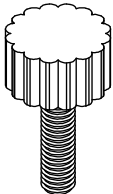
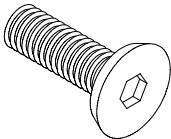
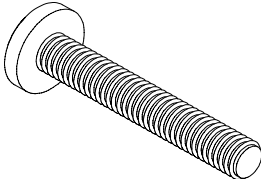
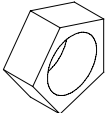
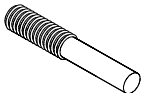
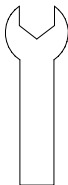
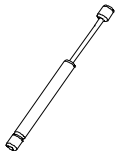
			
<b>1</b> Allen Key - x2	<b>2</b> Washer M6 - x104 + 4	<b>3</b> Bolt M6x35- x96 + 4	
			
<b>4</b> Feet M6x20 - x24+2	<b>5</b> Bolt M6x15 - x4	<b>6</b> Bolt M6x55- x6 + 1	
			 Installed on table top
<b>7</b> Nut - x6+1	<b>8</b> Steel Cottar - x1	<b>9</b> Wrench - x1	<b>10</b> Gas spring - x2

Please don't fasten the screw completely during assembly process. It will be likely to lead to an assembling problem that screw hole position is not aligned. You can fasten completely when all parts have been assembled.

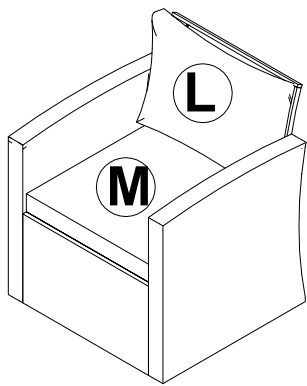

Single Chair x2

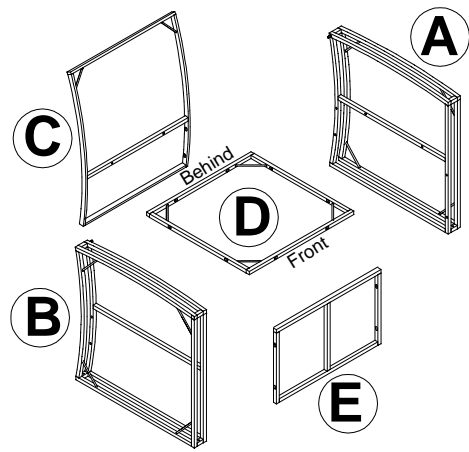

Note : Do not tighten bolts until all parts are connected

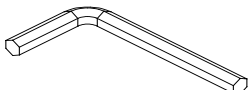

Allen Wrench - 1pcs

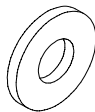

Washer - 32pcs

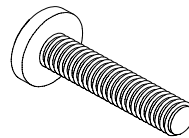

Bolt (M6\*35mm) - x32pcs

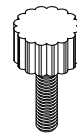

Foot leveler - 8pcs

**Step 1:**

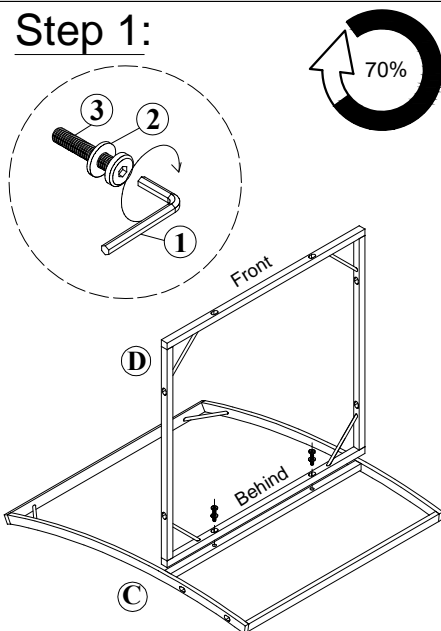

**Step 2:**

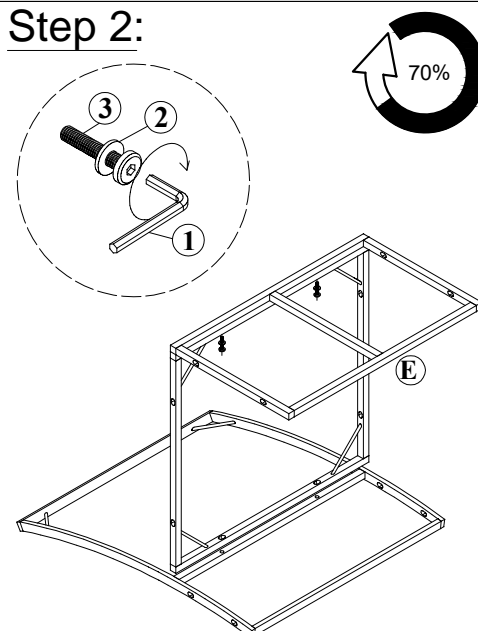

**Step 3:**

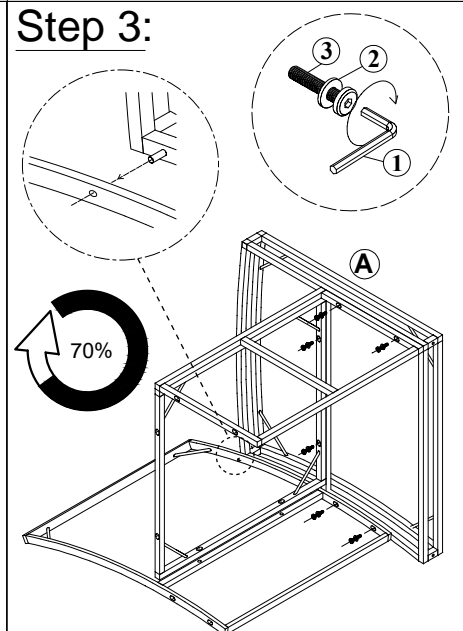

**Step 4:**

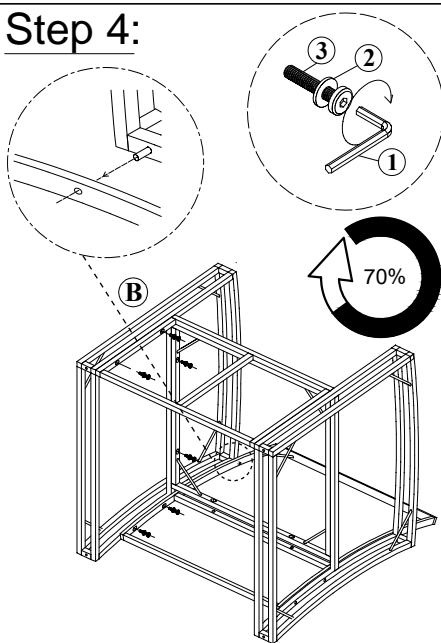

**Step 5:**

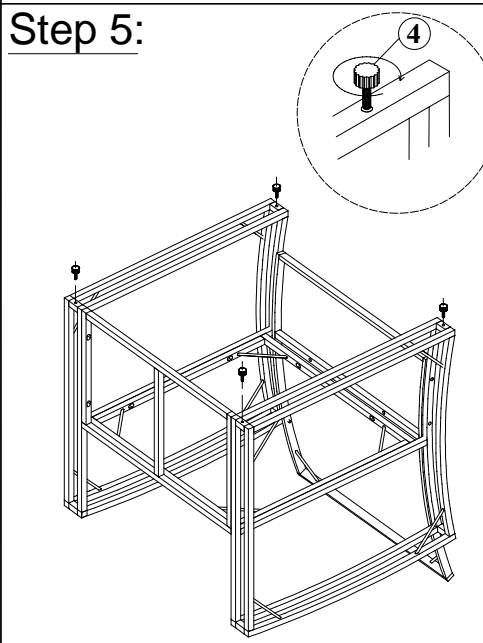

**Finish :**

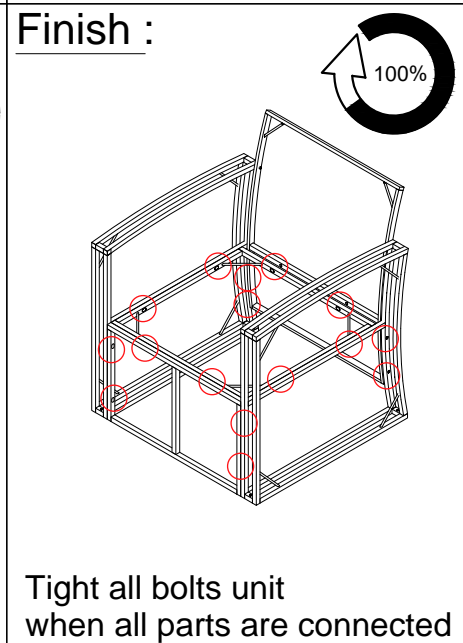

Tight all bolts unit when all parts are connected

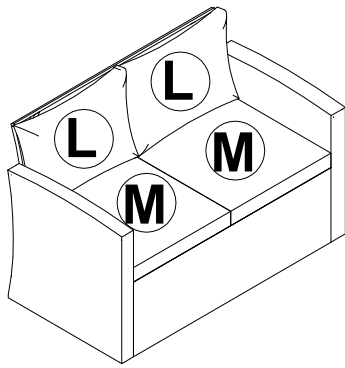

Love Seat x1

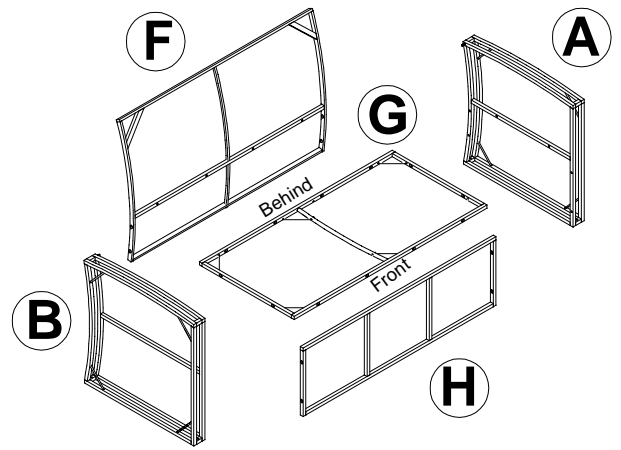

Note : Do not tighten bolts until all parts are connected

 <p>Allen Wrench - 1pcs</p>	 <p>Washer - 20pcs</p>	 <p>Bolt (M6*35mm) - x20pcs</p>	 <p>Foot leveler - 5pcs</p>
--	---	---	--

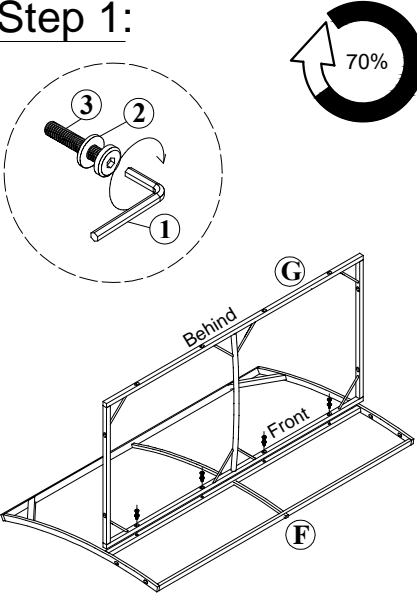
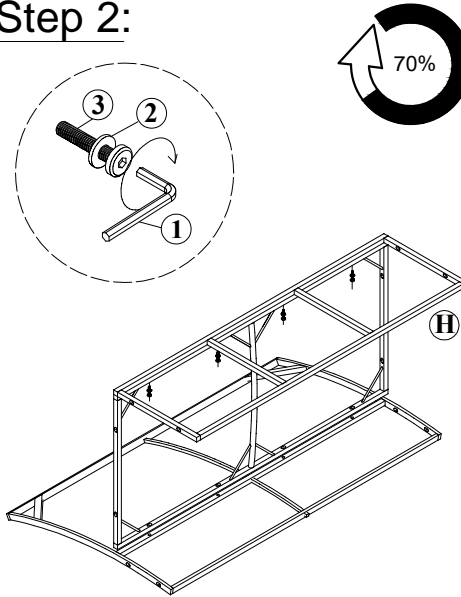
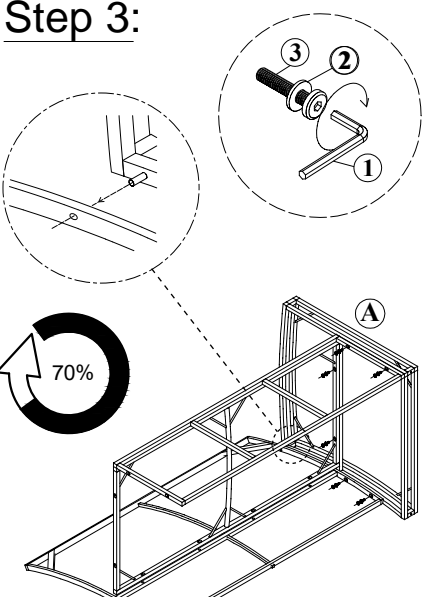
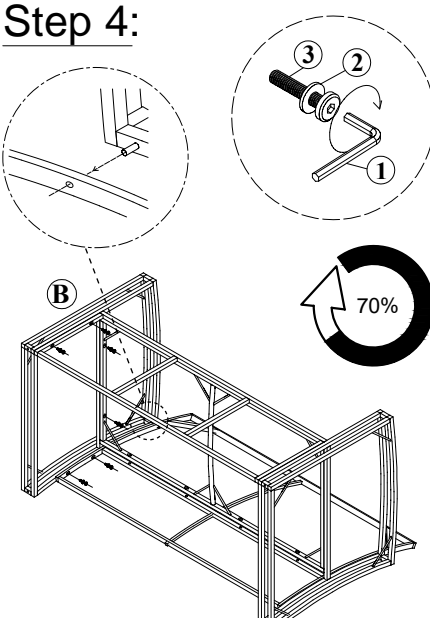
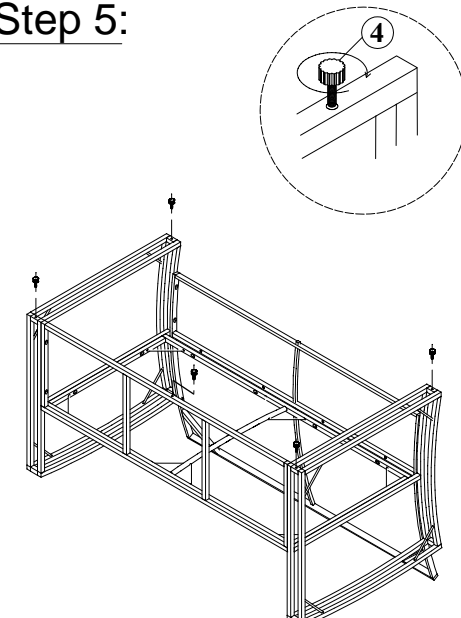
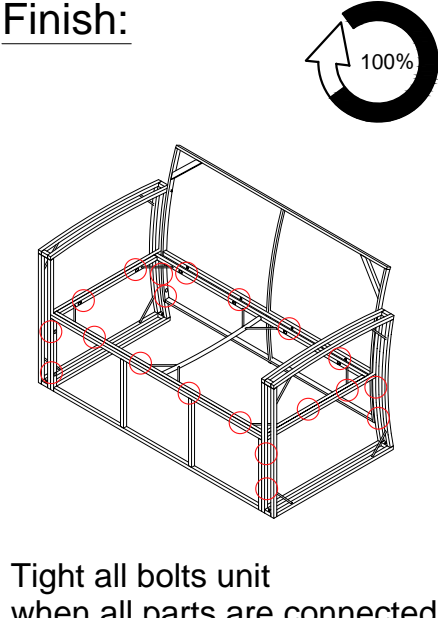

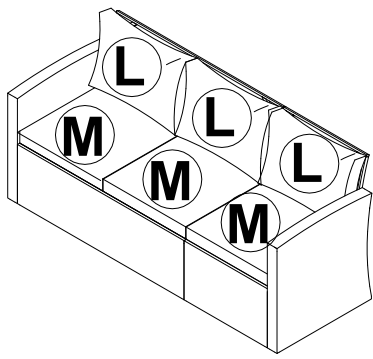

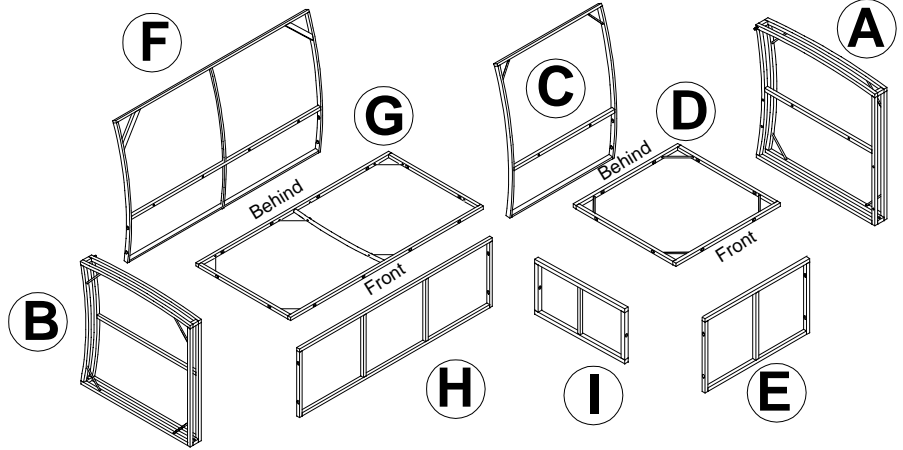

<p><b>Step 1:</b></p> 	<p><b>Step 2:</b></p> 	<p><b>Step 3:</b></p> 
<p><b>Step 4:</b></p> 	<p><b>Step 5:</b></p> 	<p><b>Finish:</b></p>  <p>Tight all bolts unit when all parts are connected</p>

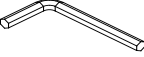

Bench 3x1

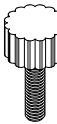
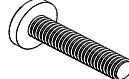

Note : Do not tighten bolts until all parts are connected

							
Allen Wrench - 1pcs	Washer - 40pcs	Bolt (M6*35mm) - 28pcs	Foot leveler - 7pcs	Bolt (M6*55mm) - 6pcs	Nut - 6pcs	Steel Cottar - x1	Wrench - x1

Step 1:

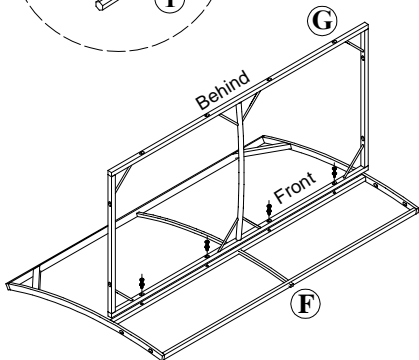
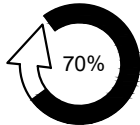
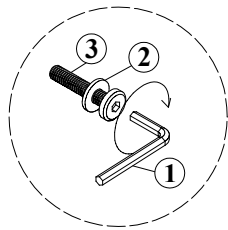

Step 2:

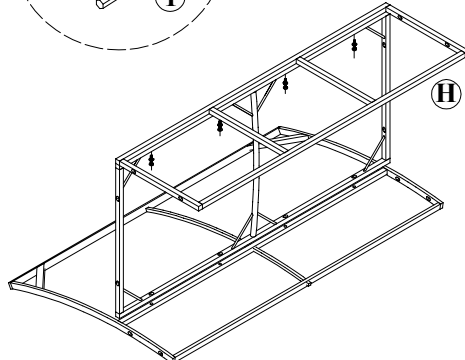
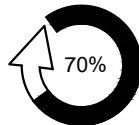
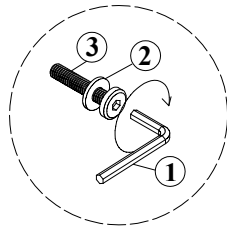

Step 3:

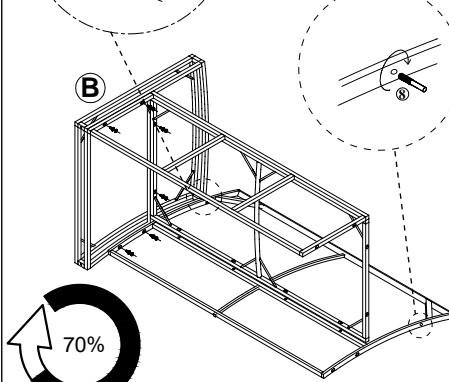
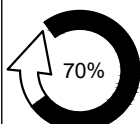
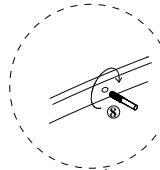
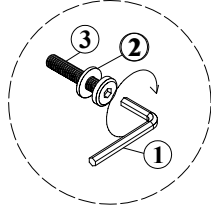
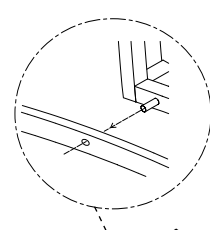

Step 4:

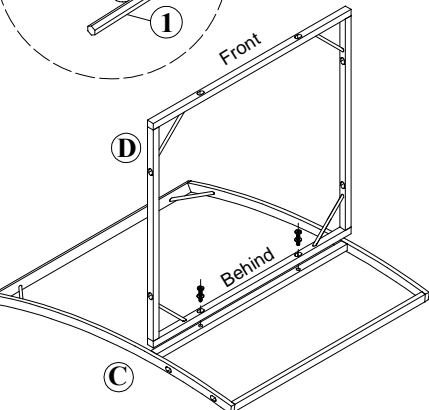
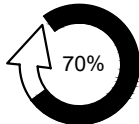
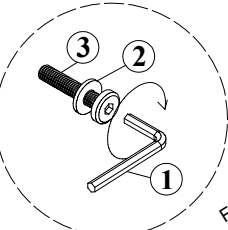

Step 5:

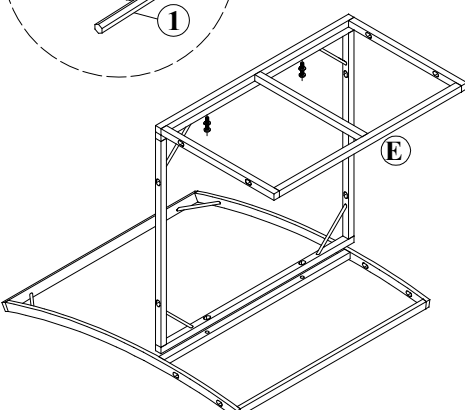
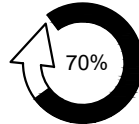
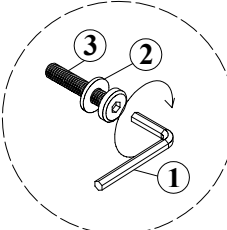

Step 6:

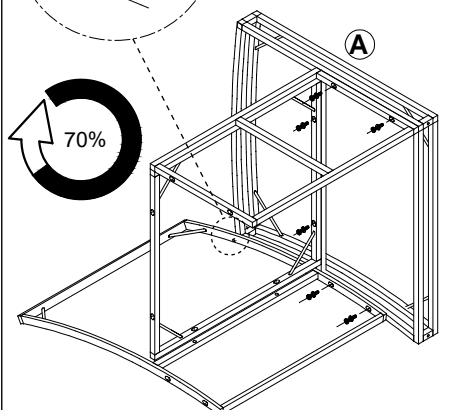
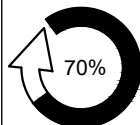
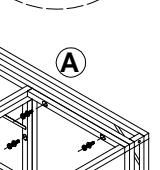
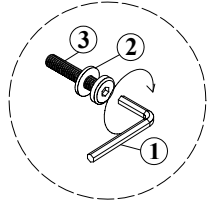
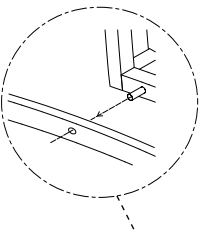

### Step 7:

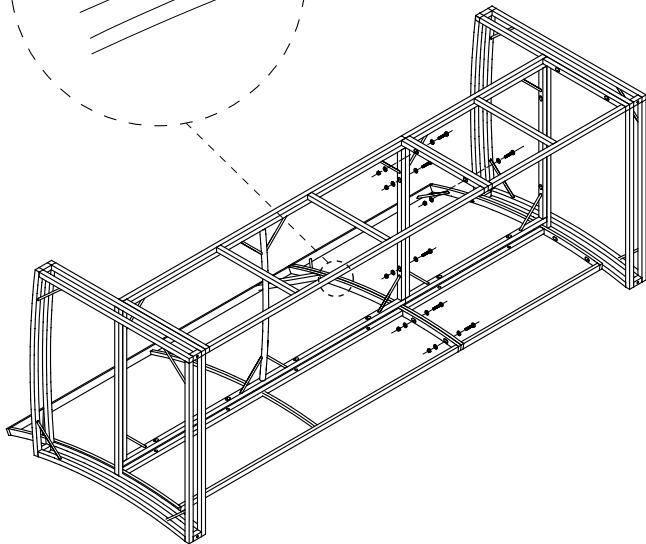
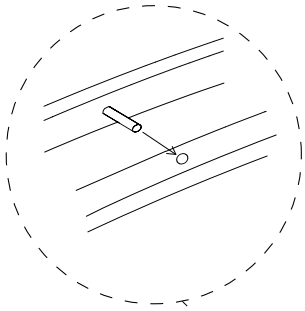
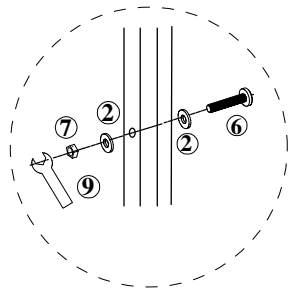
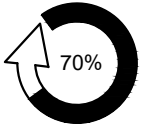

### Step 8:

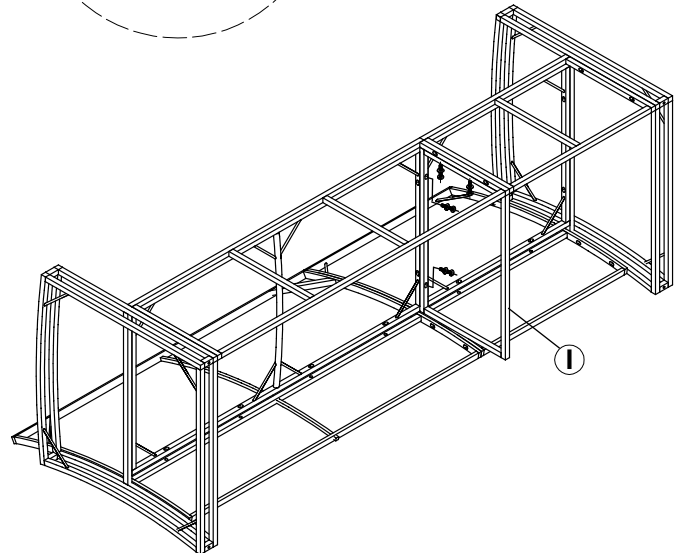
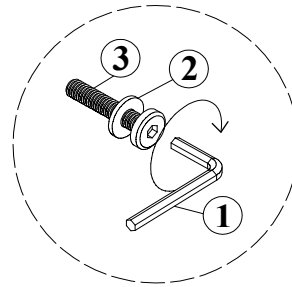
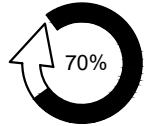

### Step 9:

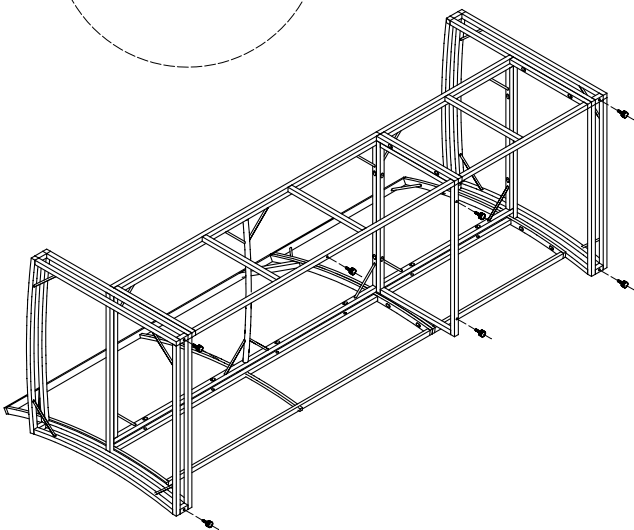
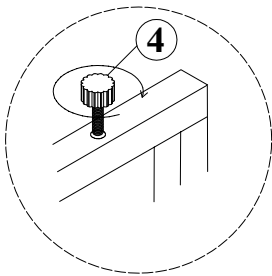

### Finish:

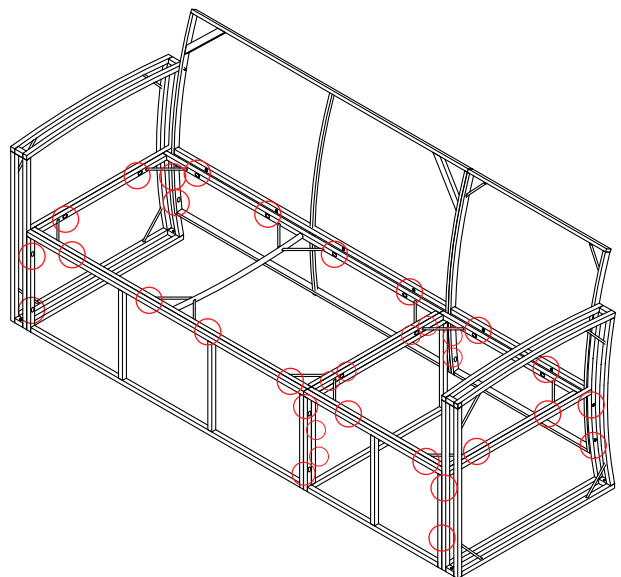
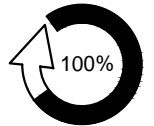

Tight all bolts unit  
when all parts are connected

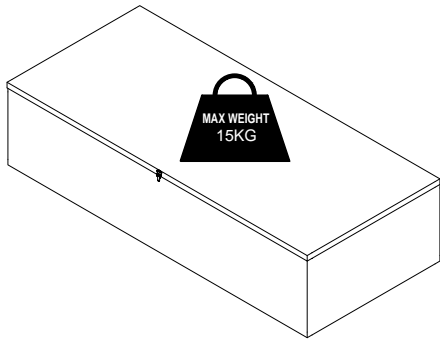
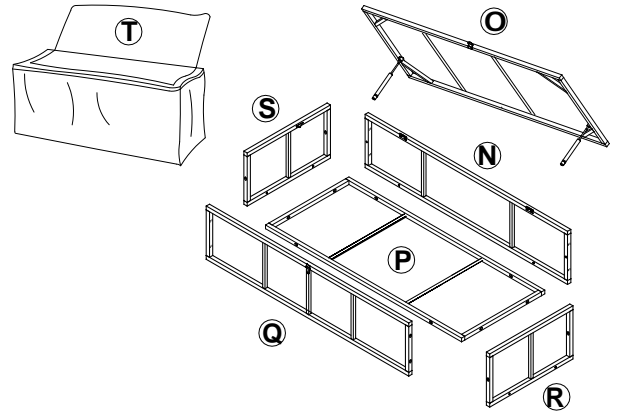
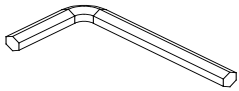
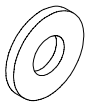
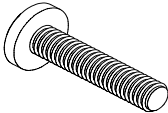
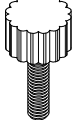
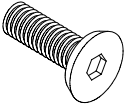

Table x1



**Note : Do not tighten bolts until all parts are connected**

 <p>Allen Wrench - 1pcs</p>	 <p>Washer - 12pcs</p>	 <p>Bolt (M6*35mm) - 16pcs</p>	 <p>Foot leveler - 4pcs</p>	 <p>Bolt (M6*15mm) - 4pcs</p>
--	---	---	--	--

**Step 1:**

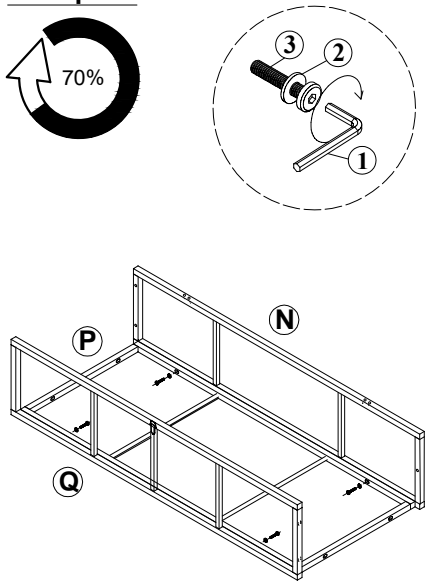

**Step 2:**

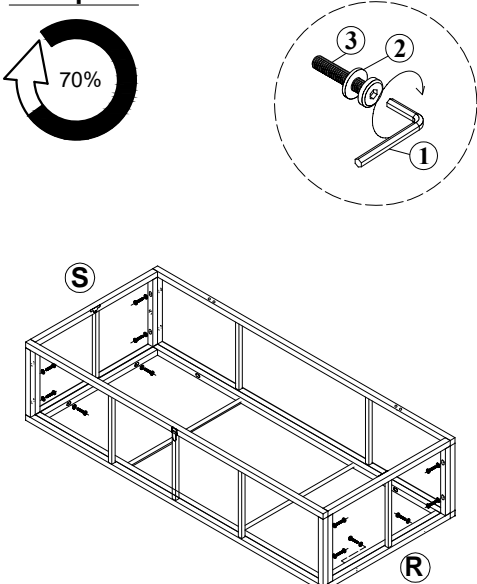

**Step 3:**

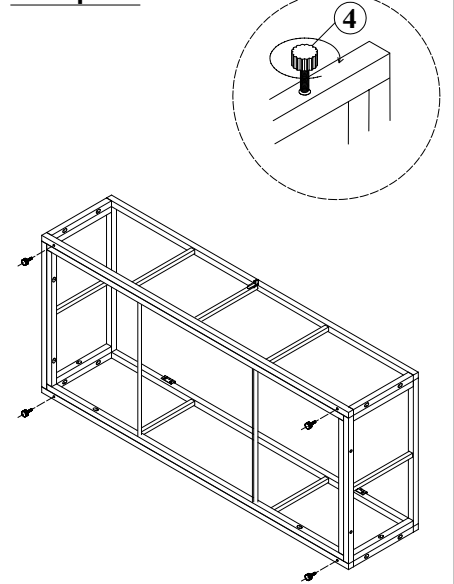

**Step 4:**

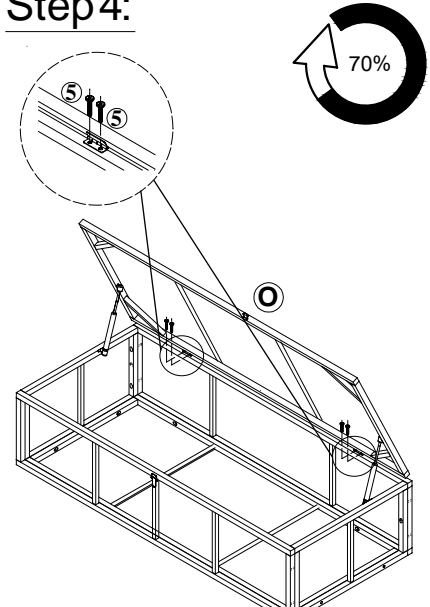

**Step 5:**

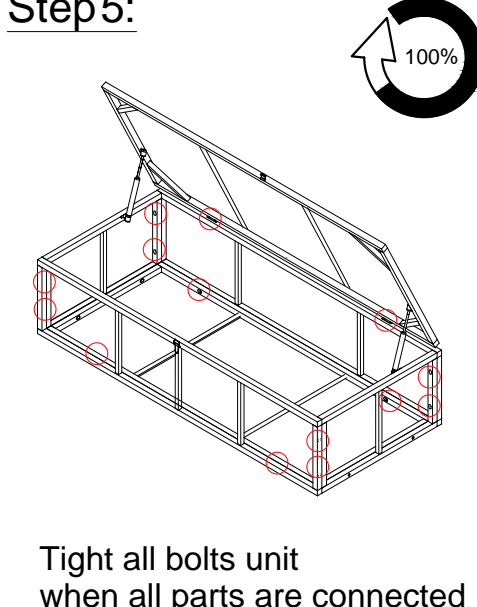

Tight all bolts unit when all parts are connected

**Finish:**

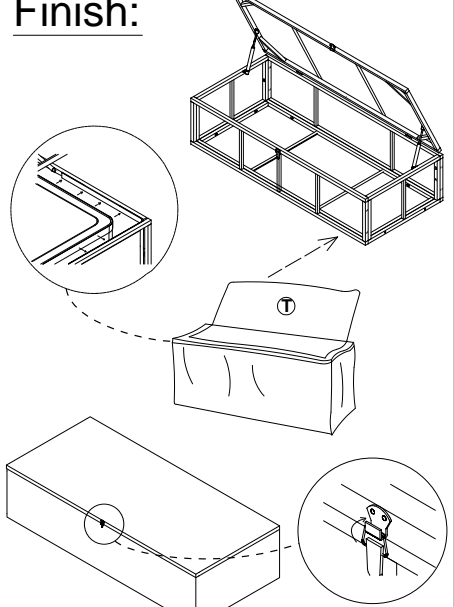

---

## Furniture Care & Cleaning Instruction

- Do not expose the furniture to strong sunlight, which causes discoloration and shortens the product lifetime.
- Do not expose the furniture to extreme heat, cold, or humidity, which may cause wood to swell or warp.
- Do not leave the furniture wet with beads of water standing on the furniture.
- Wipe-spills with a clean dry cloth. Do not use chemicals or abrasives for cleaning!
- TAKE NOTE: THE BOLTS MAY SLIGHTLY LOOSEN OVER TIME. IF YOUR FURNITURE FEELS "WOBBLY" OR LOOSE, PLEASE RE-TIGHTEN BOLTS.

## Wood Furniture Care & Cleaning Instruction

- To maintain the quality of your wood furniture, do not expose it to direct sunlight or excessive temperatures, extreme changes in humidity can cause warping.
- Better use coasters, pads, cloth or felt to protect the furniture surface. Use protective mats under hot dishes. Use a protective pad when writing with a pen.
- Lift objects rather than dragging them over the furniture surface.
- Blot spills immediately with a clean cloth. Dust often using a soft, clean, lint-free cloth. Avoid harsh fabrics, paper towels or disposable dusting towels as they may scratch the surface.
- Use a non-silicone and non-wax polish, do not use soap, water or wax.

## Outdoor Furniture Cushions

Extend the life of your cushions by keeping them free of dirt and foliage. Periodically shaking or rinsing the cushions is recommended. Thoroughly flush using a hose with cold water to remove all soil and residue. For deeper cleaning, spot clean with mild soap. Do not machine wash or use chlorine bleach. Stand cushions on end and dry completely in the sun before using or storing. Do not place in dryer. To prevent mildew, never wrap in plastic for storage and ensure the cushion is completely dry before storing. Store indoors when not in use for long periods of time or during inclement weather.

## Furniture Warranty

### CUSHION AND WOOD COMPONENT

Limited 90 days warranty from date of delivery against manufacturer defects or excessive deformity of cushions and components under normal use and conditions. Replacements and repairs will be in the original color and style, if available; a similar color and style will be offered if the original has been discontinued.

## Important Limitations

- Please note that our warranties do not cover failure due to:
    1. Any modifications to the original structure of the product/Accidental damage/Abuse/Misuse/Commercial Use.
    2. The wear and tear caused by daily use, including: fading, scratching or chipping.
  - Any defects Parts or missing parts must be reported within the 30 days of receipt of the item otherwise it would be out of our 90 days warranty term.
- 
-