

STEP 6

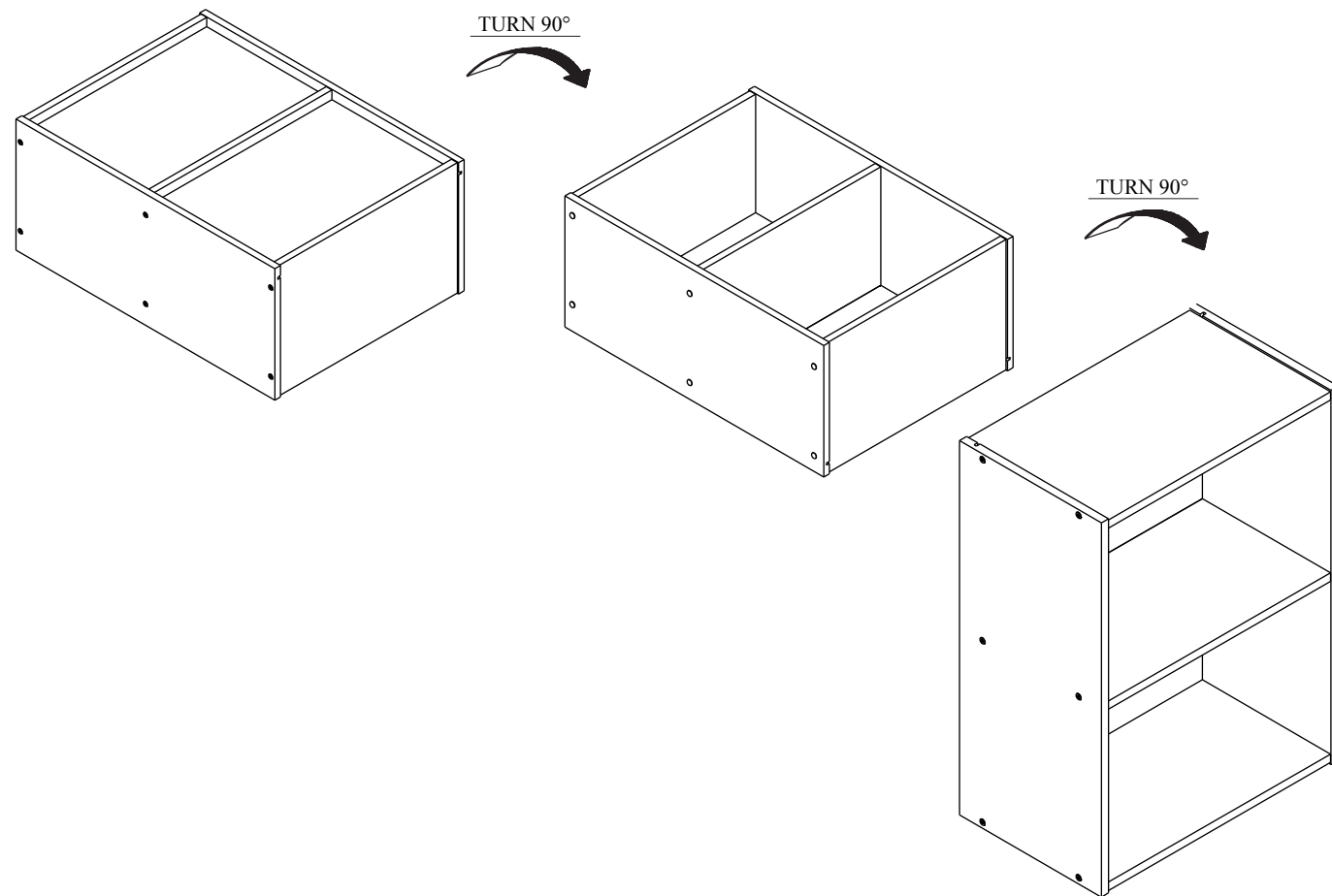

Recommended Maximum Weight

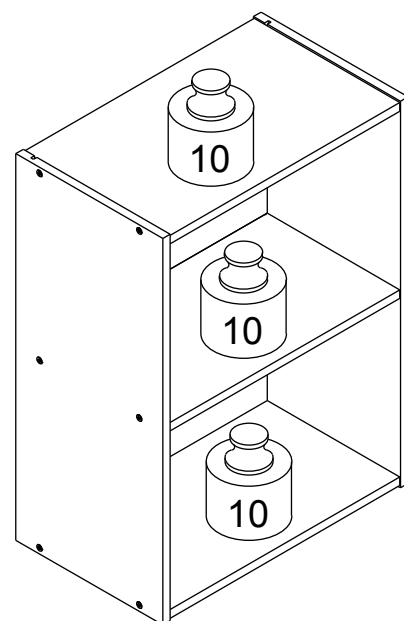

*Unit in Pound(lbs.)

WARNING:

>This unit has been designed to support the maximum loads shown. Exceeding these load limits could cause sagging, instability, product collapse, and/or serious injury.

>DO NOT allow children to climb on unit.

> Put heavier items on lower shelves.



00:15

Approx. 15 minutes



Recomm. 1 Person

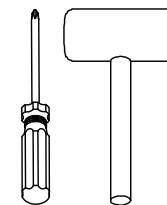

Tools Required

Assembly Instruction

Furinno Luder 2-Tier Open Shelf Bookcase

MODEL : 21049

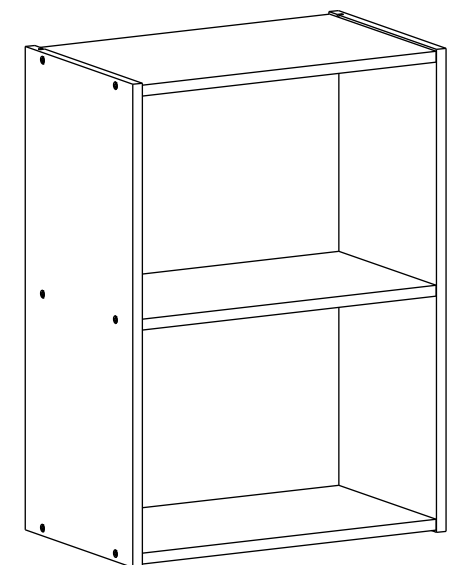





Customer Support

NEED HELP? For replacement requests or product inquiries, please contact our Customer Service Team by emailing us at support@furinno.com. Thank you for selecting Furinno!

www.furinno.com



HARDWARE & PARTS LIST

NO	HARDWARE LIST	QTY
1	CHIPBOARD SCREW 	12pcs
2	DOWEL 	12pcs
3	L BRACKET 	4pcs
4	SCREW 	8pcs
5	STICKER 	12pcs

NO	PARTS LIST	QTY
A	L/R SIDE PANEL	2pcs
B	TOP/BOTTOM PANEL	2pcs
C	SHELF PANEL	1pc
D	BACK PANEL	2pcs

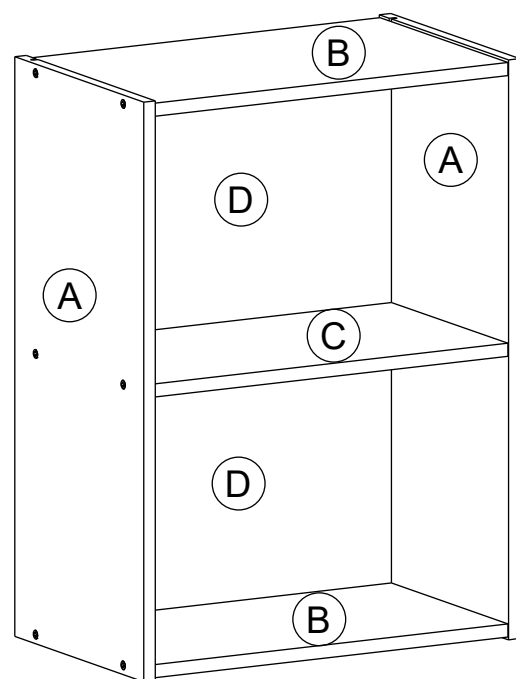

USEFUL HINTS BEFORE YOU START:

1. Read each step carefully before starting.
2. It is important that each step is performed in correct order to avoid difficulties.
3. Identify, sort and count the parts before assembly.
4. Assemble your furniture on packaging cardboard to prevent scratch or damage.
5. Clean the product with mild cleanser using soft damped cloth. Do not use harsh or abrasive cleanser.
6. Using incompatible hardware might cause damage to product.

ASSEMBLY INSTRUCTIONS

BEFORE YOU BEGIN, PLEASE READ ASSEMBLY INSTRUCTIONS CAREFULLY, FOLLOW THEM STEP BY STEP.

STEP 1

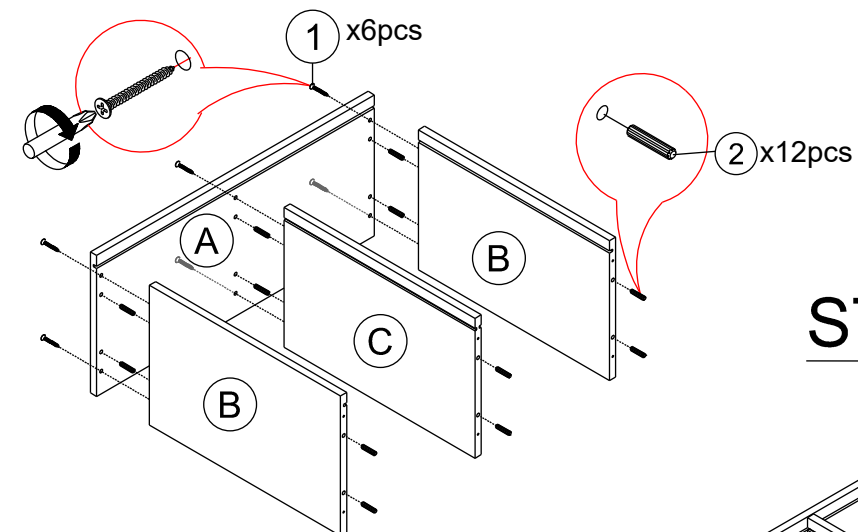

STEP 2

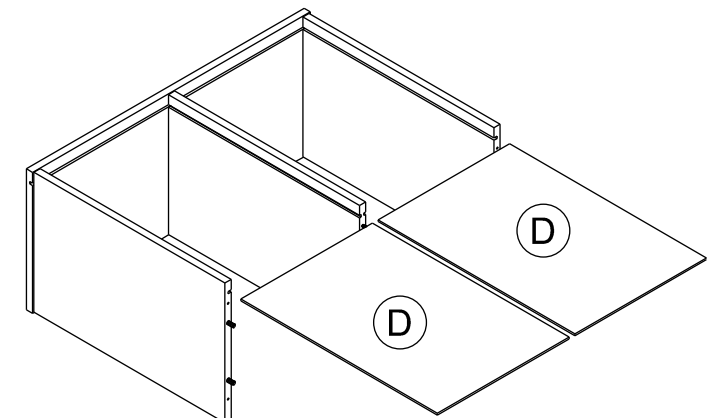

STEP 3

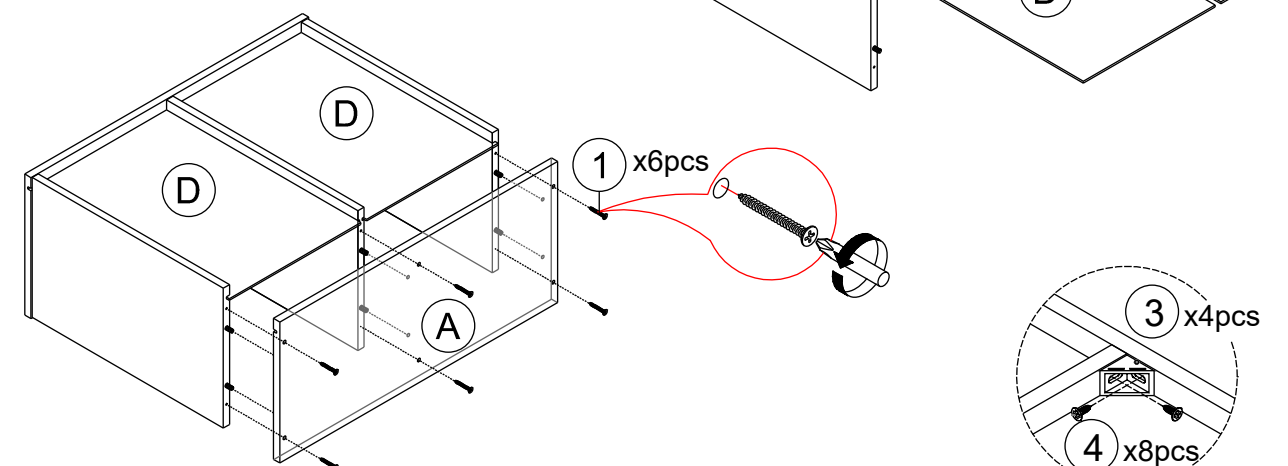

STEP 4

