

# ASSEMBLY INSTRUCTIONS

## DINING TABLE

ASSEMBLY  
REQUIREMENTS

30 MINUTES  
Assembly Time  
Approximate

2-Person  
Assembly

Tools Required  
(Not Provided)



### Thank you for purchasing our product!

Please refer and use this assembly instruction to assemble the product. Contact our customer service department in case there are any missing or damage parts or hardware. Replacement parts are normally shipped within 2 or 3 days.

**PRODUCT PURCHASED THROUGH OUR AUTHORIZED VENDORS ONLY ARE ELIGIBLE FOR REPLACEMENT PARTS**

**We appreciate your business!**

**THIS PRODUCT IS FOR INDOOR AND HOUSEHOLD USE ONLY- NOT FOR COMMERCIAL USE.**

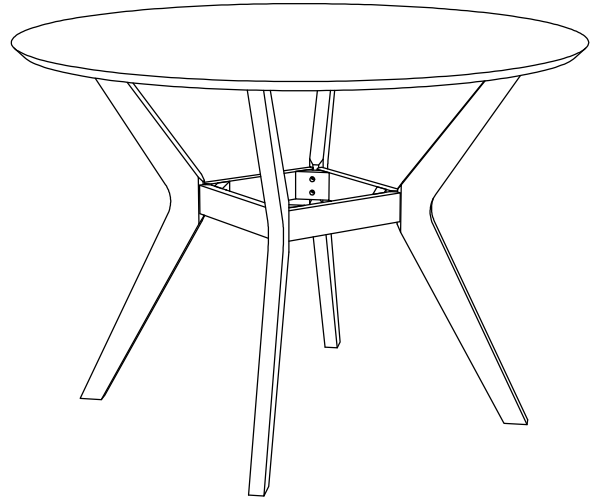

### ASSEMBLY PREPARATION

1. Remove all packaging materials, staples and packing straps from the carton.
2. Refer to Parts List and Hardware List and ensure parts and hardware are correct before assembly. Contact customer service for missing parts.
3. Place all wooden parts on a clean, flat and soft surface (e.g. carpet or rug) to prevent parts from getting scratched.

### SAFETY PRECAUTION

1. KEEP ALL HARDWARE PARTS OUT OF REACH OF CHILDREN.
2. DISPOSE PLASTIC PACKAGING MATERIAL IMMEDIATELY TO AVOID ANY RISK OF SUFFOCATION TO CHILDREN AND ANIMALS.

### TIPS FOR ASSEMBLY

1. Allow ample room for assembly and in close proximity to where product will be placed.
2. Assemble the product on a surface that does not scratch or damage the exterior gloss and finish of the furniture.
3. Identify all of the parts, hardware and quantities required for each step.
4. During assembly, do not over-tighten any fittings as this may cause damage.
5. DO NOT USE POWER TOOLS TO ASSEMBLE THIS PRODUCT.
6. Always place the product on a flat, level surface.
7. Do not sit or stand on the partially assembled product; only use the product for which it is intended.

### CARE AND MAINTENANCE

- Wipe clean with a soft , dry cloth; avoid the use of harsh chemicals or household cleaners as they may damage the exterior finish of the furniture.
- Hardware may loosen over time. Periodically , check that all connections are tight ; re-tighten as necessary.
- Solid wood is impacted by heat and humidity fluctuations which may cause in small joint separations or hairline cracks; place the furniture away from direct sunlight and air conditioning vents, heating vents or units to protect the furniture.

# ASSEMBLY INSTRUCTIONS

## DINING TABLE

### PARTS LIST (FOR 1 COMPLETE TABLE)

NO.	DESCRIPTION	QTY
P1	TABLE TOP	1
P2	TABLE LEG	4
P3	STRETCHER	1
P4	CROSS BAR	2

### HARDWARE LIST (FOR 1 COMPLETE TABLE)

NO.	DESCRIPTION	QTY	EXTRA
H1	ALLEN KEY M4 x 65mm 	1	
H2	JCBC SCREW M6 x 40mm 	4	1
H3	SPRING WASHER M6x13mm 	4	1
H4	FLAT WASHER 1/4 x 19mm 	4	1
H5	ALLEN KEY M5 x 65mm 	1	
H6	JCBB SCREW M8 x 70mm 	8	2
H7	SPRING WASHER 5/16 	8	2
H8	FLAT WASHER 5/16 x 22mm 	8	2
H9	LEG STUD M6 x 24mm 	4	1
H10	WOOD SCREW M4 x 30mm 	17	2

## STEP 1

- With assistance, place each Table Leg (2) against each corner of Stretcher (3) and align the screw holes on the respective parts.
- Insert JCBB Screw (H6) fitted with Spring Washer (H7) and Flat Washer (H8) through the screw hole on the corner block into the screw hole on (P2). Use Allen Key (H5) to drive (H6) into (P2). Do not tighten (H6) completely until both screws are in place on each leg.

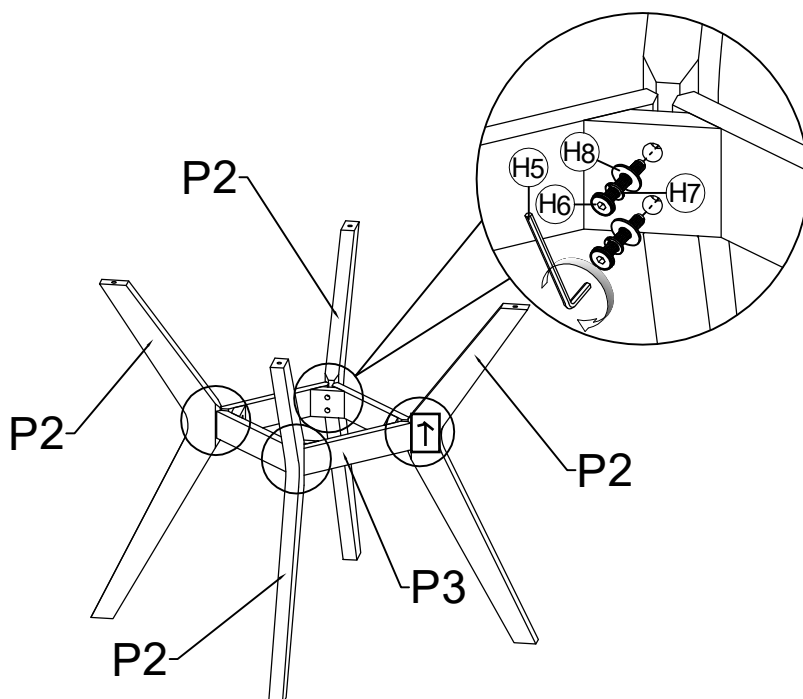

## STEP 2

- Position Cross Bar (P4) diagonally across Table Legs as shown.
- Insert JCBC Screw (H2) fitted with Spring Washer (H3) and Flat Washer (H4) through the elongated screw hole on (P4) into the screw hole on top edge of Table Leg. Use Allen Key (H1) to drive (H2) into (P4) and tighten (H2) completely.

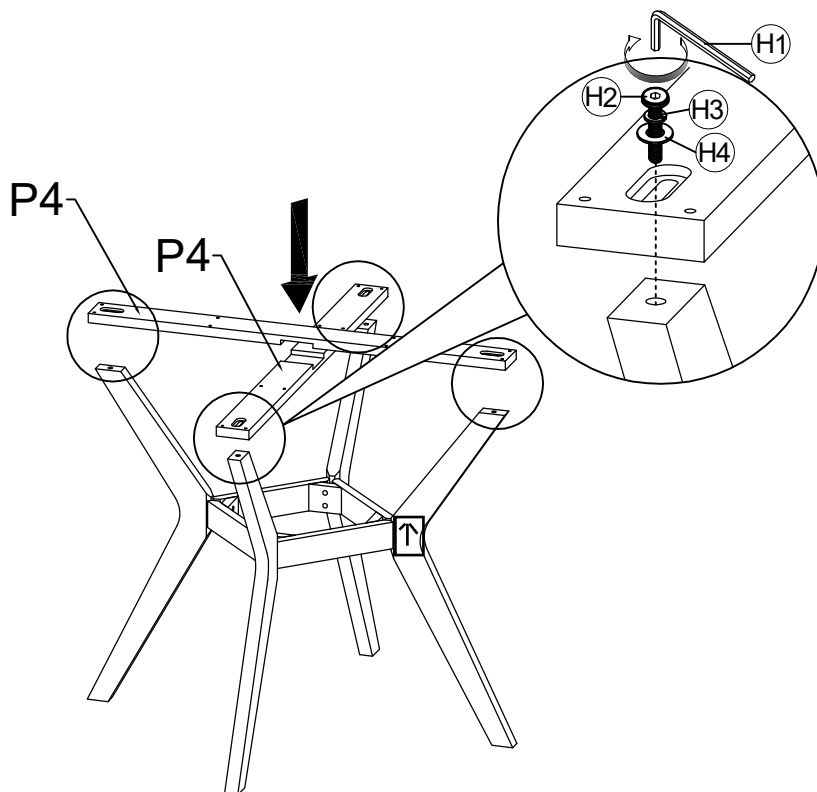

# ASSEMBLY INSTRUCTIONS

## DINING TABLE

### STEP 3

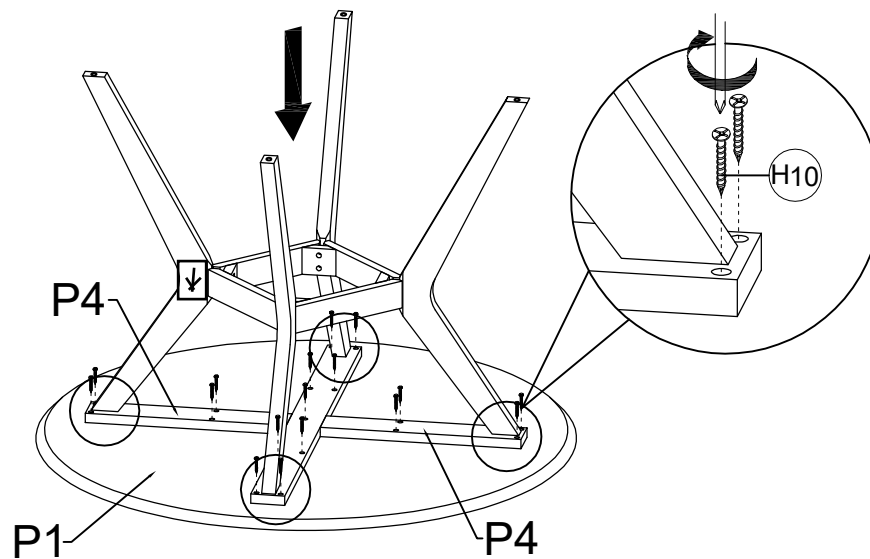

- With assistance, lay Table Top (P1) bottom-side up flat on a soft surface to prevent scratch and damage.
- Position leg assembly from STEP 2 to align to the markings on the bottom-side of (P1) and use Screw (H10) to fasten Table Top to Table Support.

### STEP 4

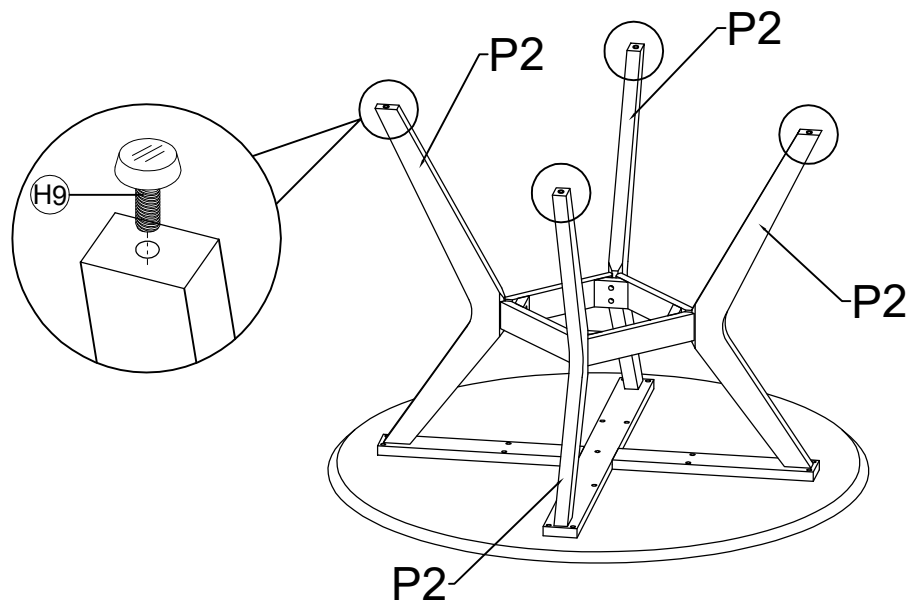

- Screw in threaded Leg Stud (H9) into each of the screw hole on (P2).
- Set the table right-side up and adjust (H9) to level table if necessary.
- The assembly of the table is complete.