

PENDANT

PLEASE READ AND SAVE FOR FUTURE REFERENCE.

CAUTION

1. Turn off the main power at the circuit breaker before installing the fixture in order to prevent possible shock.
2. All electrical connections must be in accordance with local and National Electrical Code (N.E.C.) standards. If you are unfamiliar with proper electrical wiring connections, obtain the services of a qualified electrician.
3. **WARNING:** The outlet box must be capable of supporting at least 25 lb.

GENERAL

Remove all parts and hardware from the box and make sure that none are missing by referencing the illustrations provided.

Bulbs Required (not included): 2 Medium Base 100 Watt Max. (for 2-Light Pulley Pendant)

3 Medium Base 100 Watt Max. (for 3-Light Pulley Pendant)

2-LIGHT PULLEY PENDANT 3-LIGHT PULLEY PENDANT

1. OUTLET BOX (not included)
2. MOUNTING PLATE
3. OUTLET BOX SCREWS and WASHERS
(pre-attached to outlet box)
4. BLACK SUPPLY WIRE (not included)
5. SMOOTH (or BLACK) FIXTURE LEAD WIRE
6. WHITE SUPPLY WIRE (not included)
7. RIBBED (or WHITE) FIXTURE LEAD WIRE
8. FIXTURE GROUND WIRE
9. SUPPLY GROUND WIRE (not included)
10. WIRE CONNECTORS
11. ANCHOR SCREWS
12. FIXTURE SCREWS and HEX NUTS
13. ANCHORS
14. GROUND SCREW (pre-attached)
15. CANOPY
16. DECORATIVE NUTS (pre-attached)
17. CORD RESTRAINTS (pre-attached)
18. CORDS (pre-attached)
19. PULLEY WHEELS (pre-attached)
20. FIXTURE
21. SOCKETS (pre-attached)
22. SOCKET RINGS (pre-attached)
23. SWITCHES (pre-attached)
24. SHADES
25. PULLEY WEIGHTS (pre-attached)

IMPORTANT: If you wish to change cord length, loosen cord restraint located on the canopy with a flathead screwdriver (not included). Adjust cord to desired length by pulling cord up through canopy, tie a knot in the cord and re-tighten cord restraint.

CAUTION: Do NOT overtighten cord restraint.

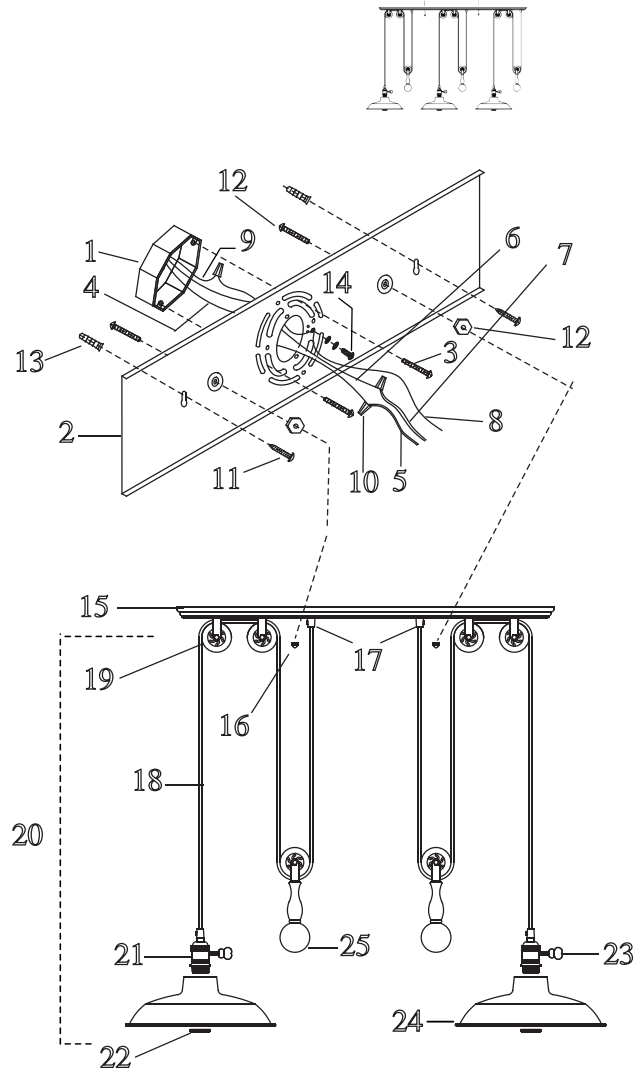

CARE & CLEANING: Initial care for finishes requires periodic cleaning with a soft cloth, dampened with water. A mild non-abrasive soap may be used along with a soft cloth and water if the fixture is very dirty. Particular care should be taken to avoid abrasive materials and strong cleaning agents as they will quickly destroy the protective coatings and subject the finish to oxidation and discoloration.